

On the Border:

an architectural inquiry into the sacred and quotidian

by
Michael Nicholas-Schmidt

A thesis
presented to the University of Waterloo
in fulfillment of the
thesis requirement for the degree of
Master of Architecture

Waterloo, Ontario, Canada, 2009
© Michael Nicholas-Schmidt 2009

AUTHOR'S DECLARATION

I hereby declare that I am the sole author of this thesis. This is a true copy of the thesis, including any required final revisions, as accepted by my examiners.

I understand that my thesis may be made electronically available to the public.

ABSTRACT

Even in our secular age, the sacred continues to be a powerful cognitive space in the landscape of the imagination. I am a Roman Catholic and amongst those who struggle to exist both in the structured universe of the sacred, and the contemporary plurality of the city.

The mystery of the incarnation provides a theological argument for the indwelling of the Spirit in creation through time. With the advent of secularism however, it is possible to conceive of a time outside the sacred. Tension within theology in academia, faith in politics, or religion in a pluralistic society, reveals a boundary between our beliefs and our public face which becomes a rigid barrier – distinct as the private and public. Conflicting temporal structures of the sacred and secular give definition to this divide.

Architecture has historically placed itself as interlocutor, negotiating complex thresholds in order to engage meaning. Contemporary sacred architecture, however, has avoided confrontation with the public realm. Thick edges distinguish the realms of the sacred and the quotidian. This thesis engages the border between the sacred and the secular.

An analysis of the temporal structures of contemporary sacred space and its civic environment opens up an exploration of one such border around St. Basil's Church in Toronto. The definition of a threshold at this edge challenges our contemporary divide by exploring potential transitions. Between the church and the street, architecture inhabits the edge, expanding and articulating connections. Methods are explored for constructing built forms which promote a transition between, and interaction of, sacred and secular temporalities. At this threshold, individual creativity provides metaphors for ontology. Crossing this threshold creates opportunities for overlap between the time of the sacred and the time of the secular. These transitions challenge how we imagine both the church and the city in contemporary architecture.

ACKNOWLEDGEMENTS

Supervisor: Anne Bordeleau

Advisors: Robert Jan Van Pelt, and Philip Beesely

External Examiner: Roberto Chiotti

Many have helped mould this thesis and through their work have helped me grow. A very special thanks to Anne Bordeleau whose encouragement, patience, and wisdom has guided this thesis. From a disorganized collection of intuitions, you have helped me explore both my beliefs and my ideas, and this has forever changed me.

Robert Jan, and Philip, thank you for your insightful contributions and limitless stream of suggestions. You helped me reach beyond my expectations and pushed me to appreciate the complexities of the sacred.

To a friend and mentor, John Bentley-Mays, you have helped me more than you will ever realize. Our occasional coffee's kept this thesis going, and fueled my ongoing passion for asking difficult questions. Your thoughts and prayers have been much appreciated.

To the many who agreed to give their time to hear my thoughts and share their expertise: Fr. Dan Donovan, Fr. Paul McGill, Fr. Jim Link, Pastor Michael Mills, Nicholas Choy, Paul Blaser, and Roberto Chiotti. Thanks to Evelyn Collins at the St. Michael's Archives.

To Justin Perdue, who somehow manages to both challenge and inspire me, our discussions have made this thesis possible.

Finally to my wife Vanessa and family, Bill, Vera, Anne, Joe, Ed, Ashley, Kyle, thank you for your love, patience, and support, which gives life to this work.

This thesis is the product of much thought and prayer. And only when these two come together does it finally begin to take form: always moving between the infinite and finite, design and theory, faith and reason, divine and mortal, earth and sky, in this liminal zone between, architecture takes form.

for my wife, Vanessa

TABLE OF CONTENTS

List of Illustrations - vii
Introduction - 2

PART ONE: The Divine; *the sacred*

| | | | |
|------|----------------------------------------|----|-----------------|
| .i | The Cleansing of the Temple | 12 | |
| .ii | Exegesis | 13 | |
| .iii | Reflection | 15 | |
| .iv | Defining Sacred Space & Time | 16 | St. Basil's |
| .v | Interpreting Sacred Space | 20 | Catholic Church |
| .vi | The Numinous | 26 | |
| .vii | The Edge | 32 | |

PART TWO: The Mortal; *the quotidian*

| | | | |
|------|------------------------------------------|----|------------|
| .i | The Wedding at Cana | 42 | |
| .ii | Exegesis | 43 | |
| .iii | Reflection | 45 | |
| .iv | Defining The Quotidian | 46 | Bay Street |
| .v | The Experience of the Quotidian. | 52 | |
| .vi | Instrumental Space | 62 | |

PART THREE: The Earth; *the eternal in the everyday*

| | | | |
|------|-----------------------------|----|----------------------|
| .i | The Call of Levi | 70 | |
| .ii | Exegesis | 71 | |
| .iii | Reflection | 73 | |
| .iv | The Creative City | 74 | Quotidian Thresholds |
| .v | Thresholds | 79 | |
| .vi | Design | 84 | |

PART FOUR: The Sky; *the material in the divine*

| | | | |
|------|-----------------------------------------|-----|-------------------|
| .i | The Rejection at Nazareth | 96 | |
| .ii | Exegesis | 97 | |
| .iii | Reflection | 99 | |
| .iv | The Material and the Divine | 100 | Sacred Thresholds |
| .v | New Sacred Spaces | 104 | |
| .vi | Towards a Temporality of Thresholds . . | 111 | |

| |
|--------------------------|
| Endnotes - 118 |
| Bibliography - 124 |
| Appendix A: |
| Recent Landmark Catholic |
| Church Projects - 126 |

LIST OF ILLUSTRATIONS

| <i>Figure</i> | Page | Title | | | |
|---------------|--------------|----------------------------------------------------------------------------------------------------------------------------------------------------|--|------|----------------------------------------------------------------------------------------------------------------------------------------------------------------------------------------------|
| | | Source | | | |
| 0.1 | xii | Street Signage along Bay St. (Basilian General Curia) photograph by author. | | 1.5 | 25 |
| 0.2 | 3 | Cross Section across St. Basil's Church & Bay Street illustration by author. base map source: City of Toronto Mapping Services(2002) | | 1.6 | 26,27 |
| 0.3 | 4 | Bay Street Looking North photograph by author. | | 1.7 | 27 |
| 0.4 | 5 | St. Basil's Interior Photograph by Christopher Dew from: Barthos, Gordon <i>The Story of St.Basil's</i> , Toronto (2006) | | 1.8 | 27 |
| 0.5 | 6 | Elevation of Bay Street mixed media by author. | | 1.9 | 29 |
| 0.6 | 9 | Diagram of Divine, Sky, Earth and Mortal illustration by author. | | 1.10 | 29 |
| | | PART 1 | | 1.11 | 30,31 |
| 1.1 | 17 | Sections of St. Basil's Church illustration by author. base map source: City of Toronto Mapping Services (2002) | | 1.12 | 32 |
| 1.2 | 18,19 | Evolution of St. Basil's Church illustration by author. base drawing source retrieved from University of St. Michael's archives | | 1.13 | 33 |
| 1.3 | 21 | Temporal Structure of St. Basil's Church illustration by author. | | 1.14 | 34 |
| 1.4 | 23 | Phenomenological experience over time at St. Basil's Church illustration by author. | | 1.15 | 35 |
| | | | | 1.16 | 36 |
| | | | | | Dynamics of relationship at St. Basil's Church illustration by author. |
| | | | | | Chapel at Holy Rosary Complex, Trahan Architects source: http://trahanarchitects.com/ . Accessed April 2009 |
| | | | | | Chapel of St. Ignatius, Stephen Holl Architects source: "Steven Holl: Chapelle Saint Ignace" In <i>Architecture d'Aujourd'hui</i> , May,1999,n.322 |
| | | | | | Church of Light, Tadao Ando photograph by Liao Yushen. source: http:// figure-ground.com /church_light/ . Accessed April 2009 |
| | | | | | St. Basil's Interior, 1907 photograph retrieved from University of St. Michael's archives |
| | | | | | St. Basil's Interior, 2008 photograph by author. |
| | | | | | St. Basil's Sections illustration by author. base map source: City of Toronto Mapping Services (2002) |
| | | | | | Plan and Photographs of Chapel of St. Ignatius source: "Steven Holl: Chapelle Saint Ignace" In <i>Architecture d'Aujourd'hui</i> , May,1999,n.322 |
| | | | | | St. Basil's Narthex illustration by author. |
| | | | | | Plan and Photographs of Our Lady of the Angels source: Sara Hart "Dynamic Concrete in the 21 st Century" In <i>Architectural Record</i> Oct. 2001, v.189. |
| | | | | | St. Basil's ceiling illustration by author. |
| | | | | | Plan and photographs of Church of the Incarnation source: MarcoPolo "Simple Blessings" In <i>Canadian Architect</i> .June 2001, v.46 n.6. |

| | | | | | |
|--------|-------|--------------------------------------------------------------------------------------------------------------------------------------------------------------------------|--------|-------|--------------------------------------------------------------------------------------------|
| 1.17 | 37 | St. Basil's wall and window illustration by author. | 2.12 | 65 | Components of the Bay Street street face illustration by author. |
| 1.18 | 39 | St. Basil's ramp to lower level illustration by author. | 2.13 | 66,67 | Components of the Bay Street street space illustration by author. |
| PART 2 | | | PART 3 | | |
| 2.1 | 47 | Plan of Bay Street from St. Joseph to St. Mary Street illustration by author. base map source: City of Toronto Mapping Services (2002) | 3.1 | 75 | Rhythm of Bay Street illustration by author. |
| 2.2 | 50,51 | Bay Street over the course of a day photographs by author. | 3.2 | 76,77 | Openings creating moments of encounter illustration by author. |
| 2.3 | 53 | Bay Street sidewalk photograph by author. | 3.3 | 79 | Expanding thresholds illustration by author. |
| 2.4 | 54 | Bay Street sidewalk photograph by author. | 3.5 | 80 | Model of existing wall at St. Basil's Church model and photographs by author. |
| 2.5 | 55 | Bay Street buildings photograph by author. | 3.6 | 81 | Model of peeled away wall at St. Basil's Church model and photographs by author. |
| 2.6 | 57 | Bay Street buildings photograph by author. | 3.7 | 81 | Peeled away surface at St. Basil's Church illustration by author. |
| 2.7 | 58 | Bay Street buildings photograph by author. | 3.8 | 82 | Model of peeled away wall at St. Basil's Church model and photographs by author. |
| 2.8 | 59 | Bay Street materials photograph by author. | 3.9 | 83 | Model of peeled away wall at St. Basil's Church model and photographs by author. |
| 2.9 | 60 | Bay Street materials photograph by author. | 3.10 | 85 | Overall site images with proposal model and photographs by author. |
| 2.10 | 61 | Bay Street buildings photograph by author. | 3.11 | 85 | Axonometric of proposal illustration by author. |
| 2.11 | 62,63 | Evolution of Bay Street illustration by author. base map source: Derek Hayes, <i>Historical Atlas of Toronto</i> . (Vancouver: Douglas & McIntyre, 2008) | 3.12 | 86 | Overall site image with proposal model and photograph by author. |
| | | | 3.13 | 87 | Detail site image with proposal model and photograph by author. |

| | | | | | |
|------|-------|------------------------------------------------------------------------------------------------------------------------------------------------------------------------------------------------------------------------------------------------------------------------------------------------------------------------|------|-----|-------------------------------------------------------------------------------------------------------------------------------------------------------------------------------|
| 3.14 | 88 | Exploration of peeling away east wall of St. Basil's illustration by author. | 4.7 | 105 | Photographs of Entrance portal at Herz Jesu Church source: "Allmann Sattler Wappner: Church of the Sacred Heart." In <i>A+U</i> . 2002:06 No. 381, 123. |
| 3.15 | 89 | Solid and void spaces between Bay Street and St. Basils illustration by author. | 4.8 | 106 | Photographs of back wall at Herz Jesu Church source: Joseph Giovannini, "Congregation of the Faithful." In <i>Architecture</i> . Nov. 2001, 92. |
| 3.16 | 90,91 | Exploration of ramp and stairwell illustration by author. | 4.9 | 107 | Exterior of Herz Jesu Church source: Carline Klien "La Porta Del Cielo," In <i>L'Arca</i> . June, 2003, 64. |
| 3.17 | 92,93 | Exploration of expansion of North Wall illustration by author. | 4.10 | 107 | View of back wall at Herz Jesu Church source: Joseph Giovannini, "Congregation of the Faithful." In <i>Architecture</i> . Nov. 2001, 92. |
| 3.18 | 93 | View of north wall from inside St. Basil's illustration by author. | 4.11 | 107 | Detail of screen printing on exterior portal at Herz Jesu Church source: Joseph Giovannini, "Congregation of the Faithful." In <i>Architecture</i> . Nov. 2001, 92. |
| | | PART 4 | | | |
| 4.1 | 100 | Early Christian worship spaces source: Andre Bieler, <i>Architecture in Worship: the Christian place of worship - a sketch of the relationships between the theology of worship and the architectural conception of Christian churches from the beginnings to our day</i> (Edinburgh : Oliver & Boyd, 1965), | 4.12 | 108 | Plan of St. Gabriel's Church source: http://larkinarchitect.com/ accessed April 2009 |
| 4.2 | 101 | Hereford Map with details source: | 4.13 | 108 | Exterior view of south facing wall at St. Gabriel's Church source: http://larkinarchitect.com/ accessed April 2009 |
| 4.3 | 102 | Table of Contents for Volume 1 of the Summa Theologicae source: Thomas Aquinas <i>Summa Theologica</i> (new York, Henziger Bros, 1948) | 4.14 | 108 | Interior view of south facing wall at St. Gabriel's Church source: http://larkinarchitect.com/ accessed April 2009 |
| 4.4 | 103 | Plan and Photograph of Chartres Cathedral photo by Sonia Halliday, source: Miller, Malcolm. <i>Chartres Cathedral</i> . (New York: Riverside Book co., 1997) | 4.15 | 109 | Interior view of sanctuary at St. Gabriel's Church source: http://larkinarchitect.com/ accessed April 2009 |
| 4.5 | 104 | Exterior wall of Herz Jesu Church source: "Allmann Sattler Wappner: Church of the Sacred Heart." In <i>A+U</i> . 2002:06 No. 381, 123. | 4.16 | 109 | Interior view of narthex at St. Gabriel's Church source: http://larkinarchitect.com/ accessed April 2009 |
| 4.6 | 105 | Plan of Herz Jesu Church source: "Allmann Sattler Wappner: Church of the Sacred Heart." In <i>A+U</i> . 2002:06 No. 381, 123. | 4.17 | 111 | 10 Attempts to Imagine the Inside of My Body #8 oil on wood, by John Brown, part of the Donovan Collection |
| | | | 4.18 | 111 | Lammas #5 chromogenic print, by Luis Mallo, part of the Donovan Collection |

- 4.19 111 **Seuils #5**
mixed media on paper, by Roland Poulin, part of the
Donovan Collection
- 4.20 112,113 **Design Section of North Wall**
illustration by author.
- 4.21 113 **Parti Diagram for North Wall**
illustration by author.
- 4.22 113 **Parti Diagram of changing connections**
illustration by author.
- 4.23 114,115 **Design Section of Ramp**
illustration by author.
- 4.24 115 **Parti Diagram for Ramp**
illustration by author.
- 4.25 1115 **Parti Diagram for analogous experiences**
illustration by author.
- 4.26 116,117 **Design Section of East Wall**
illustration by author.
- 4.27 117 **Parti Diagram of East Wall**
illustration by author.
- 4.28 117 **Parti Diagram of architectonic time**
illustration by author.

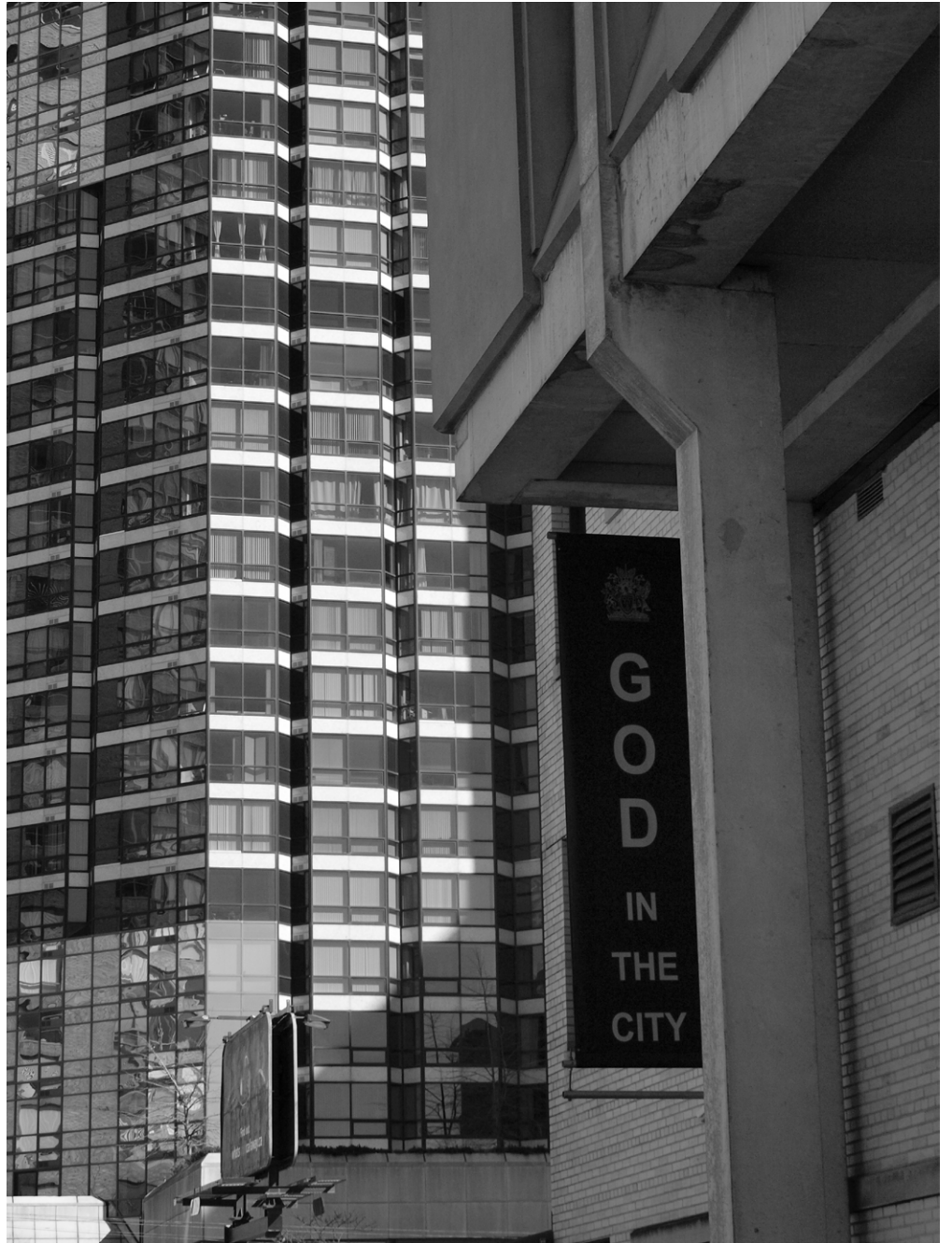

INTRODUCTION:

I believe in God the Father almighty, creator of heaven and earth.

I believe in Jesus Christ, his only Son, our Lord.

*He was conceived by the power of the Holy Spirit and born of the Virgin
Mary*

Under Pontius Pilate He was crucified, died, and was buried.

He descended to the dead.

On the third day he rose again.

He ascended into heaven and is seated at the right hand of the Father.

He will come again to judge the living and the dead.

*I believe in the Holy Spirit,
the holy catholic Church,
the communion of saints,
the forgiveness of sins,
the resurrection of the body,
and the life everlasting.
Amen.*

-The Apostles Creed

And in a contemporary context - in the halls of our institutions, the streets of the city, the square of the public forum - this is absurd. I am left split.

Culturally we struggle to define the role of the sacred in our contemporary lives. Whether it is theology in academia, belief in politics, or religion in a pluralistic society, the boundary between our sacred and our public faces is often a rigid barrier – distinct as the private and public. My identity is similarly split, consisting of a religious self left behind when I step out the front door.

In the teachings of my faith, space and time are created as a harmonious co-existence of the material and divine. The Garden of Eden is the architectural representation of a unification between the sacred and everyday: it meets all physical needs and brings delight. Humanity's fall from grace introduces a dislocation of humans from the immediate presence of the sacred. With this separation comes the architectonic expression of the uniquely sacred and profane. The expulsion from Eden introduces the possibility of conceiving of a space and time *pro fano*, outside the temple, unique and distinct from the sacred.

The effects of this division seem calamitous to me. The narratives of Cain and Abel, the Flood, the Tower of Babel all echo this struggle to exist outside the grace of the sacred. It is in the Abrahamic covenant that a reunification project of tying together the divine and material is begun anew. God's promise to Abraham of land, progeny, and blessing (Gen 12:1-3) establishes the concept of the sacred in a spatial form: the Promised Land. This land guarantees a new place of unity between humanity and God. God is understood at the geometric and metaphorical centre of the Promised Land given to the chosen people. The architectonic expression is a hierarchical model of the cosmos represented in the First and Second Temples: the Holy of Holies in the centre of a sequential series of courtyards expanding outwards to the court of the priests, the court of the Israelites, the court of the Women, and the court of the Gentiles. The material universe flows outwards uniting all material to the divine. Physical space becomes the residing place of the divine, and the space of the everyday is connected to the divine through the hierarchical progression towards it.

The figure of Christ in my faith represents the struggle to overcome the divisions of a hierarchical model, and a renewed attempt to define the relationship between the divine and material. The paradox of the incarnation, the *Logos* made flesh, reinterprets the covenant between God and Humanity by sanctifying all space. In the figure of Christ, the divine dwells within the material as a hypostatic union. This act disrupts the placement of the sacred in the place of the Promised Land, and distributes it across all creation. The possibility of the divine located in the fulfillment of all matter relocates the sacred in time. In time, creation achieves its purpose and the cosmos becomes wholly sacred. I am therefore located in a middle time, after the fall from grace and before the eventual return. The sacred is placed in time, and the space of the sacred acts to affirm this temporal existence. The sacred space of my Catholic faith reifies the presence of the divine as it transforms the material towards an eventual renewal in the fulfillment of time. The material and the divine are linked through this temporal relationship.

Within this concept of time as an instrument of divine fulfillment, the profane is wrapped up in the sacred, nothing exists outside sacred time. Saint and sinner, beggar and priest, are all within the sacred. The incarnation guarantees an indwelling of the divine in all matter. Around the 14th Century however, it became possible within western Christianity to conceive of a time outside sacred time. The writings of theologians such as Duns Scotus and William of Ockham opened the possibility of understanding God as a remote will and authority acting on creation, as opposed to a divine acting from within and revealed through, creation. It became possible to imagine the existence of something not divine, outside God's desire for the cosmos, and therefore outside sacred time.

This possibility of considering something outside sacred time gave birth to the secular. The root of the word comes from the Latin *saecularis* which denotes the time of an age or generation. A *saeculum* was a unit of time which measured the length of a human age, from the moment that something happened until the point in time that all people who had lived at that moment had died. The secular defines a time distinct from sacred time, which is measured by human existence and mortality as opposed to divine renewal. A secular society can be considered as one which exists according to a concept of time from the reference of a mortal perspective. Secular time is separate from sacred time as it uses humanity's lifespan as a reference point, as opposed to the divine. The space of the secular is not tied up in the fulfillment of a divine meaning, but refers to the everyday actions of human experience. It is

figure 0.2 (across)
Cross Section of Bay Street showing St. Basil's Church (on the left) and surrounding fabric

figure 0.3 (xiv)
Bay Street, Toronto

figure 0.4 (xv)
St. Basil's Church, Toronto





by its nature, quotidian, from the Latin *quotus dies* referring to “how many days”. Days, months and years become the units of time in a *saeculum*, which stretches infinitely into the past or future without reference to a divine time.

Divine and secular time become two distinct narratives. The story we tell of where we are, came from and are going is unique to each. As the architectural theorist Paul Ricoeur explores in his essay *Architecture and Narrative*, “recounted time gradually approaches constructed space – and vice versa – to the point where the idea of architectural narrative or of narrated architecture appears as the endpoint of a complex process of approximation.”¹ The narrative of sacred and secular time begins to approximate the constructed experience and vice versa. As Ricoeur suggests, the world of the text is also the world of our own experience². The split between a divine and secular time corresponds to a split between the experience of sacred and quotidian space.

This split is apparent in the fabric of our cities, and the design of sacred space or churches. In exploring the cultural history of architecture, the architectural theorist Dalibor Vesely wrote that “what the book is to literacy, architecture is to culture”³, which is to say that the history of architecture

has always been concerned with creating conditions that support an experience, a way of life, and even a way of understanding ourselves in our relationships to each other and the wider cosmos. These narratives move towards being synonymous with the experience of built form. Because of this, the architecture of the sacred comes to embody a separate and distinct vision of the cosmos from the architecture of the quotidian. This conflict challenges me to exist between two narratives, both sacred and quotidian space deprived of being whole.

As an architect and citizen I desire to reconcile my personal voice with the city, to be whole, and to dwell in both as one. Divine time, when deliberately separated and distinct from the everyday time of human experience, loses its meaning and relevance. It becomes an inward looking process of receiving a divine plan ex nihilo, abstract and numinous. Deprived of connections to the everyday, the structure of sacred time cannot point the material world towards fulfillment. This future becomes destructive and hollow, foreign from any of my day to day experiences.

Similarly the city acquires a denuded existence for me, operating in a quotidian time without larger purpose or goal. Qualities of economy, efficiency, and function respond to



our age's questions more readily than questions of meaning, delight, or purpose. The endless possibilities of quotidian time lose a sense of agency and purpose. I desire to be reconciled. I desire to dwell between divine and secular time; to reconcile my beliefs in the divine with a secular time; to exist between sacred and quotidian space. My architecture must preserve these aspects of dwelling.

Heidegger defines the act of dwelling, in the sense of our mortal stay on earth, as the fundamental act of Being. Split between a sacred and quotidian space, my sense of Being is transient, always moving between narratives of divine and secular time. In his essay 'Buidling, Dwelling, Thinking', he examines how building allows us to dwell. Dwelling implies not only construction but inhabitation. We "dwell" when we become connected with a "space", and it becomes a recognizable "place." In the same manner as thinking, building acts to preserve structures of Being so that we may dwell⁴. Dwelling preserves the 'simple oneness' of earth and heaven, divine and mortal, the depth and breadth of our lives.



This thesis explores one border in Toronto between sacred and quotidian space. Architecture is a cultural expression of this split and an active participant in it. I seek to build between this split, to reconcile time in the contemporary city as belonging both to the secular and sacred so as to create a place of dwelling, into which the earth and sky, divinities and mortals, can come together.

“By a primal oneness the four – earth and sky, divinities and mortals – belong together in one.”

Earth is the serving bearer, blossoming and fruiting, spreading out in rock and water, rising up into plant and animal. When we say earth, we are already thinking of the other three along with it, but we give no thought to the simple oneness of the four.

The sky is the vaulting path of the sun, the course of the changing moon, the wandering glitter of the stars, the year’s seasons and their changes, the light and dusk of day, the gloom and glow of night, the clemency and inclemency of the weather, the drifting clouds and blue depth of the ether. When we say sky, we are already thinking of the other three along with it, but we give no thought to the simple oneness of the four.”

The divinities are the beckoning messengers of the godhead. Out of the holy sway of the godhead, the god appears in his presence or withdraws in his concealment. When we speak of the divinities, we are already thinking of the other three along with them, but we give no thought to the simple oneness of the four.

The mortals are the human beings.. They are called mortals because they can die. To die means to be capable of death as death. Only man dies, and indeed continually, as long as he remains on earth, under the sky, before the divinities. When we speak of mortals, we are already thinking of the other three along with them, but we give no thought to the simple oneness of the four.”

-Heidegger

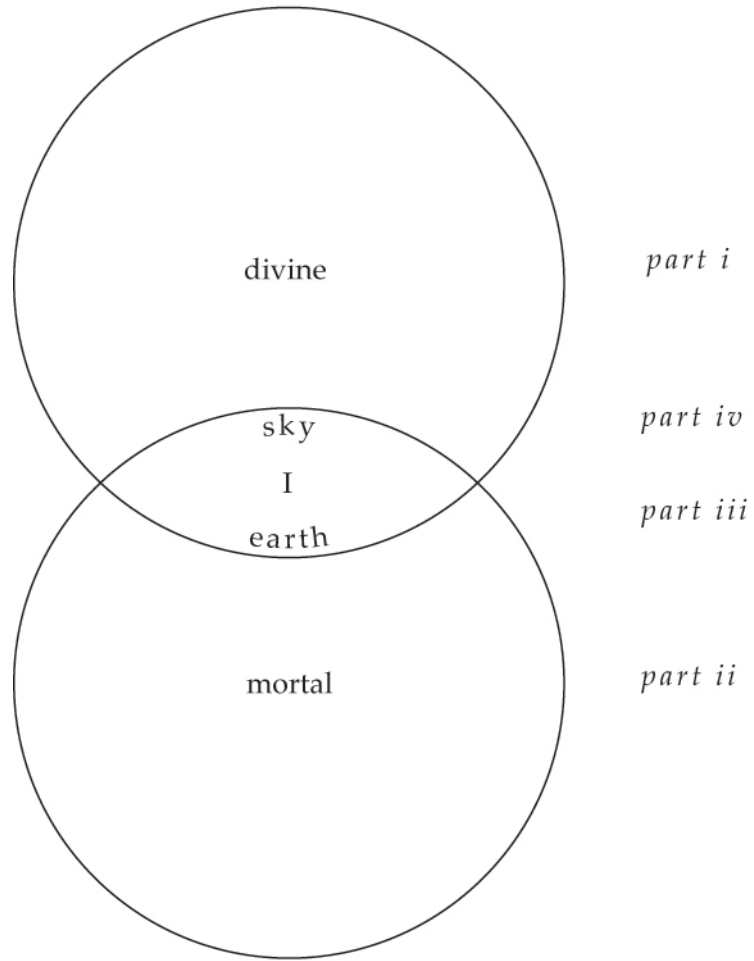

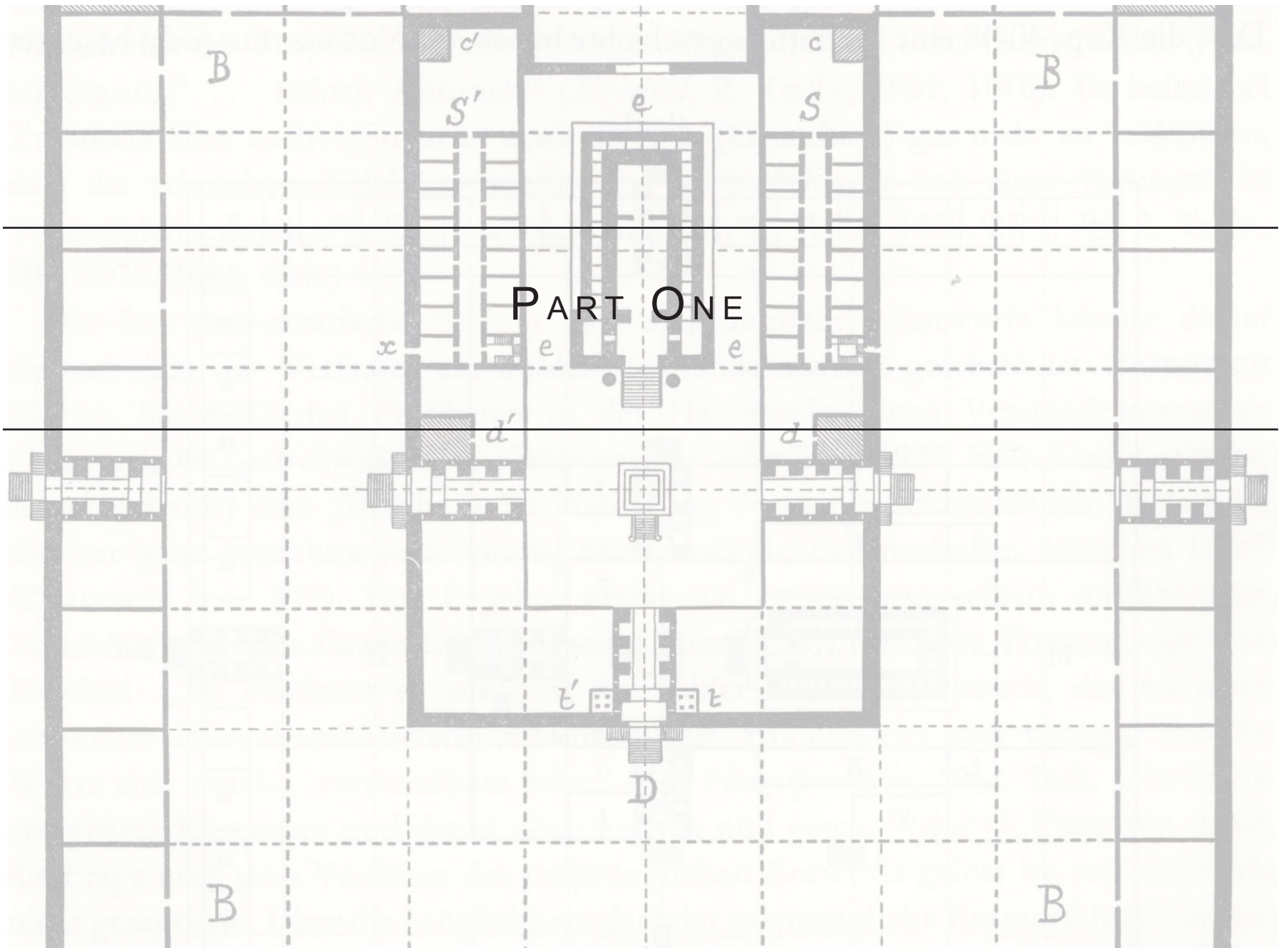

divine; the sacred

The divinities are the beckoning messengers of the godhead. Out of the holy sway of the godhead, the god appears in his presence or withdraws in his concealment. When we speak of the divinities, we are already thinking of the other three along with them, but we give no thought to the simple oneness of the four.

§198, §200 The Cleansing of the Temple
Mk 11:15, Mt 21:12, Lk 19:45, Jn 2:13

¹²Then Jesus entered the temple and drove out all who were selling and buying in the temple, and he overturned the tables of the money changers and the seats of those who sold doves.

¹³He said to them, "It is written, 'My house shall be called a house of prayer'; but you are making it a den of robbers."

-Mt 21:12-13

THIS NARRATIVE IS FOUND in all four of the gospels. The synoptics place it at the start of the passion week, precipitating the death plots against Jesus, whereas John places it at the start of Jesus' ministry to introduce Jesus' confrontation with the Jewish authorities. In all four of the gospels, Jesus enters the temple in Jerusalem, and casts out several figures. The four gospels each provide a unique list of those cast out; while Luke only lists "those who were selling things there", Mark and Matthew include those buying, money changers, and those who sold doves, while John expands the list to include all those who conduct business, and the sellers of sheep and cattle. The temple grounds are being cleansed, but the question of what the gospel writers intended to cleanse, and for what purpose cleansing was needed is at the heart of this passage.

Cleansing or purification formed an integral part of Jewish tradition. Purity implied being "free from any physical, moral, or ritual contamination"¹. While most often relating to the impurity of an individual, objects, spaces and communities also required purification. Any defilement which represented a rebellion against God's law would have needed a set of rites administered in order to be cleansed.

In the Johannine gospel, the author attaches an allusion to the resurrection in Jesus' rebuttal to his critics: "destroy this temple, and in three days I will raise it up". The sacrifice of the crucifixion is juxtaposed against the animal sacrifices in the temple. The doves, sheep, and cattle cast out would have all been for use within the temple as ritual sacrifice (an aspect of the rite of purification)². This image suggests an apocryphal aspect of the cleansing.

While there is no doubt an allusion to the end of the Jewish sacrificial system in Christ, there are several other objects "cleansed" which are unaccounted for by this understanding. The Johannine gospel objects to the temple as a "marketplace" from the Greek *emporion* meaning "house of business"³. These figures were more associated with the temple's role as a social, political and economic structure.

The quotation used by Jesus in casting out these figures from the temple is from Isaiah 56:7 “for my house shall be called a house of prayer for all peoples”, and Jeremiah 7:11 “has this house, which is called by my name, become a den of robbers in your sight.” Both of these passages deal with a definition of the sacredness of the Temple. Isaiah grants foreigners and eunuchs access to the Temple so long as they observe the Sabbath and rules of Jewish law, while Jeremiah emphasizes the exclusion of those who do not keep the Mosaic covenant (robbers). The authors of Luke and Matthew, who used the gospel of Mark as a source, chose to exclude “for all nations” from the Isaiah passage. The effect is to emphasize “a house of prayer” which is contrasted against the “robbers” of Jeremiah. This suggests that Jesus is cleansing the temple of activities unsuited to prayer; “of all unsuited service of mammon.”⁴

The organization of the Temple included a large forecourt for the types of activities occurring in this passage. The general populace only had access to the Temple courts - the rest being reserved as the residence of God -which acted as a public building in a political and economic sense: “Because ancient Israel even during the monarchy, was not a secular state, the Temple played an integral role in the organization, legitimation, and administration of the national community.”⁵

In this sense, “cleansing” implies a division of this structure. There are activities not concerned with prayer which thereby do not have a role in a house of prayer. In the act of cleansing, the gospel writers are suggesting an elimination of the social and economic aspects of the temple grounds, so that they may be purified for sacred purposes.

Reflection

THIS SPACE - made of stone, glass, wood and plaster, materials no different from any other space - evokes something wholly other. Across an invisible line I become aware of the mystery present here. I register light-sound-smell as before, but it now possesses an added dimension: light of colourful hues, sounds that reverberate, thick and heavy smells. This is surely an appropriate place for “a house of prayer.” It is not crowded by the haranguing voices of buyers, sellers and money changers.

Jesus’ bitter rage is nevertheless disturbing. Can sanctuary be so exclusive? If the temple is truly set apart from unsuited activities, then are there aspects of my identity similarly unsuited? Like the filtered light, amplified sounds, and masked smells, I sense my own self being separated out. I identify with these agents of debate and negotiation, these money changers, buyers, and sellers. They struggle to apply reason and order to the temple, exchanging those practical necessities. The experience of the ineffable presence of God is deeply sensual, and yet somehow missing. The quotidian is always within. I am left divided.

What is the nature of the sacred and what is its relationship to the quotidian? Is it possible to inhabit both?

iv. Defining Sacred Space and Time

THE DIVINE APPEARS or withdraws in the built fabric of our cities. Whether through material, social, or emotional singularity, we somehow register the sacredness of a space. However, defining what makes a space sacred and the act of constructing sacredness, is fraught with complexities. Not only are sacred spaces contested spaces, often appropriated by different groups with different understandings of the space, but they as a whole suffer an increasing amount of neglect in contemporary culture. Even though the role of religion is drastically changing in a secular society, communities continue to appropriate and define sacred spaces in their lives. Certainly this includes churches, temples, and mosques, but also extends to cultural icons, the *sanctuary* of the home, or the geography of the land itself. Inscribing the sacred into our built environment continues to be an act fundamental to our identity and humanity: “the sacred has been and continues to be a powerful cognitive space in the landscape of the imagination.”⁶ Defining a working understanding of how the sacred is manifested in architecture, and a hermeneutics for reading and working with it, is therefore necessary.

figure 1.1 Sections

St. Basil's church is Toronto's third oldest church. Located in the downtown core, the church and its associated office spaces are a part of St. Michael's University College, affiliated with the University of Toronto. St. Basil's currently serves approximately 3000 registered members across a wide demographic.

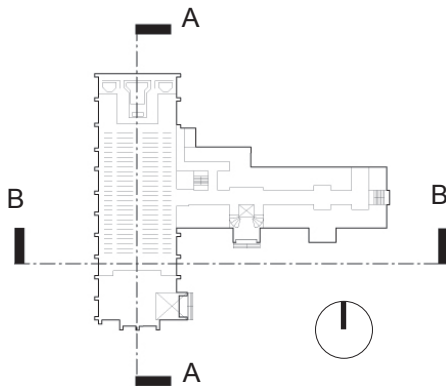

One of the first challenges in defining sacred space is recognizing its instability. As the architectural historian Louis Nelson discusses, there are many forces involved in an understanding of the sacred, and we must avoid “the common misconception among designers that the genesis of sacred meaning is found in the design process and that an architectural form can itself be sacred.”⁷ This process of inscribing meaning over time demonstrates the spacio-temporal process by which sacred space is created and grows⁸.

Sacred space registers memories, identities and beliefs of the community, the cultural context, the institutional voice, and the designer. Architectural forms and spatial relationships act as placeholders of these narratives. Over time some of these forms can become established symbols, universally understood as sacred; a steeple, vaulted roof, or stained glass all help to inscribe sacredness through their iconic status. However, it is the content of these inscriptions and the many specific elements unique to a particular space which characterize the sacred. Kieckhefer's uses the idea of *Theology in Stone* to title his seminal work on an understanding of sacred architecture. This idea implies that the content of belief can be inscribed and read in architectural elements. Kieckhefer argues that “entering

into a church is a metaphor for entering into a shared world of symbolic narratives and meanings, somewhat like entering into a story and discovering the richness and internal coherence of its structure.”⁹ Sacred architecture tries to embody and preserve these narratives in built form.

In the case of St. Basil’s Church (figure 1.1), the space is organized around a longitudinal axis. The long procession towards and away from the centering focus of the altar, tabernacle and cross create what Kiekehefer calls a ‘kinematic dynamism.’ Movement along this axis co-ordinates the narrative structure of the space through its strong directionality. Viewing the church across its short axis (section B-B) one is entirely focused on the altar of sacrifice. Along this axis of movement (section A-A) stained glass windows, stations of the cross, small shrines and statues give definition to this journey. These elements layer images and symbols onto movement which is both general (depictions of biblical passages) and specific to the site (patron saints, shrines to the founder). These elements act to generate narratives which define the sacred.

These narratives are cosmological, incorporating memory, identity and belief.

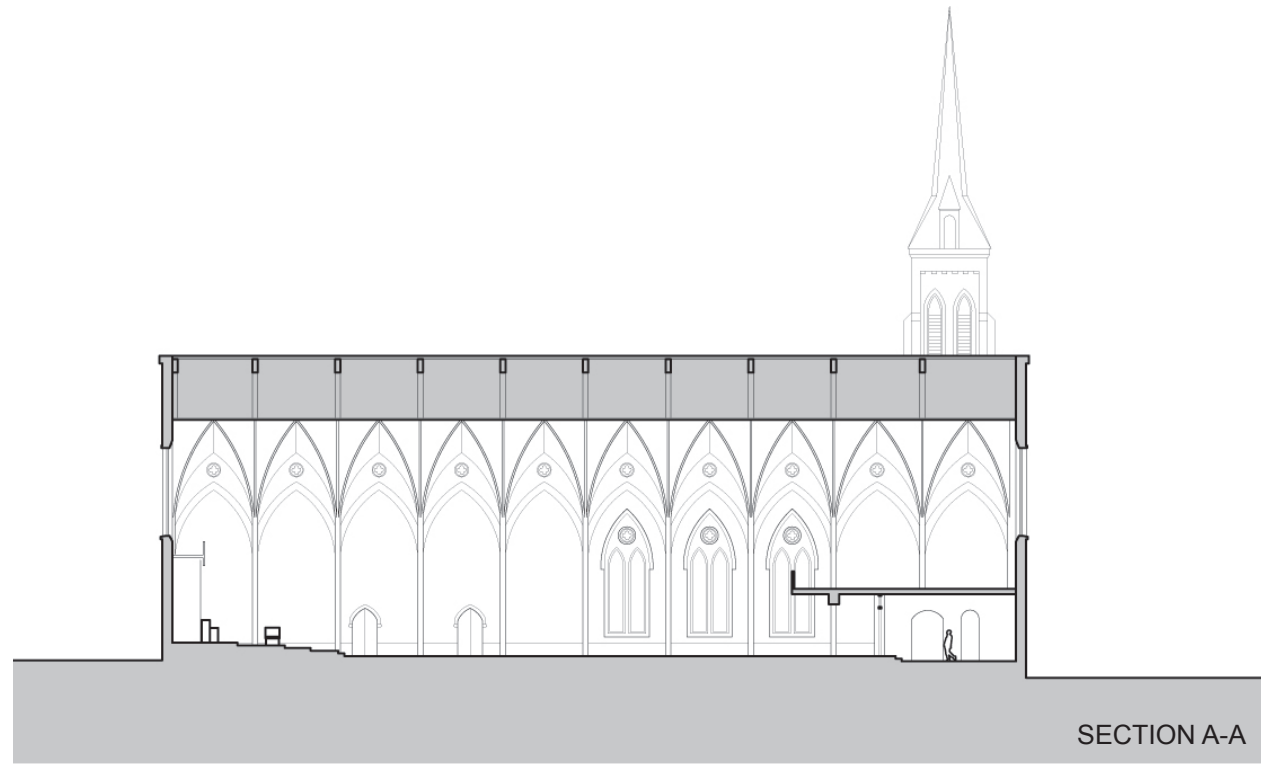
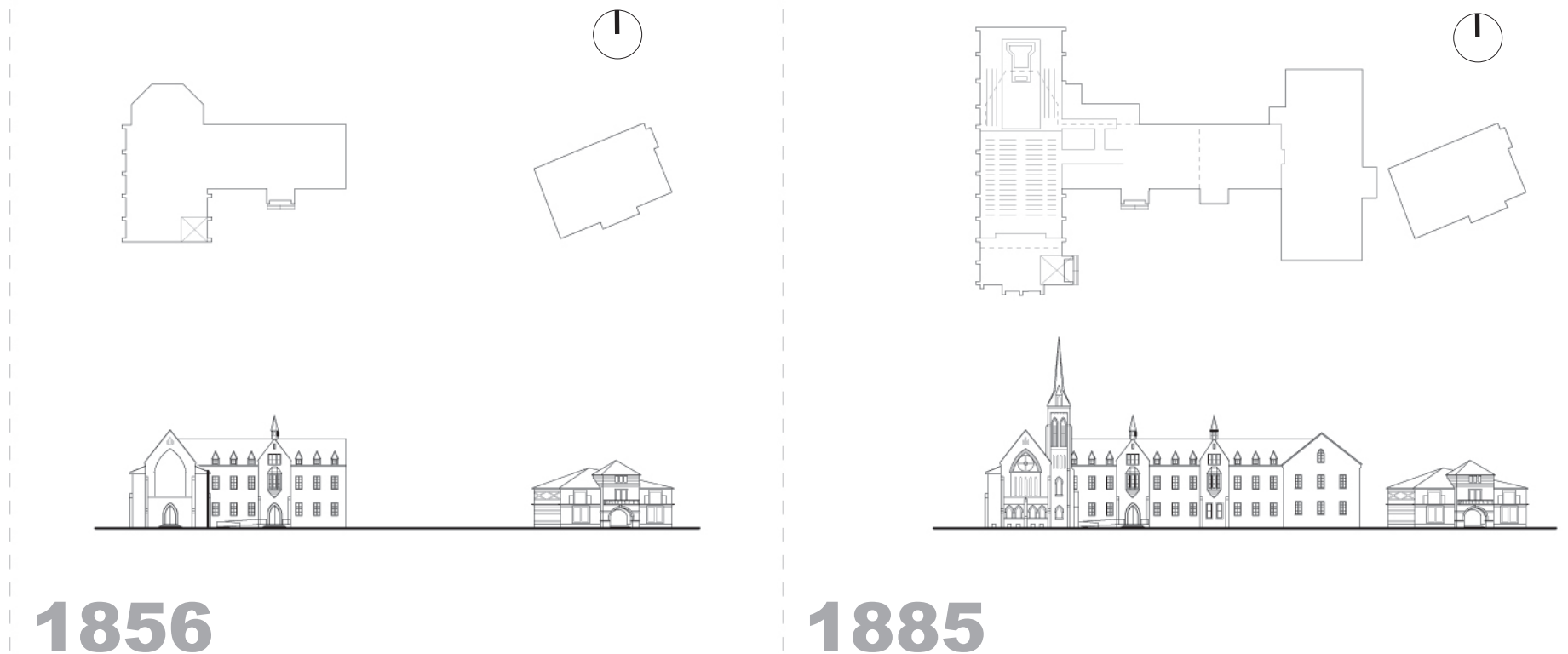

figure 1.2

St. Basils has radically changed since its founding in 1856 as a boys college. Built on Clover Hill, a farm north of the city, the church and college sat amidst a bucolic landscape. The Terauley St. extension of 1923 (now Bay St.) annexed part of the property incorporating the church and college into the downtown core of a busy city.

These terms can be understood in their close relationship to time as they act to place the material world into sacred time. The role of memory is to preserve narratives of origin relevant to the present and future. Identity reflects a momentary snapshot of a particular present condition in the context of its past and future. Belief relates the hoped for or promised future to the present and creates a continuous progression with memory. This cosmological narrative incorporating memory, identity and belief, relates the material world to the sacred. By reifying memory, identity and belief in sacred architecture, the material world becomes positioned in the narrative of sacred time¹⁰.

A sacred space in the Christian tradition therefore is one which reifies, both physically and conceptually, qualities of memory, identity and belief, or in other words, past, present and future. Important to this definition is that these aspects relate the social, political, and cultural aspects of a mortal, physical world, through time, to an immortal, ineffable reality of the holy. St. Basil's church in its evolution from a private college to a public worship space



reveals the changing cultural and social roles of groups in relation to the holy (figure 1.2).

As a school, separate entrances for teachers, students and the wider community created a hierarchy of space and access (1885, 1923). Alterations to the altar (1971) reveal the changing role of the community. Important to understanding the sacred is how these changes alter experiences of the 'holy.' This secondary reality is often difficult to discuss, it is by its nature ineffable. In Rudolph Otto's book *The Idea of the Holy* this is investigated. Otto uses the term 'numinous' to encapsulate it. It is beyond the idea of 'the good' and implies an "overplus of meaning... 'the holy' minus its moral factor or 'moment', and ... 'minus' its 'rational' aspect all together."¹¹

For contemporary sacred space, the numinous holds particular importance. The numinous has become the single most important aspect of sacred space as it is experienced and interpreted. The narratives inscribed in sacred space, which relate the mortal world through time to the holy, have been reduced in importance. Feelings of awe, majesty, or mystery have become the limited vocabulary of the sacred. The architectural experience of the numinous is the one which most will react to and identify as primal to their understanding of the sacred. How this understanding of sacred space has affected the built landscape of both sacred and quotidian spaces is worthy of greater reflection.

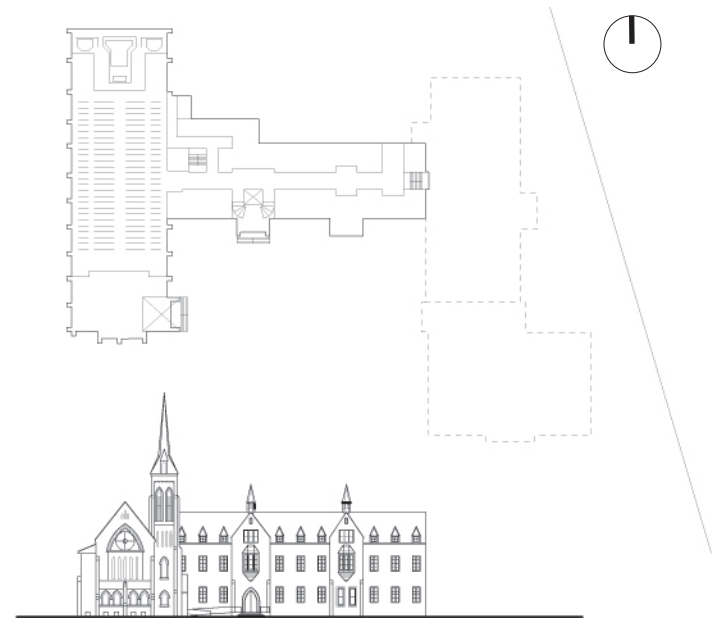
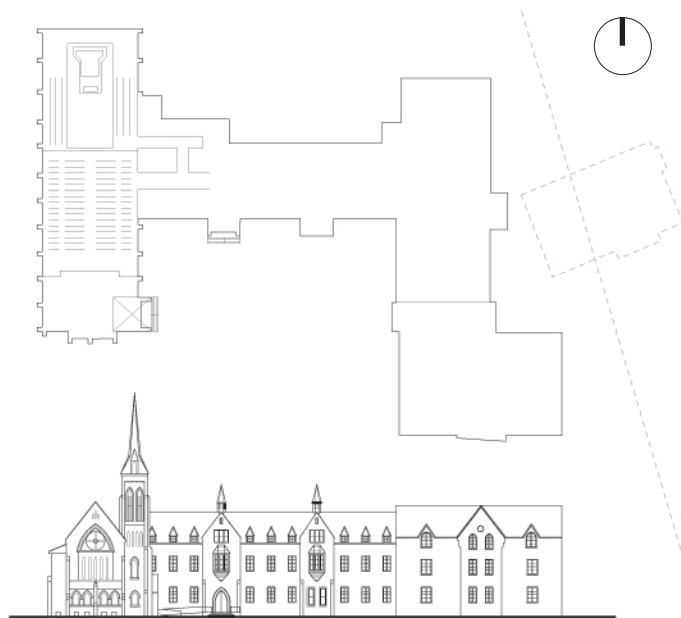

1923

1971

v. Interpreting Sacred Space

IN SEEKING TO READ sacred space, its changes and its meaning, three interpretive models have been proposed – one generated within comparative religions, another in aesthetic theory, and a third in the dynamics of relationship. Each seeks to read how the artifacts and experiences of the everyday become related to the narrative of sacred time. All three differ however, in the elements they use to register this process. Eliade's book *Sacred and the Profane* sees sacred space as having universal elements, communicating ontological truths about the relationship between the world and the cosmos. The structures of sacred time are modeled metaphorically in the architectural form. Kiekehefer's book *Theology in Stone* explores symbolic and aesthetic impact in communicating the sacred. As the symbols, colours, and experience of the architectural space shift through time in sequence or juxtaposition, a living theology can be discerned. Finally, Jean Kilde's essay *Reading Megachurches*¹² suggests sacredness can be determined through an examination of relationships. Individuals' movement and interactions with each other in sacred space correlate to spatial narratives supported by the architecture. Each model of interpretation helps explain how architecture supports, inscribes, and communicates sacred space.

One of the most often cited texts in the discussion and construction of sacred space is Micrea Eliade's *Sacred and The Profane*. The text originates from the study of comparative religions and argues for a common ontological truth to the human conception and expression of the sacred. Through a wide survey of religions, beliefs and practices, Eliade attempts to demonstrate a uniformity in sacred space. Eliade identifies the symbolic structures of the *axis mundi*, an upward axis which affixes the divine to a particular location, and the *imago mundi*, which models the world around that divine encounter. The *axis mundi* creates a fixed centre to those inhabiting the world of the sacred allowing "communication with the gods"¹³ and the act of fixing it is "akin to creation"¹⁴. Around this axis, therefore, sacred space models a new reality or existence in the world for 'sacred man'. "The sacred reveals absolute reality and at the same time makes orientation possible; hence it founds the world in the sense that it fixes the limits and establishes the order of the world."¹⁵

These elements model a formal structure of the sacred. It assumes that however sacred space is adorned or inhabited, it has an underlying order and organization which acts

figure 1.3.

*The organization of St. Basil's church models a linear path. The church architect Rudolph Schwarz in his book *The Church Incarnate* entitles this model the Sacred Journey:*

"a world which has already ceased to be sheltered and sheltering space turns into the path leading toward the goal which lies 'ahead.'"

The main sanctuary is placed in the inbetween on a strong vector. The community gathers on a journey towards a projected future in the cross and tabernacle which are placed at the end of the vertex. These elements suggest a destination beyond. Time is modeled as a linear progression towards an eventual sacred time. The architectonic structure models a theological interpretation of time - our time as an inbetween after the fall and before the second coming.

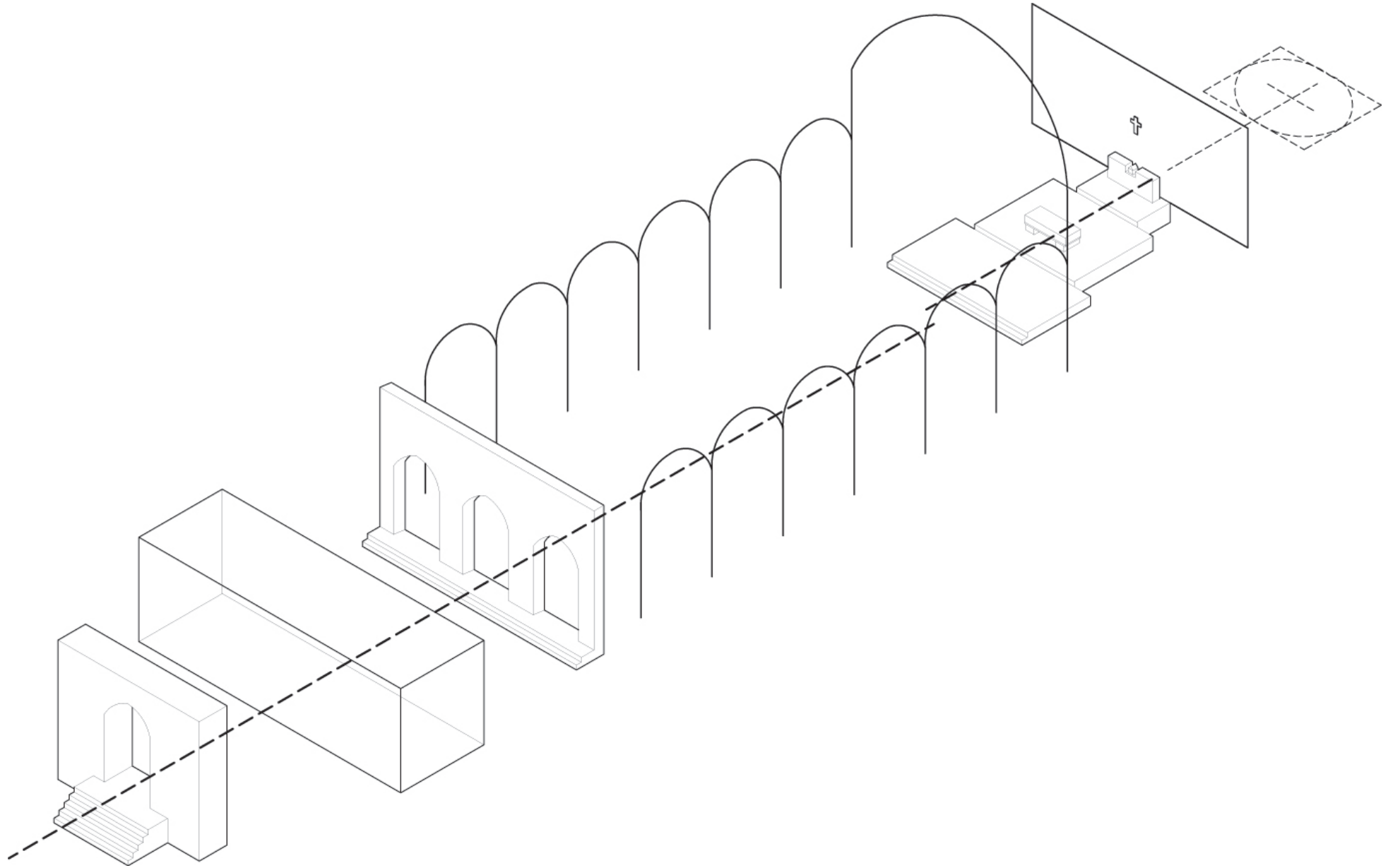

as a universal model of the relationship between the sacred and everyday. The *axis mundi* and *imago mundi* are geometric ordering principles which define the sacred. Interpreting metaphorical structures helps to interpret the meaning of sacred space. Defining the structure of sacred time (and how the material world is caught up in it) through an identical architectural structure, creates a direct analogy. This hermeneutic looks to interpret the ordering and arrangement of sacred architecture as an analogy for the order in the theology (figure 1.3). Such a hermeneutic sees sacredness manifested in objects and materials which are supposed to communicate an alternative reality, or evoke specific memories of divine communication, creation, and sacred orientation. The drawback of this method is the application of a universal conception to all sacred spaces. Inevitably this alienates the individual nature of sacred space, and the variations that do occur. As Nelson explains, “The importance of the periphery in the making of multiple or even conflicting religious meanings, the possibility of sacred meanings dislocated from worship of the divine, and the role of human agency in the construction of the sacred have little room in Eliade’s model.”¹⁶

One of the most common models for understanding sacred space is also one of the most historic. Sacred space (and sacredness) can be interpreted through the platonic association with beauty¹⁷. Kieckhefer’s chapter ‘aesthetic impact’ in his book *Theology in Stone* notes that “beauty is the only symbol we humans can devise that illuminates the transcendent.”¹⁸ This hermeneutic relates sensory impact to theology, and is fundamentally a phenomenological reading of sacred space. Height, light, acoustics, materials, texture and colour all help to communicate meaning. The unique or beautiful creates emotional responses of awe, mystery, humility or comfort. How these sensory impacts change according to time incorporates them into a narrative. The sequence, juxtaposition, and intensity of these responses help discern a theology.

The phenomenological changes in sacred space over time help to connect the sensations of the material world to a narrative of sacred time. The liturgical season and its cycle of festivals, colours, symbols and related objects associate the everyday passage of time to a sacred meaning (figure 1.4). Even at the scale of a single day, the changing sounds and light of a church are indicators of a connection between the material and sacred time. This hermeneutic responds to the physiological aspects of sacred space. The sensory responses and their affective sensations define an order and program. The nature of these affective

figure 1.4

St. Basil’s church changes on a daily, weekly and yearly calendar. The changing qualities of light, colour, sound, and symbol are integral to the experience of a sacred time.

Mass times throughout the week create a cycle of activity throughout the day. Weekend masses are broadcast on a local Television station, altering the lighting and sound of the church for recording purposes. A yearly cycle of festivals forms the liturgical seasons which move between ordinary time, preparation seasons (advent, lent) and festival seasons (christmas, epiphany, easter). Liturgical vestments, and decorations correspond to this yearly cycle in their themes and colours creating a seasonal rhythm.

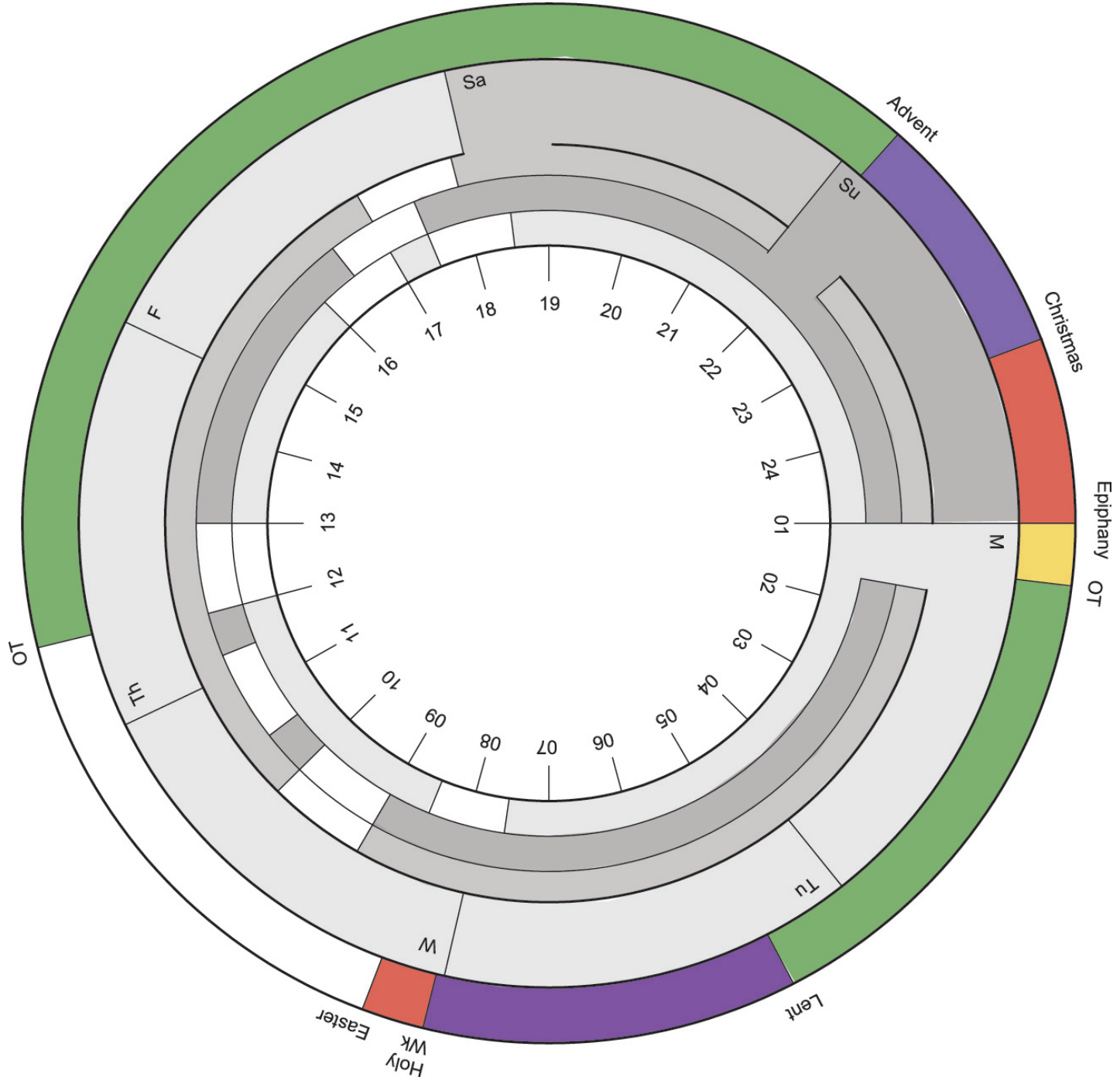

responses however, remain cultural constructs - the idea of beauty, for instance. They are as much a reflection of the subjective individual as the theology, and it is often difficult to distinguish which is the more compelling. These ideas shift and change so radically that it can become difficult to clearly interpret sacred space

Jeanne Kilde's article *Reading Megachurches*, discusses another hermeneutical method adapted to reading contemporary megachurches which may have less formal ordering structures and more generic qualities. Its methods however, seem relevant and applicable to all sacred space. Kilde interprets the sacred based on the dynamics of relationship. For Kilde, the necessary components of sacred space, the "creed, or beliefs and doctrines; code, or ethical and moral strictures; and cultus, ritual practices"¹⁹ can be read in the relationships between the powers of the individual, social, and divine. The powers given to each of these figures, and the way the architecture enables that power in the relationships, adds to an understanding of the creed, code and cultus (figure 1.5). Kilde describes the emphasis given to circulation and rapid movement of individuals in the contemporary Megachurch having "ramifications with respect to the individual religious experience of members, specifically in defining a sense of personal power that an individual may experience within these buildings." This sense of power effectively communicates and makes present a contemporary theology of the evangelical church²⁰.

Kilde is suggesting that the relationships supported by the architecture can be representative of the theology of a sacred space. The spatial dynamics of movement describe a sequence of relationships. Just as the changing of the liturgical space through time revealed phenomenological changes, personal movement through time sets up a series of relationships revealing a theology. Thus this method seeks to find meaning not only in the architecture, but in the relationships it allows to its occupants. Built form can facilitate or inhibit these movements. It becomes difficult however, to fully predict what relationships these movements may generate. Assembling can be interpreted as both a collective gathering and a 'herding'. Relying on subjective experience, the affective response to relationships are ever changing.

Each hermeneutic provides insights into the creation of the sacred in architecture. While the focus for each is unique - be it iconic representations, material experience, or relationships - all three methods help explain how sacred space is registered. These methods

help to enlighten the meaning of sacred spaces. What becomes immediately apparent through all three models is that while theologies and communities widely differ, sacred space acts to preserve a relationship between the material and the holy. The presence of the holy in some ways provides the key evidence for distinguishing between a sacred space and a 'grand space.'²¹

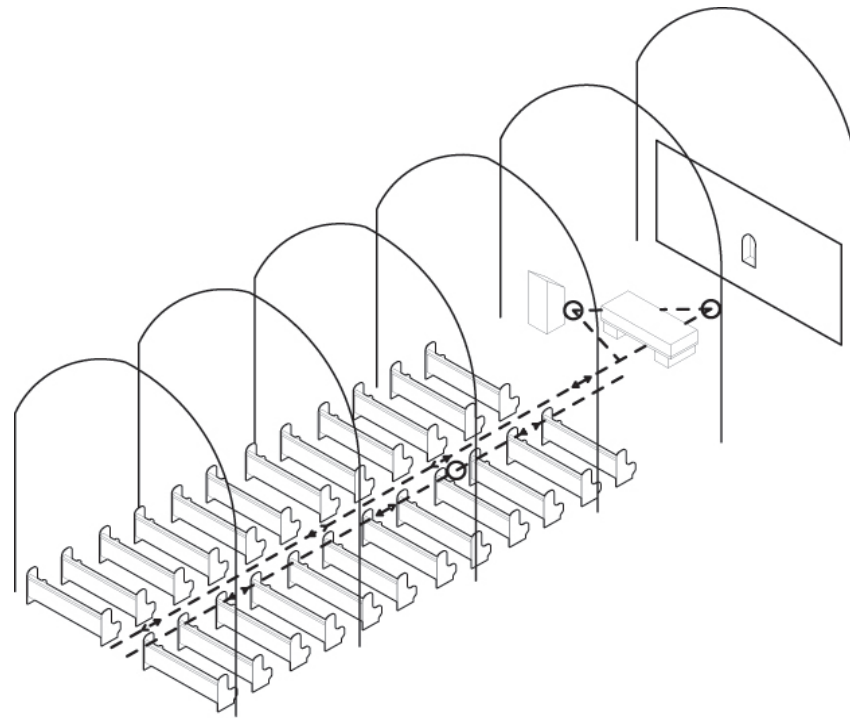

figure 1.5.1 (top)
The relationships between individuals in the cycle of movements which form the rituals of St. Basil's church reveal a theology.

A gathering for mass at St. Basil's creates a large group oriented equidistantly from each other, along a common axis. The community along with a leader who stands apart, progress along this central axis.

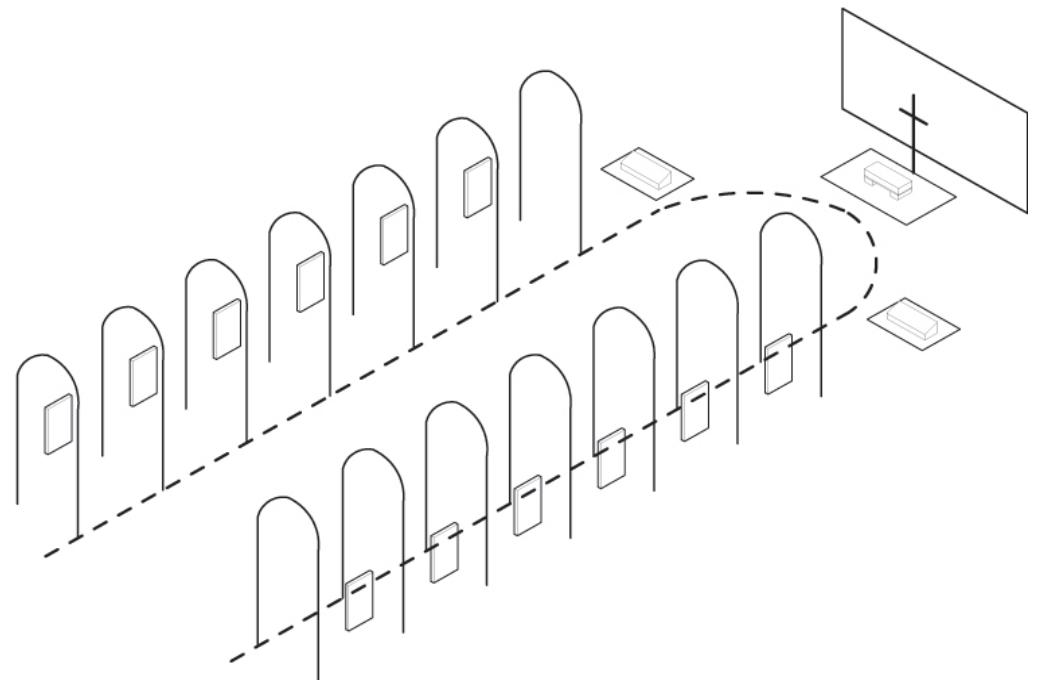

figure 1.5.2 (bottom)
Smaller shrines and the stations of the cross located on the periphery of the sanctuary create a secondary sequence of motions. This path is a cyclical, personal journey which consists of an individual walking privately, following a visual narrative. The path is both personal and communal as the path and narrative are integral to the community as a whole.

vi. The Numinous

SACRED SPACE ACTS as the locus for many cultural, political and social concepts. What differentiates it so clearly from other buildings laden with these significances is the presence of an indescribable experience of the holy. In his book *The Idea of the Holy*, Otto tries to define the sensation, cause, and effect of the numinous. It is an emotional response which is both an indefinable feeling as well as a common experience towards certain stimuli. Otto labels this feeling 'creature feeling' and describes it as "the emotion of a creature, submerged and overwhelmed by its own nothingness in contrast to that which is supreme above all creatures"²².

In order to describe the 'cause' of this feeling and the qualities which manifest it, Otto describes the numinous as the "mysterium tremendum": an overpowering experience of mystery. The tremendous nature of this experience is similar to the sublime and can manifest itself as an awefulness, majesty or urgency.²³ These qualities necessarily terrify, amaze, or inspire. It is in response to something mysterious, and wholly other, that these qualities express the numinous.

Determining the means of expressing these qualities, Otto acknowledges, is indefinite: "There is, of course, no 'transmission' of it in the proper sense of the word; it cannot be 'taught' it must be 'awakened' from the spirit."²⁴ The numinous in art it must be induced, incited or aroused; it cannot be expressed symbolically or metaphorically. The experience of miraculousness, astonishment, or grandeur, all point to the 'Other', ineffable character of reality. The arts have always held a fascination with the numinous, and Otto recognizes the relative success of architecture in capturing this sense throughout history:

"in the arts nearly everywhere the most effective means of representing the numinous is 'the sublime'. This is especially true of architecture, in which it would appear to have first been realized. One can hardly escape the idea that this feeling for expression must have begun to awaken far back in the remote Megalithic Age. The motive underlying the erection of those gigantic blocks of rock, hewn or unworked, single monoliths or titanic rings of stone, as at Stonehenge..."²⁵



figure 1.6 Chapel at Holy Rosary Complex, Trahan Architects.

figure 1.7 Chapel of St. Ignatius, Stephen Holl Architects,

figure 1.8 Church of Light, Tadao Ando.

figure 1.6



figure 1.7



Otto's description of the numinous however, always recognizes it as deeply concerned with our experience of reality. 'Creature feeling' is an affective response, but for Otto it is necessarily an objective rather than personal feeling: the numinous is the object outside the self which is the necessary cause of this feeling. Otto maintains that the numinous always relates back to the material, revealing the sacred in the material. In Otto's example of the numinous in architecture, the gigantic blocks of Stonehenge reveal the sublime in astronomical movements and temporal cycles. These natural phenomena do not alone define the 'wholly other' but are attempts to connect the numinous to its reality present in physical objects. According to Otto, the numinous is a unification of the subjective experience and objective understanding expressed in sacred space.

Contemporary sacred architecture however, has seen a division in this unitive aspect of the sacred. Twenty-six years after *The Idea of the Holy*, and written from the perspective of comparative religions rather than theology, Mircea Eliade recognizes the numinous, as well as a wholly other world not connected to the sacred. In *The Sacred and Profane* (1959), sacred space is wholly other, the "opposite of the profane,"²⁶ which modern man can be either in or out of. For Eliade, the numinous sensation can be independent of a social or cultural narrative, depending on a personal viewpoint: the 'homo-religiousus' is a distinct way of 'being.'

The impact of 'The Sacred and Profane' was immense. The text remains one of the most often cited works in the discussion of contemporary sacred space. The effect of Eliade's text was to emphasize the affective sensation of *mysterium tremendum* of Otto's numinous without its connection to a reality present in physical objects. The reality of the 'homo-religiousus' was distinct and separate. This served to understate the objective material implications of the numinous and emphasize the subjective emotional response.

This understanding of the numinous represents a significant design element in contemporary sacred space and part of an ongoing relationship between sacred space and a secular society. The expression of an ineffable which is unconnected to a social or cultural narrative plays a dominant role in the contemporary language of sacred space. Recent projects including Stephen Holl's St. Ignatius Chapel (1997), Tadao Ando's Church of the Light (1988) and Trahan architects Chapel at the Holy Rosary Complex (2004)²⁷ all demonstrate this proliferation of a sacred space which focuses on the numinous. The architectural language of

figure 1.9 St. Basils Interior, 1907
Prior to the enclosure of the ceiling, light poured in from above.

figure 1.10 St. Basils, Interior. 2008
A Shrine at the end of the west aisle.

figure 1.9

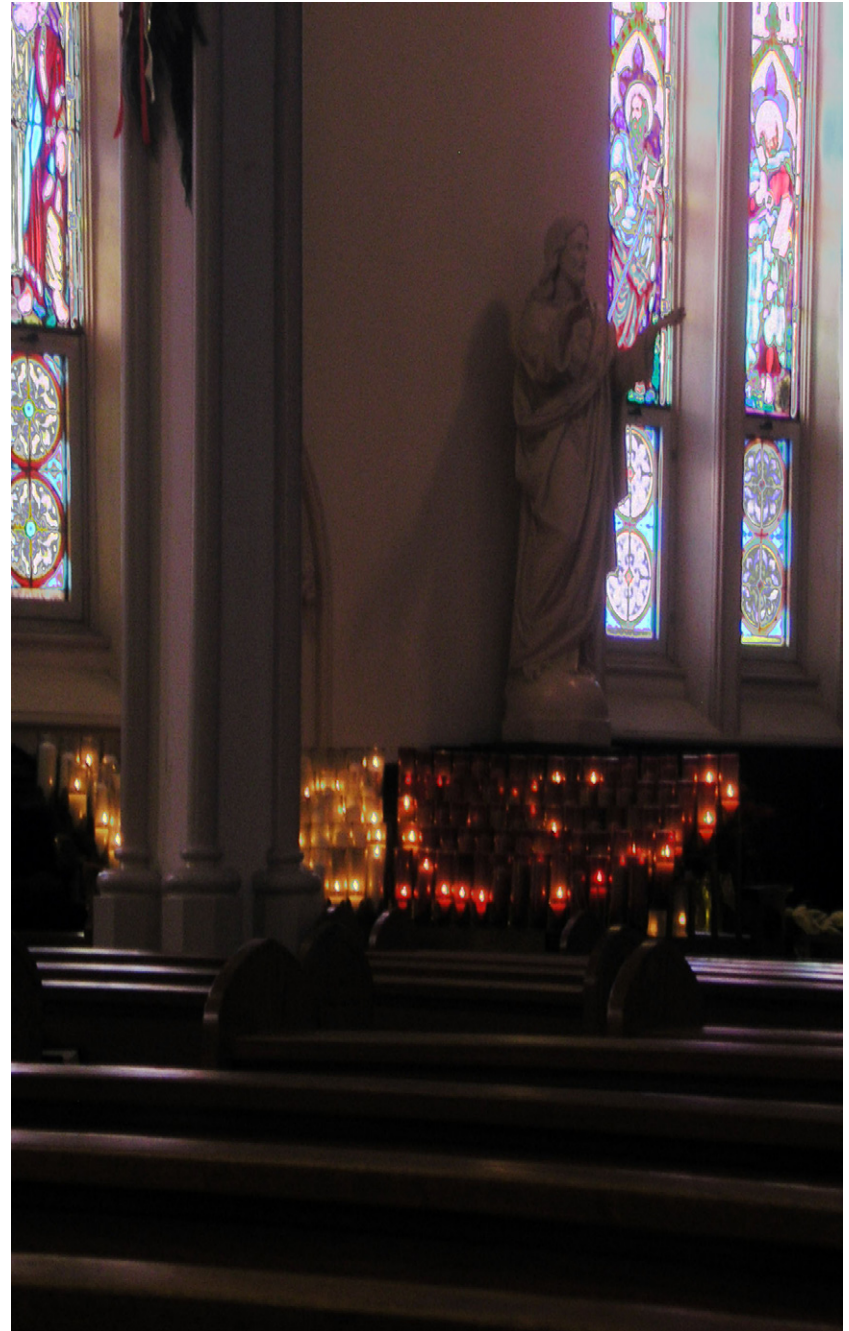

these spaces therefore becomes intent on expressing the sublime moment of religious feeling rather than narratives of memory identity and belief.

It is no surprise therefore that all three projects attempt to use form and light to create dramatic moments of awe. Each uses forms to bring light into the sacred space from unusual directions or unexpected ways. Light becomes a powerful tool for expressing the ineffable of the sacred. While Trahan and Ando's churches are relatively stark, Holl uses colours to give the light varying emotional qualities. Each sacred space moulds light and form to generate a sublime experience. Form and light become remade from their quotidian expression, into ineffable experiences of something 'other.'

The result of these designs is a remarkable tuning of the edge conditions for these spaces. All three projects have physically massive walls or roofs. At points, the chapel walls at the Holy Rosary Complex are over one meter thick allowing light to reflect down and apparently glow from the chiseled concrete. The added depth of the elaborate roof at St.

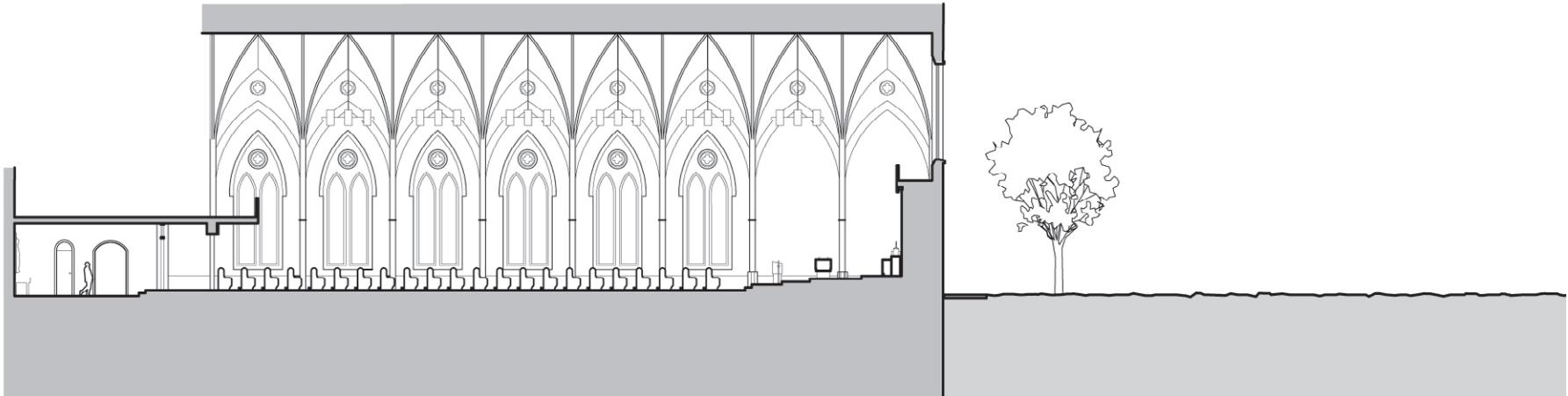
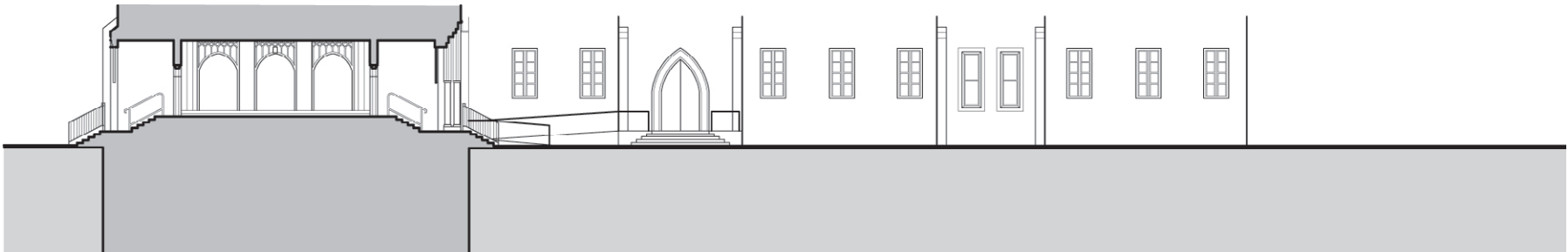
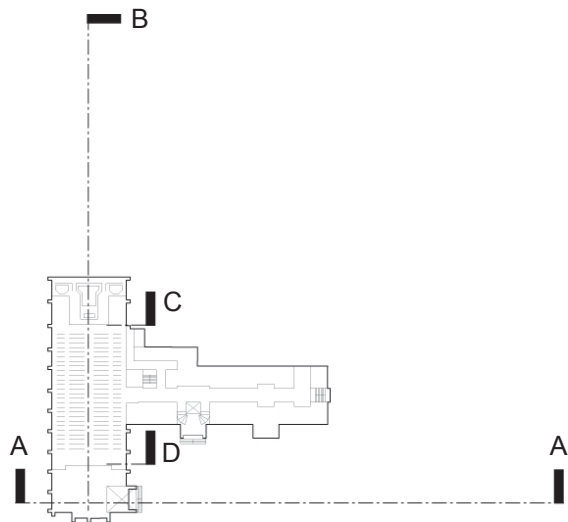

Ignatius' Chapel becomes necessary to give the light subtle colour variations. In each case, the distinction between the numinal and the everyday aspects of light is moderated by a thick edge. The presence of light is by its nature an expression of the everyday, we are deeply connected to the direction, colour and intensity of light as the sun rises and sets. These spaces alter this experience by changing these properties in unexpected ways. The mystical property of light is given precedent. The edges of contemporary sacred space become powerful moments for dividing and distinguishing the sacred and profane.

The sacred in contemporary culture can be closely associated with the emotional content of the numinous. The experience of a profound sense of otherness becomes a defining element of the sacred. It manifests itself in the sense of filtering, as edges are used to transition light, movement, and experience from the profane to the sacred. Understanding the role of edges in expressing the numinous reveals contemporary sacred space as one shaped by filtering and exclusion, informed by, but at the same time separate and distinct from, the quotidian.

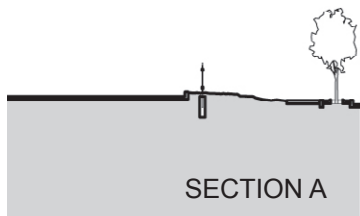
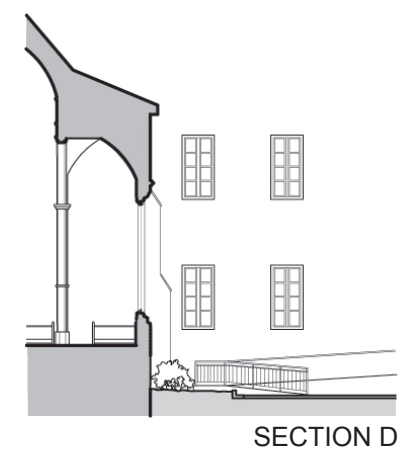
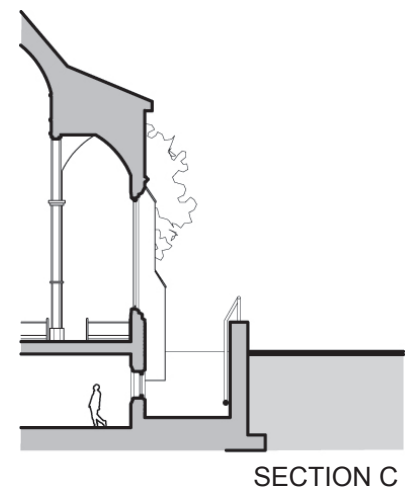

figure 1.11
Sections across St. Basil's Church
investigate the architectural element
of the edge



vii. The Edge

THE ARCHITECTURAL ELEMENT of the edge in contemporary sacred space acts to reinforce the division between the qualities and realities of the 'in' and 'out'. The effect is to generate a border between sacred and quotidian space. Edges act to exclude and separate that which is deemed not important to the internal or external reality. In this manner, the numinous becomes an abstract, personal experience of the sacred, distinct from the rest of the world. There are several methods however, of expressing the border. While each presents a different relationship between the sacred and quotidian, in each case the effect of the edge is to separate and distinguish between the two.

As Stephen Holl's Chapel of St. Ignatius illustrates, one of the clearest methods of generating the edge is by defining a strict border which filters and excludes. The sacred becomes the wholly other. It is a mystical experience of leaving the quotidian and entering the divine. Exterior relationships to the physical being of the world are masked, blurred or reinterpreted to overlay a supernatural reality. These moments become internalized experiences of the mystical in an effort to construct a phenomenological experience of the other.

figure 1.12

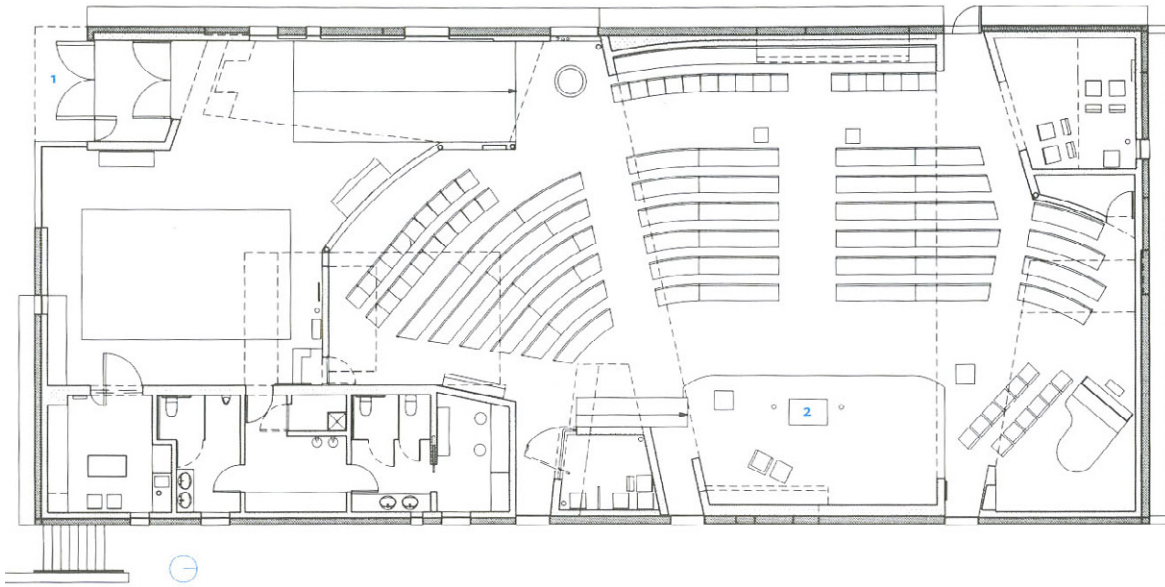

figure 1.12 Plan of Chapel of St. Ignatius, Stephen Holl Architects. Interior of chapel (bottom left), view of entrance (bottom right)

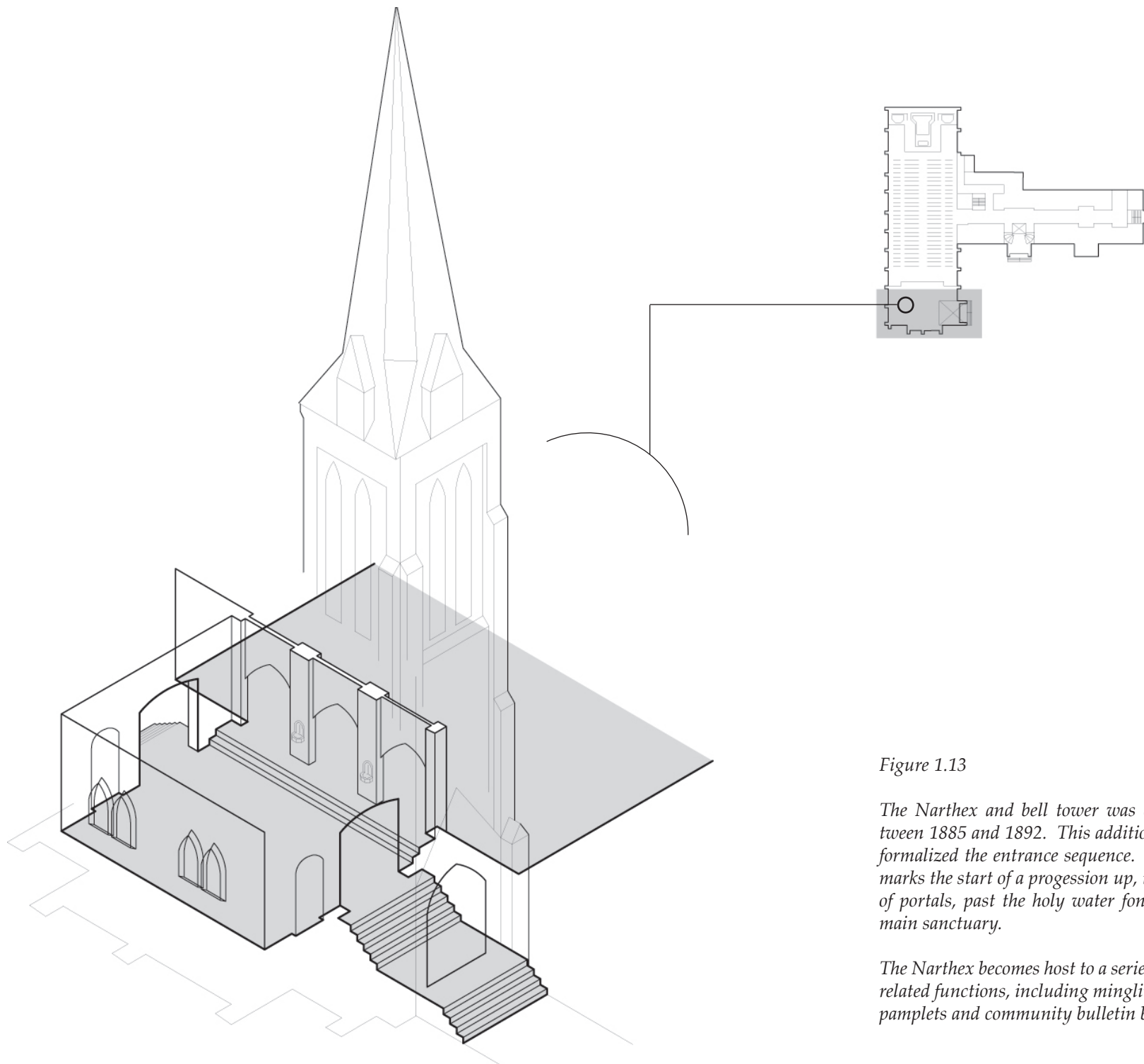
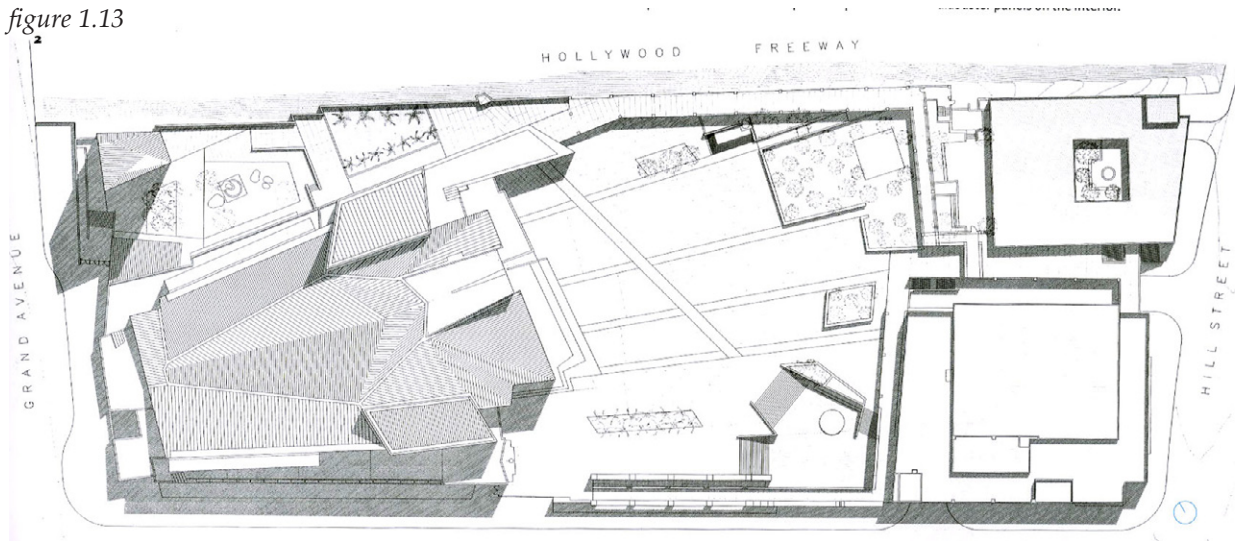

Figure 1.13

The Narthex and bell tower was constructed between 1885 and 1892. This addition to the church formalized the entrance sequence. The Bell tower, marks the start of a progression up, through a series of portals, past the holy water fountains and into the main sanctuary.

The Narthex becomes host to a series of community related functions, including mingling, information pamphlets and community bulletin boards.

figure 1.13



Thresholds become abrupt; one is either in the sacred or the profane. Within the sacred, the edge reinterprets elements which pass through, rendering them as supernatural elements. Light, sound and movement acquire new meanings wholly separate from their being on the outside. The edge condition of such sacred spaces creates a dichotomous relationship between the sacred and quotidian.

Often however, edges are not nearly so clearly defined. In the case of Rafael Moneo's Cathedral of Our Lady of the Angels, a generous amount of community gathering space is provided. The entrance and exit to the church participates in a ritualized movement through a courtyard, which acts as a mediator to the street. This space is analogous to an extremely generous narthex or lobby. The architectonic expression is one of balance between a sacred space and a community space. However, the community space is only a representation of the quotidian beyond. The quotidian world is provided an analogous semi-sacred field in which the sacred is placed. The relationship between the courtyard and the street is strictly defined by a stone wall. The site gives space over to both the sacred and a limited version of the quotidian. Two sets of thresholds, one between the site and the world, the other between the



figure 1.14. Siteplan, Cathedral of Our Lady of the Angels, Rafael Moneo. Exterior view from street (bottom left), cathedral interior (bottom right)

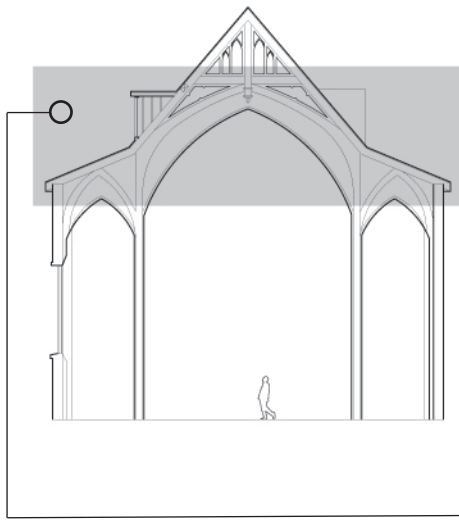

figure 1.15

In 1965 the previously exposed ceiling beams were enclosed. The light from the dormer windows was blocked off, although the roof remained largely unchanged (minor repairs).

The new plaster ceiling helped to lower building maintenance costs by easing the heating load. It also generated a significant volume of space between the existing roof and new ceiling.

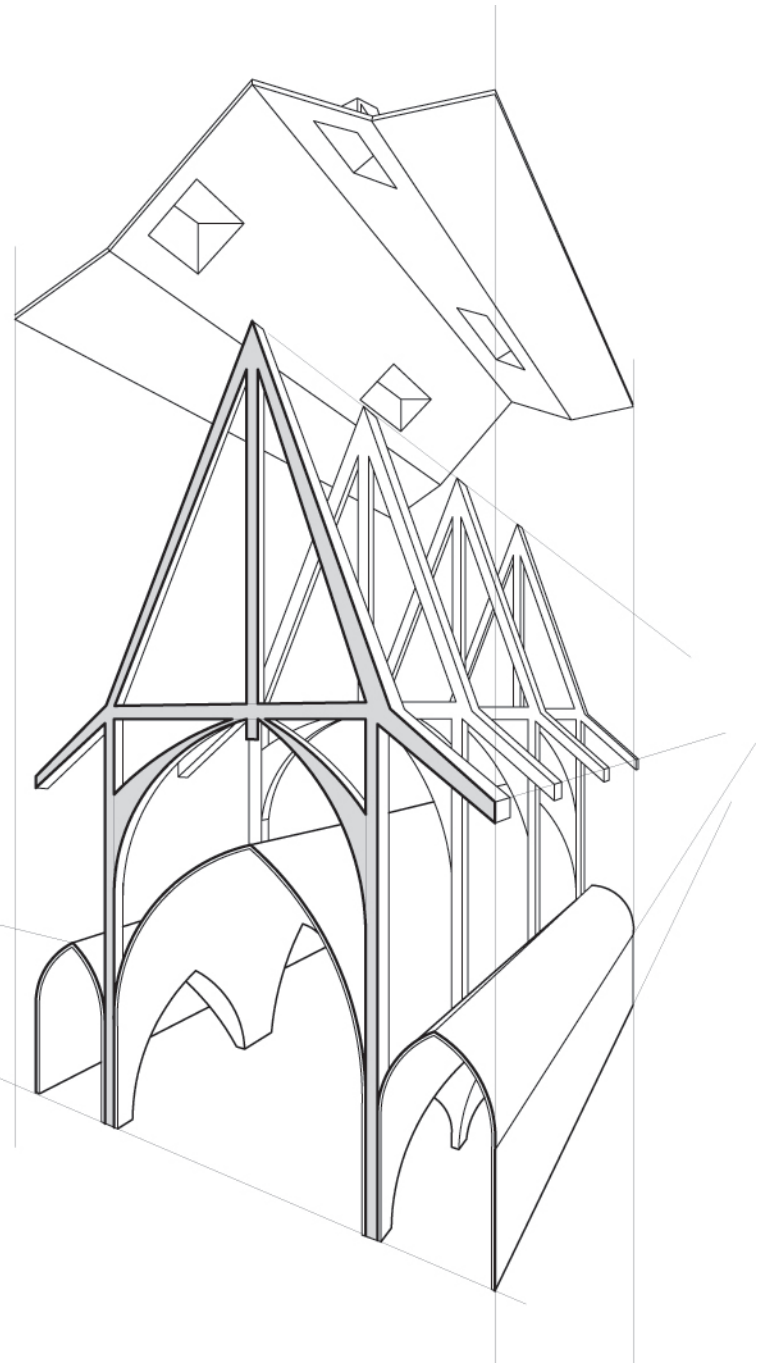
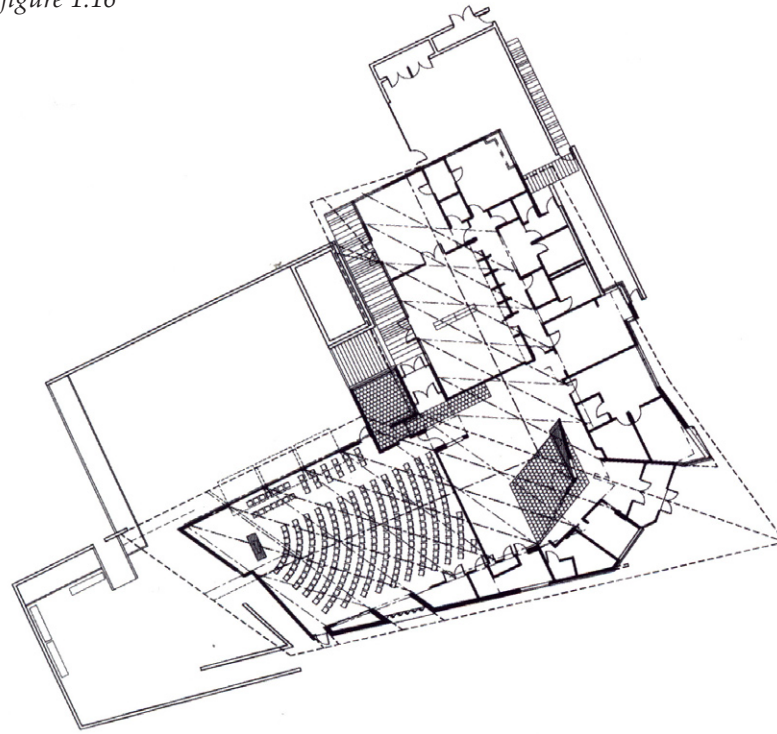

figure 1.16



sacred and the site, act independently. While the latter may act to overlay meaning, the former is a line individualizing the site. The edge condition becomes a hierarchical one which defines a sacred space, a 'controlled' quotidian, and everyday world beyond.

Increasingly, we are also seeing sacred space spontaneously generated in quotidian space through sociological demarcation where sacred architecture is almost non-existent. This is the rather recent phenomena of mega-churches in auditoria, stadiums, malls and theatres where the sacredness is temporarily created by the event. Stephen Teeple's Church of the Incarnation produces an entirely flexible plan. Sacred space can be quickly changed into several forms, which the architecture equally supports. A homogeneity of sacred and quotidian space leads to an equivalency, where every space has the possibility for sacrality. Through social convention or assigned function a space can acquire sacredness. There is no transition required as all space is freely open to its surrounding influences. Thresholds become thin or unnecessary in an attempt to eliminate any division. This lack of edge allows cultural, political or economic forces to enter freely, resulting in typologies more similar to community centres, or shopping malls. The result is an edge which exists in

figure 1.15 Plan of the Church of the Incarnation, Stephen Teeple Architects. Interior view from movable altar (bottom left), view from the narthex to the sanctuary (bottom right)



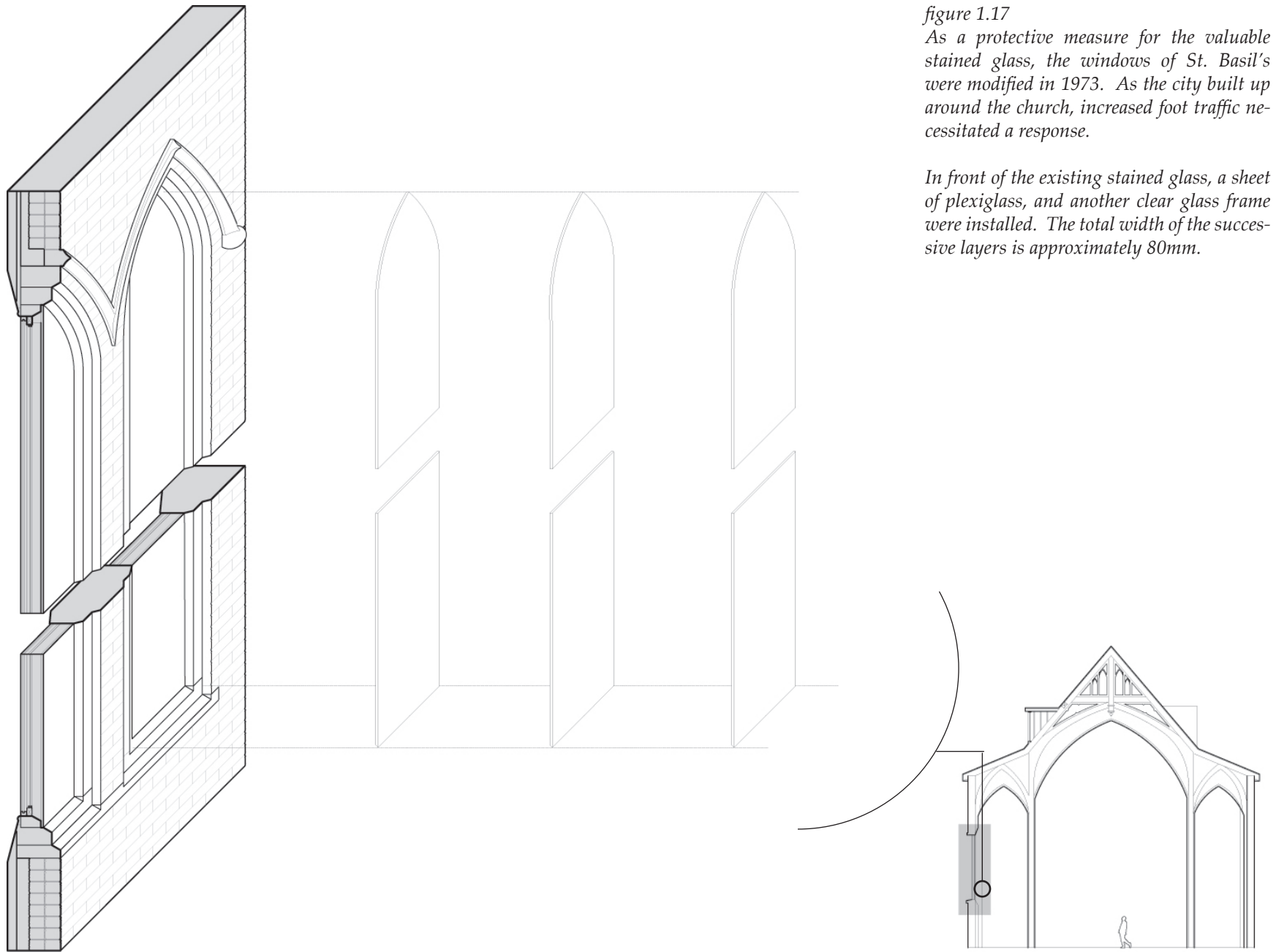

figure 1.17
As a protective measure for the valuable stained glass, the windows of St. Basil's were modified in 1973. As the city built up around the church, increased foot traffic necessitated a response.

In front of the existing stained glass, a sheet of plexiglass, and another clear glass frame were installed. The total width of the successive layers is approximately 80mm.

the social agreement. One either participates in the community and recognizes the sacred or does not. There is no architectonic expression of the relationship between sacred and everyday. The edge condition becomes a nihilistic one which defines space as a technical reality, and the sacred as a social convention.

The role of the edge in shaping contemporary sacred space is a powerful one. Architectural expressions of a divide between the sacred and quotidian express an understanding of the numinous which is abstract and subjective. The qualities of the ineffable become the dominant expression of the sacred. This results in a sacred which becomes relativistic, cut off from the world and only concerned with personal experience. This is a problematic condition for sacred architecture. Architecture treated as abstract personal vision lacks a communicative role. Sacred space requires an architectonic language which overcomes the subjective in order to incorporate qualities of memory, identity and belief. The contemporary architectural treatment of the edge diminishes the ability of sacred space to express social, political, and cultural narratives. Sacred space fundamentally requires a threshold across the border to the quotidian as it participates in the pursuit of meaning.

figure 1.18

A ramp was constructed to the basement beneath St. Basils church in 1973 connecting the parking lot to the church basement. The ramp not only improves accessibility to the lower level, but provides direct access for the church hall and its related community functions.

The church hall hosts a variety of service programs including an "Out of the Cold" program providing food and overnight shelter, as well as a "Food Bank"

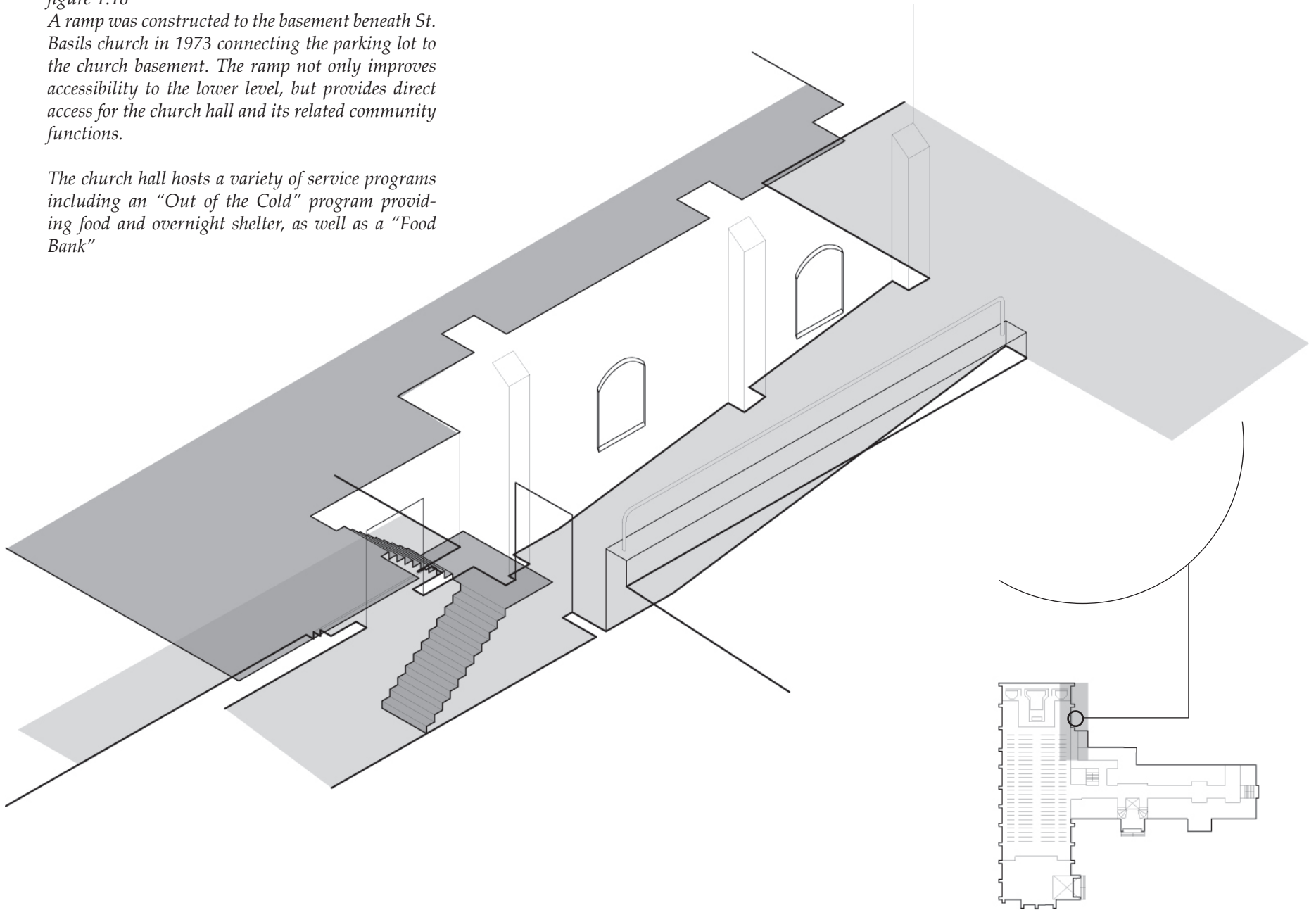

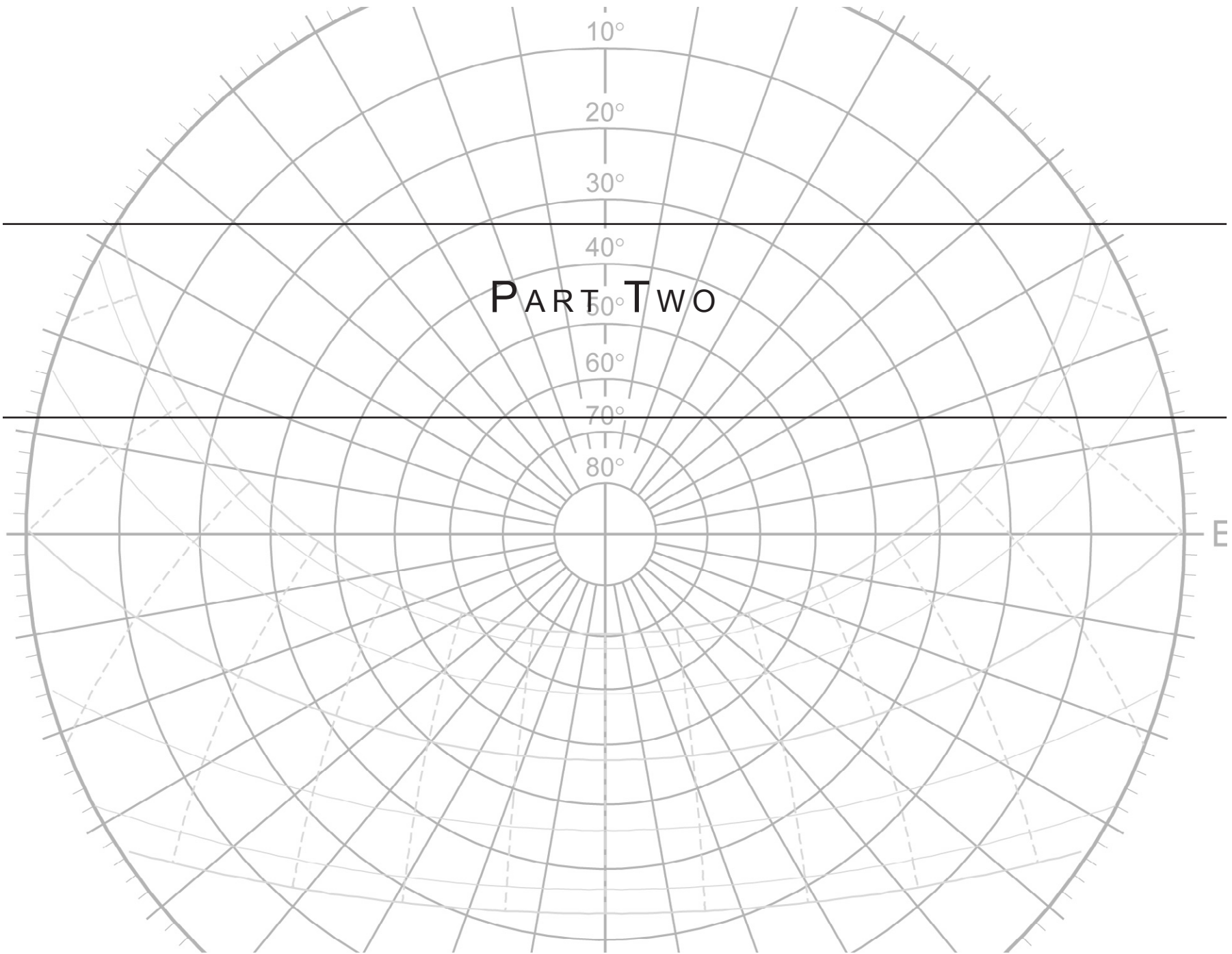

mortal; the quotidian

The mortals are the human beings. They are called mortals because they can die. To die means to be capable of death as death. Only man dies, and indeed continually, as long as he remains on earth, under the sky, before the divinities. When we speak of mortals, we are already thinking of the other three along with them, but we give no thought to the simple oneness of the four.

The Wedding at Cana

Jn 2:1

¹*On the third day there was a wedding in Cana in Galilee, and the mother of Jesus was there.*

²*Jesus and his disciples were also invited to the wedding.* ³*When the wine ran short, the mother of Jesus said to him, 'They have no wine'*

⁴*Jesus said to her 'woman, how does your concern affect me? My hour has not yet come.'* ⁵*His mother said to the servers, 'do whatever he tells you'...*

⁹*And when the headwaiter tasted the water that had become wine, without knowing where it came from...the headwaiter called the bridegroom* ¹⁰*and said to him, 'Everyone serves good wine first, and then when people have drunk freely, an inferior one; but you have kept the good wine until now.'*

-Jn 2:1-10

THE NARRATIVE OF the wedding at Cana is unique to the Johannine gospel. Immediately following the revelation of Jesus' messianic identity by John the Baptist, the gospel of John depicts seven scenes which assert the mission of Christ. The wedding at Cana is the first of these, and represents the first miracle of Jesus in the Johannine account. Jesus is depicted as a wedding guest who secretly replenishes exhausted wine supplies by converting water in several jugs. It is notable in its apprehensive and cautious display of Jesus' supernatural abilities. The reluctance to display power and the commonplace nature of this first miracle stand in contrast to the other miracles in the gospel.

There are several aspects to this first miracle which emphasize its sacred intention and link it to the themes of the other miracles depicted. In the first sentence the gospel writer has emphasized the "third day", a divine numerology which may denote a sacred act.¹ The jars filled with water turned to wine are the ritual purification jars used in Jewish tradition for cleansing. The act of refilling them suggests a replacement of the source of purification. New wine is often used as a metaphor for Christ, and the act of replacing a traditional Jewish rite with an allusion to Christ is consistent with John's gospel. Jesus also refers to his "hour," foreshadowing the passion.²

What differentiates this passage from the rest of the miracles within the gospel are the elements which suggest apprehension, and the quotidian nature of the miracle. When confronted by Mary, Jesus' reply is ambiguous: "how does your concern affect me?" This phrase is more directly translated as "what to me and to you, woman" and could represent the Hebrew expression "ma-li walak", which does carry "overtones of refusal, or at least unwillingness to get involved³". The gospel writer has evoked a sense of reluctance in this first miracle.

Moreover all of the signs of sacred power are left cryptic and unexplained. Jesus' reference to the 'hour' is completely unintelligible without prior knowledge of the death and resurrection. His actions remain anonymous to the wedding guests, and no teaching or parable follows to explain the significance of the act. The purpose of converting water to wine, however miraculous, is not used as a sign, but fulfills the mundane need of a wedding celebration.

The author of the gospel has depicted the first sign of power by Jesus not in divine glory, confidence, or power. The sacred is reluctantly introduced, cautiously and anonymously into a quotidian place. There seems to be an implicit recognition of the challenge in introducing the sacred into the quotidian which foreshadows the eventual rejection and crucifixion in John's gospel.

Reflection

It is the mundanity of this miracle which captures my imagination. It is supernatural and yet outwardly ordinary. What should be a trumpeting sign from God is hidden.

I wander down the avenues and boulevards of the city, a plurality of cultures, ideas, and beliefs. The street however, with its endless squares of concrete and walls of glass, remains neutral. It is cleansed of the possible significance of 'meaning' or 'purpose' in order to preserve neutrality over these vague terms.

I identify with Jesus in this passage, hesitant and unsure about the role of the divine in the everyday. Does God really have a place here? What role does faith play in informing my actions? I speak with trepidation, wondering whether the expression of my self impedes the expression of another, wondering if it's my place to let God into the everyday. The miraculous appearance of wine seems to the world only a pleasant surprise. It is not explained, revealed, or repeated. It remains an anonymous and private miracle. I find no place to let the richness of my personal wonder enter the forum of the quotidian.

What is the nature of the quotidian and what role does my spiritual self play in this shared forum? Is it possible to express my faith in the secular city?

iv. defining the quotidian

THE QUOTIDIAN IS the space of mortals; it lives and dies with us, changing with the seasons, the built fabric which fills our life. Since the advent of secularism in western culture it has been possible to conceive of a time outside sacred time – a quotidian space and time. Christian sacred time orients an individual and culture within a temporal structure wherein position and direction are defined towards messianic fulfillment. Exterior to this structure is the everyday experience of the secular. The secular denotes the experience of a contrasting temporal framework, one which is measured not by a narrative of past present and future, but by a focus on the time of the ‘now’. The time of the quotidian is not tied up in the fulfillment of a divine meaning, but stretches infinitely into the past or future through individual moments. Quotidian space therefore, is the space of the secular.

Cities, streets and public spaces are often referred to as ‘secular’ spaces. The concept of secularism has become a central issue in defining the everyday spaces of our lives, as opposed to private ‘sacred’ spaces. The *Bouchard-Taylor Commission* (2008) explored the cultural practices of secularism⁴ in the Canada’s culture and its Charter of Rights and Freedoms as “a straightforward, unequivocal principle that prescribes the separation of Church and State, State neutrality and, by extension, the confinement of religious practice to the private sphere.”⁵ The space of the secular is understood as the public and shared space of the city. As the report suggests, however, the idea of the public has multiple meanings: “The first meaning of public, a legacy of Roman antiquity, concerns society overall in contrast with what affects private citizens.”⁶ What is defined as public in this sense are the institutions and forces which serve society. Another meaning of ‘public’ “originated in the 18th century: it refers to as public what is open, transparent and accessible, as opposed to what is secret or of limited access.”⁷ Under this definition, anything that is available to everyone is considered public. It is by this second definition that secular space is often understood as the absence of all sacred artifacts or reference from the shared space of the city.

Parking lots, sidewalks, streets, and public places are all considered to be secular spaces (figure 2.1). There is the perception that in these spaces the sacred is not present. However as Taylor explores in his book *The Secular Age*, the experience of the absence of belief is difficult to define. Taylor chooses to look at secularity in three ways: (1) a type

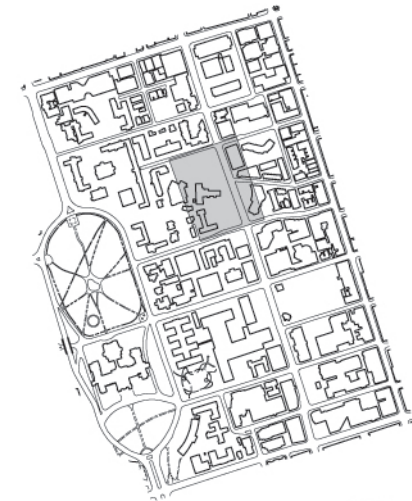

1. St. Basils Church
2. Odette Hall
3. Parking Lot
4. Public Square
5. Parking Booth
6. Condo Tower
7. Bay St.
8. St. Mary St.
9. St. Joseph St.
10. Entrance to St. Basil's
11. Office Tower
12. Sorbara Hall

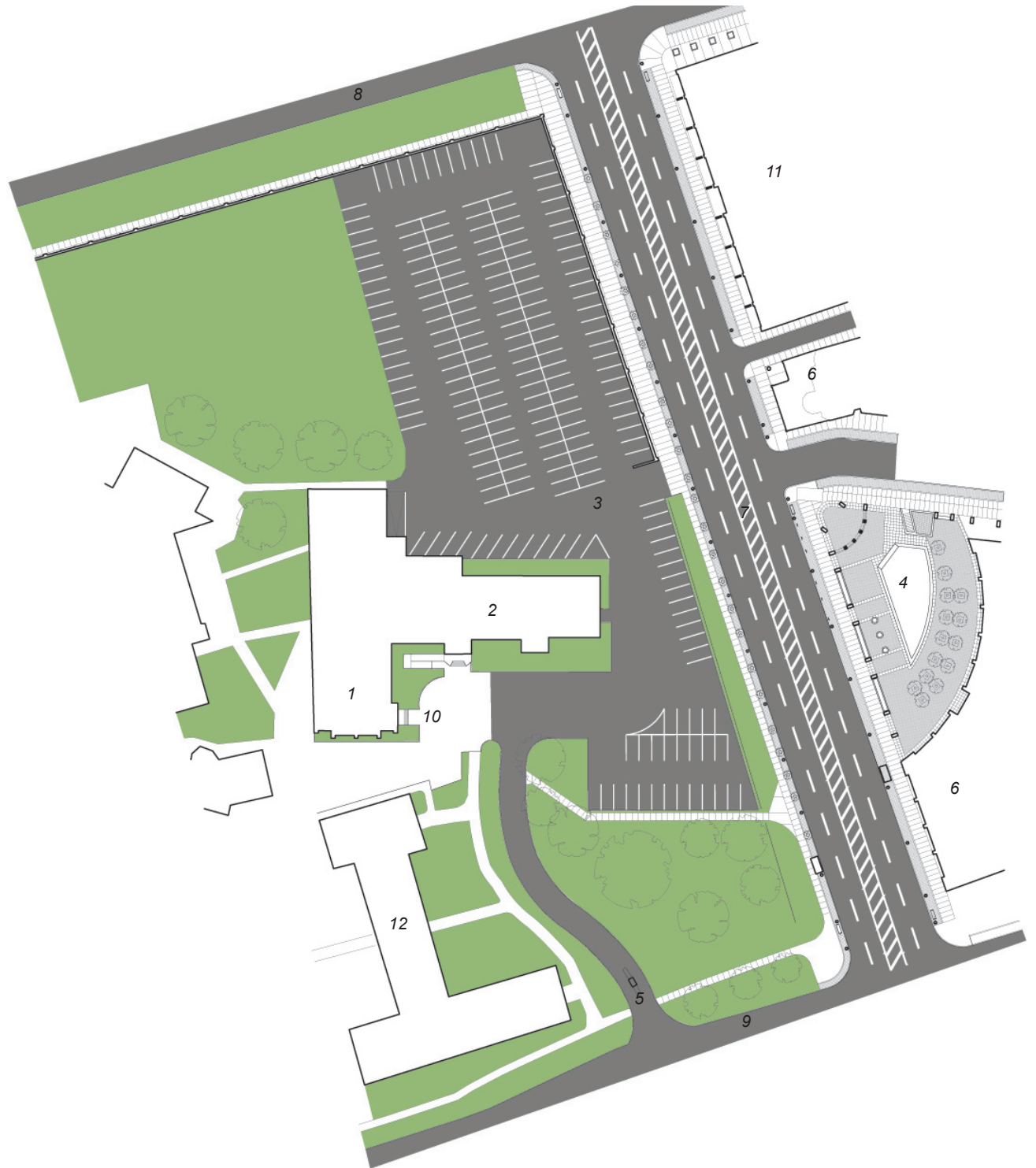

figure 2.1

We typically associate the secular city with any space that is available to everybody. The streets, public spaces, sidewalks are the everyday spaces of our lives.

The property surrounding St. Basil's church along Bay St. is one of the last remaining open sites along Bay St. and is the largest. Surrounding this parking lot and unused green space are sidewalks, Bay St. and a public square to the east.

of belief and practice which is retreating in public space; (2) a type of belief and practice which is in regression; (3) a type of belief and practice whose conditions in this age are being examined. Taylor reveals that secularity understood in terms of definitions (1) & (2) is often difficult to track. Public expressions of belief and practice flourish in new and different ways. Moreover, the task of measuring belief by church attendance is problematic as it doesn't actually demonstrate the presence or lack of belief. Is it really possible to measure the levels of belief along our sidewalks and public spaces? Taylor instead examines the conditions of belief in the contemporary age which are undergoing change. The focus of Taylor's analysis is that the contemporary age is unique in its lack of uniformity of belief, and the awareness and freedom of the possibility of a multitude of beliefs (including no beliefs at all)⁸. The space of the secular is one whose structures present this freedom and unlimited possibility.

This understanding of secular space is deeply entwined with the notion of time. The Latin root of the term secular *saecularis*, denotes the time of an age or generation. A *saeculum* was a unit of time measured from an historic moment until the point in time that all people who had lived at that moment had died. Early Roman culture believed that each civilization was allotted a specific number of saeculum. The term is similar to the contemporary notion of a generation which has specific characteristics and is defined by cultural events such as "Gen-X" or "Gen-Y". It is related to experience and measured in terms of human existence. Generations are not measured by the progression along a meta-narrative but by the changing nature of experience. Human lifespans are used as a reference point as opposed to a divine plan.

The measurement of time through the reference to human lifespans uses a different unit of measurement. Christian sacred time places humanity in a middle time, after the fall from grace and before the eventual return. Secular time is defined according to human time and stretches forwards and backwards measured in intervals of seconds, minutes, hours, days, or years. The experiences and moments which occupy these intervals define their passage. Secular time is therefore quotidian in nature. The quotidian is concerned with the passage of these measured units of time. Quotidian time presents an absolute freedom of possibility. Time is not working its way from a past destination towards a future one. The measurement of time in equivalent units of seconds, minutes, hours or days allows an infinite sequence of experiences. Taylor's understanding of the secular, as a freedom of

possibility of belief, is preserved in a temporal understanding of the secular. Quotidian time is our time, and its space is the space of the everyday, the shared ground of the city.

Quotidian space can be considered the fabric that wraps around and joins the various defined spaces of the city: streets, parking lots, sidewalks, other left over spaces. Its edges are blurry, formed by property lines, building faces, and perceptions of control. It stretches beyond these insofar as we feel shared access and ownership. The shared ground of the city is a space uniquely oriented to us. The saeculum, the time of our experiences, is the time of which the city beats. This temporal narrative is not necessarily a program for a built project, but is concerned with a "civic aesthetic", an expression of shared ground into which the functions and places of a city are placed. The city is the shared ground between the host of private residential, commercial, cultural or religious structures which inhabit it. This shared ground is the space of interaction, the space between individuals. It is an expression of our culture and identity as a larger community, as it hosts our daily interactions and negotiations, and its structures reflect the time of the quotidian.

The space of the quotidian is not structured by a larger temporal framework as in sacred space. It is the space of 'our time', open to the innumerable possibilities which make up the saeculum. Time is not given a direction or destination; the quotidian provides space for everyday moments. The space of the quotidian preserves this sensation of possibility in its relation to time. Time passes equivalently over the city in a daily, weekly, and yearly schedule. There is an infinite possibility of experience within the quotidian which reflects the cultural possibilities of a secular age.

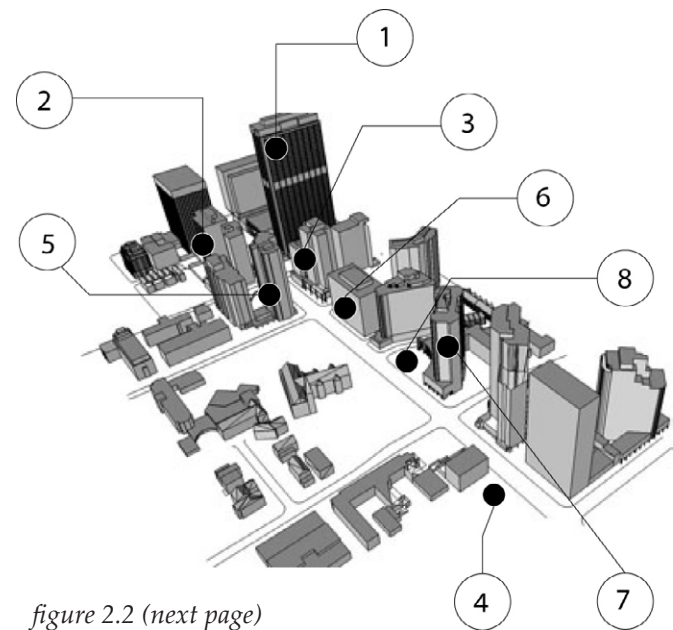

figure 2.2 (next page)

The quotidian is the space of the 'now' Its temporal zone is the moment. The shared ground of the city is the one which exists in this quotidian time.

Photographs of Bay St. through the course of one day reveal the architectural experience of the quotidian.

1



2



3



4



5



6



7



8



9



SUNRISE 0653

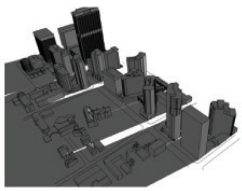

f5.6 1/200
ISO 400

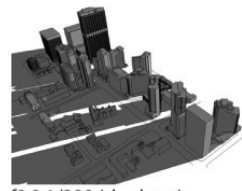

f8.0 1/200 (shadows)
1/1000 (highlights)
ISO 400

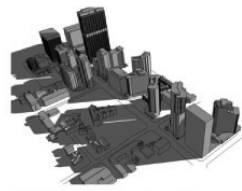

f8.0 1/400 (shadows)
1/1600 (highlights)
ISO 400

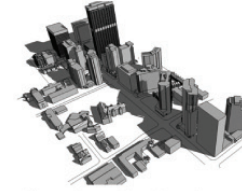
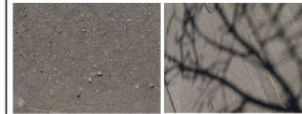
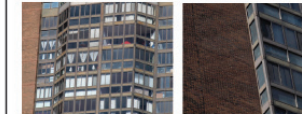

f8.0 1/400 (shadows)
1/1600 (highlights)
ISO 400

0700

0800

0900

1000

1100

1200

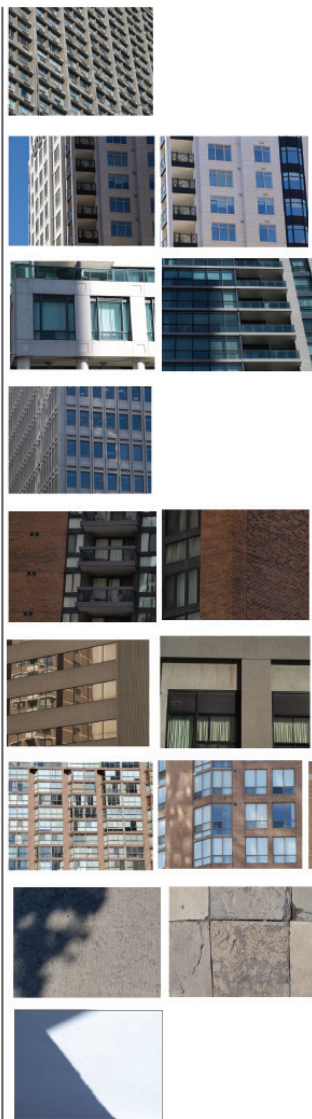

f8.0 1/400 (shadows)
1/1600 (highlights)
ISO 400

1300

1400

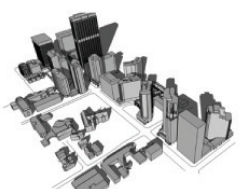
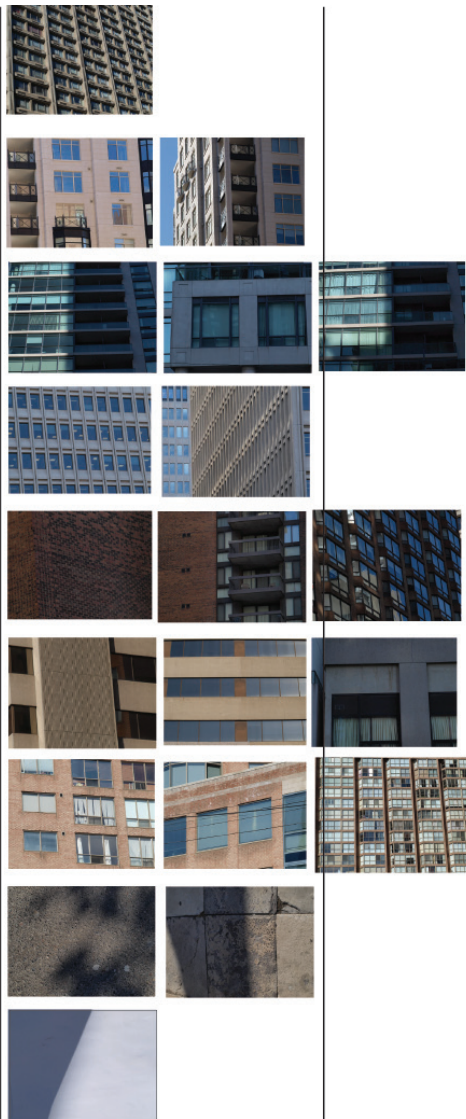

f8.0 1/400 (shadows)
1/1600 (highlights)
ISO 400

1500

1600

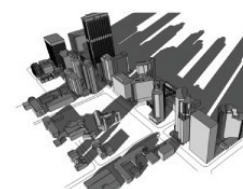
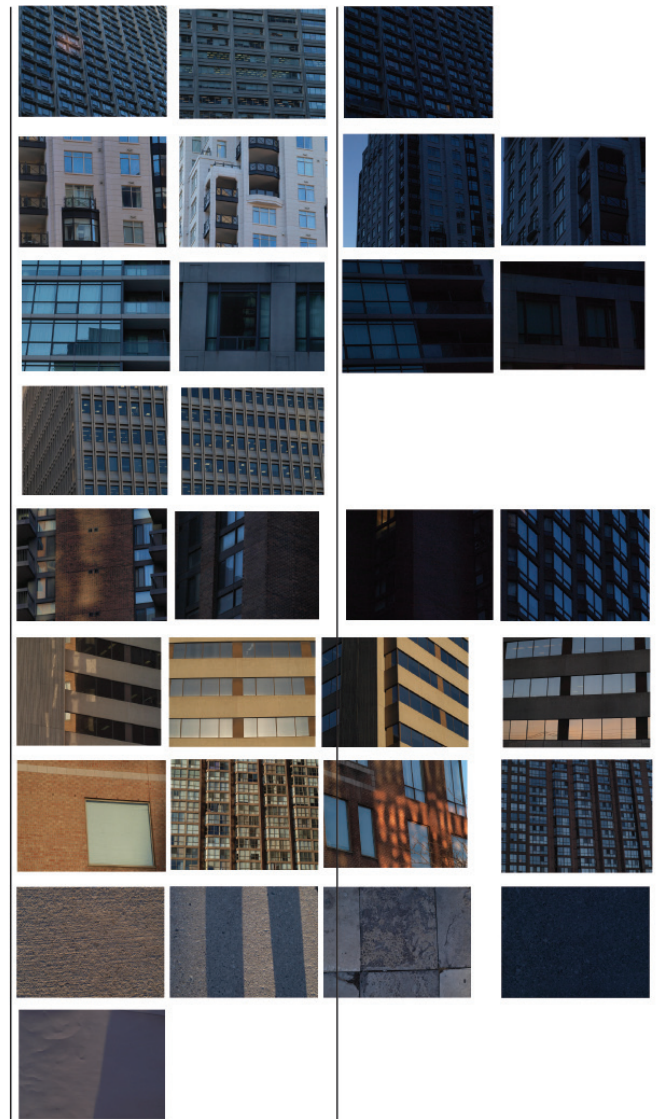

f8.0 1/400 (shadows)
1/1600 (highlights)
ISO 400

1700

1800

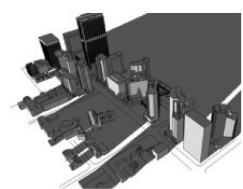

f8.0 1/200 (shadows)
1/1000 (highlights)
ISO 400

SUNSET 1808

iv. The Experience of the Quotidian

AS TAYLOR'S EXPLORATION of our secular age reveals, the secular can best be defined as a contemporary condition of varied possibility. The quotidian is the space of this possibility. Its time is rooted in experience: the time of the 'now'. Reading and experiencing quotidian space therefore involves the act of recognizing this experiential quality which is ever changing – it is a temporal act. By passing through the streets, parking lots, and in-between places of the city we experience the quotidian.

Walter Benjamin's book *The Arcades Project* illustrates how a city can be experienced in time. This enormous encyclopedia of thoughts and observations comes out of Benjamin's wanderings through the arcades of 19th Century Paris. Critical to Benjamin's work is the concept of the 'flaneur'⁹: the individual who strolls through the city experiencing and observing. *The Arcades Project* captures the temporal experience of space. An 'arcade' is a covered pedestrian street which became a dense commercial typology of the Parisian urban plan. The bustling, shifting and chaotic life of the Arcades of Paris cannot be captured in their static form or orientation. The life of the arcades relies on the experience of sellers, wares, movement, and sound to capture its spatial qualities.

In these ever changing streets of the city, Benjamin sought to read the collective culture. As a common ground, Benjamin saw the arcades as a sign of his contemporary age:

*"Streets are the dwelling place of the collective. The collective is an eternally wakeful, eternally agitated being that – in the space between the building fronts – lives, experiences, understands, and invents as much as individuals do within the privacy of their own four walls.More than anywhere else, the street reveals itself in the arcade as the furnished and familiar interior of the masses."*¹⁰

The Arcades Project uncovers the richness present in the quotidian. As an expression of a collective consciousness, Benjamin explores how much can be discovered about a culture through the built environment. The arcade became the architectural form through which Benjamin observes the common ground of an age.

The quotidian space of our contemporary cities similarly reveals our common ground. How the varied possibilities of the secular are sustained through the architecture

figure 2.3 (opposite page) Movement along Bay St.





*figure 2.4.
Efficiency of access is provided by zones of movement*

*figure 2.5 (opposite page)
The rhythm of Bay St. propagates with regular dimension and spacing.*

of the quotidian reveals the character of the contemporary. Moving through the streets, sidewalks and public squares of a city reveals the nature of our saeculum.

The contemporary city, unlike the arcades of Paris, can be passed through at a wider variety of speeds. Automobiles, bicycles, and walkers all experience the quotidian in a unique temporal relationship. Scale, immediacy, and experience all vary according to the rate of movement and passage of time. Movement along Bay Street in the city of Toronto is divided according to these speeds, providing zones of movement. Changes in paving type and height are indicators of these different zones. These changes provide an efficiency of movement allowing equal access to the variety of addresses.

The possibility of address along Bay Street can be extended infinitely. Tower after tower line the street. Similarly, paving stones, doorways, streetlights, fire hydrants, trees, and newspaper stands propagate with a regular and equivalent rhythm. There is an infinite possibility of location along Bay St.

This repeatability results in an indeterminacy to the experience of the quotidian. The repetition of elements makes differentiation difficult, as one stretch of



figure 2.6 (opposite page)

Repeatability causes an indeterminacy. Structural bays are occupied (or not) by any number of possibilities. Signage helps to differentiate one bay from another.

figure 2.7 (next page - left)

An indeterminacy relies on signage to indicate its content. Instructions must be given in order to differentiate use and purpose

figure 2.8. (next page - right)

Materials come in standard dimensions, reproduced mechanically in preset combinations, meshion and spacing.

paving is similar to another. The walls of the street similarly possess an indeterminacy. The six foot structural bays of towers¹¹ can be inhabited by storefronts, offices, lobbies, or residences. One bay is identical in size and dimension to another. Signage identifies a store which invites entrance, and an office which discourages it. Qualities of overlook, privacy, or openness are all dealt with by expanses of glass curtainwall¹² which forms a standard material palate for the variety of inhabitation along Bay Street.

These materials come in standard dimensions creating a sense of repetition and modularity. Concrete sidewalk pavers are poured in standard sizes, storefront entrances are chosen from a list of possible dimensions, and precast concrete panels have ideal layouts. Dimensions and sizes are determined by the combination of parts. The pieces are interchangeable and allow an ease of assembly. The space of Bay St. contains a regular set of modules composed of steel, glass, brick and concrete which repeat in regular patterns.

These experiences of equivalent access, an infinite extension, an indeterminacy and a modularity all maintain the common ground of the quotidian. Analyzed in a static condition, each element of Bay Street is a individual location; a condominium,









figure 2.9
Modular parts mean that dimensions are standardized for all building types.

figure 2.10 (opposite page)
The quotidian space of the city contains infinite possibility. Various functions can be inserted into its fabric all with equivalent access, and look.

bank, office or store. The act of moving along the street in time however, reveals a space of possibility. In motion one realizes that the locus of the individual space is not significant. The space of the quotidian is seen as an interchangeable sequence.

The common ground of the city provides the location for mixing between any number of possible elements. The infrastructure and layout of Bay St. allows for residential, commercial, retail, churches, institutions, and public services to occupy the space of the city. Charles Taylor's definition of a secular age as one which a uniformity of belief and maintains an awareness and freedom of possibility is manifested in the space of the quotidian. Our common ground, the space of the 'now,' is one which has an infinite possibility of inhabitation. The experience of the 'now' is one which permits freedom of options and access. Unlike the defined temporal structure of sacred space, the space of the quotidian is one which occupies the space of possible moments.



.vi Instrumental Space

THESE EXPERIENCES OF the quotidian reveal the architectural space of the secular in the contemporary city. The quotidian expresses both the freedom of possibility, and a simultaneous experience of indeterminacy, through the tools of the marketplace. The repetition, modularity and indeterminacy of the quotidian are results of the use of mechanical reproduction.

The effect of the marketplace on the quotidian is one which Benjamin was also interested in with his analysis of the arcades. Benjamin's exploration of the arcades was motivated by an interest in the commodification of things¹³. The shops of the arcades became a unique space of the modernizing city. The development of the arcades in the nineteenth century was a defining moment in the use of mechanical reproduction. Industrial processes began to impact every aspect of life, providing seemingly limitless opportunities.

As Taylor's exploration of the development of the secular points out, the nineteenth century was also important in the cultural understanding of the secular. "In the nineteenth

figure 2.11

Bay St. developed along with the city of Toronto in the 19th Century. Outside St. Basil's Church, the fabric of Bay St. has been repeatedly supplanted by newer buildings. A consistent demolition and enlargement of the urban fabric relies on the commodification of the space.



century, one might say, unbelief comes of age. It develops a solidity, and a depth, but also and perhaps above all, a variety, a complex of internal differences.”¹⁴ The focus on the mechanical and the material in the nineteenth century took on a central role in the discussion of God. Taylor’s exploration of the development of the secular, and Benjamin’s explorations on the space of the arcades, are related. The freedom of possibility which Taylor describes as coming of age in the nineteenth century is connected to Benjamin’s descriptions of the arcades.

The architectural expression of the secular and the possibilities of mechanical reproduction come together in the space of the quotidian. Mechanical reproduction is used to evoke possibility. The development of Bay Street. relies on mechanical processes for its growth and development (figure 2.11). The quotidian expresses an indeterminateness through the anonymity these processes allow.

The effects of technology on architectural practice and on the experience of our

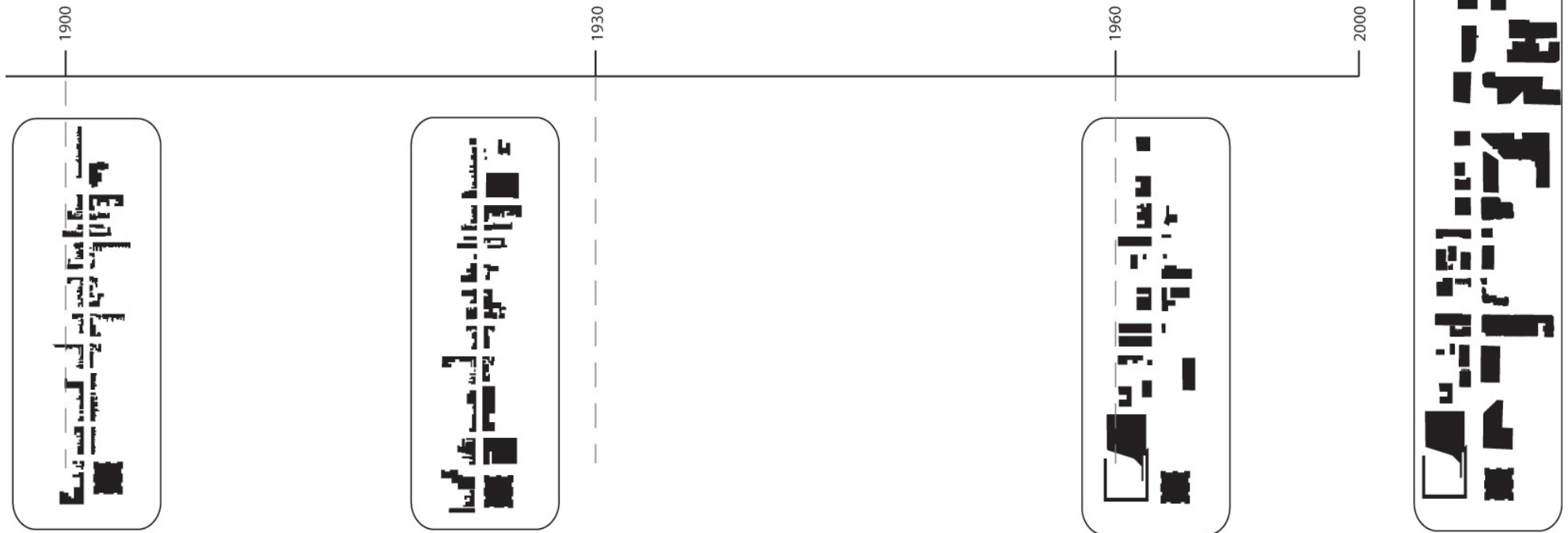

built environment is explored in *Architecture in the Age of Divided Representation* by the architectural historian Dalibor Vesely. He argues that the modern epistemology of science and technology results in instrumental space. Instrumental space is the product of architecture “as a discipline that can be treated as an instrument, or as a commodity.” He contrasts this to ‘communicative space’, space which enriches and participates in our relationships to each other and the world.¹⁵ As Vesely describes, instrumental space arose from the fragmentation of scientific knowledge and human experience, wherein the former was given to define reality, and the latter internal subjective sensation: “The loss of faith in the original meaning of pre-established harmony left behind no more than mathematical laws of reality, the promise of universal knowledge, and isolated perceptions.”¹⁶ The result is a modern pluralism which makes many forms of knowing which are not strictly scientific defined as personal and private. As a result, Vesely argues, architecture is therefore treated as a technical object, governed by economic imperatives.

Instrumental space is a problematic condition. Architecture treated as a commodity lacks the communicative role. Quotidian space fundamentally requires a sense of agency as it participates in the discussion of meaning. Indeed, Vesely’s thesis centres on trying to promote a new poetic of architecture which is ‘communicative’ as opposed to ‘instrumental.’ The communicative role of architecture is to “embody and found culture.”¹⁷ It acts as a “vehicle of participation, understanding and global meaning,”¹⁸ to shape the human experience. Constructing such an architecture means encouraging the expression of human desire within the built environment.

The writer and poet laureate of Toronto, Pier Giorgio DiCicco, echoes similar thoughts in his book *Municipal Mind: Manifestos for the Creative City*. DiCicco uses the term ‘creativity’ to describe the missing quality in instrumental space. His book is “a series of manifestos and reflections on what makes up the creative city. The situation is drastic and the truth startlingly rude. Cities are built by the market.”¹⁹ DiCicco understands the idea of ‘creativity’ as the expression and interaction of human desires. It is not that “imagination and commerce” cannot meet, but that the space of contemporary cities lacks the ability to express the human spirit. Shared ideals and vision, DiCicco argues, generates an engaging and meaningful built environment. For this reason narratives of memory, identity and belief (the architecture of the sacred) have a role in the creative city. DiCicco sees creativity as a bridge

figure 2.12
The dimensions and components of the streetface of Bay St.

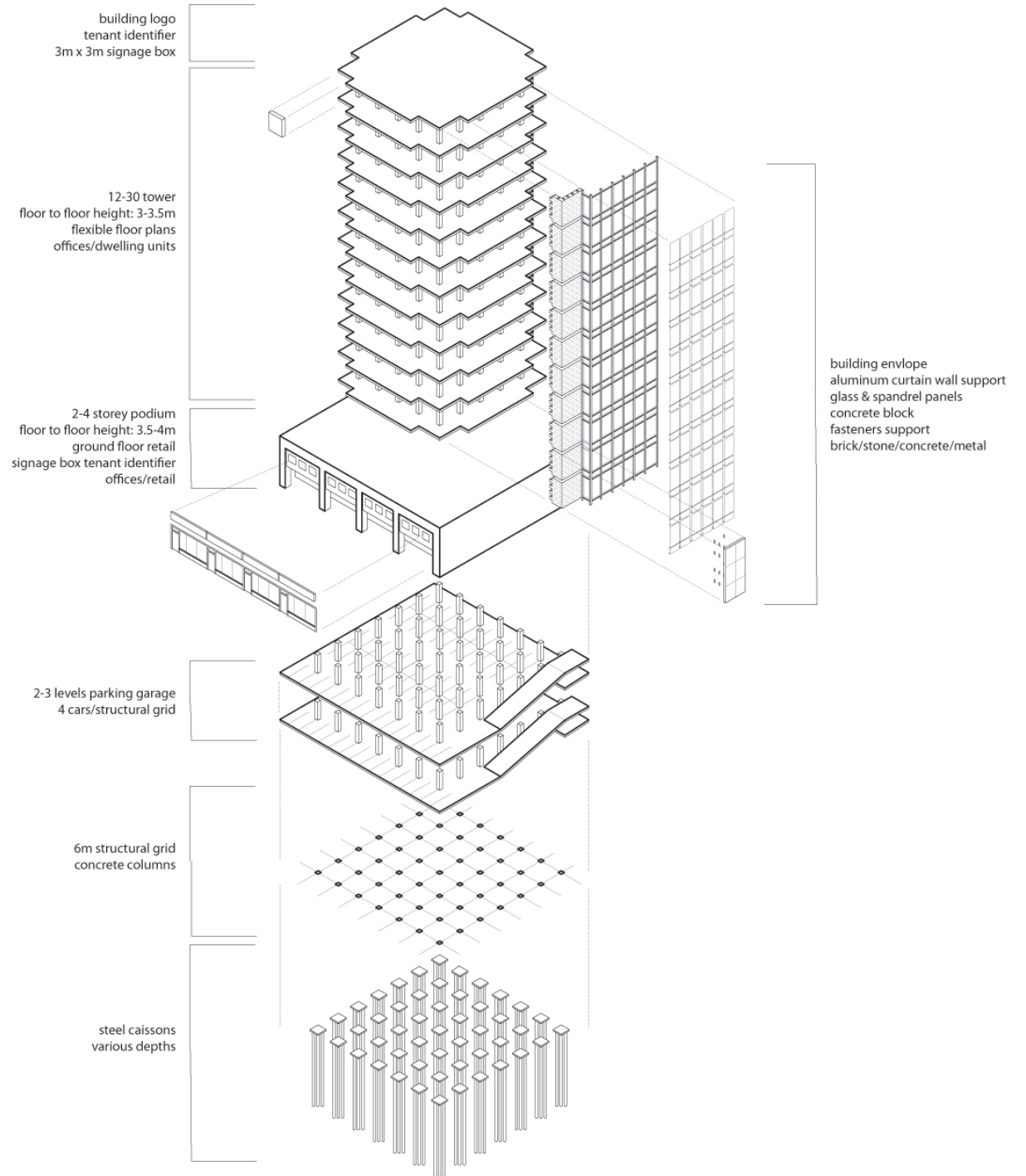

to these narratives: “If we are to come together as different peoples in a migratory age, we must share a common ethic. It cannot be religious, political, socio-cultural or ideological. In today’s diversity, such commonality is found only in creativity, common delight and shared imagination and wonder.”²⁰

What DiCicco calls ‘creativity,’ acts to bridge towards personal narratives (including the religious, political, socio-cultural or ideological) within the common ground of the quotidian.

The quotidian space of our cities is the space of ‘our time’. It captures the unique possibility of a secular age which is characterized by the historically unique condition of multiplicity of belief. In the expression of this experience, the mechanical has taken on the

figure 2.13
The dimensions and components of the streetspace of Bay St.

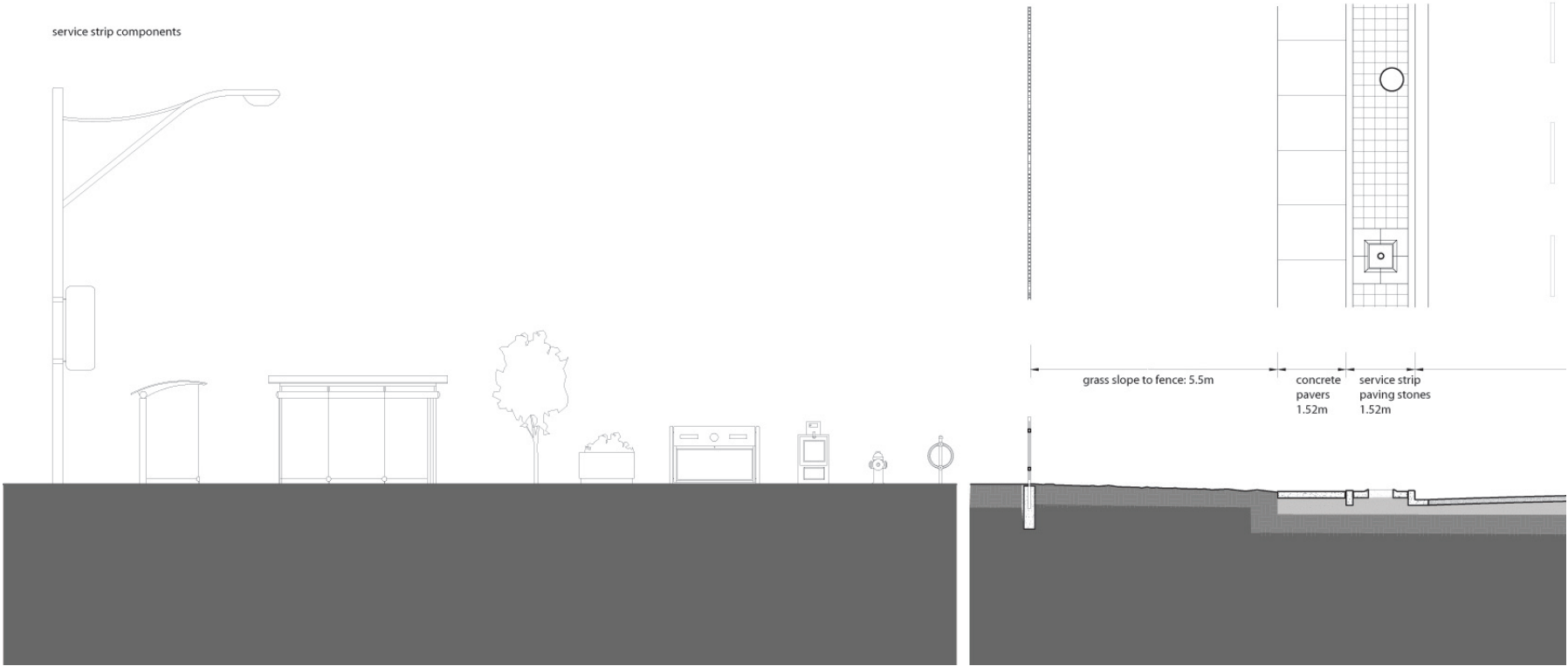

role of expressing this possibility. The experience of Bay St. is one which expresses equivalent access, an infinite extension, an indeterminacy and a modularity, all which emphasize the varied possibilities of the moment. The commercial-industrial processes of mechanical reproduction are one language of this expression. The result however, has been to limit the communicative function of space: the space of possibility has become a technical space which lacks an expression of a common ethic. DiCicco suggests that there exists a common ground through the idea of 'creativity'. The space of the secular must reach out to the personal, to incorporate, question, and encourage debate as a project of global meaning. The quotidian fundamentally requires a threshold into this private realm of the human spirit.

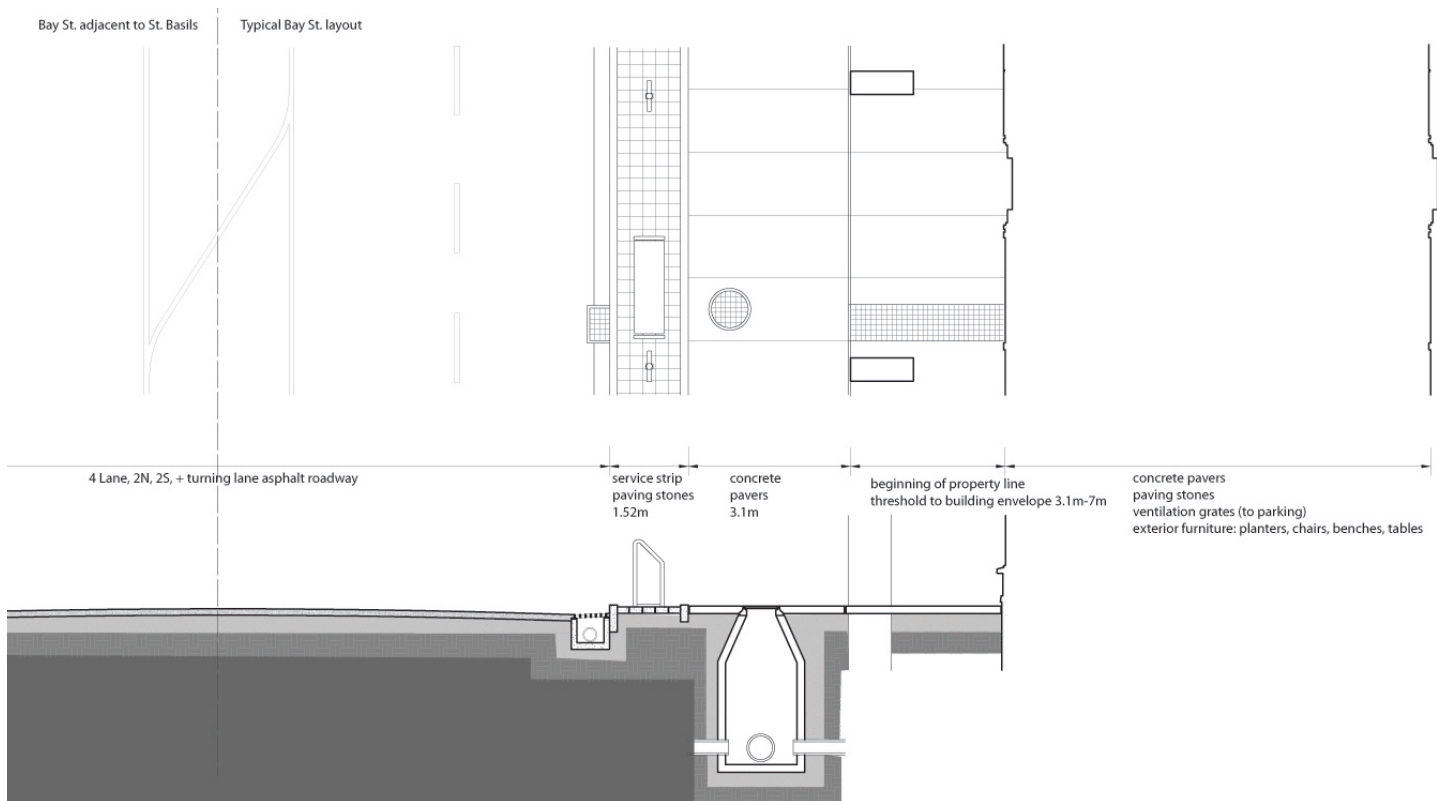

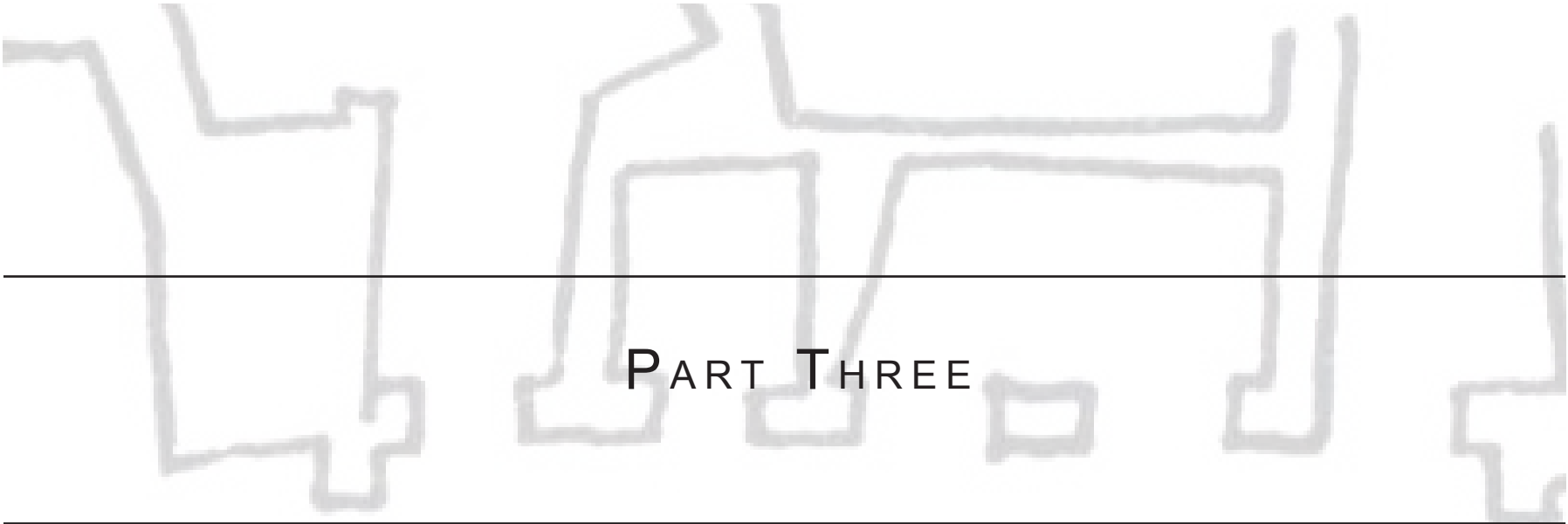

PART THREE



earth; the ineffable in the everyday

Earth is the serving bearer, blossoming and fruiting, spreading out in rock and water, rising up into plant and animal. When we say earth, we are already thinking of the other three along with it, but we give no thought to the simple oneness of the four.

§53 The Call of Levi

Mk 2:13, Lk 5:27, Mt 9:9

²⁷After this he went out and saw a tax collector named Levi, sitting at the tax booth; and he said to him, "Follow me." ²⁸And he got up, left everything, and followed him.

²⁹Then Levi gave a great banquet for him in his house; and there was a large crowd of tax collectors and others sitting at the table with them.

³⁰The Pharisees and their scribes were complaining to his disciples, saying, "Why do you eat and drink with tax collectors and sinners?"

-Luke 5:27-30

THIS PASSAGE, found in all three of the synoptic gospels, is fairly similar in both the recounting and placement. Its context is within several criticisms of the Pharisees which both precede and follow it. Central to this passage is the conflict between what is defined as sacred, and those activities which fall outside the sacred.

The Pharisees were a group attempting to reassemble the variety of splinter groups through a renewed adherence to the laws of the Torah. Throughout the gospels, especially Luke, the Pharisees are portrayed in a negative manner, and Jesus routinely comes into conflict with them.

The term for sinner used in these passages (*hamartoloi*) would have been for persons “whose occupation or life-style prevented them from full observance of the Jewish law. Though some of them may have been notoriously immoral, the designation of them as ‘sinners’ was more a social characterization than a moral judgment.”¹ These are individuals whose activities placed them outside the definition of the sacred. Tax collectors would have easily fallen into this category, as they would have been employees of the occupying Roman forces. Suspected of treason, their job would also have been viewed as exploitative. Their profit would have been provided by the extortion of more than what was legally due in taxes and tolls.

The tax collector in the gospel of Luke and Mark is referred to as Levi, an unknown character. The gospel of Matthew refers to the tax collector as Matthew, implying that he was one of the twelve disciples. This possibility is congruent with the structure of the other gospels. The Marcan gospel has remarkable similarities between this passage and an earlier passage, 1:16, in which the disciples are summoned. The geographic location is identical in both, and both have “Jesus passing by (from the Greek *paragon*) and summoning Levi to follow (from the Greek *akolouthei*) him.”² These key words suggest that the act of summoning is meant to be identical in both passages. It is possible that the writer of Matthew, writing later using the gospel of Mark as a source, simply corrected this passage to reflect the list of disciples.³ The effect is to heighten the contrast between a disciple (who came to be seen as prophets and bearers of the word of God) and a sinner (a religious outcast).

The final scene of this passage at dinner heightens this contrast further. In the Lucan gospel the dinner is described as a “great banquet.” A recurring and important theme in Luke, eating together implies a total acceptance of one another. Eating together comes to be seen as a sign of “God’s desire to be with his creation.”⁴ The banquet becomes a sacred space in the midst of its quotidian aspects which fall outside the sacred.

This conflict forms the central message of this passage. It is an assertion of the sacredness found within the furthest aspects of quotidian experience.

Reflection

I WONDER WHETHER any aspect of Matthew changed in this moment. Did the sacred wipe away his quotidian aspects, or was Matthew a hidden disciple all along? I wonder whether the banquet was truly a moment of acceptance, or a tacit provision of sustenance – or both. Somehow meaning appears within the furthest reaches of day to day experience.

I struggle to understand how the eternal becomes accessible within the everyday. Moments in which I encounter the sacred are usually so removed from the rest of my life. They appear as moments set aside from life to encounter this other presence. In this passage I confront a sacredness which arises directly from the parts which are excluded. This passage suggests that the spiritual aspects of my identity are rooted in the everyday made holy. These are not two separate places but a common ground.

What role can the sacred play in the everyday? How can the everyday experiences of the city reflect these ineffable moments of communion? How can the city occupy the edge between the sacred and quotidian?

.iv The Creative City

THE MATERIAL OF THE EARTH is physical and tangible. It is fixed in materiality, so distinct from the ineffable world of the spirit. How do these building blocks reach out to the ineffable? Architecture has always acted to preserve meaning. Through the material we begin to interact with collective projects of meaning. How can the temporal structure of contemporary quotidian space participate in this function?

The experience of modularity and indeterminacy along Bay St. provides our secular age with a plurality of options, but the language of mechanical reproduction creates an absence of expression. The material serves functional purposes in its economy of means, maintaining a neutrality of expression. DiCicco's collection of manifestos argues that this is not a livable city. He proposes a common ground which can reflect the richness of the human spirit.

DiCicco points to creativity as a necessary process in the construction and inhabitation of our common ground. The 'creative city' is one that "rejoins the project of dreaming and the project of building."⁵ A civic vision is not found in "bad planning, or good planning...[a] better allocation of capital funding or public money or private sector initiative...[or] schools of aesthetic, or schools of thought." DiCicco sees creativity as more than just an artistic creation, but the shared expression of human desire. "The cause of urban illness or the health of urban serenity is to be found in the relationship between primal human desires and the construction that mirrors them or stunts them"⁶. The space of the quotidian must give space to these desires.

As DiCicco illustrates, the expression of a common ethic is challenging in our age of diversity. He argues that creativity, "common delight and shared imagination and wonder." are our only tools. These do not clarify ontology in the same way that the temporal structures of St. Basil's does. DiCicco says that creativity offers metaphors for ontology, and "these metaphors are windows from which the citizen glimpses the spectrum of the ineffable."⁷ Rather than an edge between the material and the ineffable, DiCicco is proposing a window, a threshold which allows us a passage between. Windows separate and distinguish two zones, but also allow a passage of light, and sound, temporarily blurring the edge. For DiCicco creativity encourages the expression of the personal truths of the human spirit in

figure 3.1

Mechanical reproduction creates a quotidian space of repeating elements and dimensions. These repetitions create a repeating rhythm of the quotidian. Interrupting this rhythm gives spaces for interaction. By peeling open this rhythm, space begins to provide expression of the creative.

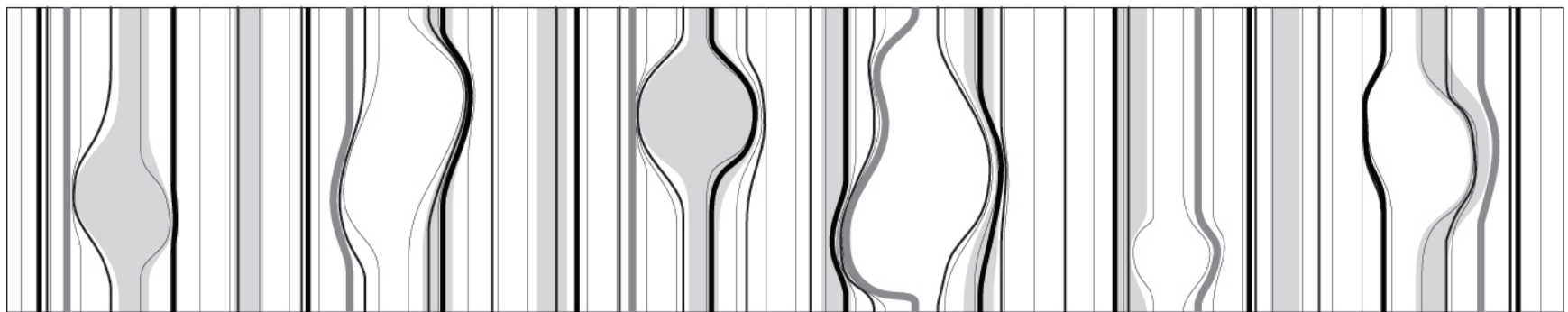
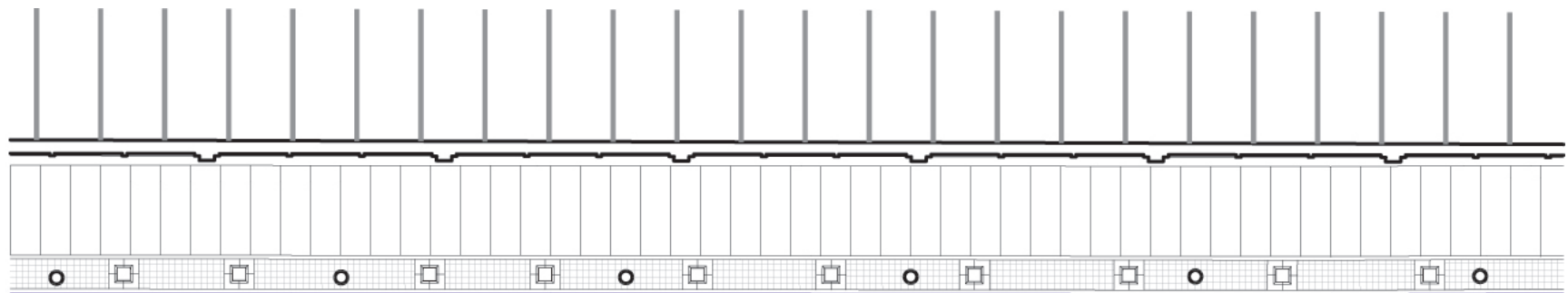

the shared space of the city. A creative city is one which provides these windows, allowing space for thresholds to personal truths of the human spirit, and hence, to the sacred.

The integration of these thresholds into the space of the quotidian suggests an interruption in the structure of indeterminability. The freedom of options and access can be opened up to the inhabitation of place. These openings give space to the gathering and expression of relationship. The rhythm of Bay St. can temporarily pause to provide thresholds towards St. Basil's.

The process of generating these thresholds can be both an act of design and construction. While DiCicco's text is vague about the architectural principles of the creative city, Vesely seeks to define a communicative architectural language in *Architecture in the Age of Divided Representation*. If providing windows to the ineffable in the quotidian is about expressing meaning, then Vesely provides the tools for doing so. Vesely works to replace the language of mechanical reproduction through a new poetic. For Vesely a 'poetic' is a way of making, the process of "bringing into being of something that did not previously exist."⁸

This poetic guides design intent from an "experience of appearances" to the experience of an "ethos."⁹ It illustrates the possibility of a shifting focus in the design process. Vesely proposes the rehabilitation of geometry from solely a mathematical abstraction to a experiential

figure 3.2
The peeling open of indeterminateness of the quotidian creates opportunities for encounter.

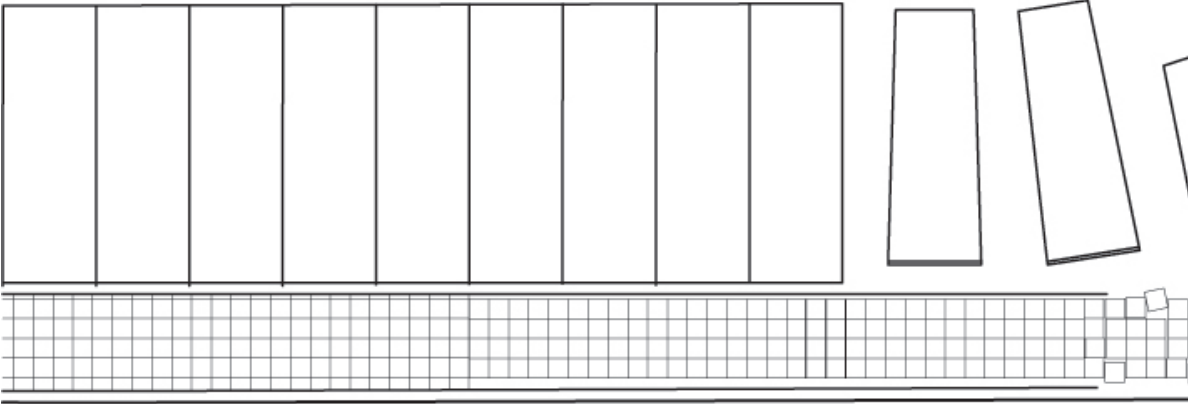

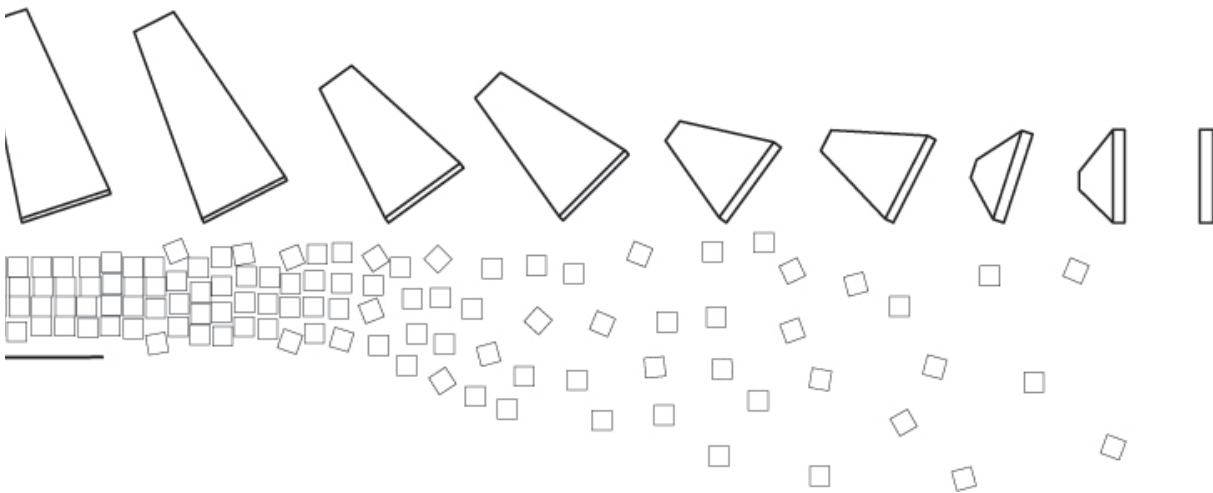
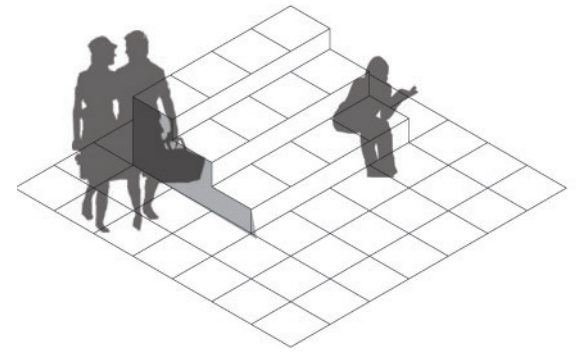
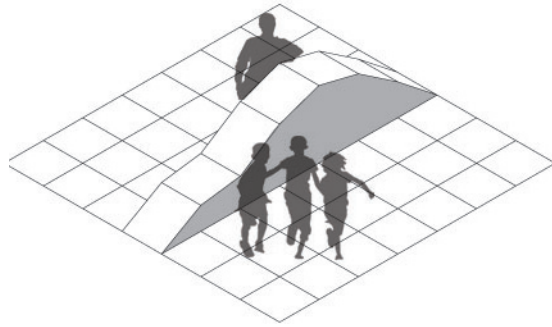
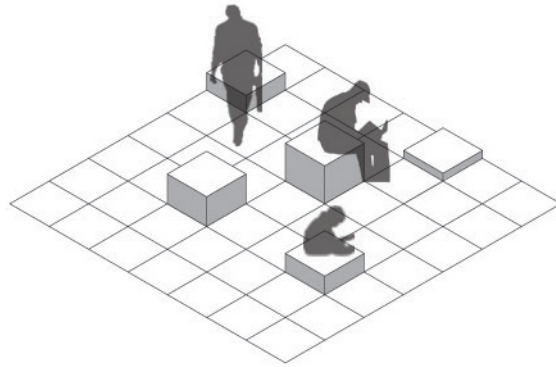
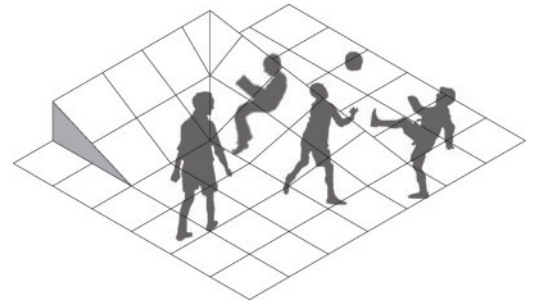
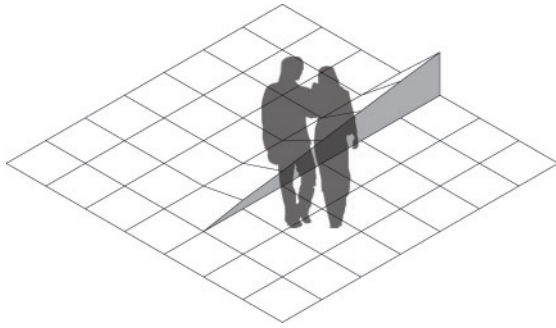
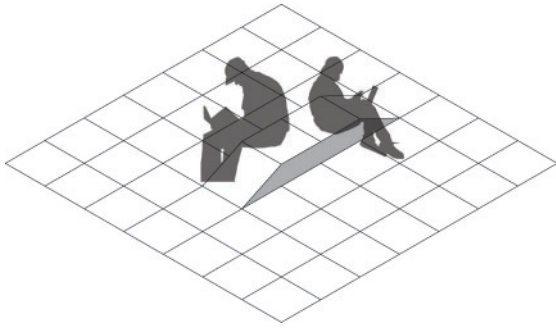

component of being: fundamental geometries such as horizon, up/down. Similarly, the concept of praxis, which seeks to relate the purpose of the project to its construction, acts as a component of communicative architecture. Here Vesely emphasizes not only the “content, but also the fulfillment of the project.”¹⁰

Vesely’s poetic seeks to orient the process of design and construction to one which expresses our human condition in its physical and intellectual breadth. This poetic illustrates the architectural process which grounds the construction of DiCicco’s ‘creative city.’ Communicative space forms a poetic for the process of designing and constructing DiCicco’s windows into the ineffable.

The creative city is one which manifests the spirit of its citizens, communicating the deepest desires of their hearts. While the time of the *saeculum* is uniquely ours, we must find a language to give voice to that which is beyond the time of the ‘now.’ DiCicco points towards the ‘creative city’ which can be a place built on the expression of shared wonder and imagination. Vesely illustrates a poetic that expresses the communicative function of architecture. Through these moments we begin to imagine thresholds from the sacred into the quotidian.

figure 3.3

Turning edges into thresholds involves expanding the two faces of the border to occupy the edge itself. Expanding out, these edge conditions become inhabitable spaces transitioning between the two faces of a line

.v Thresholds

FINDING WINDOWS FROM secular time into the time of the sacred involves a transition from the understanding of boundaries as edges to thresholds. The edge as a border between the sacred and quotidian distinguishes separate temporal structures in architecture. The space of the sacred is defined by this border, which encloses a unique and private spatio-temporal structure. The border divides this from the experience of the quotidian.

In seeking to occupy a border, this separateness is challenged. As DeCicco and Vesely both write, the role of our civic space is to participate in the expression of our desires and understandings of meaning. The common space of our everyday life must reach out to structures which support and mirror these desires. DeCicco imagines these connections as 'windows' into ontology – thresholds which exist between.

The term 'theshold' implies a crossing between distinct zones, but refers to that third, momentary space of 'inbetween.' This zone between is the space within the edge. We recognize the multiple layers of material that distinguish between the sacred and quotidian. Each face of this border responds to the distinct zones it encloses. Turning

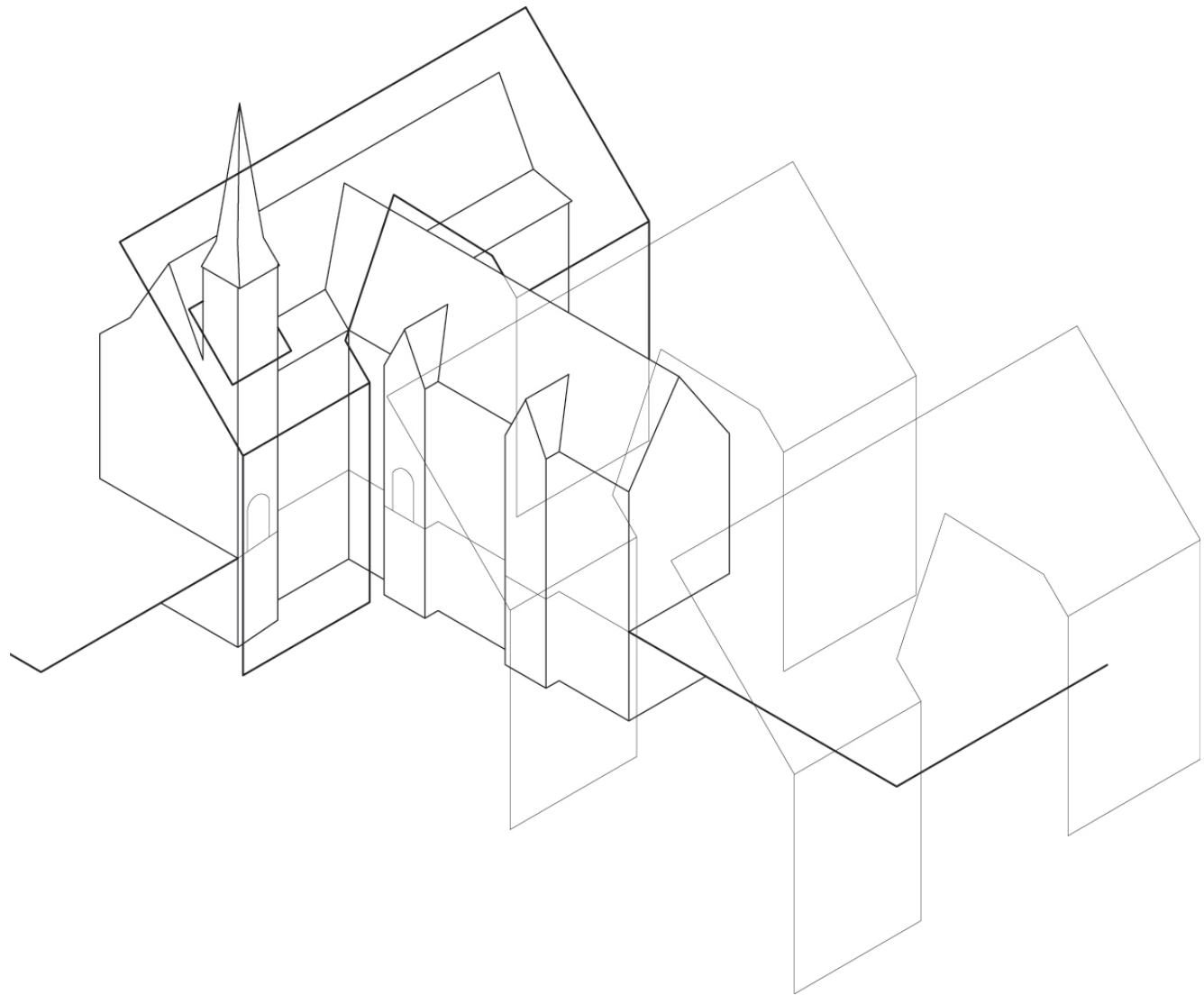

these edges into thresholds involves expanding the two faces of the border to occupy the edge itself. Expanding out, these edge conditions become inhabitable spaces.

The analysis of the edges at St. Basil's Church in Part One informs the exploration of thresholds. These edges are not impermeable lines but layer upon layer of material laminated together. The zone within them is a physical space which can be expanded and occupied. The minute air pockets between the faces of screen, glass and plastic (see page 28), the enclosed space between the ceiling and the roof (see page 26) form spaces which filter and protect the inside from the outside. The transitional zones of the narthex (see page 24) and the ramp (see page 30) already begin to allow an occupation of the edge, but are limited in their connections and relationship to the quotidian. Expanding these edges explores an occupation of the border.

This inbetween space belongs to neither face of the edge, but acts as a transition. These spaces are, conceptually, 'windows' into ontology, that allow the delicate negotiation between the sacred and quotidian. Edge becomes threshold. Thresholds are places of passage and transition. These thresholds give space for the 'creative city' allowing the expression of the ineffable in civic space.

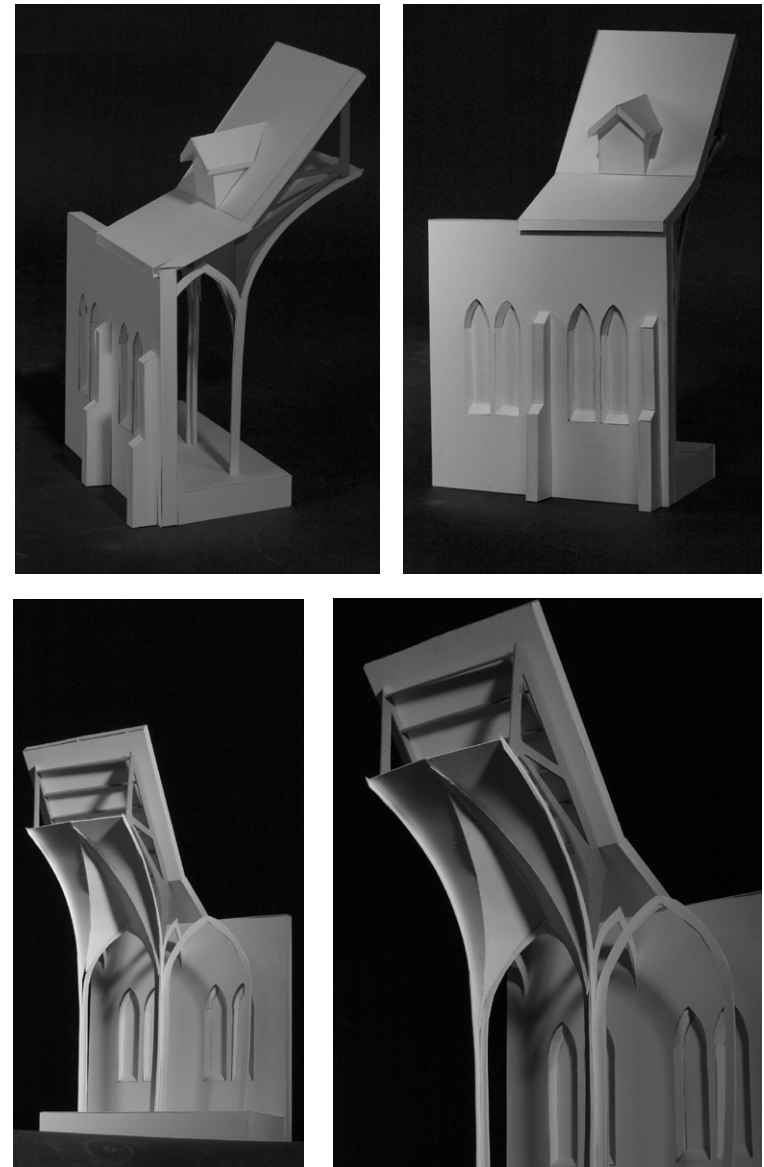
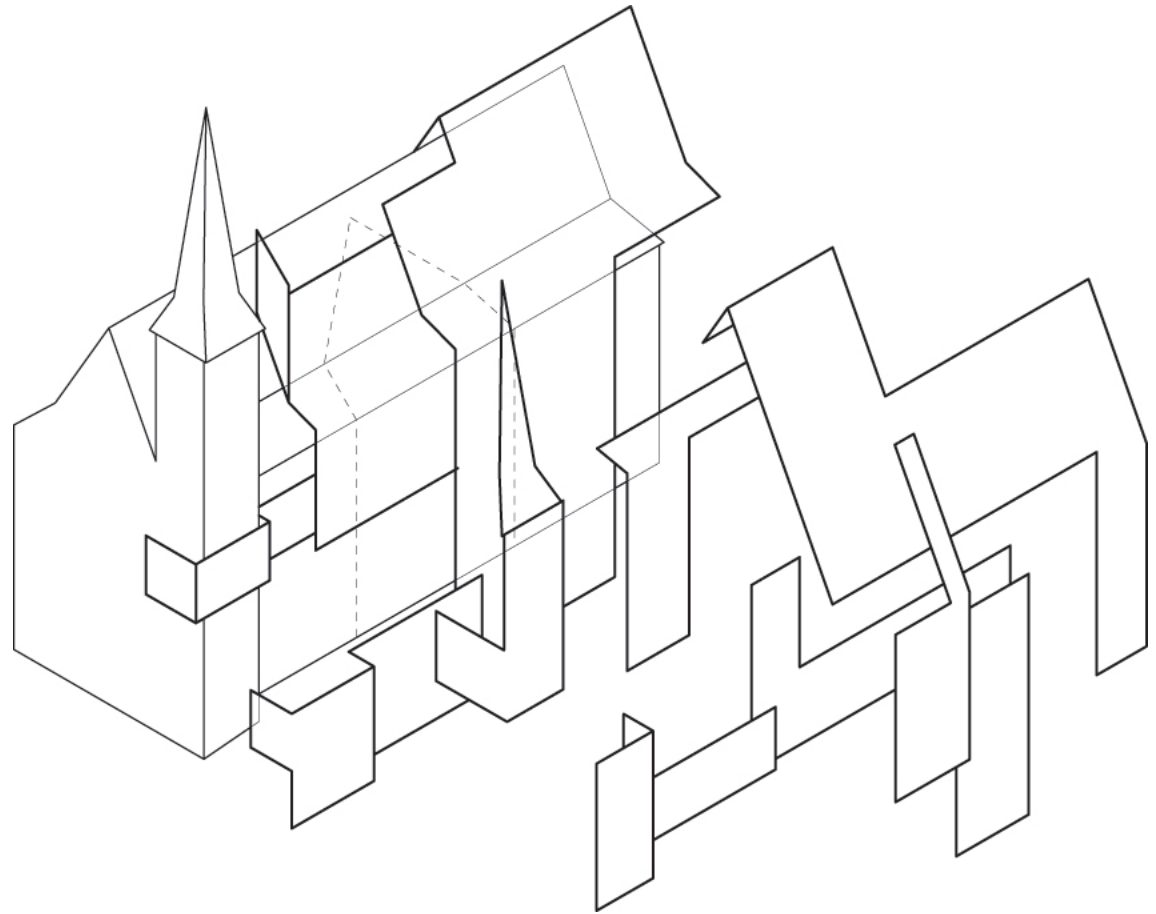
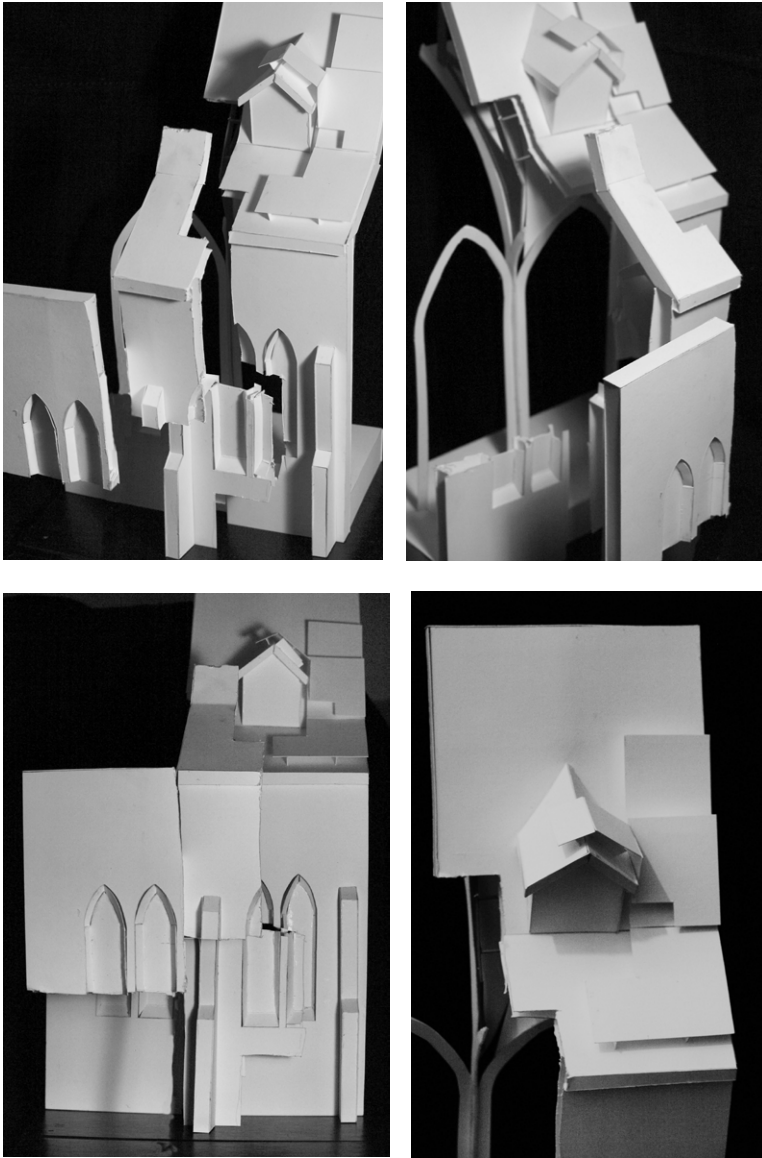
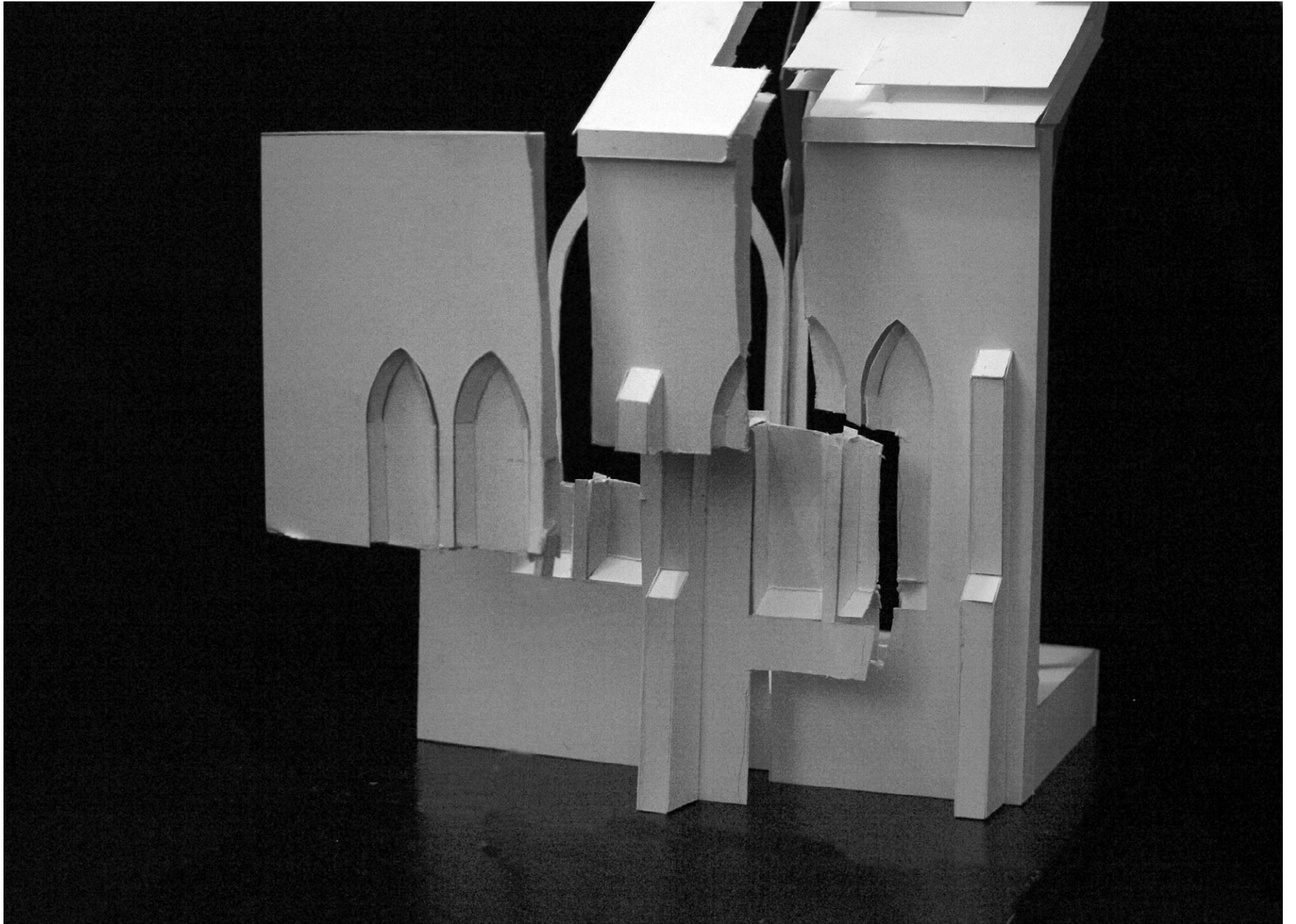
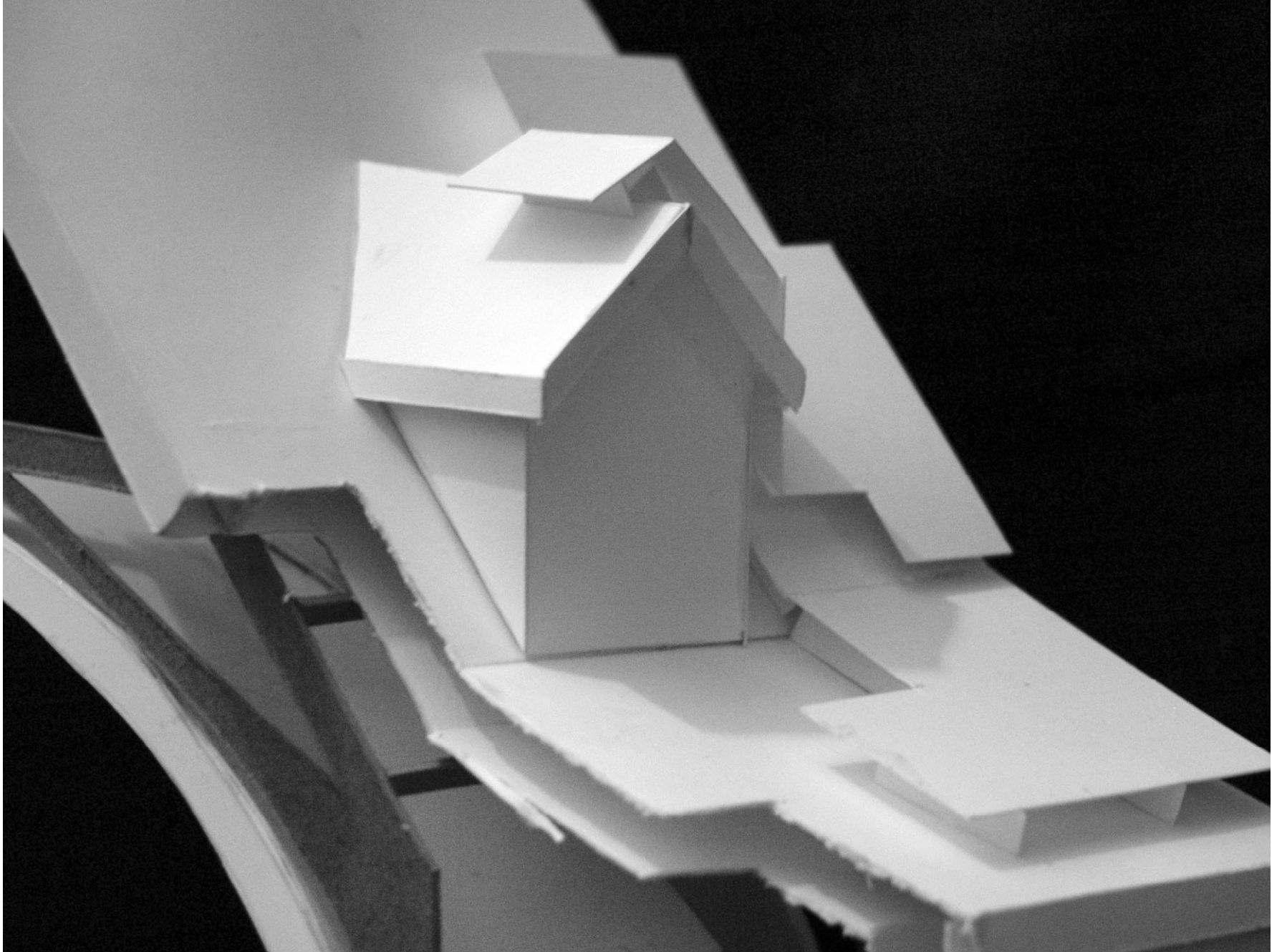

figure 3.5.
A model of the existing wall and roof which form a part of the edge between St. Basil's Church and Bay Street.



*figure 3.6, (3.8 & 3.9 on following pages)
A model of the existing wall and roof peeled away uncovering the space
between the materials. The edge becomes threshold.*





v. Design

DiCicco's 'windows onto ontology' suggests the architectural element of thresholds as a response to the border between the sacred and quotidian. These design images explore the creation of thresholds which begin to relate Bay Street to St.Basil's Church, and vice versa. Their poetic is guided by the experience of sacred and quotidian time, and possible transitions between them. This begins to act as a communicative architecture – the design gives a voice to the narratives of the sacred, and communicates interactions between the city and the church.

The experience of transition is explored in several conditions. Some are more direct, allowing an integration of the two spaces across the threshold, while others are perceptual, allowing connections but not access across the threshold. In all cases however, the border between the sacred and quotidian has been expanded to become an occupied zone. Rather than a line, a zone is a defined space. The occupation of the border transforms the edge into threshold by creating a third space which is a blending of the church and street.

The materials of the walls and roof of the church literally slide away and begin to spread out. The architectural operation involves fragmenting and re-using the materials of the edge to create the threshold . Existing edge conditions such as the ramp are expanded and refined to articulate their architectural role. In various ways, edge conditions have peeled outwards to begin interacting with and blending the space of the quotidian.

Interacting with these fragments of the edge begins to interrupt the rhythm of the quotidian. The experience of these zones is about moving between two distinct spaces. Views, sounds and activities are opened up, layered, or connected. These experiences try to find possible interactions between the experience of the sacred and quotidian.

Three zones have been explored in order to describe specific thresholds. The east wall of the church supports the direction of ritual within the church and looks onto Bay Street. The current ramp connects the parking lot to the existing basement. Finally the north wall of the church acts as the terminus to the ritual and has a blank wall overlooking a large expanse of grass.

Through the design drawings experiences and aspects of threshold are explored as the space of the quotidian begins to meet the space of the sacred.

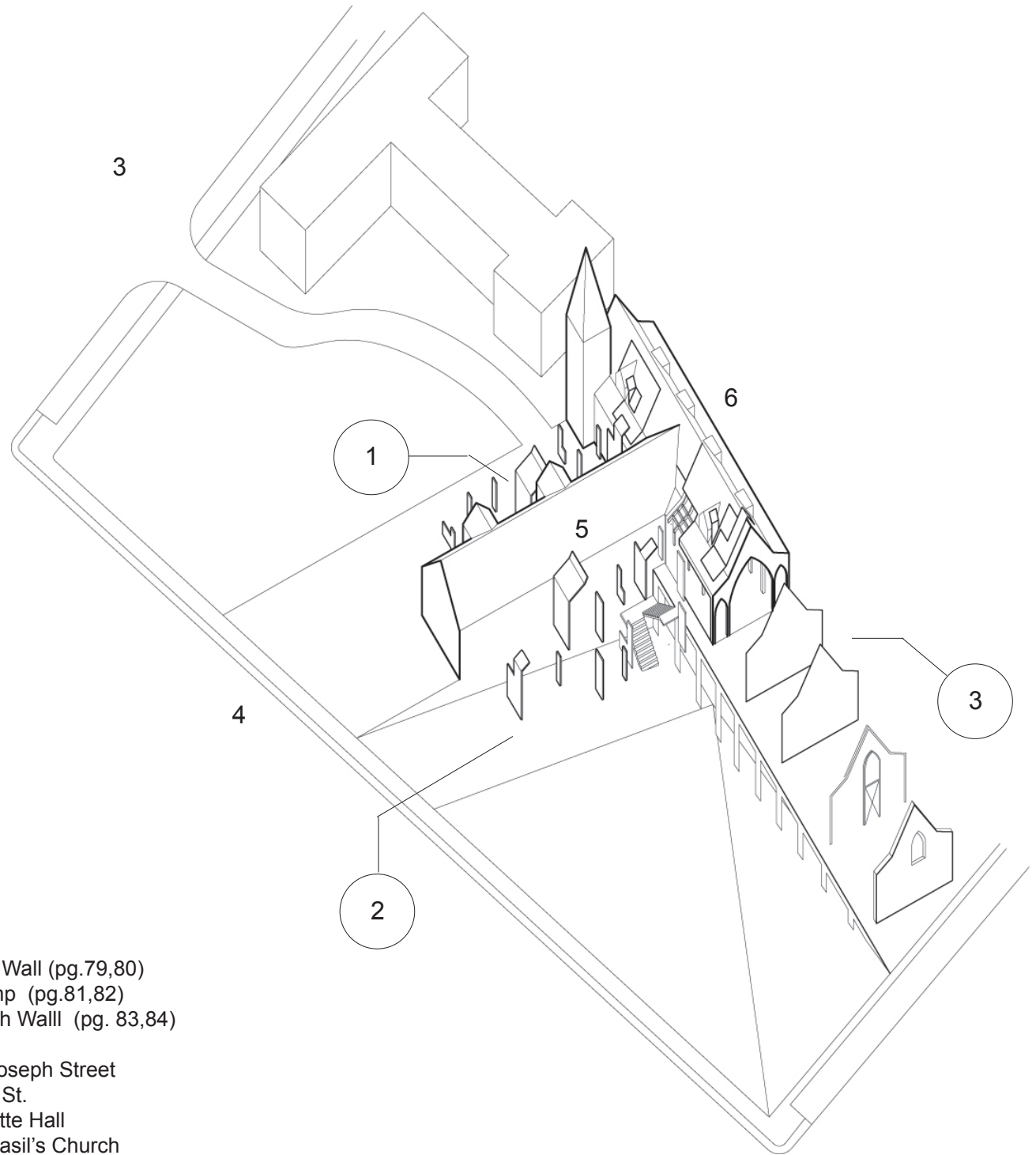
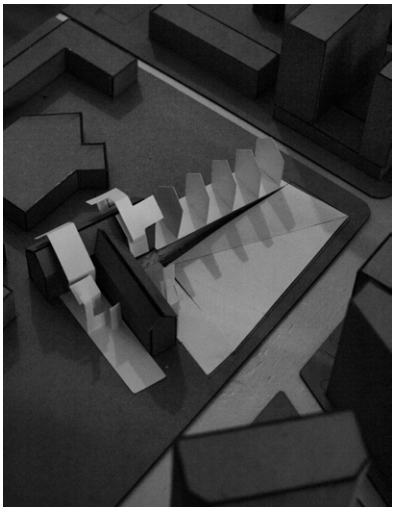
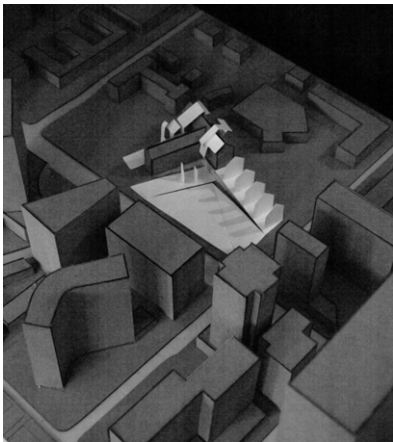

- 1. East Wall (pg.79,80)
- 2. Ramp (pg.81,82)
- 3. North Wall (pg. 83,84)
- 3. St. Joseph Street
- 4. Bay St.
- 5. Odette Hall
- 6. St. Basil's Church

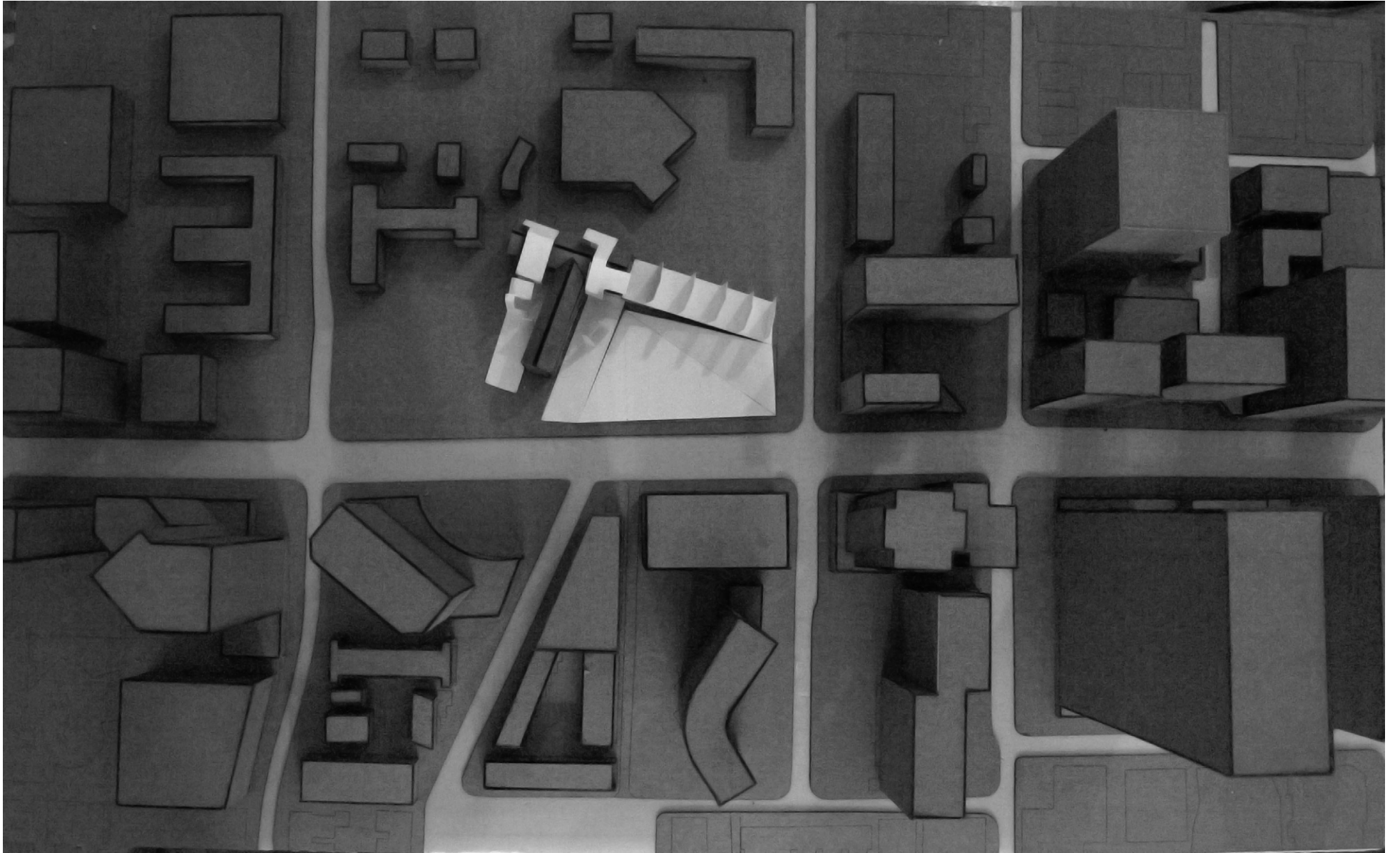

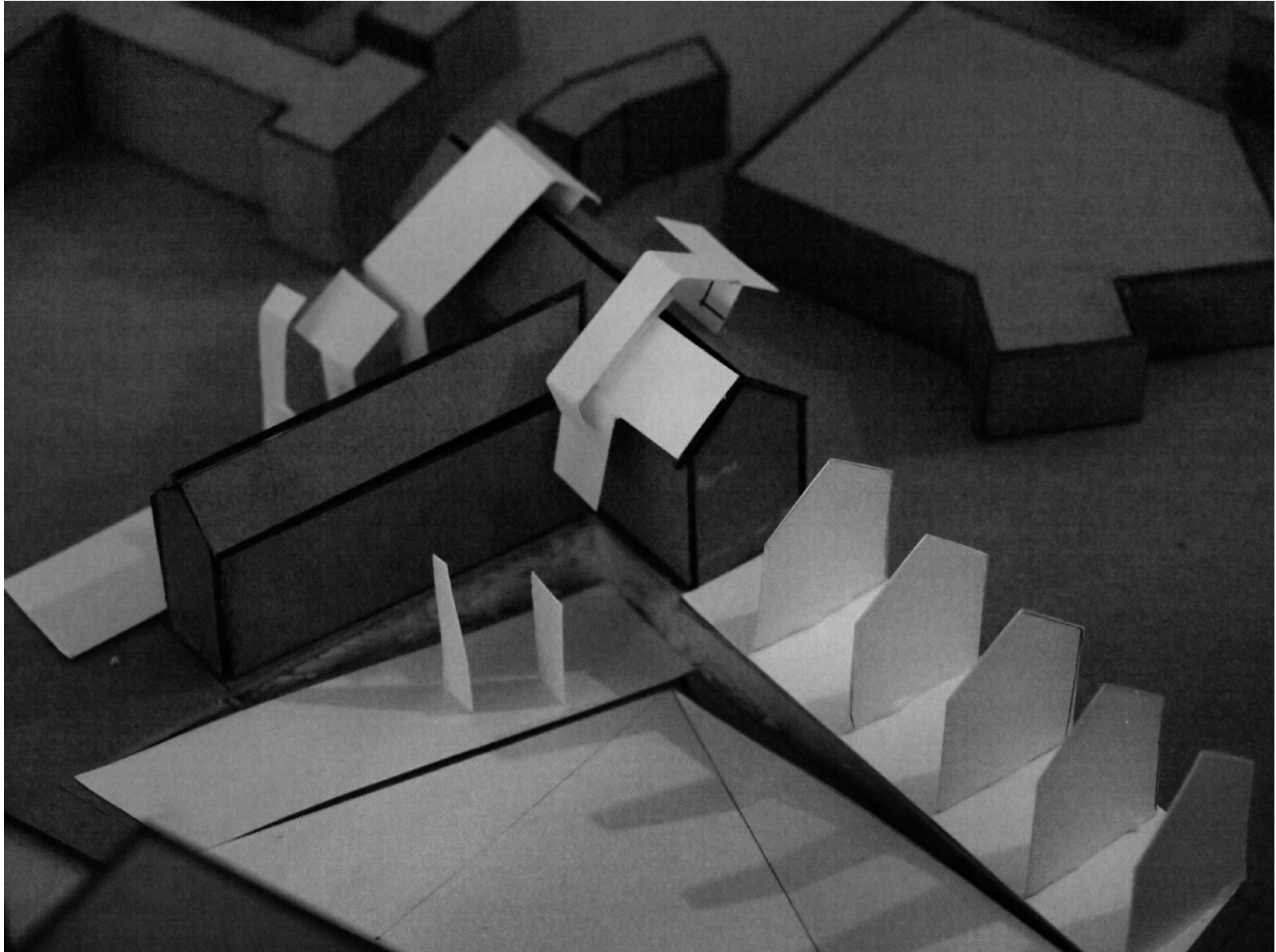

1



3



2

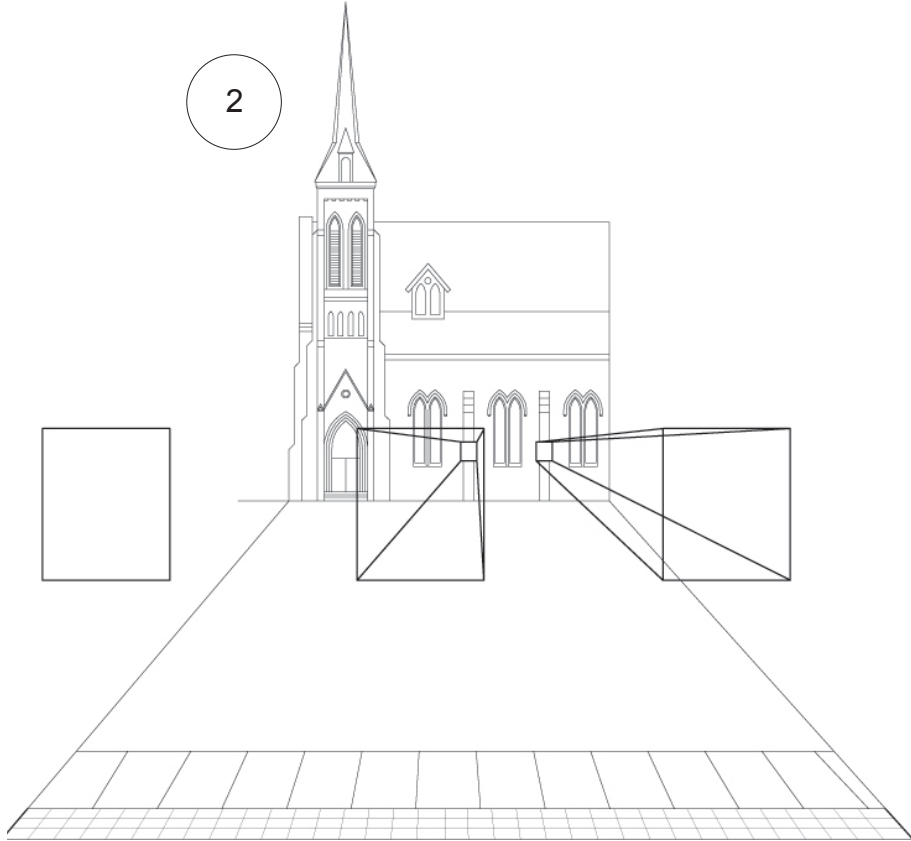

4

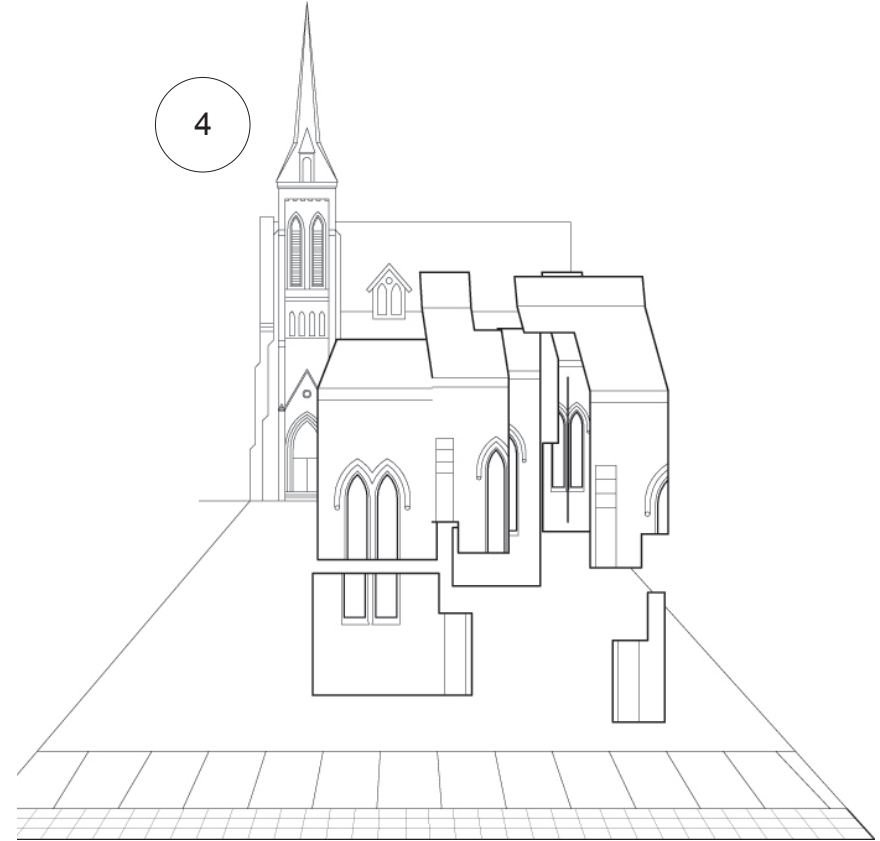

1. East Wall

The East wall currently supports the longitudinal direction of ritual within the church. Facing onto Bay St. the east wall is made up of layers of brick, plaster, glass, wire cage, and plexiglass. These materials are peeled outwards along an axis which draws them towards the sidewalk along Bay Street. While the wall is broken up into many materials and pieces, its entire surface area remains intact with the exception of two openings. The effect is to appear intact when viewed orthographically.

Two small openings are removed and pierce across the site. They align a standard rhythm of glimpses along the sidewalk with the rhythm of the stations of the cross on the interior of the church. These brief glimpses are the only direct contact between St. Basil's and the sidewalk. Following along these connections, the view begins to open up. Passing the fragmented materials of the wall, the visual and auditory connections become stronger. Slowly one is opened up to the church or the street.

The experience of this threshold acts to blend the temporalities of the sacred and quotidian. The seasonal liturgical cycles, as well as the weekly and daily changes in light and sound within the church are registered

from the street. Similarly the church is opened to the quotidian experiences (light, sound, movement) of the street. These experiences are mediated by the fragments of building which gradually open up each experience.

The architectural strategy of this

threshold relies on movement. Rather than a static architecture which communicates a connection, moving along an axis provides a gradual experience of opening. This act of inhabiting the threshold generates within the architecture a transitional experience.

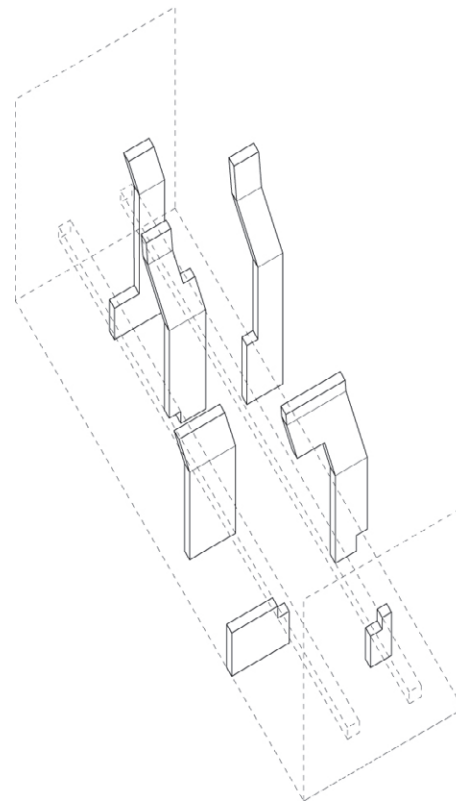

figure 3.15.1 map of the solid space between the sidewalk and St. Basil's showing a possible arrangement of the fragmented materials.

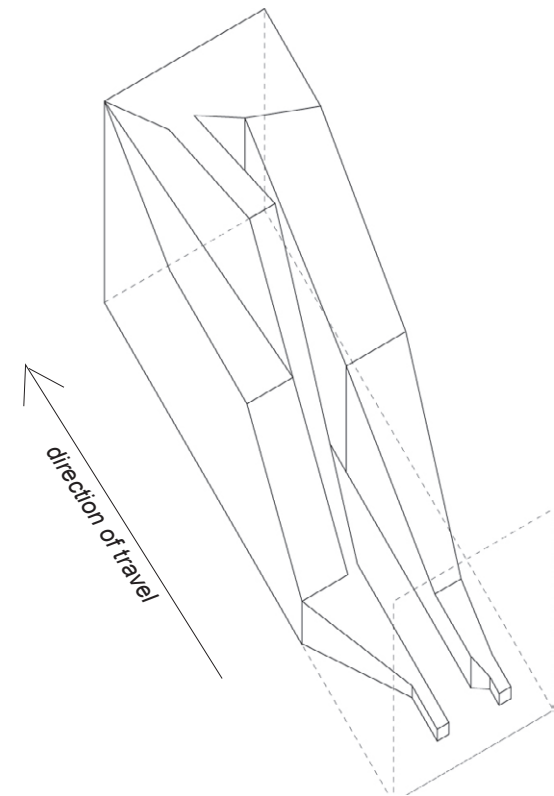
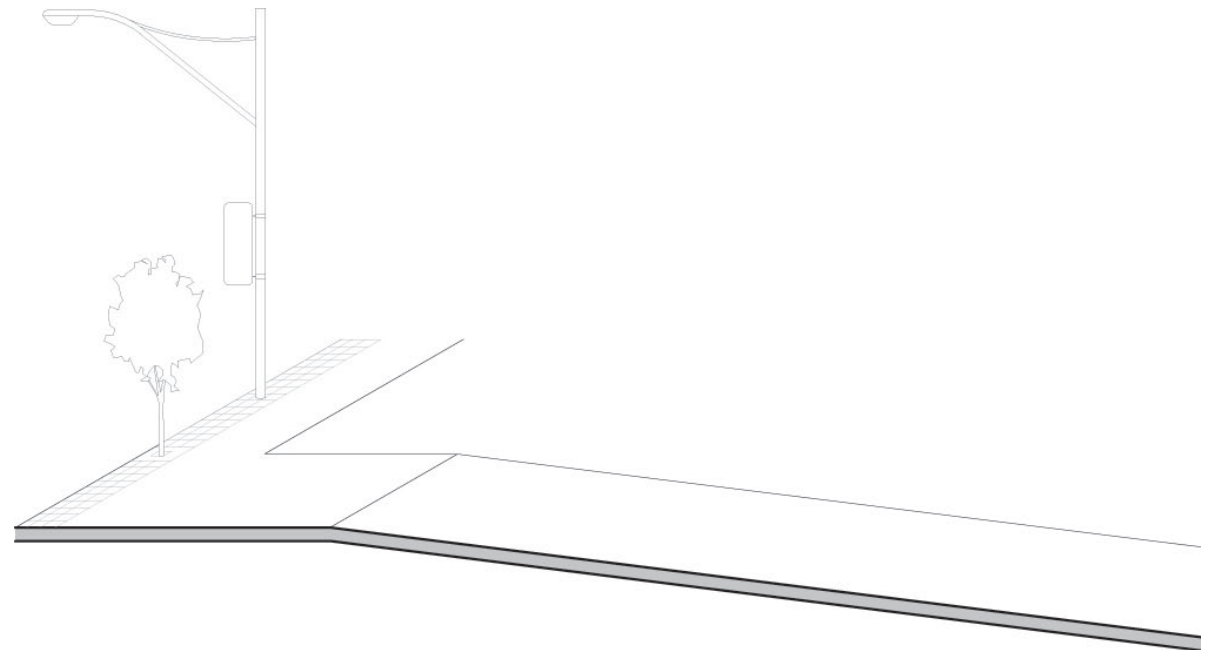
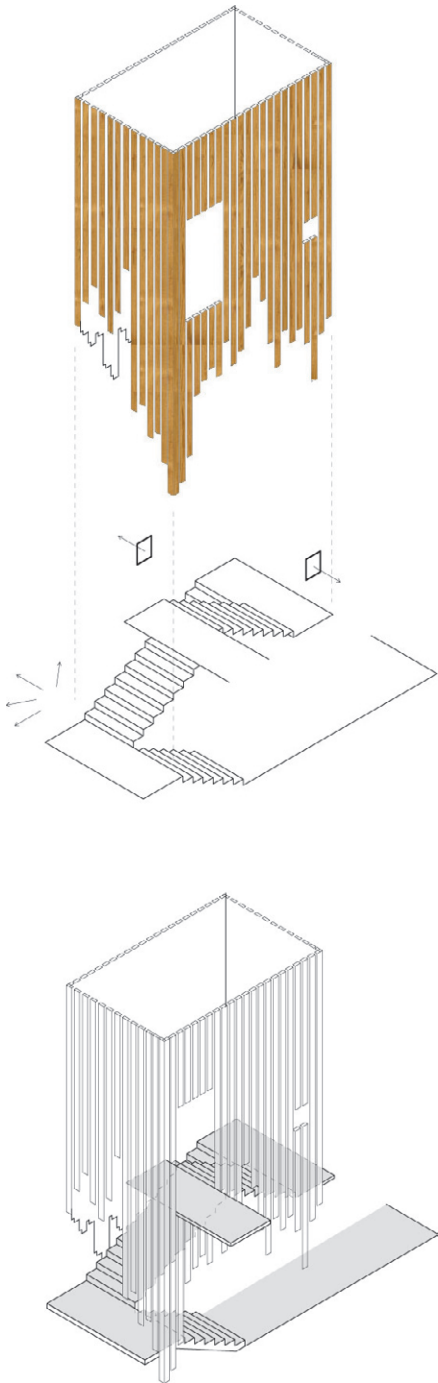

figure 3.15.2 map of the void space between the sidewalk and St. Basil's showing the opening up of view and sound in the direction of travel

2. Ramp

An existing ramp connects the parking lot to the basement of the church. While minimal and discrete, this ramp has a critical function. It provides access to the church hall which hosts a variety of community related functions such as an “Out of the Cold Program” and a “Food Bank.” These functions directly support the inhabitants and activities of the quotidian. The church hall also acts as an extension of the sacred space as it is the architectural representation of the sacred in action.

The ramp is rotated and extended across the site to become continuous with the sidewalk. The street slowly changes grade connecting the sidewalk to the church hall directly. A new staircase becomes the architectural representation of a vertical connection to the sacred along this horizontal movement. The staircase acts both as a connection to the sanctuary and a gateway to the church hall.



The experience of these two geometries reflect their individual roles. The ramp provides a smooth and continuous surface, creating direct connections to the church hall. Its scale and surface generate a large open space. In contrast the stairwell is enclosed by a wood skin which peels away providing stronger visual connections as one descends from the sanctuary to the hall. The nature of the motion when ascending/descending the staircase is always back and forth. Criss-crossing between framed views to the city and to the church, the stairway acts to weave together views of the sacred and quotidian along this vertical journey.

The architectural strategy of this threshold involves aligning programs and geometries. The horizontal access is used to connect related programs such as the street and the church hall. The vertical access is used to express more abstract connections such as the church hall to worship. By organizing programs, and aligning them to geometries, interactions are facilitated.

figure 3.16

sidewalk grade is connected to the church hall beneath the sanctuary by a ramp which stretches across the site. The vertical connection to the sanctuary is maintained by a new stairwell

the staircase is a criss-crossing motion moving between framed views of the city and church

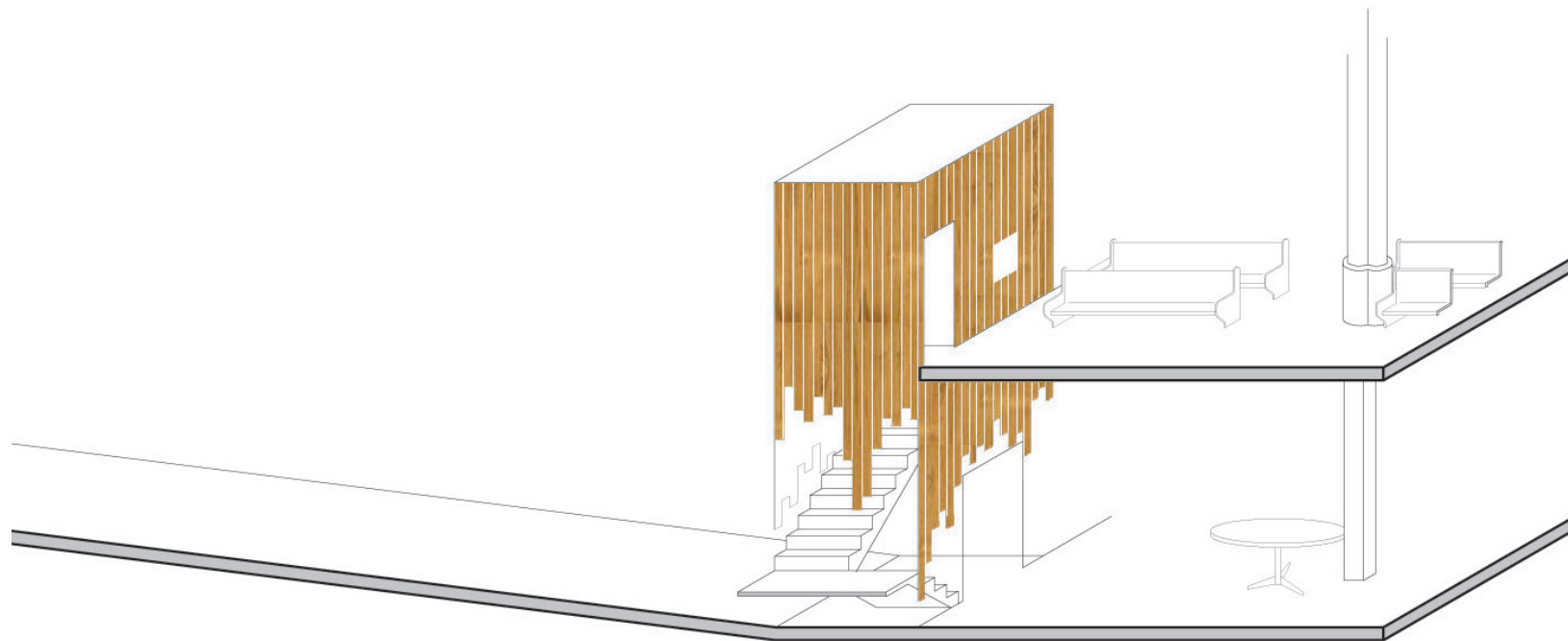

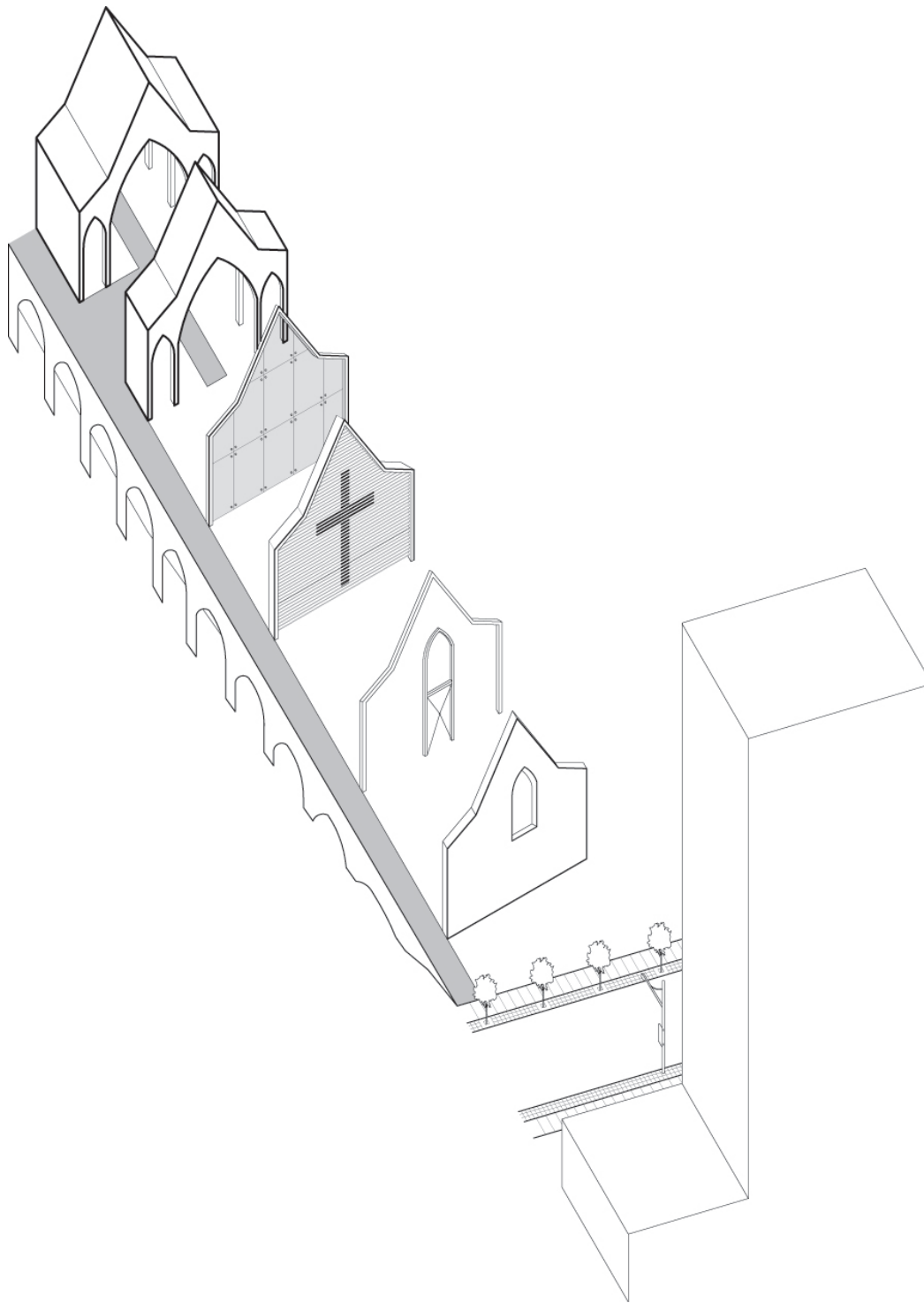

3. North Wall

The North Wall acts as the terminus to the axis of ritual within St. Basil's Church. Typically this wall hosts several narrative functions containing the tabernacle and crucifix. It projects the axis of ritual forward into the future of redemption. Its outside surface however is conversely bare, a blank wall facing the city.

The wall is expanded outwards stretching from its current position to the sidewalk along St. Mary St. Several new walls provide echoes of this wall, but allowing a filtering of light through their materiality. These new walls act to layer the narrative role of the north wall, incorporating the light, views and experiences of the street into this narrative.

The experience of these walls acts to overlay narrative onto both the church and street. From within the church, the successive layers of semi-transparent surfaces overlay the traditional symbols of the crucifix, and the stained glass window, but also views of the street and buildings outside. Because of the space between the various walls, activities which occur are over-layed onto the function of the north wall. These experiences suggest that the projected future incorporates and involves the activities beyond. The structured

future time of the sacred begins to open itself up to the movements and patterns of the city. Similarly, fragmented views of the activities within the church are overlaid onto the experience of the street. The zone that these filters create takes on the aesthetic of a bridge which allows a movement across these filters into the church.

The architectural strategy of this threshold relies on overlapping experiences which are mediated by filters. Light is used in a variety of ways to overlap experiential and symbolic elements. Varying transparencies allow an interplay of the structured narrative of sacred time with the open possibility of quotidian time.



figure 3.18
layers of filters are spread across the site

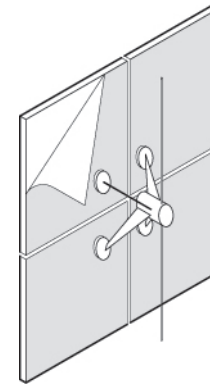

a semi-transparent film is applied to a glass wall

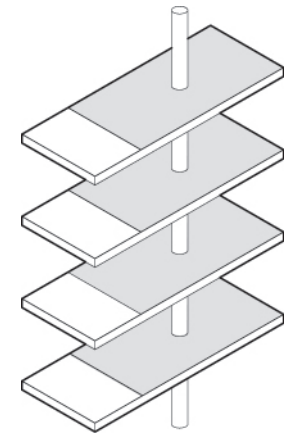

horizontal slats partially obscure view. A reflective coating on the top surface of the panels overlays a crucifix

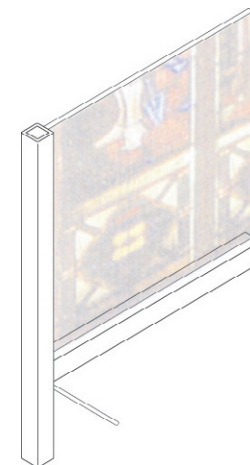

the existing stained glass panel is removed and supported in a frame.

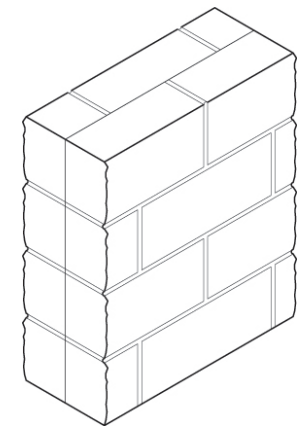

existing brick wall



sky; the everyday in the divine

The sky is the vaulting path of the sun, the course of the changing moon, the wandering glitter of the stars, the year's seasons and their changes, the light and dusk of day, the gloom and glow of night, the clemency and inclemency of the weather, the drifting clouds and blue depth of the ether. When we say sky, we are already thinking of the other three along with it, but we give no thought to the simple oneness of the four.

§10, §108 The Rejection at Nazareth

Mk 6:1, Mt 13:54, Lk 4:14

²*On the sabbath he began to teach in the synagogue, and many who heard him were astounded. They said, "where did this man get all this? What is this wisdom that has been given to him? What deeds of power are being done by his hands!*

³*Is not this the carpenter, the son of Mary and brother of James and Joses and Judas and Simon, and are not his sisters here with us?" And they took offense at him.*

⁴*Then Jesus said to them, "Prophets are not without honour, except in their hometown, and among their own kin, and in their own house."*

⁵*And he could do no deed of power there, except that he laid his hands on a few sick people and cured them.*

Mk 6:2-6a

THIS PASSAGE is found in all three of the synoptic gospels, although at different points of the narrative. The story follows Jesus speaking in his local temple, being rejected for his heritage, and a rebuttal which compares Jesus to the prophets of the Old Testament. Central to all three versions of the story is the idea of sacredness juxtaposed against commonality.

It would not have been uncommon for an adult male to speak within the synagogue. Within Nazareth it would have been perfectly acceptable for Jesus to read from the Torah and share a reflection¹. The rejection ascribed to the crowd would have been in response to something much more shocking.

In the Marcan gospel, this passage is the anti-climax to a series of miraculous signs of power and precedes the sending out of the twelve disciples. It is these signs which the crowd reacts to. The rejection is a stark contrast to the preceding image of a powerful and influential prophet suggesting that Jesus “could do no deed of power” there. The author of Matthew softens this contrast slightly. The Rejection at Nazareth finalizes a chapter which consists of Jesus’ parables and ends suggesting that he chose to conceal his power: “and he did not do many deeds of power there”.

Luke's account occurs at the beginning of the gospel story, creating a smoother narrative arc out of the gospel from initial rejection, to popularity, and eventual rejection/crucifixion. The reordering of the Lucan gospel forces the author to lengthen the passage. Instead of being seen as a rejection of miracles/teachings which came in a preceding passage, the author of Luke must provide the same information within the scene. In the Lucan gospel Jesus makes an explicit claim to be the Messiah². After reading the scroll of Isaiah, Jesus proclaims "today this scripture has been fulfilled in your hearing." It is this idea, implicit or explicit in all three gospels which the crowd rejects.

After this claim, all three gospel writers include the same response. A list of Jesus' heritage and occupation is used as a rebuttal to his claim of spiritual power. Curiously, Matthew and Mark's gospel refer to Jesus as "son of Mary" as opposed to "son of Joseph". It is possible that this could be considered an insult as most individuals were identified by their paternity³. In response to the crowds rejection, Jesus refers to the Old Testament figures of Elijah and Elisha, two other prophets who were rejected for claiming to speak on behalf of God.

Within the passage the major conflict that exists is between the supernatural and commonplace aspects of Jesus. The crowd cannot resolve the contrast between these opposites. They are disturbed at Jesus' demonstration of both.

Reflection

THE GOSPELS ARE filled with narratives which depict Jesus as the martyr, suffering for his spiritual mission. This passage is no different, although the reasoning given is unique. I am stirred by the blunt rejection of Jesus not because he is extraordinary, but because he is too ordinary.

I wonder what I choose to forget in my attempt to be holy. How can the sacred, so other worldly, be so deeply rooted in the physical? Like the crowds in the temple, I too am shocked and scandalized that the depth of truth and meaning could be wrapped up in physicality. I am moved by the emphasis on the earthly which is also strangely holy.

What role can the everyday play in the sacred? How can the infinite and the indeterminate experiences of everyday life become a part of the rigid structures of the sacred? How can the church occupy the edge between the sacred and quotidian?

.iv The Material and the Divine

CHRISTIAN SACRED SPACE has relied on a temporal model in order to invoke divine qualities onto the material world. The presence of the divine is revealed in the world as all material transforms towards an eventual renewal in the fulfillment of time. As has been shown in part one, contemporary sacred space has had to react to a secular culture which recognizes this temporal framework as one amongst many. Contemporary sacred space reveals a highly tuned expression of edges which architecturally generates a border between the time of the sacred and the time of the everyday. The result is an emphasis on the numinal as an abstract and personal experience of the sacred. Historically however, sacred architecture has been used to unite an understanding of the material and the divine.

In his survey of Christian architecture through time, the theologian and historian Andre Bieler explores the types of spaces used for worship in early Christianity. Homes, attics, catacombs and public buildings were informal gathering spaces for worship⁴. These informal architectures testified to the fact that the sacred existed in all creation. The growth in adherents and the need to formalize structures however, posed a serious concern for the construction of permanent spaces of worship. The development of a temporal architecture which could relate the material and the divine is revealed in the developments within medieval thought.

Representations of space in the development of maps between the 7th to 15th C present this temporal space. This qualitative and conceptual method of cartography emphasized temporal relationships over spatial ones. Their highly uniform structure placed Jerusalem at the center with the Mediterranean dividing Europe, Asia, and Africa in a 'T' shape. The encircling ocean gave these maps the familiar T-O structure⁵. Most significant about these maps was their conceptual quality. Physical distance and size was less important than conceptual structure. The Garden of Eden is typically placed in the East, and the location of biblical events and locations is plotted along with contemporary inhabitation. The world was understood as a spatial and temporal whole, collectively caught up in a movement towards fulfillment. A representation of the everyday world was placed alongside biblical events, drawing both into a larger narrative.

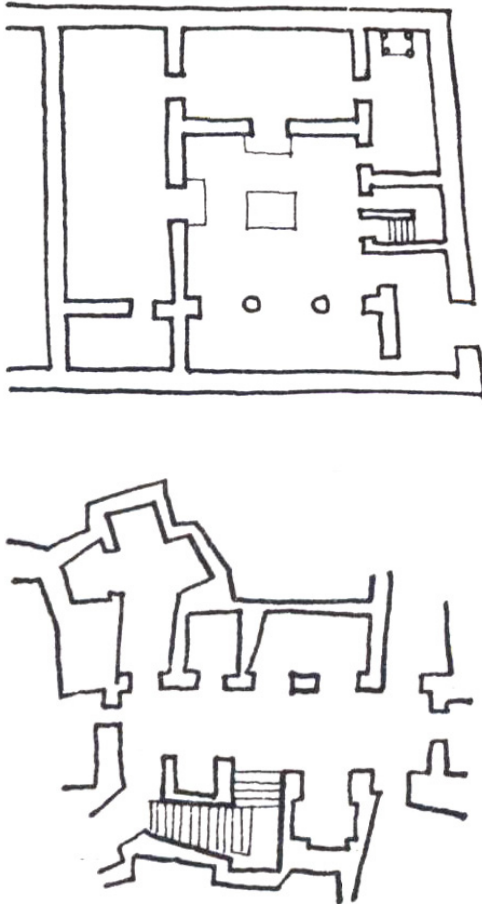

figure 4.1 (above)
Bieler's drawings of early Christian worship spaces including attics/homes (top) and catacombs (bottom). Informal gathering spaces were testament to the fact that the sacred existed in all creation.

In the maps, the time of everyday life is considered equal to the time of the sacred. The entire world is caught up in a sacred narrative. The gothic cathedral shared in this structure to create a reciprocal model of the cosmos. By modeling the structure of the world, both physical and divine, the architecture of the gothic cathedral acts not as a space apart, but as a microcosm reflecting the structures of sacred time.

In his book *Gothic Architecture and Scholasticism* the art and architectural historian Erwin Panofsky suggests that the architecture of the Gothic cathedral became an experience of both the physical and divine. "Like the High Scholastic Summa, the High Gothic cathedral aimed, first of all, at 'totality' and therefore tended to approximate by synthesis as well as elimination, one perfect and final solution; ...in its imagery, the High Gothic cathedral sought to embody the whole of Christian knowledge, theological, moral, natural, and historical with everything in its place and that which no longer found its place, suppressed."⁶ In this quotation, Panofsky is referring to Thomas Aquinas' *Summa Theologica*, an encyclopedic text which attempted to systematically prove the whole of medieval knowledge including the



figure 4.2.
Hereford Map 13th C. Enlargements show the placement of the garden of Eden in the far East, located at the top of the map. The area around the red sea shows the crossing described in Exodus. Narratives of the sacred are placed alongside geographical features

| BIBLIOPHICAL NOTE | | QUESTION | | PAGE | |
|----------------------------------------------------------------------|------|-------------------------------------------------------------------------------|---------------------------------------------------------------------------------------|------|-----|
| BIBLIOGRAPHY OF PRINCIPAL REFERENCES | | 42. <i>Of Equality and Likeness Among the Divine Persons</i> | | 214 | |
| PROLOGUE | | 43. <i>The Mission of the Divine Persons</i> | | 230 | |
| CONTENTS, VOLUME I | | | | | |
| FIRST PART (Complete) | | | Treatise on the Creation | | |
| Treatise on God | | | 44. <i>The Procession of Creatures from God, and of the First Cause of All Things</i> | | |
| QUESTION | PAGE | 45. <i>The Mode of Emanation of Things from the First Principle</i> | | | 238 |
| 1. <i>The Nature and Extent of Sacred Doctrine</i> | 3 | 46. <i>Of the Beginning of the Duration of the Creatures</i> | | | 250 |
| 2. <i>The Existence of God</i> | 10 | 47. <i>Of the Distinction of Things in Particular</i> | | | 259 |
| 3. <i>Of the Simplicity of God</i> | 14 | 48. <i>The Distinction of Things in Particular</i> | | | 259 |
| 4. <i>The Perfection of God</i> | 20 | 49. <i>The Cause of Evil</i> | | | 264 |
| 5. <i>The Good in General</i> | 23 | Treatise on the Angels | | | |
| 6. <i>The Goodness of God</i> | 28 | | | | |
| 7. <i>The Infidelity of God</i> | 31 | 50. <i>Of the Substance of the Angels</i> | | | 269 |
| 8. <i>The Being of God in Things</i> | 34 | 51. <i>Of the Angels in Comparison With Bodies</i> | | | 275 |
| 9. <i>The Immutability of God</i> | 38 | 52. <i>Of the Angels in Relation to Place</i> | | | 278 |
| 10. <i>The Eternity of God</i> | 40 | 53. <i>Of the Least Movement of the Angels</i> | | | 280 |
| 11. <i>The Unity of God</i> | 50 | 54. <i>Of the Knowledge of the Angels</i> | | | 284 |
| 12. <i>How God is Known By Us</i> | 60 | 55. <i>Of the Medium of the Angelic Knowledge</i> | | | 288 |
| 13. <i>The Names of God</i> | 69 | 56. <i>Of the Angels' Knowledge of Immaterial Things</i> | | | 291 |
| 14. <i>Of God's Knowledge</i> | 75 | 57. <i>Of the Angels' Knowledge of Material Things</i> | | | 294 |
| 15. <i>Concerning Ideas</i> | 91 | 58. <i>Of the Mode of the Angelic Knowledge</i> | | | 300 |
| 16. <i>Concerning Truth</i> | 94 | 59. <i>Of the Will of the Angels</i> | | | 306 |
| 17. <i>Of Falsity</i> | 100 | 60. <i>Of the Line or Direction of the Angels</i> | | | 310 |
| 18. <i>The Life of God</i> | 104 | 61. <i>Of the Production of the Angels in the Order of Natural Being</i> | | | 314 |
| 19. <i>The Will of God</i> | 108 | 62. <i>Of the Perfection of the Angels in the Order of Grace and of Glory</i> | | | 317 |
| 20. <i>God's Love</i> | 119 | 63. <i>The Malice of the Angels with Regard to Sin</i> | | | 325 |
| 21. <i>The Justice and Mercy of God</i> | 124 | 64. <i>The Punishment of the Demons</i> | | | 333 |
| 22. <i>The Providence of God</i> | 127 | Treatise on the Work of the Six Days | | | |
| 23. <i>Of Predetermination</i> | 132 | | | | |
| 24. <i>The Book of Life</i> | 141 | | | | |
| 25. <i>The Power of God</i> | 143 | | | | |
| 26. <i>Of the Divine Happenings</i> | 150 | | | | |
| Treatise on the Trinity | | | 65. <i>The Work of Creation with Regard to Creatures</i> | | |
| 27. <i>The Procession of the Divine Persons</i> | 153 | | | | |
| 28. <i>The Divine Relations</i> | 157 | | | | |
| 29. <i>The Divine Persons</i> | 161 | | | | |
| 30. <i>The Plurality of Persons in God</i> | 167 | | | | |
| 31. <i>Of What Belongs to the Unity or Plurality in God</i> | 171 | | | | |
| 32. <i>The Knowledge of the Divine Persons</i> | 175 | | | | |
| 33. <i>Of the Person of the Father</i> | 180 | | | | |
| 34. <i>Of the Person of the Son</i> | 185 | | | | |
| 35. <i>Of the Image</i> | 189 | | | | |
| 36. <i>Of the Person of the Holy Ghost</i> | 190 | | | | |
| 37. <i>Of the Name of the Holy Ghost—Love</i> | 197 | | | | |
| 38. <i>Of the Name of the Holy Ghost as Gift</i> | 200 | | | | |
| 39. <i>Of the Persons in Relation to the Essence</i> | 202 | | | | |
| 40. <i>Of the Persons As Compared to the Relations or Properties</i> | 213 | | | | |
| 41. <i>Of the Persons in Reference to the Notional Acts</i> | 217 | | | | |
| | ix | | | | |

figure 4.3
 Table of Contents for Volume I of Thomas Aquinas' *Summa Theologiae*. Note the division into Parts, Treatises and Questions. Questions are divided into questions, responses, objections and conclusions building up larger conclusions from smaller ones. Compare this structure to the gothic cathedral (figure 5.6)

divine and corporeal.

The cathedral at Chartres demonstrates Panofsky's thesis that the architecture of the cathedral is structured identically to Aquinas's *Summa*. The main structural supports subdivide numerous times, like a table of contents, relating the concepts of each part to a larger whole. The sculptures, stained glass, and spaces organized by these elements are all the various elements of our world, sorted, organized and arranged in a unified manner. The architecture becomes a symbolic device for relating the everyday world, to the narrative of sacred time.

Within the space of the Gothic cathedral, the world is a unified structure, as the sacred acts as a model of the cosmos. Entering the cathedral therefore, is not crossing an edge into another narrative. Rather it is entering a microcosm which illuminates the order of the wider world. The experience of entering and departing the Gothic cathedral is a continuous journey within sacred time. There is no edge, as the architecture points to, and reflects the quotidian. This structure articulates the way in which the Gothic cathedral links the material and divine within sacred time.

In contrast, a contemporary division of sacred and everyday time divides the material from the divine. The Gothic cathedral, as interpreted by Panofsky, suggests that occupying the edge in contemporary sacred space consists in finding new methods of relating sacred time to our contemporary condition. Finding the material in the divine, and giving structure to the numinal consists in generating thresholds which find common ground between the sacred and quotidian.

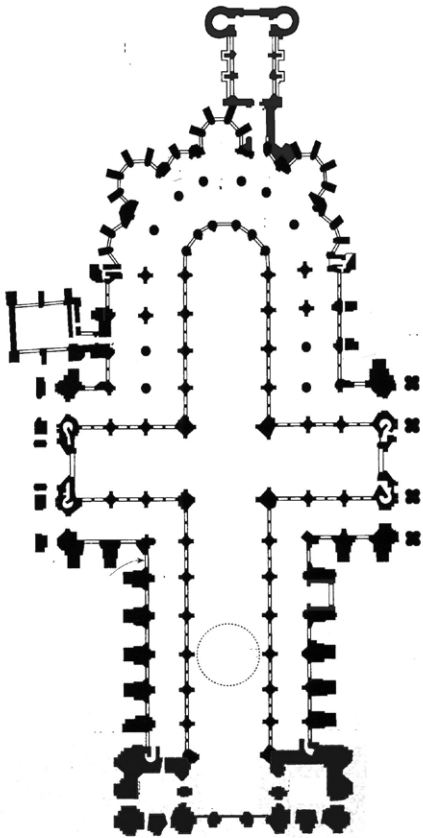

figure 4.4.1 (above)
Plan of Chartres Cathedral



figure 4.4.2 (right)
Ceiling of Chartres Cathedral. Compare the architectural structure to the structure of Aquinas' *Summa Theologica*, (figure 4). Major structures divide and subdivide organizing narratives contained in the statues and stained glass. A medieval cosmology including both the sacred and quotidian is organized.

v. New Sacred Spaces

THE ARCHITECTURAL EXPLORATION of thresholds which can connect the sacred and quotidian is concerned with finding structures and experiences which relate these two temporalities – ie. how the experience of the sacred compares to the experience of the quotidian and vice versa. As opposed to the dichotomous, hierarchical, or nihilistic relationships between the sacred and quotidian explored in part one, a reciprocal relationship holds the possibility of creating edge conditions which bridge between. Reciprocity implies a mutual relationship and action. Two projects, Herz Jesu Kirche in Munich (Church of the Sacred Heart) and St. Gabriel's in Toronto, illustrate potential architectural expressions of this relationship.

Completed in 2000, the church of Herz Jesu by architects Allmann, Sattler and Wappner consists of a series of material layers transitioning the worship space to its surrounding neighborhood. Located in an urban neighborhood in Munich Germany, the church acts as a series of filters for light and movement which alter at different programmatic areas of the church, and different times of day. The effect is to manipulate the edge of the sacred space and build thresholds into the surrounding fabric.

The building consists of two inset volumes. The first is enclosed by wood slats and houses the liturgical space. A second volume of light steel framing and structural glass surrounds it. Each volume filters light. The 2000 vertical slats of the inner volume increase in separation as they approach the altar, directing light and increasing the quantity of light towards the focus of worship. Inversely, the exterior volume of glass increases in opacity as it approaches the altar area allowing a milky light, but eliminating view of the religious functions from outside.

This interplay of transparencies differentiates between light as a sensual experience, and light as a visual connection. Gradually the role of light moves from being one of connection and invitation towards the entrance to one of divine symbolism towards the altar. As the day progresses, the church acts as a vessel to collect light, and come nightfall, the church dispenses light into the surrounding community. The volumes work together to modulate the experience of light generating relationships with the everyday.

This transition between the sacred space and the street is facilitated by a continuous



figure 4.5
elevation of Herz Jesu Church showing the transition in the opacity of the glass.

figure 4.6 (top, across)
plan of Herz Jesu Church, Munich Germany.

figure 4.7 (bottom, across)
A large portal at the entrance swings out to include the forecourt into the sacred space.

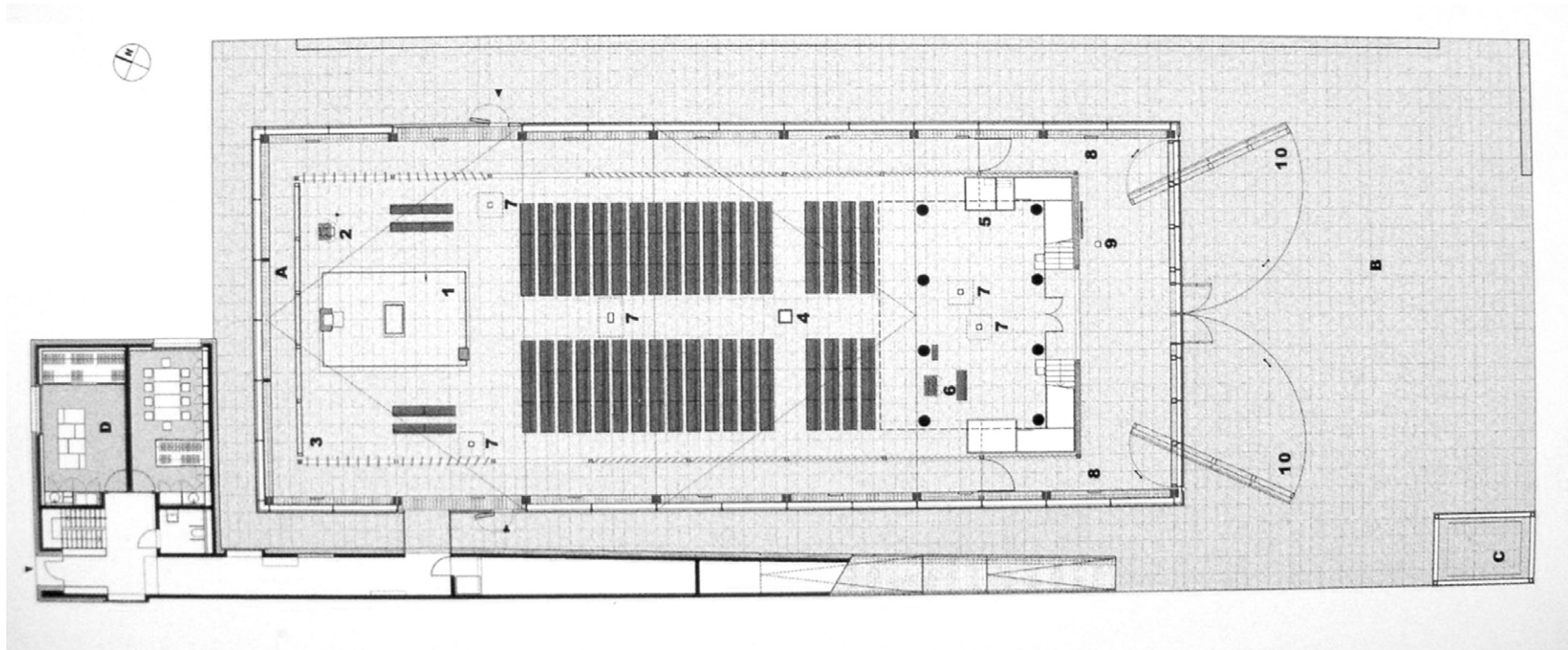

limestone flooring which extends from the interior to the forecourt. A slight differentiation is made in the finish of limestone flooring at the entrance becoming rough outside rather than smooth. This material continuity passes through the layers of the building, which are each individually articulated to transition the viewer between spaces.

The exterior facing the forecourt consists of two fourteen-metre high mechanically-operated panels which can swing open in a welcoming gesture and further connect the worship space to the forecourt and the surrounding city. The forecourt becomes included in the worship space and vice versa. The glass panels are physically massive, mechanical, and earthly, decorated with a silk screen of densely patterned blue nails. The texture of this plane is a counterpoint to the end wall of the worship space, where the warp of a fourteen-metre high gilded metal curtain reveals a massive cross. Vertical light from a skylight reveals the cross embedded in the metal weaving. Both surfaces represent a threshold: the former reflects the weight of the mortal life, and the latter the promise of the divine. Each acts to give definition to the journey towards the altar and away from it. The breach between the two boxes of wood and glass hosts the stations of the cross, suggesting the cyclical path of prayer that transitions between.

figure 4.8 (this page)

The gilded metal curtain reveals a large cross in the weft of its weave. Lights from a skylight above highlight the cross. Because of the semi-transparency of the curtain, the cross appears to be made of light.

figure 4.9 (top, across)

the exterior volume of the church is completely enclosed by glass of varying transparency.

figure 4.10 (middle, across)

levels of transparency filter light allowing a transition between the sacred and quotidian.

figure 4.11 (bottom, across)

the pattern of blue nails silkscreened onto the massive glass portals at the entrance.

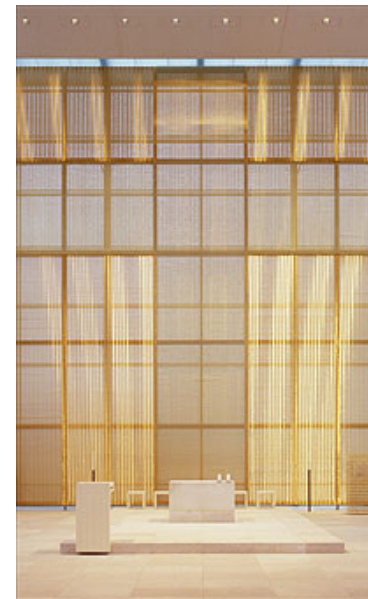

In the case of St. Gabriel's Church (2006) in Toronto Canada, ecology and sustainability are seen as a cosmological narrative which connect the liturgical ritual to a garden and the city beyond. Designed by Roberto Chiotti of Larkin Architects, the church became the first church in Canada to receive a silver certification under the Leadership in Energy and Environmental Design (LEED) rating system, an international standard for measuring 'green' design. The church articulates the 'Eco-Theology' of theologian Thomas Berry, a member of the Passionist Order, who own and operate the church. Eco-Theology emphasizes the role of covenant between God and life as the foundation of creation. A human relationship with the divine relies on a stewardship of creation. The articulation of this theology in the architecture of St. Gabriel's emphasizes direct relationships between the sacred and nature. This relationship attempts to expand sacrality beyond the edges of the church, incorporating an awareness of the everyday into the act of worship.



The church responds to this narrative in both its organization and expression. Organized to take maximum advantage of the sun, the south face of the worship space is opened to natural light through a full height glass wall. Along with a sizable overhang and the remaining three concrete walls, the glass provides light and controls heating/cooling for most of the year. The building is sited to take advantage of local transit routes and an underground parking lot means that most of the site is given over to a garden. Extending from the south face of the church, the garden is oriented to the worship space visually uniting the two.

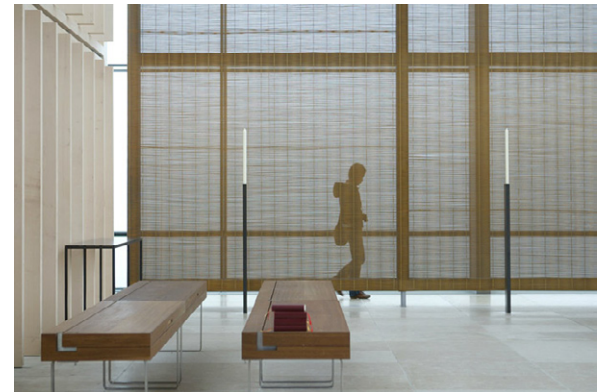

Access to the church is provided on the east-west access, perpendicular to the axis of ritual. Parishioners pass through an exterior piazza, an elongated narthex and enter the sanctuary from the side. Antiphonal seating reorients the axis of worship from the east-west direction of entry, to the north-south.

By orienting the liturgical processions along the north-south axis, the ritual always travels between the tabernacle and the exterior garden. A series of liturgical stations from the altar, ambo, and baptismal font stretch the rituals of mass out between the representation of Christ and the garden. The experience is to orient the worship to a connection between the sacred and everyday.

This narrative is emphasized in the construction of the church which tries to exclusively use low-environmental-impact materials⁷. A living wall in the narthex area highlights the

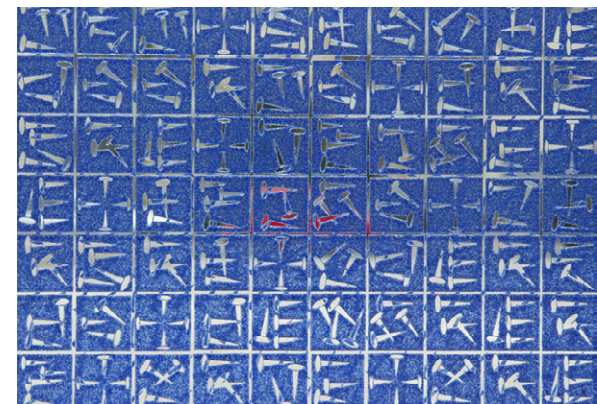

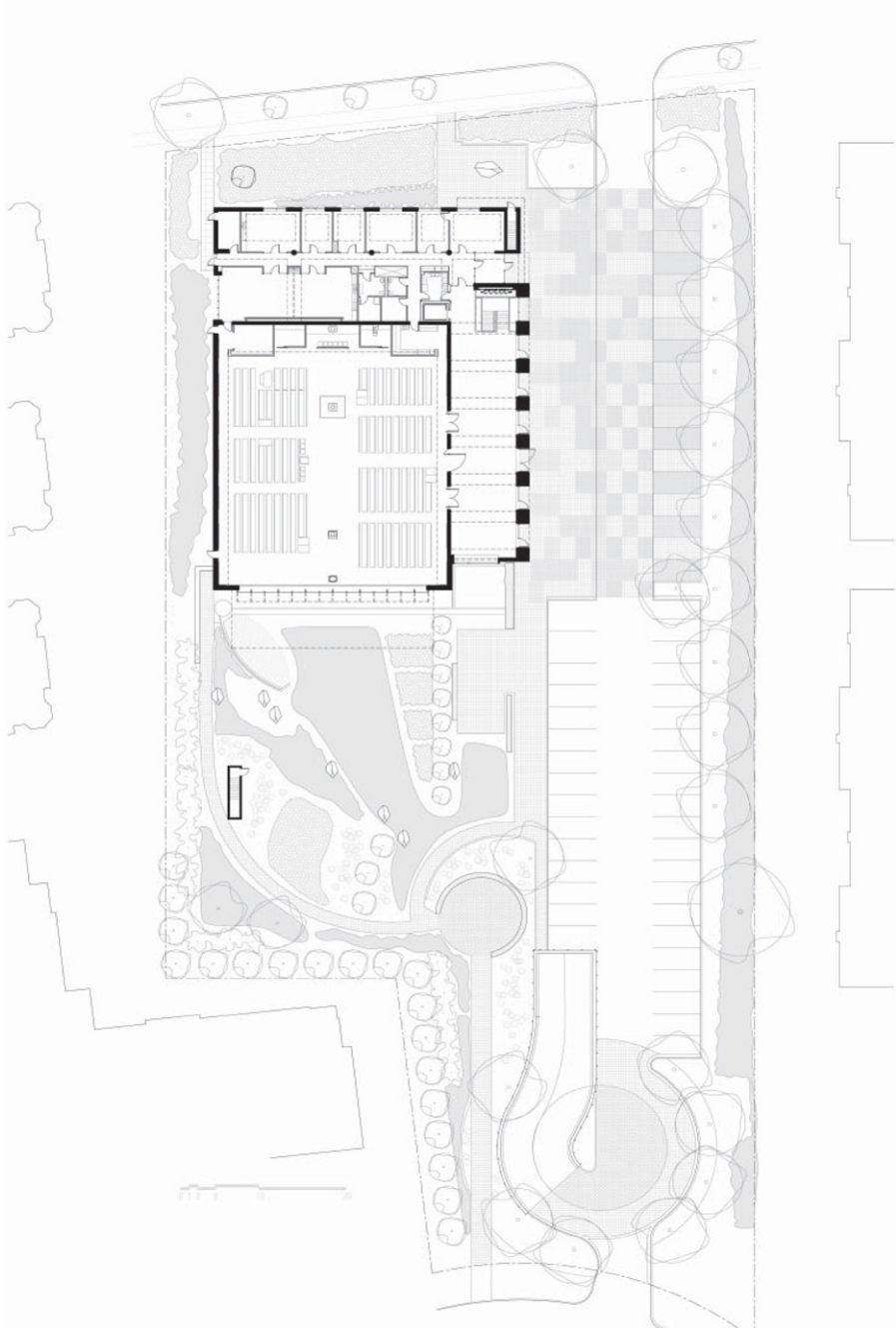

'green' agenda of the architecture and helps to clean the air and control humidity. Similarly, the building systems including, water saving fixtures, irrigation system, high-efficiency mechanical systems, and passive climate control methods where possible are used. These mundane aspects of the building emphasize the ecological narrative of the church reinforcing the architectonic language in the technical reality of the structure.

This narrative tries to link the time of the sacred to the time of the everyday through the principle of stewardship. An ecological imperative shapes the orientation and expression of the liturgy. The liturgical movements along the north south axis emphasize this connection between the sacred space, the garden, and the planet. Worshiping within this building, and along this axis is a process of connecting the sacred to the quotidian.

Herz Jesu, and St. Gabriel's illustrate new possibilities in the language of contemporary sacred architecture. An analysis of these churches reveals the possibility for architecture to occupy the edges of contemporary sacred space. These thresholds enrich our experience of the sacred by confronting its edges and proposing reciprocal relationships between the sacred and quotidian. They point to the communicative role of phenomenology and narrative as tools to articulate content beyond the abstract and personal sensation of the numinous.

The thresholds at Herz Jesu are driven by a focus on sensation. Through attention to sensory qualities such as light/dark, opaque/transparent, smooth/rough an experience of transition is created. The modulation of surfaces helps to experientially unite the two spaces. Surfaces such as the limestone flooring moves continuously between spaces. Similarly the density of wood slats and the frosting on the glass gradually transitions from quotidian to sacred. Material surfaces, their texture, colour or transparency, generate a threshold. Surfaces such as the patterned glass of the gateway, or the woven metal fabric behind the altar use materiality to evoke sensations. Passing through these layers in time evokes a slow transition which overlays the sacred and quotidian as opposed to dividing them.

The church does not suggest any particular theology, or try to explain the relationship between sacred and quotidian. The careful manipulations of light however, reveals an open-ended narrative of the similarities and differences of outside/in. Consistently, light is used as a tool to express connection and relationship. The changing property of light across the building expresses the nature of these relationships. Towards the forecourt, where view and connection is made possible by openness and transparency, light is used as a visual connection.



*figure 4.12 (left, across)
Plan of St. Gabriel's Church, Toronto, Canada*

*figure 4.13 (top right, across)
A massive south facing glass wall controls heating and lighting, connecting the sanctuary to the garden.*

*figure 4.14 (bottom right, across)
antiphonal seating focuses the ritual on liturgical stations which connect the tabernacle to the garden.*

*figure 4.15 (top, this page)
interior of the sanctuary*

*figure 4.16 (bottom, this page)
the narthex area contains a living wall which controls air quality and underscores the ecological narrative.*

Towards the altar, where sensory qualities of mystery are made possible by filtering, light is used as a divine sensation. This narrative emphasizes the similarities and differences in the sacred and quotidian through what might be described as a theology of relationship in light: light acts as a bridge for the worshiper both towards the divine and towards their community.

In contrast, the materiality at St. Gabriel's is less evocative. The exposed concrete and drywall of the sanctuary is fairly stark in comparison to the rich surfaces at Herz Jesu. Materiality still forms a key aspect of a threshold however. Materials such as the exterior limestone embedded with the fossils of ancient sea crustaceans strengthens the theological narrative of the church. The recycled or re-used materials do not necessarily evoke sensations in their surfaces, but are key elements of the experience. Materiality acts to support the ecological narrative which conceptually bridges the sacred and quotidian.

This narrative is strongly expressed in the orientation and liturgical organization of the church. St. Gabriel's relies on eco-theology as a conceptual structure which links an understanding of the sacred with the natural world. This structure acts as a way to transition the time of the sacred to the time of the everyday. The sacred is understood in the context of stewardship over creation. It is emphasized through the organization of the liturgical stations and the equivalence of the worship space and the garden. This conceptual structure is similar in nature to the structure of medieval thought which generated the form of the gothic cathedral. While more limited in scope, the structure of St. Gabe's tries to express a common time of the sacred and quotidian in the narrative of ecological principles.

The interpretive structures for reading sacred space explored in part one help to reveal the nature of an inbetween

time in St. Gabriel's and Herz Jesu. Both these churches articulate the structure, aesthetic impact and relationships of a threshold.

St. Gabriel's strongly relies on the temporal structure of eco-theology which sees sacred time fulfilled in the everyday interactions with natural systems. Herz Jesu articulates a more open-ended narrative which organizes sacred and quotidian time as two experiences connected by the common medium of light.

Both St. Gabriel's and Herz Jesu create strong connections between the sacred and quotidian in one's movement through these spaces. Herz Jesu is organized along an axis which experientially extends the sacred out into an open forecourt. Materiality and program shift along this axis. Similarly, St. Gabriel's is strongly oriented on an axis which connects the liturgy to an exterior garden. The experience of worship draws one into this tension.

Finally, both churches express threshold in how they respond to, and change in time. St. Gabriel's is carefully tuned to the time of the now, relying on sunlight and daily climate cycles for light, heat and water. The building expresses a deep attachment to the changing moments of the everyday. Herz Jesu participates in a daily cycle of collecting and distributing light, expressing an inverse but reciprocal relationship to the quotidian patterns of the everyday.

In both of these projects, one can read a focus on thresholds between the sacred and quotidian. The unique temporalities of the sacred and quotidian are related through the time of the threshold. While neither inside, nor outside, the time of threshold relates the two times of sacred and quotidian, seeking to find common structures, experiences or relationships. The effect is to extend the space and time of the sacred outwards, and to allow the space and time of the everyday to come inwards.



figure 4.17



figure 4.18

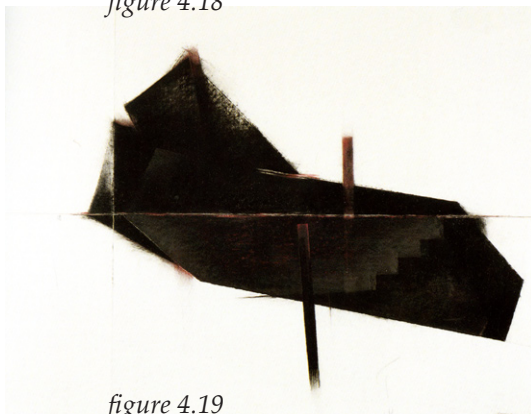

figure 4.19

v. Towards a Temporality of Thresholds

CROSSING THE THRESHOLD between the time of the sacred and the time of the secular creates opportunities for overlap. Herz Gesu Kirche and St. Gabriel's Church articulate connections and interaction between the church and city. This overlap points towards a middle zone which challenges both an understanding of the church and the city in contemporary architecture. Moments which connect the sacred and quotidian suggest that architecture can negotiate these currently contrasting structures of my reality: that there is a temporal structure which bridges the sacred and quotidian. The threshold provides the key to the transition and connection between distinct temporal orders. As a zone, it constitutes the spatial condition for the meeting and dialogue between these two orders. The temporality of the threshold is neither the structured time of the sacred, or the indeterminate time of the quotidian. It suggests a temporality of threshold.

I imagine a new theology of the everyday that defines this temporality of threshold. A division between sacred and quotidian denudes both by ignoring their common goal of reflecting the fullness of 'being' which seeks both divine and mortal. A theology of the everyday is one which describes and encompasses the fullness of my reality and forms the basis for a new experience of the church and city. Between the sacred and quotidian lies the possibility of a new space, which seeks to relate the divine with the everyday. Three reflections begin to define my understanding of a theology of the everyday:

- a. an architectural language of changing connections
- b. spaces of analogous experiences
- c. an architectonic interpretation of time

By reflecting on these themes in relation to the design project in part three, several key relationships arise in the definition of a temporality of threshold.

a. an architectural language of changing connections

Experiencing a threshold between the sacred and quotidian involves moving between two poles for me, always shifting between stable eternal truths and the temporal situation in which I live out these truths. I recognize that neither revelation nor reason can fully describe this journey. Between the sacred and quotidian is somewhere between the stable reality of a sacred time, and the ever changing situations of the moment. But to what extent does the sacred contribute to an understanding of reality, and are there some experiences known only by reason in the moment, some only by the eternal truths of faith and some by either or both?

As a way to explore this idea, I began to imagine an architecture which acts to preserve both the rigid structures of revelation and the open structures of reason⁸. A potential architectural language tries to extend the variety and type of connections. At Herz Jesu, more ineffable experiences are articulated by an opaque glass and diffuse light, while the direct encounters within the narthex are articulated by a transparency. This architectural vocabulary begins to establish a language of thresholds by looking at the various ways



figure 4.20

direct and indirect connections help in defining the relationship between the divine and everyday.

This process resembles the design exploration of the north wall (figure 4.20) at St. Basil's Church. Filtering, opaque, and transparent materials allow a variety of interactions between the church and street, overlaying experience and narrative onto each other. One experience of the city, may begin to correlate with a moment within the ritual of mass, combining their significance. The strategy for this threshold is to overlay various types of thresholds - visual, circulatory, or experiential (figure 4.21).

This interplay suggests a field of possible connections which relate the sacred and quotidian. Thresholds act as bundles of connections (figure 4.22) which provide a variety of interaction between two spaces. Providing the possibility for direct and indirect encounters allows a layering of experience. Theologically, this suggests the full range of human experience, from faith to reason, which helps negotiate between the sacred and quotidian.

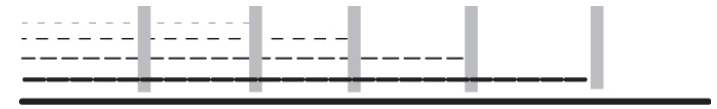

figure 4.21

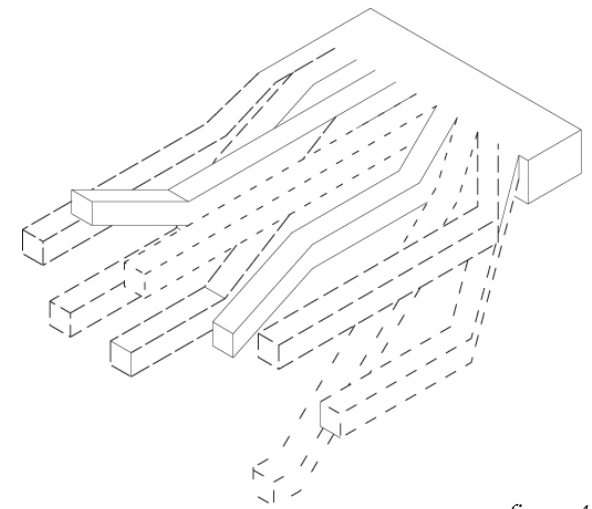
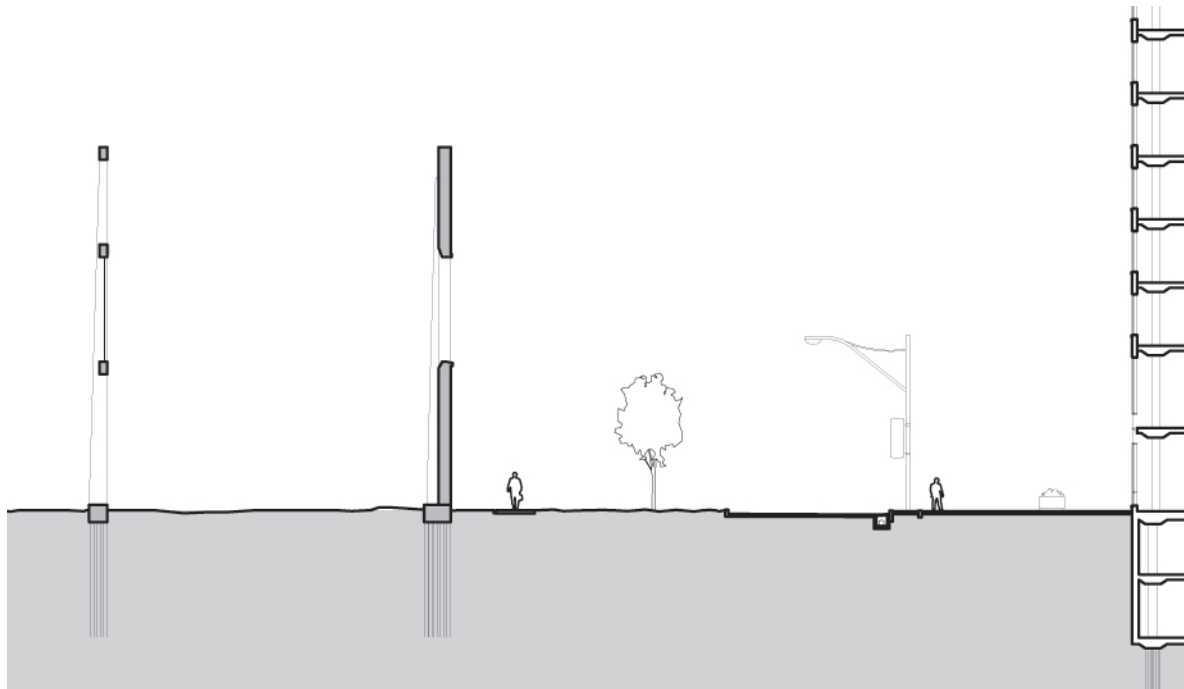

figure 4.22



b. spaces of analogous experiences

The division of sacred and quotidian creates a tension between two times. I am restless in one or the other, always wanting to move between, pursuing some sort of equilibrium. I imagine the possibility that the structured time of the sacred might occasionally overlap with that of the quotidian. Like the two hands of a clock which once every sixty minutes align, or the cycle of the eclipse, I seek to rest briefly in that moment of conjunction.

St. Gabriel's achieves this conjunction in the idea of eco-theology. The scale of time reflected in the stewardship of nature finds resonance in both a sacred and quotidian narrative.

Exploring this idea, I became interested in the architectural setting of the Donovan Collection (fig. 4.17-19), one of Canada's largest collections of contemporary Canadian art.⁹ Throughout the corridors and common areas of Odette Hall, works have been

gathered by its curator Fr. Daniel Donovan which are not necessarily religious but which reflect a common theme: "Most of the works have what I would describe as a spiritual quality. Some of them develop traditional religious images or symbols but do so in a modern way."¹⁰ The display of these works acts to heighten a sense of overlap. Works in the 'xerox room' for instance discuss the role of language and the reproduction of words and text. Works in the 'coffee room' express serenity and suggest what Donovan sees as a 'chapel.' In each instance the artwork and its setting amplifies moments of connection when the ineffable and the everyday meet to reveal the depth of meaning present. Interacting with these moments can begin to define thresholds in the built fabric.¹¹

This process is similar to that used in the design exploration of the ramp at St. Basil's (figure 4.23). The ramp provides access to

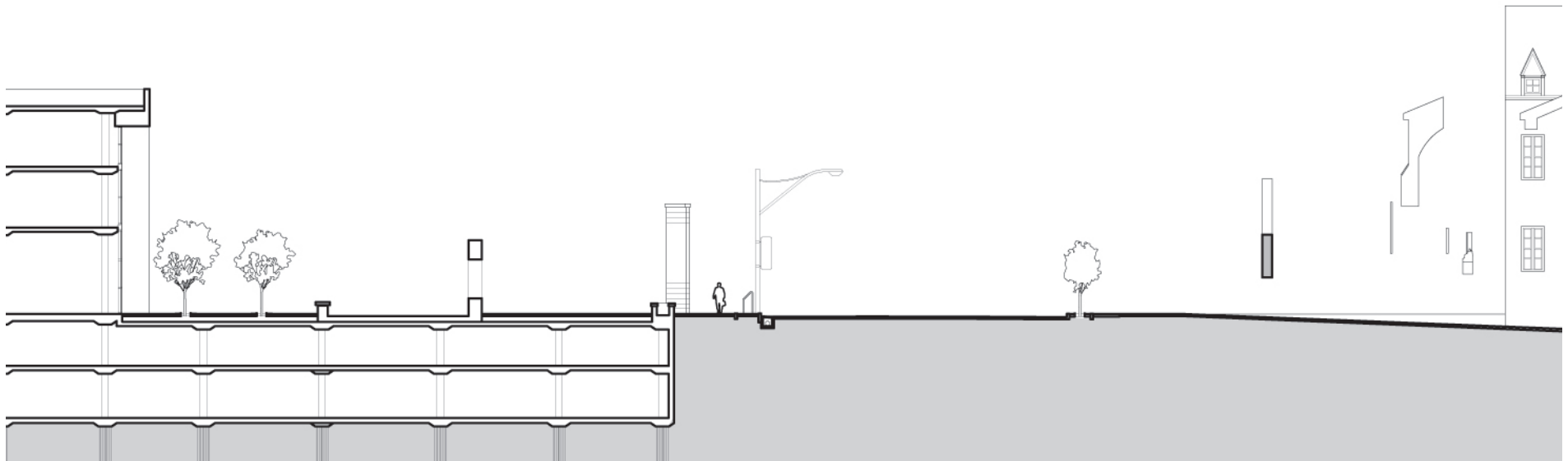

the church hall which acts as both a service space for the city, as well as an expression of the sacred. In this moment, two divergent zones find a co-habitation in a particular program. This program becomes an intersection of the vertical and horizontal axes. The strategy for this threshold is to find moments of intersection which resonate in both the time of the sacred and quotidian (figure 4.24).

These intersections express the role of thresholds in defining common ground. Individual moments pierce through divisions, linking the sacred and quotidian in specific instances (figure 4.25). The sacred is often manifested in various places outside the sanctuary, including the home, places of gathering, or the geography of the landscape¹². In this sense, all architecture is involved in the generation of sacred space. Moments which find an alignment between the quotidian and sacred narratives give added significance to those experiences.

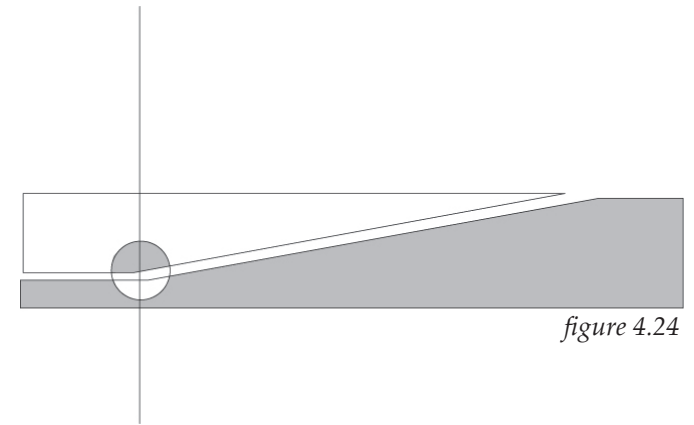

figure 4.24

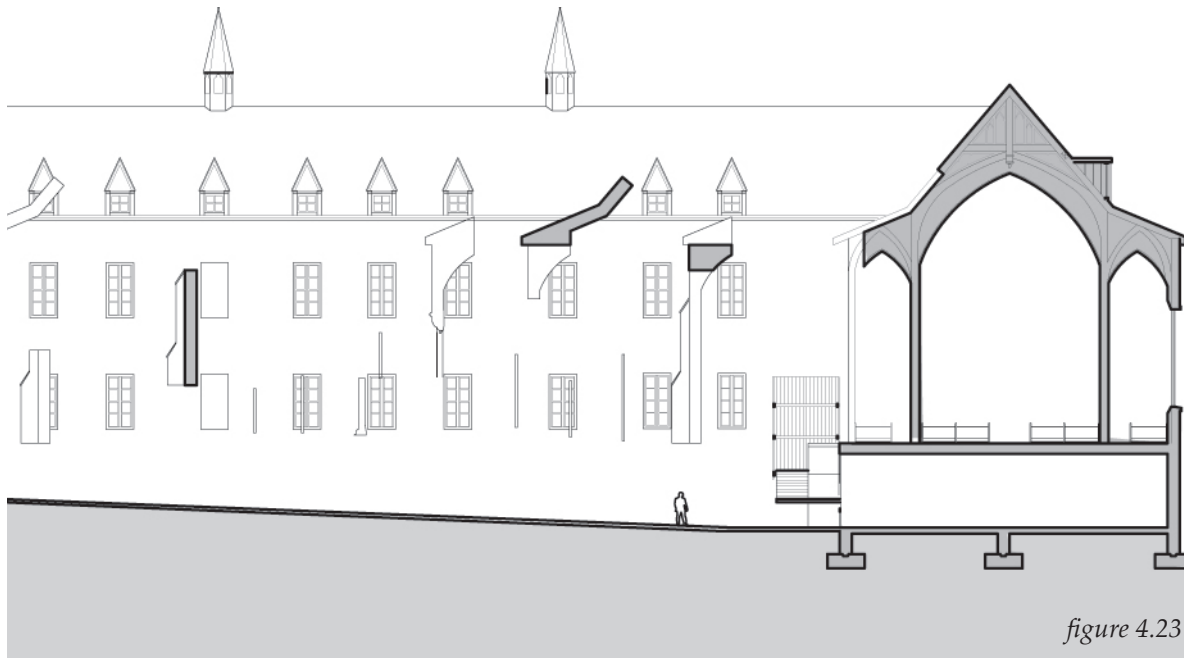

figure 4.23

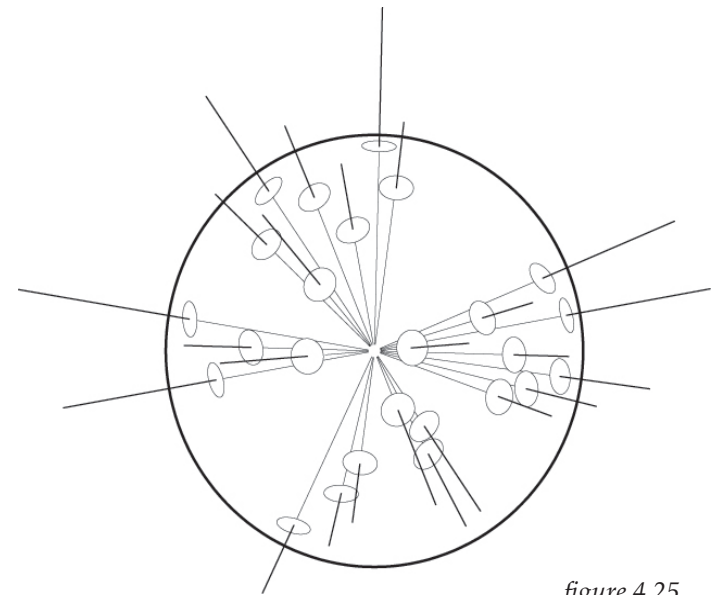

figure 4.25

c. an architectonic interpretation of time

The term threshold comes from early words used to describe the stone of the doorsill at the entrance to a room or building. The term implies a crossing between distinct zones, but refers to that third, momentary space of 'inbetween.' Temporally the space of the threshold exists only in the sliver of time between two spaces, neither in nor out. For a brief moment, you are neither in one space nor the other but in some amalgam of both. The architecture of the threshold therefore is perhaps a temporal one. It exists in the act of moving between. It is not a static structure of time, or an indeterminate space of anytime, but moments along a constant journey. The beating wings of a hummingbird sometimes appear still, moving so quickly as to appear simultaneously up and down, suspending the bird in the air. I believe moments of overlap between the sacred and quotidian are similar, moments of pause on the continuous journey between.

This idea is explored in the design of the East Wall at St. Basil's church (figure 4.26). The architectural elements do not define a new zone, but moving through it, begins to open up and transition between two zones. The effect is to delay the moment of crossing, and provide space for encountering and exploring this transition. We typically imagine architecture as a



figure 4.26

static object, but in its inhabitation it provides moments which shift and change (figure 4.27). Both the object itself (cycles of day/night) and our experiences (movement through) change in time.

This idea of threshold recognizes the temporal space – a space as influential as the constructed space (figure 4.28). The act of moving through and transitioning, provides an experience of translation. Fragments of light and sound, blur together creating a temporary overlap. Within this time, there exists the possibility of observing both spaces, and inhabiting a space between.

In time, the theology of the everyday acquires definition. I believe it is in the act of moving in time that architecture can best express this dynamic. Living out the varying applications of seemingly static truths needs not deny either the structures of belief, or the varying possibilities of moment. Instead, always moving between these, both are enriched. Constructing the various experiences of crossing between sacred and quotidian, I begin to occupy the border.

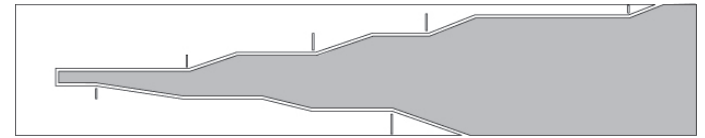

figure 4.26

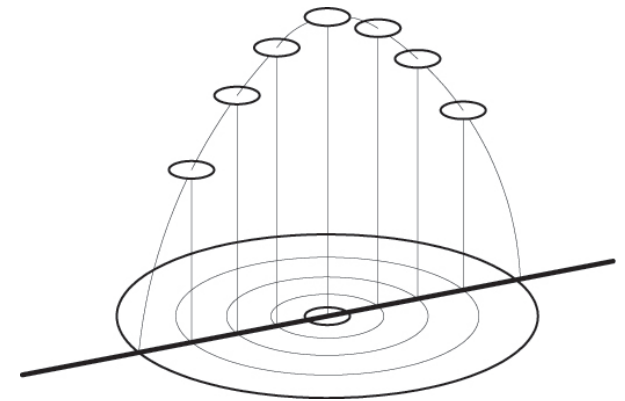
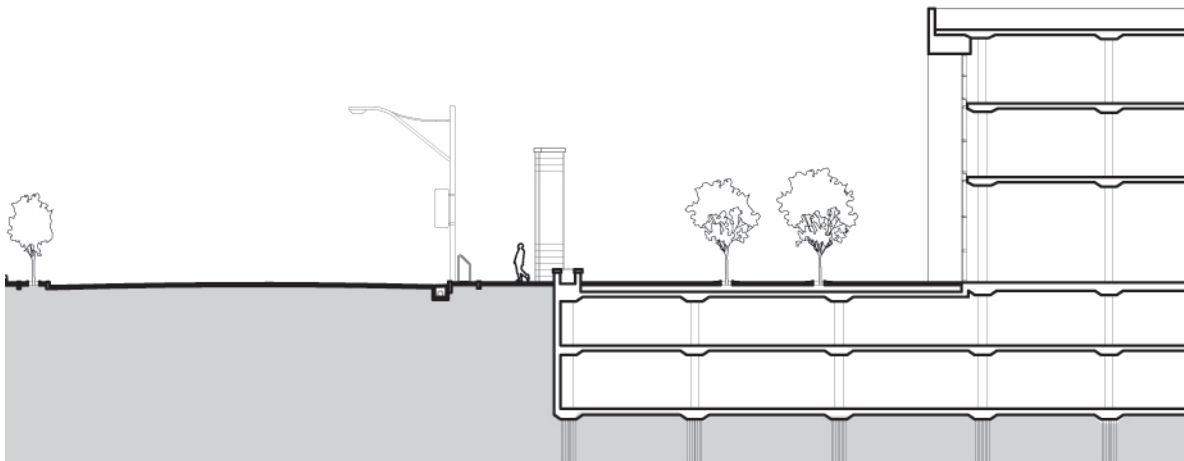

figure 4.27



Endnotes

INTRODUCTION

- 1 Paul Ricoeur, "Architecture and Narrative" (paper presented at the 19th Triennale di Milano Conference, Identity and difference: integration and plurality in today's forms. Milano: Electa, 1996) 64.
- 2 Paul Ricoeur, "Architecture and Narrative," 72.
- 3 Dalibor Vesely, *Architecture in the Age of Divided Representation: the question of creativity in the shadow of production* (Cambridge, MA: MIT Press, 2004).
- 4 Martin Heidegger, "Building Dwelling Thinking," In *Basic Writings from Being and Time To The Task of Thinking*, ed. David Farrell Krell (New York: Harper & Row, 1977) .
- 4 Raymond E. Brown, Joseph A. Fitzmyer and Ronald E. Murphy, eds., *The New Jerome Biblical Commentary* (New Jersey: Prentice-Hall, 1990) 620.
- 5 Achtemeier, *The HarperCollins Bible Dictionary*.
- 6 Louis Nelson, ed., *American Sanctuary: understanding sacred spaces* (Bloomington: Indiana University Press, 2006) 2. Nelson's collection of essays covers a broad range of sacred spaces from churches to junkyards. The collection highlights the multitude of ways the sacred is informing the built environment. These essays demonstrate the ongoing fascination with the sacred in contemporary dialogue.
- 7 Nelson, ed., *American Sanctuary: understanding sacred space*, 11. Nelson cautions against the idea that architects somehow generate the sacred in pure form. Rather the sacred reflects a multitude of voices.

PART ONE

- 1 Paul J. Achtemeier, ed., *The HarperCollins Bible Dictionary*, ed. with the Society of Biblical Literature (San Francisco: HarperSanFrancisco, 1996)
- 2 Ibid.
- 3 James L. Mays, ed., *The HarperCollins Bible Commentary*, ed. the Society of Biblical Literature (San Francisco: HarperSanFrancisco, 2000) .956. The money changers listed in all three of the synoptic gospels would have been used for converting Greek or Roman money into Jewish or Tyrian coins for temple donations as well as local commerce.
- 8 Lindsay Jones, *The Hermeneutics of Sacred Architecture: experience, interpretation, comparison* (Cambridge, MA: Harvard University Press, 2000). Lindsay Jones describes this process as "ritual-architectural-events". This suggests that the sacred is formed primarily in time through inhabitation as opposed to construction.
- 9 Richard Kieckhefer, *Theology In Stone: church architecture from Byzantium to Berkeley* (Oxford: Oxford University Press, 2004) 135. Kieckhefer divides christian sacred space into three types: classic sacramental, classic evangelical, and modern communal. St. Basil's falls into the category of classic sacramental (earlier versions of the church included antiphonal seating around the altar, which resembles aspects of the communal within a distinct zone).

- 10 This is the key function of Christian sacred space. As the incarnation manifests the sacred in time and not place, the role of sacred space is to model the material caught up in divine time, not as a resting place of the divine.
- 11 Rudolph Otto, *Idea of the Holy; an inquiry into the non-rational factor in the idea of the divine and its relation to the rational*, trans. John W. Harvey (London : Oxford University Press, 1958), 6.
- 12 Kilde's hermeneutic method introduced in this article is expanded further in her recent book *Sacred Power, Sacred Spaces (2008)*
- 13 Mircea Eliade, *Sacred and the Profane: the nature of religion*, trans. Willard R. Trask (New York: Harper & Row, 1961) 26.
- 14 Mircea Eliade, *Sacred and the Profane*, 25.
- 15 Mircea Eliade, *Sacred and the Profane*, 30.
- 16 Nelson, ed., *American Sanctuary*, 3.
- 17 Plato's *Timaeus* connects the idea of physical beauty as a reflection of the true essence of an object. Beauty therefore points to truth, and Plato's text underscores a western association between beauty and the divine.
- 18 Kieckhefer, *Theology In Stone*, 98. quoting Sovik
- 19 Jeanne Kilde, "Reading Megachurches" In *American Sanctuary: understanding sacred spaces* (Bloomington: Indiana University Press, 2006) 230.
- 20 Kilde, "Reading Megachurches," 241.
- 21 Many structures act to reify similar political, social or cultural ideals as sacred space including museums, civic centres and public buildings. Sacred space uniquely acts to link this to an awareness of the sacred.
- 22 Otto, *Idea of the Holy*, 10
- 23 Otto, *Idea of the Holy*, 13,19,23 Otto deals with each of these three individually.
- 24 Otto, *Idea of the Holy*, 60.
- 25 Otto, *Idea of the Holy*, 66
- 26 Eliade, *Sacred and the Profane* 10. In order to demonstrate spatial non-homogeneity Eliade invokes Exodus: "Draw not nigh hither" says the Lord to Moses; "put off they shoes from off they feet, for the place whereon thou standest is holy ground"
- 27 see bibliography for a full list of recent churches

PART TWO

- 1 Mays, ed., *The HarperCollins Bible Commentary*, 961.
- 2 Ibid.
- 3 Brown, et al., *The New Jerome Biblical Commentary*, 954. ie. judg 11:12; Kgs 17:18, Hos 14:8,

- 4 Gerard Bouchard, Charles Taylor, *Building the Future: A Time of Reconciliation* (Quebec, Canada: Gouvernement du Quebec, 2008). The Bouchard Taylor commission was a report commissioned by the provincial government of Quebec to look at accommodation practices in the province. Current events had caused a public outcry in relation to accommodation practices as they relate to race, gender and religion. While the report focused on the province of Quebec, many of the conclusions draw on national laws and standards. The report reveals how accommodation is understood in Canada, especially as the sacred relates to the public.
- 5 Gerard Bouchard, Charles Taylor, *Building the Future*, 134.
- 6 Gerard Bouchard, Charles Taylor, *Building the Future*, 145.
- 7 Ibid.
- 8 Charles Taylor, *A Secular Age* (Cambridge, MA.: Belknap Press of Harvard University Press, 2007) 3. chapter 1, introduction
- 9 The concept of the flaneur suggests a radical change in the interpretation of cities. Rather than view the city as a static entity, Benjamin documented the city as he strolled through the arcades. This movement implies a wandering.
- 10 Benjamin Walter, *The Arcades Project*, trans. Howard Eiland and Kevin McLaughlin (Cambridge, MA: Belknap Press, 1999) d,1.
- 11 This dimension is determined by the width of two parked cars from the garages which exist below. The grid and layout of most buildings along Bay Street are designed to maximize possible parking.
- 12 Curtain wall forms the most prevalent surface along Bay Street. As it requires a limited number of trades to install, and is flexible because of its modularity, it provides the most economic construction material for large surfaces.
- 13 The space of the arcades were early centres of consumerism in which Benjamin saw a decisive shift to the contemporary age. The Arcades Project deals with this condition: gIt is not the economic origins of culture that will be presented, but the expression of the economy in its culture“ Benjamin, *The Arcades Project*, N1a.
- 14 Taylor, *A Secular Age*, 374.
- 15 Vesely, *Architecture in the Age of Divided Representation*, 3.
- 16 Vesely, *Architecture in the Age of Divided Representation*, 321.
- 17 Vesely, *Architecture in the Age of Divided Representation*, 3.
- 18 Dalibor Vesely, *Architecture in the Age of Divided Representation*, 241.
- 19 Pier Giorgio Di Cicco, *Municipal Mind: manifestos for the creative city* (Toronto: Mansfield Press, 2007), 14.
- 20 Di Cicco, *Municipal Mind*, 67.

PART THREE

- 1 Brown, et al., *The New Jerome Biblical Commentary*, 602.
- 2 Ibid.
- 3 Brown, et al., *The New Jerome Biblical Commentary*, 649.
- 4 Mays, ed., *The HarperCollins Bible Commentary*, 936.
- 5 Di Cicco, *Municipal Mind*, 16.
- 6 Ibid.
- 7 Di Cicco, *Municipal Mind*, 75.

- 8 Vesely, *Architecture in the Age of Divided Representation*, 15. from the greek *poiesis*
- 9 Vesely, *Architecture in the Age of Divided Representation*, 368.
- 10 Vesely, *Architecture in the Age of Divided Representation*, 373. Vesely provides the example of dining, which is not only a task requiring functional space, but is deeply rooted in a broader context that includes “conversation, direct and indirect relations with other people, specific settings, time, and so on.”

PART FOUR

- 1 Achtemeier, *The HarperCollins Bible Dictionary*, 934.
- 2 Ibid.
- 3 Brown, et al., *The New Jerome Biblical Commentary*, 608
- 4 Andre Bieler, *Architecture in Worship: the Christian place of worship - a sketch of the relationships between the theology of worship and the architectural conception of Christian churches from the beginnings to our day* (Edinburgh : Oliver & Boyd, 1965), 27.
- 5 While there is a variation of scale and detail, this general orientation remains consistent throughout medieval mapping. The Hereford map shown is fairly specific in its geographical features, other maps represent the Mediterranean as two bisecting lines.
- 6 Erwin Panofsky, *Gothic Architecture and Scholasticism* (New York: Meridian Books, 1957) 38
- 7 Including: minimizing finishes; maximizing use of locally obtained materials; use of re-cycled steel and substituting a percentage of the cement with slag; reclaimed lumber and glass for the pews and stained glass; re-use of furniture; recycled structural steel; materials and finishes of low or zero volatile organic compound (VOC) emitting products

- 8 For me, it seems that Aquinas must have struggled with this question when scribing the *Summa Theologica*. Within the text each treatise is divided into questions. Each question is then divided into objections, responses, and conclusions. The ordering of the book serves to develop each conclusion from first principles through this process of question and answer. At times these conclusions derive from observation, biblical quotation or a combination joined through inductive reasoning. The Aquinaseum (see illustration) acts as an exploration into how revelation and reason interact in Aquinas’ text.

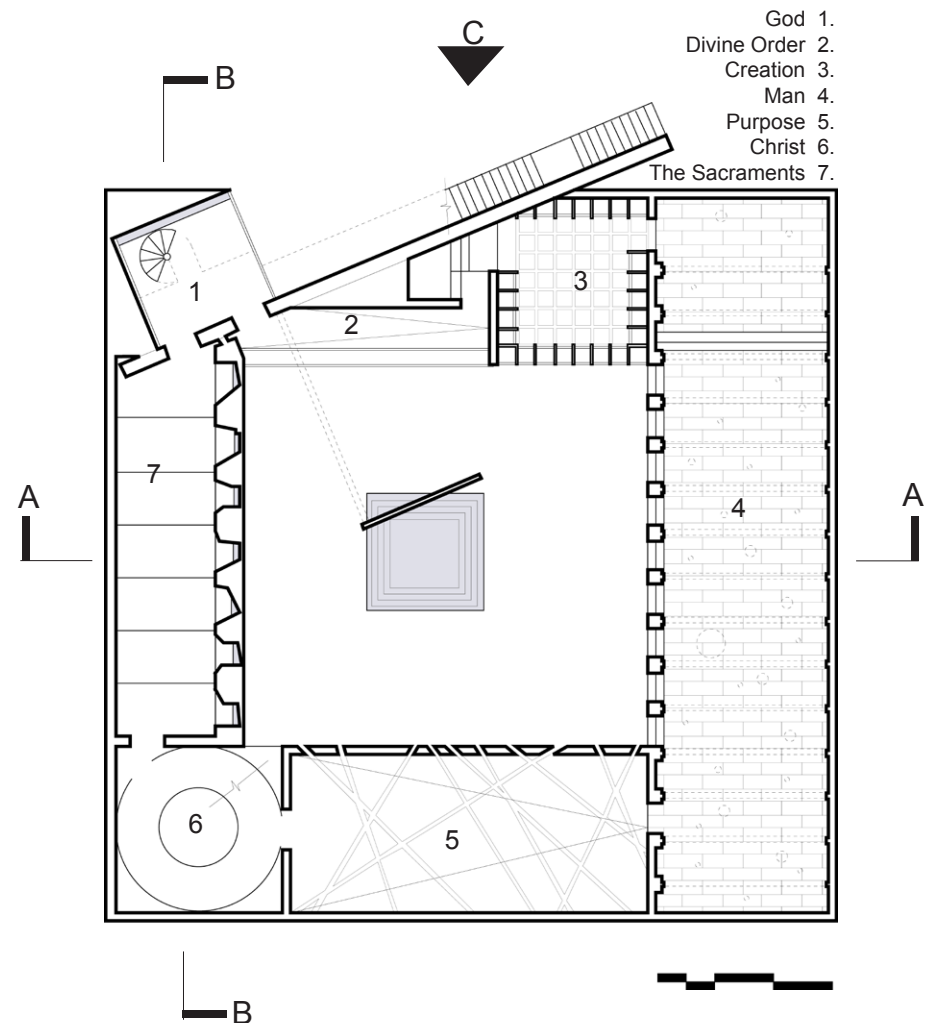

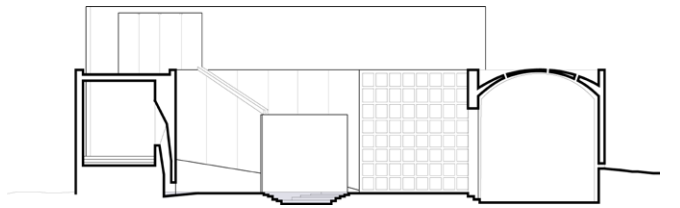

SECTION A-A

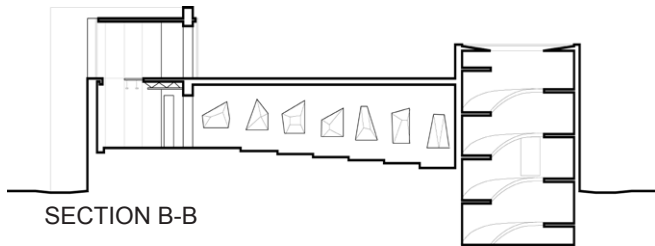

SECTION B-B

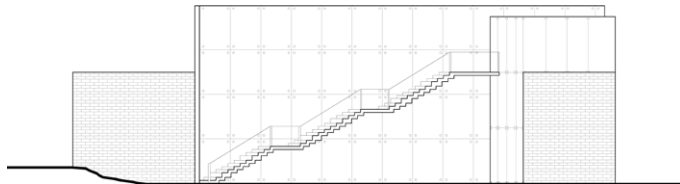

ELEVATION C



2



5

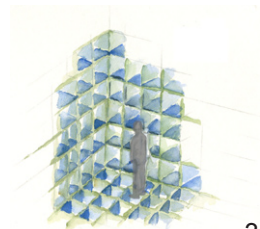

3



6



4



7

- 9 The collections home is Odette Hall, a set of offices attached to the church. The offices support the day to day operations of the community, but largely house several departments at St. Michael's University, and the University of Toronto. The variety of work centers on images and forms which express aspects of the divine in contemporary culture: "more recently art and religion have tended to go their separate ways. Much contemporary art although not explicitly religious, possesses what might be described as a spiritual quality. Art making of this kind tends to engage artists at the deepest levels of their being." These pieces, at times directly religious or not, act as signs of overlap between the spiritual and the material. They point towards the mystery which permeates and gives depth to my being. As Donovan expresses, they touch on the level of being which incorporates both divine and material.

- 10 Fr. Donovan, movie

- 11 Encountering Tim Whiten's sculpture Dwelling #5 immediately suggests an architectural setting. The form of the 6"x6"x9" solid block of cast glass suggests the generic house (see photographs). The texture of the glass is rough and earthen in contrast to its lightness and transparency. When the light shines on the work, the glass seems to glow. Internal reflections seem to multiply the light and the entire form glows with warmth. To me it suggests the sacredness of home, the spiritual experience of finding one's place, and belonging. Home is often used as a metaphor for the individual. Homes become expressions of our identity. The sculpture thus has a dual meaning expressing the sacred as a part of being.



I imagine this work transforming the experience of sacred space (see illustration), overlaying the temporal cycles of time and home onto the time of the sacred. Like a clock, the sculpture would glow to mark 9am and 5pm, the daily rhythm of home life. Light scoops in the ceiling would cut through the edges of the church, bringing the narrative of everyday cycles into the experience of the sacred. These cycles in turn are given added depth through the sculpture which reveals the sacrality of this ritual. The setting suggests that home is not just a place, but a spiritual experience of belonging. And this sense of belonging, this individuality and private expression of identity reveals the sacred. I must be in the church at the appropriate time in order to witness the time of the threshold.

- 12 This thesis underlies *American Sanctuary*, Nelson's collection of essays on sacred space which analyzes the sacred in unexplored places.

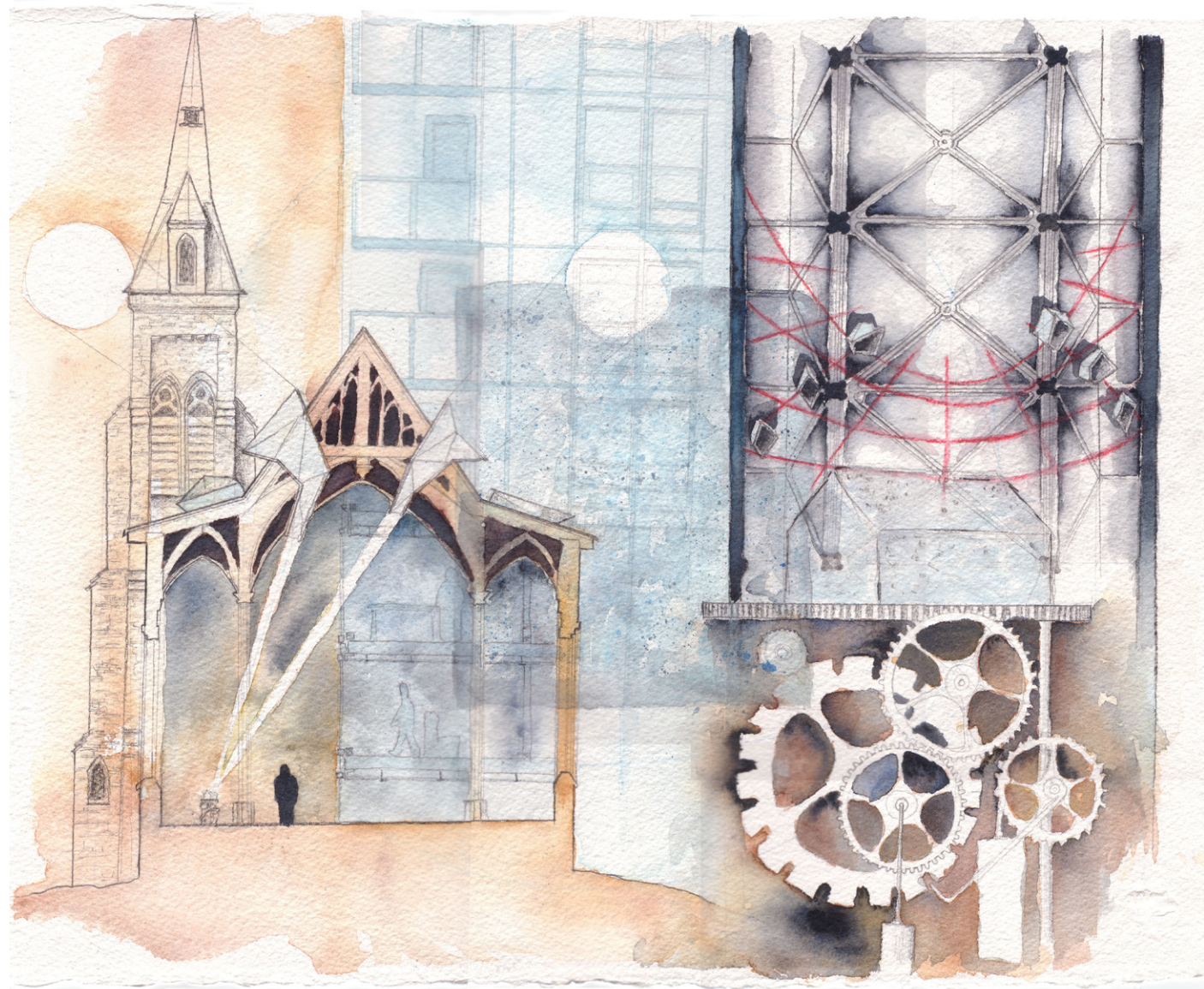

Bibliography

SACRED SPACE

- Bieler, Andre. *Architecture in Worship: the Christian place of worship - a sketch of the relationships between the theology of worship and the architectural conception of Christian churches from the beginnings to our day*. Edinburgh : Oliver & Boyd, 1965.
- Eliade, Mircea. *Sacred and the Profane: the nature of religion*. Translated by Willard R. Trask. New York: Harper & Row, 1961.
- Gorringe, T.J. *A Theology of the Built Environment: Justice, Empowerment, Redemption*. Cambridge: Cambridge University Press, 2002.
- Jones, Lindsay. *The Hermeneutics of Sacred Architecture: experience, interpretation, comparison*. Cambridge, MA: Harvard University Press, 2000.
- Kieckhefer, Richard. *Theology In Stone: church architecture from Byzantium to Berkeley*. Oxford: Oxford University Press, 2004.
- Nelson, Louis, ed. *American Sanctuary: understanding sacred spaces*. Bloomington: Indiana University Press, 2006.
- Otto, Rudolph. *Idea of the Holy; an inquiry into the non-rational factor in the idea of the divine and its relation to the rational*. Translated by John W. Harvey. London : Oxford University Press, 1958.
- Panofsky, Erwin. *Gothic Architecture and Scholasticism*. New York: Meridian Books, 1957.
- Schwarz, Rudolf. *Church Incarnate: the sacred function of Christian architecture*. Translated by Cynthia Harris. Chicago: Henry Regnery Company, 1958.
- Turner, Harold W. *From Temple to Meeting House: the phenomenology and theology of places of worship*. New York: Mouton Publishers, 1979.

QUOTIDIAN SPACE

- Di Cicco, Pier Giorgio. *Municipal Mind: manifestos for the creative city*. Toronto: Mansfield Press, 2007.
- Taylor, Charles. *A Secular Age*. Cambridge, MA.: Belknap Press of Harvard University Press, 2007.
- Vesely, Dalibor. *Architecture in the Age of Divided Representation: the question of creativity in the shadow of production*. Cambridge, MA: MIT Press, 2004.
- Walter, Benjamin. *The Arcades Project*. Translated by Howard Eiland and Kevin McLaughlin. Cambridge, MA: Belknap Press, 1999.

BIBLICAL EXEGESIS

- Achtemeier, Paul J., ed. *The HarperCollins Bible Dictionary*. Edited with the Society of Biblical Literature. San Francisco: HarperSanFrancisco, 1996.
- Brown, Raymond E., Joseph A. Fitzmyer and Ronald E. Murphy, eds. *The New Jerome Biblical Commentary*. New Jersey: Prentice-Hall, 1990.
- Mays, James L., ed. *The HarperCollins Bible Commentary*. Edited with the Society of Biblical Literature. San Francisco: HarperSanFrancisco, 2000.

OTHER

- Heidegger, Martin. "Building Dwelling Thinking." In *Basic Writings from Being and Time To The Task of Thinking*. Edited by David Farrell Krell. New York: Harper & Row, 1977.
- Ricoeur, Paul. "Architecture and Narrative." Paper presented at the 19th Triennale di Milano Conference, Identity and difference: integration and plurality in today's forms. Milano: Electa, 1996.

Appendix A: Recent Landmark Roman Catholic Church Projects



Chapel of St. Mary of the Angels
Mecanoo Architecten
Rotterdam, The Netherlands, 2000



Jubilee Church
Richard Meier & Partners
Rome, Italy, (2003)



Chapel of St. Ignatius
Steven Holl Architects
Seattle Washington,
(1997)



Church of San Giovanni Rotondo
Renzo Piano Building Workshop
Foggia, Italy, 2004



Novy Dvur Monastery
John Pawson
Pilsen Czech Republic
(2004)



Holy Rosary Complex
Trahan Architects
Baton Rouge,
Louisiana (2004)



Church of the Sacred Heart
Allman, Sattler, Wappner
Munich Germany, 2000



Cathedral of Our Lady of the Angels
Jose Rafael Moneo
Los Angeles, California, (2002)



Saint Gabriels
Larkin Architects
Toronto, Canada (2006)