

Modeling the Impact of Automated Materials  
Locating & Tracking Technology on the  
Construction Supply Network

by

Duncan A. Young

A thesis  
presented to the University of Waterloo  
in fulfillment of the  
thesis requirement for the degree of  
Master of Applied Science  
in  
Civil Engineering

Waterloo, Ontario, Canada, 2009

© Duncan A. Young 2009

## **AUTHOR'S DECLARATION**

I hereby declare that I am the sole author of this thesis. This is a true copy of the thesis, including any required final revisions, as accepted by my examiners.

I understand that my thesis may be made electronically available to the public.

## **Abstract**

Ineffective materials and equipment management continues to be a leading cause of poor performance on construction projects today. Many of the problems arise as a result of the inability to convey information pertaining to the location and status of construction material and equipment in an accurate and efficient manner. The integration of automated materials locating and tracking technologies (AMLTT) within the construction supply network presents a viable solution to this problem. The objective of this thesis is to further the understanding of the broader impact which these technologies could have on construction supply network management and the construction management process in general. This knowledge, however limited, is increasingly important as leaders in other industry sectors are beginning to report tangible benefits as a result of the integration of these technologies within their organizations' supply networks. Using a modeling and simulation approach, the impact of AMLTT on three segments of the construction supply network, typical to most large scale and industrial construction projects, was investigated. The results indicate the potential for AMLTT to have a positive impact on resource allocation, productivity, risk mitigation, and improving the overall performance of the construction supply network in general.

## **Acknowledgements**

First, I would like to express my sincere thanks to Dr. Carl T. Haas for his guidance and encouragement during the development of this manuscript. I feel privileged to have had Dr. Haas as both a research supervisor and mentor.

I would also like to thank NSERC, the Construction Industry Institute, Ontario Power Generation, Identec Solutions, and SNC-Lavalin for their support of this research effort. In particular, I would like to thank Mr. Paul Murray, P.Eng. of SNC-Lavalin for his support of the Portlands Energy Center (PEC) field trial. The experiences gained at PEC proved to be instrumental in developing the basis for this thesis.

Furthermore, I would like to acknowledge the faculty and staff of the Civil & Environmental Engineering Department at the University of Waterloo for all of their efforts during my tenure as an undergraduate and graduate student. In addition, my fellow graduate students Saiedeh Razavi, Hassan Nasir, Di Zhang, Yelda Turkan, and others have all been exceptional people to work alongside.

I owe many thanks to my family and friends: to my parents, thank you for always being there to offer assistance and provide support; to Alicia, thank you for always reminding me about life outside of engineering; to my grandfather, thank you for teaching me to work with my hands; and Darryl, thank you for being an exceptional friend since our first day of university.

Finally, Kate, thank you for being the cornerstone in my life.

# Table of Contents

List of Figures .....	ix
List of Tables .....	xi
Chapter 1 Introduction.....	1
1.1 General .....	1
1.2 Identified Research Need .....	3
1.3 Overall Research Objective & Scope .....	4
1.3.1 Secondary Research Objectives.....	4
1.4 Research Methodology .....	5
1.5 Structure of Thesis.....	6
Chapter 2 Background & Literature Review .....	8
2.1 General .....	8
2.2 Supply Chain Management .....	8
2.2.1 Lean Production.....	8
2.2.2 Evolution of Supply Chain Management .....	10
2.2.3 Supply Chain Management & the Construction Industry.....	11
2.3 Automated Materials Locating & Tracking Technology (AMLTT) .....	18
2.3.1 Radio Frequency Identification (RFID) .....	18
2.3.1.1 Key Components of an RFID System .....	19
2.3.1.1.1 RFID Transponder.....	19
2.3.1.1.2 RFID Reader.....	21
2.3.1.1.3 Data Processing System .....	22
2.3.1.2 RFID vs. the Barcode .....	22
2.3.1.3 RFID Technology Adoption.....	24
2.3.2 Global Positioning System (GPS) .....	24
2.3.2.1 NAVSTAR GPS.....	25
2.3.2.1.1 Space Segment.....	25
2.3.2.1.2 Control Segment.....	26
2.3.2.1.3 User Segment.....	26
2.3.2.2 GPS Applications .....	27
2.3.3 AMLTT & the Construction Industry .....	28
2.4 Simulation .....	34

2.4.1 Simulation & Its Advantages.....	34
2.4.2 Simulation & the Construction Industry.....	36
2.4.2.1 Analysis of Construction Supply Networks Using Simulation .....	37
Chapter 3 Formulated Simulation Models .....	39
3.1 General .....	39
3.2 Field Trials .....	40
3.2.1 Rockdale Field Trial.....	41
3.2.2 Portlands Field Trial.....	42
3.3 EZStrobe: General-Purpose Simulation System.....	45
3.4 On-site Material Receiving Process .....	48
3.4.1 Existing Material Receiving Process Model .....	49
3.4.1.1 Rate of Arrival of Loads to the Site.....	49
3.4.1.2 Offloading Material .....	50
3.4.1.3 Material Receiving Process .....	51
3.4.1.4 Inputting Data into Materials Management System .....	52
3.4.2 Modified Material Receiving Process 1: Fixed RFID Readers .....	54
3.4.2.1 Modifications Incorporated into EZStrobe Model .....	56
3.4.3 Modified Material Receiving Process 2: Mobile RFID Readers.....	59
3.4.3.1 Modifications Incorporated into EZStrobe Model .....	61
3.4.4 Modified Material Receiving Process 3: Crew Based Mobile RFID Readers .....	63
3.4.4.1 Modifications Incorporated into EZStrobe Model .....	63
3.4.5 Modified Material Receiving Process 4: Untagged Material .....	66
3.4.5.1 Modifications Incorporated into EZStrobe Model .....	67
3.5 Locating Material in a Construction Laydown Yard.....	69
3.5.1 Existing Process Model .....	69
3.5.1.1 Requests for Material Release .....	71
3.5.1.2 Approval of Material Requests.....	72
3.5.1.3 Retrieval of Requested Material .....	72
3.5.1.4 Search Process .....	73
3.5.2 Modified Material Locating Process .....	74
3.5.2.1 Modifications Incorporated into EZStrobe Model .....	75
3.6 Increasing Visibility within the Construction Supply Network .....	80
3.6.1 Existing Supply Chain Model .....	82

3.6.1.1 Part 1 – Fabrication .....	83
3.6.1.1.1 Generate Specifications .....	83
3.6.1.1.2 Design Elements .....	84
3.6.1.1.3 Fabrication .....	85
3.6.1.1.4 Transport .....	86
3.6.1.2 Part 2 – Installation .....	87
3.6.1.2.1 Receive Material .....	87
3.6.1.2.2 Install Area Preparation .....	88
3.6.1.2.3 Pre-Installation Work .....	89
3.6.1.2.4 Installation .....	89
3.6.2 Modified Supply Chain Model .....	93
3.6.2.1 Part 1 – Fabrication .....	94
3.6.2.2 Part 2 – Installation .....	96
3.6.2.3 Part 3 – Work Opportunity Generation .....	96
Chapter 4 Simulation Results .....	105
4.1 General .....	105
4.2 On-site Material Receiving Process .....	105
4.2.1 Total Processing Time per Load .....	106
4.2.2 Operation Duration .....	109
4.2.3 Labour Resource Allocation .....	111
4.2.3.1 Work Crew Allocation .....	112
4.2.3.2 Clerk Allocation .....	114
4.2.4 Average Receiving Time & Overall Efficiency Rating .....	116
4.3 Locating Material in a Construction Laydown Yard .....	119
4.3.1 Summary of Existing Process Model Output .....	120
4.3.2 Summary of Modified Process Model Output .....	122
4.3.3 Risk Associated with Lost Material .....	123
4.4 Increasing Visibility within the Construction Supply Network .....	127
4.4.1 Summary of Existing Supply Chain Model Output .....	128
4.4.2 Summary of Modified Supply Chain Model Output .....	131
4.4.3 Comparison of Schedule Performance .....	133
4.4.3.1 Comparing the Rate of Install Area Preparation .....	133
4.4.3.2 Comparing the Rate of Pre-Install Pipe Work .....	135

4.4.3.3 Comparing the Rate of Installation.....	136
4.4.3.4 Discussion.....	137
Chapter 5 Conclusions & Recommendations.....	138
5.1 General .....	138
5.2 Conclusions .....	139
5.2.1 On-Site Material Receiving Process.....	139
5.2.2 Locating Material in a Construction Laydown Yard.....	141
5.2.3 Increasing Visibility within the Construction Supply Network .....	141
5.2.4 Overall Conclusions .....	142
5.3 Recommendations for Future Work .....	143
Appendices .....	146
Appendix A .....	146
Appendix B.....	154
Bibliography.....	161



## List of Figures

Figure 2.1 – Manufacturing as a Conversion Process (adapted from Koskela, 1992) .....	9
Figure 2.2 – Manufacturing as a Series of Conversions (adapted from Koskela, 1992) .....	9
Figure 2.3 – Overall Construction Supply Network (adapted from Cox et al, 2007).....	12
Figure 2.4 – Examples of Passive & Active RFID Transponders (NTS).....	20
Figure 2.5 – Handheld RFID Reader.....	22
Figure 3.1 – Sandow Steam Electric Station (June 2007) (Photo Credits: S. N. Razavi) .....	41
Figure 3.2 – Portlands Energy Center (November 2007).....	43
Figure 3.3 – Portlands Energy Center (June 2008) .....	43
Figure 3.4 – Simplified Existing Material Receiving Process.....	49
Figure 3.5 – Existing Material Receiving Process .....	53
Figure 3.6 – Truck passing through laydown yard gate with fixed RFID readers .....	55
Figure 3.7 – Simplified Modified Material Receiving Process 1: Fixed RFID Readers.....	56
Figure 3.8 – Modified Material Receiving Process 1: Fixed Readers .....	58
Figure 3.9 – Worker using a mobile RFID reader in a construction laydown yard.....	60
Figure 3.10 – Simplified Modified Material Receiving Process 2: Mobile Readers.....	60
Figure 3.11 – Modified Material Receiving Process 2: Mobile Readers .....	62
Figure 3.12 – Simplified Modified Material Receiving Process 3: Crew Based Mobile Readers .....	63
Figure 3.13 – Modified Material Receiving Process 3: Crew Based Mobile Readers .....	65
Figure 3.14 – Simplified Modified Material Receiving Process 4: Untagged Material.....	66
Figure 3.15 – Modified Material Receiving Process 4: Untagged Material.....	68
Figure 3.16 – Simplified Existing Material Locating Process.....	70
Figure 3.17 – Incorporating Possible Search for Lost Material in Existing Process.....	70
Figure 3.18 – Existing Material Locating Process Model.....	78
Figure 3.19 – Modified Material Locating Process Model .....	79
Figure 3.20 – Simplified Existing Pipe Spool Supply Chain Model Part 1 (Fabrication).....	84
Figure 3.21 – Simplified Existing Pipe Spool Supply Chain Model Part 2 (Installation).....	87
Figure 3.22 – Existing Pipe Spool Supply Chain Model Part 1 (Fabrication) .....	91
Figure 3.23 – Existing Pipe Spool Supply Chain Model Part 2 (Installation).....	92
Figure 3.24 – Increasing Work Opportunities via Improved Supply Chain Visibility.....	93
Figure 3.25 – Structure of Data Filter Mechanism in Part 3 .....	98
Figure 3.26 – Modified Pipe Spool Supply Chain Model Part 1 (Fabrication).....	100

Figure 3.27 – Modified Pipe Spool Supply Chain Model Part 2 (Installation) .....	101
Figure 3.28 – Modified Pipe Spool Supply Chain Model Part 3 - Subroutine 1 (Pre-Install).....	102
Figure 3.29 – Modified Pipe Spool Supply Chain Model Part 3 – Subroutine 2 (Install Area Preparation) .....	103
Figure 3.30 – Modified Pipe Spool Supply Chain Model Part 3 - Subroutine 3 (Pipe Spool Installation).....	104
Figure 4.1 – Total Processing Time per Load .....	107
Figure 4.2 – Operation Duration .....	110
Figure 4.3 – Work Crew Allocation .....	112
Figure 4.4 – Clerk Allocation.....	115
Figure 4.5 – Receiving Time per Load.....	117
Figure 4.6 – Overall Process Efficiency Rating .....	118
Figure 4.7 – Percentage of Items Located Immediately .....	121
Figure 4.8 – Breakdown of Items Requiring Multiple Search Attempts.....	121
Figure 4.9 – Percentage of Items Located Immediately .....	122
Figure 4.10 – Breakdown of Items Requiring Multiple Search Attempts.....	123
Figure 4.11 – Population vs. Time – 60% Install Buffer.....	129
Figure 4.12 – Percent Complete vs. Time - 60% Install Buffer .....	129
Figure 4.13 – Population vs. Time - Work Opportunities .....	132
Figure 4.14 – Percent Complete vs. Time - Work Opportunities.....	132
Figure 4.15 – Comparing the Rate of Install Area Preparation .....	134
Figure 4.16 – Comparing the Rate of Pre-Install Pipe Work .....	135
Figure 4.17 – Comparing the Rate of Installation .....	136

## List of Tables

Table 3.1 – EZStrobe Modeling Elements .....	47
Table 4.1 – Risk Assessment of Existing Process Arrangement.....	124
Table 4.2 – Risk Assessment of Modified Process Arrangement .....	125

# Chapter 1

## Introduction

### 1.1 General

The construction industry is dominated by a large number of ‘one-off’ projects that draw upon multi-skilled teams of professionals to complete a variety of complex tasks in a relatively short period of time. No two projects are constructed under exactly the same conditions, with the same methods and tools, or with the same set of materials (Cox, Ireland, & Townsend, 2006; Tah, 2005; Briscoe & Dainty, 2005; Vrijhoef & Koskela, 2000). This is especially the case with large scale construction projects such as oil refineries, power generation facilities, and skyscrapers, which are distinguished by their overall unique nature and complexity. Likewise, the supply networks that fuel these projects with labour, equipment, and highly engineered materials are complex entities onto themselves. Unlike their manufacturing counterparts, which input a constant level of labour and material into a specified process over a relatively long period of time, a construction supply network is characterized by the complex attributes of the project that it is associated with. A construction supply network not only brings together the required project resources, but it must also be robust enough to contend with frequent changes in project requirements (i.e. design & schedule), a highly competitive and adversarial market environment, and a multitude of contractual arrangements (Cox, Ireland, & Townsend, 2006). Consequently, the effective management of the supply network is a contributing factor to achieving overall project success.

Construction supply network management has its origins with the adoption of ‘Lean’ techniques in the manufacturing industry, which originated with the Toyota Production System. Supply network management, in general, is focused on coordinating all of the

components found at all levels of the supply network, from the initial supplier of raw material to the end product user (Harland, 1996; Vrijhoef & Koskela, 2000). However, the fundamental differences that exist between the construction and manufacturing processes have made it difficult to directly apply manufacturing supply chain management practices, such as Just-In-Time delivery, to the construction industry. Nevertheless, with increasing client imposed pressure on construction management teams to reduce schedule durations and decrease costs, while continuing to produce a high quality finished product, the value and importance of improving the management of construction supply networks remains (Vrijhoef & Koskela, 2000).

Improving the materials management process, particularly at the site level on large construction projects, has been identified as one area which can have a beneficial impact on the construction supply network and the construction process as a whole (Silver, 1988; Construction Industry Institute, 1999; Kini, 1999). Construction materials management can be defined simply as the process by which the correct material is made available on site at the required time (Construction Industry Institute, 1999). The need for improvement is a result of poor materials management being one of the leading causes of disruptions on construction projects (Construction Industry Institute, 1999; Plemmons & Bell, 1995; Thomas, Riley, & Messner, 2005). The most common problems that arise with regards to materials management on construction projects include: lack of required materials, poor storage of critical equipment, improperly sequenced delivery of material, and overall process inefficiencies (Thomas, Riley, & Messner, 2005). The encountered problems are in part a result of materials management, particularly at the site level, continuing to be a human based activity assisted only in part by various information technologies (e.g. inventory databases, handwritten log books, etc.). The integration of Automated Materials Locating and Tracking Technologies (AMLTT), namely Radio Frequency Identification (RFID) and the Global

Positioning System (GPS), and the automation of part of the materials management process have been proposed and shown to be a viable means of process improvement (Jaselskis, Anderson, Jahren, Rodriguez, & Njos, 1995; Jaselskis & El-Misalami, 2003; Song, Haas, & Caldas, 2006; Song, Haas, Caldas, Ergen, & Akinci, 2006; Ergen, Akinci, & Sacks, 2007; Razavi, et al., 2008)

## **1.2 Identified Research Need**

A significant research effort has been put forth over the last decade into investigating the feasibility of applying AMLTT in the construction industry. The initial research efforts have focused on demonstrating the ability of AMLTT to withstand the operating conditions typically found on construction projects (e.g. exposure to the elements, signal reception, etc) and determining suitable applications. The technologies have thus far been shown to be well suited for application in the construction industry, especially with regards to accurately identifying, locating, and tracking material and equipment in a construction environment (Jaselskis & El-Misalami, 2003; Song, Haas, & Caldas, 2006; Song, Haas, Caldas, Ergen, & Akinci, 2006; Ergen, Akinci, & Sacks, 2007; Torrent & Caldas, 2007; Razavi, et al., 2008). However, what is currently lacking from the body of knowledge, on the application of AMLTT in construction, is an understanding of the impact that this technology could have on a project on a larger scale. Specifically, what impact(s) could AMLTT have if it were implemented within the construction supply network? This knowledge, however limited, is increasingly important as leaders in other industries are beginning to report tangible benefits as a result of the integration of AMLTT within their organizations supply chains (Hedgepeth, 2007; Lehpamer, 2008).

### **1.3 Overall Research Objective & Scope**

The overall objective of this thesis is to investigate the theoretical impact that the application of AMLTT could have on the construction materials management process if implemented within different segments of the supply network. Three specific areas of the construction supply network were chosen for investigation of the application of AMLTT: 1) the on-site materials receiving process, 2) the task of locating material in a construction laydown yard and 3) the use of AMLTT to increase the level of visibility within the greater supply network. These segments of the supply network were chosen based on the positive results of past field trials (applications 1 & 2) and the completion of a detailed literature review that identified a use of AMLTT not fully investigated in the construction industry (application 3). To examine the impact of AMLTT at the project level, each of these segments of the construction supply network were modeled using a commercially available modeling and simulation software package. To provide a frame of reference the industrial piping sector was chosen as the basis for the construction supply network models. Such a frame of reference allows for the models to be calibrated and validated using actual field data. Furthermore, industrial piping, which for the purposes of this thesis includes pipe spools, valves, pipe supports and hangers, and other related components, has been identified as an area of industrial construction that could benefit from the application of AMLTT (Jaselskis & El-Misalami, 2003).

#### **1.3.1 Secondary Research Objectives**

The following sub-objectives were developed to serve as a guide for completing the stated primary research objective:

- Develop a series of models that simulate the typical characteristics of different segments of the construction supply network.

- Incorporate Automated Materials Locating and Tracking technologies (i.e. RFID & GPS) within the developed construction supply network models.
- Investigate the impacts, such as more effective resource allocation and improved productivity, which the implementation of AMLTT may have on the performance of the simulated supply network.

Successful completion of these objectives should result in an understanding and useful models of the mechanics of how AMLTT impacts the construction supply network and ultimately construction project performance.

#### **1.4 Research Methodology**

A research methodology to complete the listed research objectives is outlined below:

- Complete a detailed review of the existing literature on all of the related research subject areas such as: supply chain management (manufacturing & construction), RFID & GPS and their role in the construction industry, and the application of simulation in the construction industry.
- Outline the various functional elements required to accurately model the chosen segments of the construction supply network.
- Collect the required data to accurately simulate each model element.
- Develop the base models for the chosen segments of the construction supply network.
- Determine the most feasible means in which AMLTT could be integrated into the developed supply network models.
- Assess the robustness of the developed supply network models. This includes consultation with members of the construction industry and validation with field data where possible.



- Evaluate and report the impact that the integration of AMLTT within the developed supply network models had on efficiency of resource allocation, productivity, risk mitigation, and schedule performance.
- Comment on the generality of the models used and their potential as tools for analyzing future changes.
- Provided conclusions and recommendations for further research.

### **1.5 Structure of Thesis**

This thesis has been broken down into five principal chapters. Chapter 1 outlines the need for further investigation into the impact of AMLTT on the construction supply network. In addition, the overall research objective and scope, as well as sub-objectives and guiding research methodology are outlined within this chapter.

Chapter 2 presents a synopsis and discussion of the subject areas pertinent to this thesis. First, attention is given to the history and development of supply chain management and its application to the construction industry. Next, an understanding of the fundamental technological components of AMLTT is established. This is followed by a review of the research efforts focused on utilizing AMLTT within the construction industry. Finally, this chapter concludes with a discussion of the use of modeling and simulation as a means of analyzing construction processes.

Chapter 3 describes the formulated simulation models for each segment of the construction supply network under investigation. A brief discussion is included with regards to describing the syntax and logic associated with the modeling and simulation platform employed. In addition, this chapter describes two field trials which served as the basis for the developed models and for this thesis in general.

Chapter 4 reports the results for each series of models outlined in Chapter 3. The manner in which each set of results is presented varies as each set of models is characteristically different. In some cases, only the key results for a particular set of models are presented within the text of the thesis. In such a case, the reader will be directed to the appropriate appendix for the remaining results.

Finally, Chapter 5 outlines the key conclusions drawn from the completed investigation and provides a list of recommendations for future work. Conclusions are presented both in terms of each specific area of the construction supply network examined and in terms of the broader impact of AMLTT on construction supply network management.

## **Chapter 2**

### **Background & Literature Review**

#### **2.1 General**

The overall purpose of this chapter is to discuss the pertinent details of the subject areas of relevance to this thesis. First, the theories behind supply chain management and its adoption by the Western manufacturing sector in the last third of the 20<sup>th</sup> century is discussed. This is followed by a summary of the arguments that have been made for and against the adoption of these practices in the construction industry. Next, the important aspects of Automated Materials Locating and Tracking Technology and its application in the construction industry to date are discussed. Finally, an overview of simulation and how it is used to analyze construction processes and construction supply networks is presented.

#### **2.2 Supply Chain Management**

##### **2.2.1 Lean Production**

The concept of supply chain management is a product of Lean Production, which itself has evolved from the Toyota Production System (TPS) (Koskela, 1992; Lamming, 1996; Construction Industry Institute, 2005). The TPS was developed in post-war Japan in the 1950's and 1960's and has since been made famous by the success of the Just-In-Time delivery system (JIT). JIT allowed Toyota to operate with near zero inventories in a time when Japan was suffering from a lack of a surplus of raw materials and storage space (Koskela, 1992; Construction Industry Institute, 2005). The overall purpose of the TPS was to increase the quality of the manufactured product, while also increasing efficiency of the manufacturing process, which facilitated the ability of the Japanese automaker to compete with its North American and European counterparts (Koskela, 1992).

The concept of Lean Production has evolved from the principles behind the TPS. The focus of Lean Production is on the reduction of non-value adding activities commonly found in the manufacturing process. The traditional manufacturing process, described in Figure 2.1, can be described as a conversion process: a series of inputs (i.e. material & labour) are converted by a defined process into a final output (i.e. finished product) (Koskela, 1992; Diekmann, Krewedl, Balonick, Stewart, & Won, 2004).

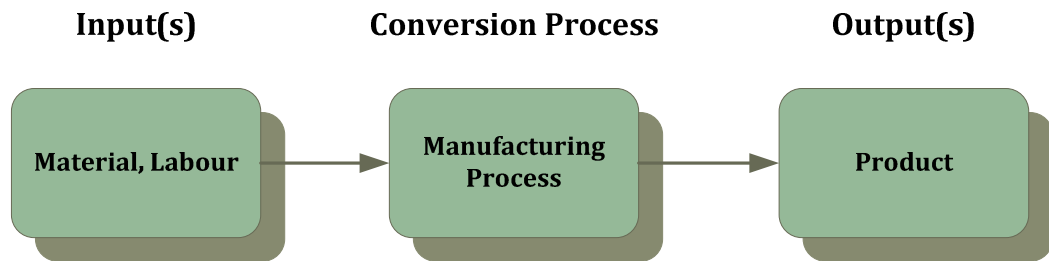

**Figure 2.1 – Manufacturing as a Conversion Process (adapted from Koskela, 1992)**

In the past, when the scale of production was limited, the view of the manufacturing process as a single conversion was valid (i.e. cottage industries). However, technological developments over the past century have increased the complexity of the manufacturing process, resulting in not a single conversion process, but a series of connected conversion processes, as depicted in Figure 2.2.

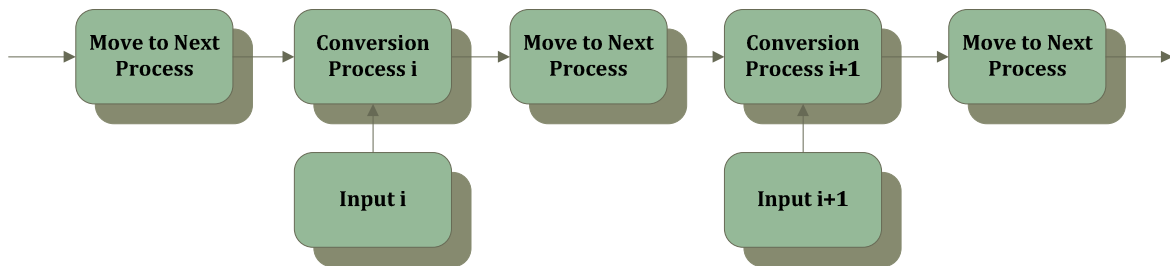

**Figure 2.2 – Manufacturing as a Series of Conversions (adapted from Koskela, 1992)**

Lean Production, however, shifts away from viewing the manufacturing process as a series of conversions and instead regards it in terms of the flow of information and material (Koskela, 1992; Diekmann, Krewedl, Balonick, Stewart, & Won, 2004). The flow model of manufacturing continues to recognize the existing conversion processes, but it also places an emphasis on identifying the flow processes, which are neglected in the conversion model. Flow processes are those processes which connect the various conversions together (Koskela, 1992). Typical flow processes include the transportation of material between work areas, maintaining an inventory of required components, and the inspection of completed work at each stage of the overall process. Furthermore, the flow model differentiates between value adding and non-value adding activities. A process which adds value to the product for the end consumer (i.e. improved features) is considered to be value adding. Flow processes are predominately classified as non-value adding activities and conversion processes as value adding. Non-value adding activities in a typical manufacturing process range from 3 to 20% of the overall process (Koskela, 1992). The goal of Lean Production is to reduce or eliminate non-value adding activities (i.e. flow processes) and improve the efficiency of value adding activities (i.e. conversion processes) (Koskela, 1992; Diekmann, Krewedl, Balonick, Stewart, & Won, 2004). The concept of supply chain management evolved from this production philosophy and is evident in JIT.

### **2.2.2 Evolution of Supply Chain Management**

Supply Chain Management (SCM) evolved as a concept in the late 1970's as the North American and European manufacturing sectors began to realize the beneficial impacts of JIT. The principle behind JIT is to deliver the right amount of material required to complete a series of specific production tasks at just the right point in time, facilitating the holding of zero inventories (Harland, 1996; Vrijhoef & Koskela, 2000). JIT requires a near perfect standard of quality control and the elimination of variability in the delivery of components

from suppliers, anything less would result in the halt of production. To achieve this required level of efficiency an organization has to have an understanding of and a high level of control over their entire supply chain, both in the upstream and downstream direction (i.e. their suppliers and those they supply to). These organizational requirements lead to the development of SCM (Lamming, 1996). SCM focuses on coordinating the efforts of all parties within the supply network, so as to increase the efficiency of the network as a whole (Harland, 1996; Vrijhoef & Koskela, 2000). It does so by concentrating on the relationships between an organization and its suppliers, the supply networks and chains within the organization itself, and the performance of those networks and chains, both external and internal (Harland, 1996). In other words, SCM seeks to add value across the entire supply network by reducing or eliminating non-value adding components (e.g. defective parts, cost of carrying inventories of components, etc). The success of SCM in the manufacturing sector has led to interest in its application in other industries, including the construction industry.

### **2.2.3 Supply Chain Management & the Construction Industry**

The predominant theories behind SCM in the construction industry are the same as those in the manufacturing industry. Figure 2.3 describes the organization of a typical construction supply network. However, in this case the encompassing philosophy is termed ‘Lean Construction’. The focus of Lean Construction is on the development of an efficient project delivery system by eliminating or reducing the prevalence of non-value adding activities from the construction process (Koskela, 1992; Howell & Ballard, 1999; Diekmann, Krewedl, Balonick, Stewart, & Won, 2004; Salem, Salomon, Genaidy, & Minkarah, 2006). Non-value adding activities in construction include idle work crews, multiple handling of material, rework, and accidents (Koskela, 1992). This is essentially the same guiding principle behind Lean Production. The originators of the Lean Construction philosophy argue that the

construction process can be viewed in a similar manner as manufacturing; simply as a series of conversion processes connected by flow processes. And like manufacturing, construction has suffered from a lack of acknowledgement of the existence of these flow processes (Koskela, 1992). The examination of a typical construction schedule lends weight to this argument. For example, if a flow process, such as searching for the required material in a laydown yard, is not included within the schedule network, it will go unaccounted for, even though the occurrence of this activity has very real implications on the project in terms of cost and productivity.

Lean Construction divides construction into two overall processes, namely the material and work processes. The material process accounts for the overall supply of resources to the site, as well as the handling and assembly of material on site. The work process focuses on the tasks of the construction teams on site (Koskela, 1992). As would be expected, the attention of construction SCM practitioners is on the material process.

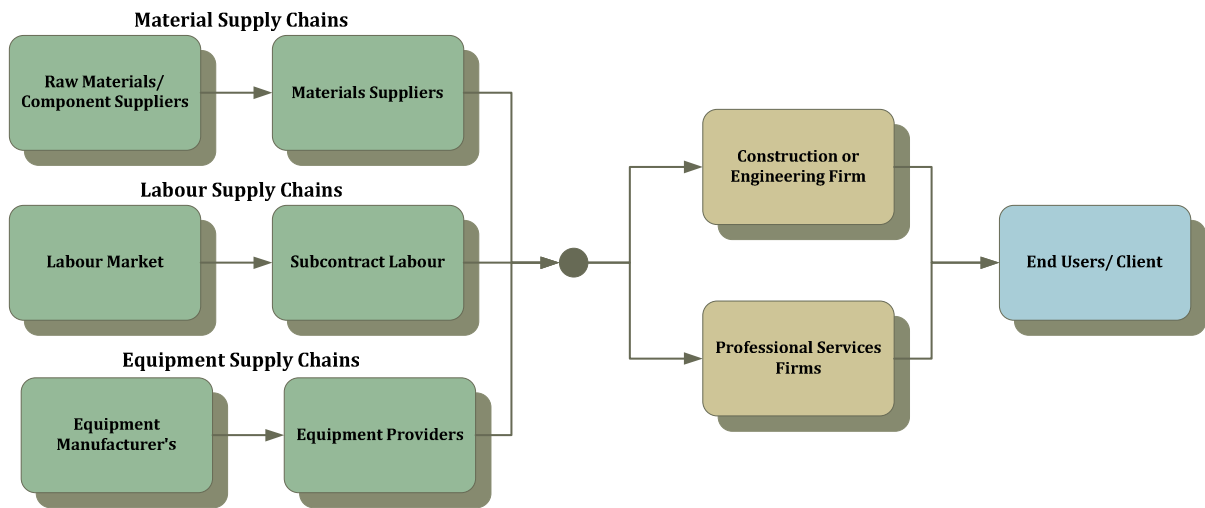

**Figure 2.3 – Overall Construction Supply Network (adapted from Cox et al, 2007)**

The application of SCM principles, such as JIT, has seen some success in the construction industry. O'Brien (1997) presented the results of a case study of a Norwegian condominium construction project that utilized a JIT material delivery system to reduce on-site material storage and handling. The responsibility for material storage, handling, and delivery to the site was downloaded to a firm that specialized in the supply of building materials. The general contractor provided the building material supplier with 'look-ahead' schedules to facilitate the organization of the JIT deliveries. The initial expectations for the project was that on-site productivity would increase due to less time spent on materials management and more time spent on installation. The general contractor was successful in increasing site production. However, variability in site production (due to weather, equipment breakdowns, etc) lead to increased costs for the primary building material supplier and affected the efficiency of the supply network as a whole (O'Brien, 1997).

Simulation was used by Tommelein (1998) and Al-Sudairi et al (1999) to demonstrate how Lean principles could impact supply network and project performance in construction. Tommelein (1998) focused on applying pull-driven scheduling to the pipe spool installation process. The pull-driven approach to scheduling and production focuses on ensuring the availability of resources (e.g. material, labour, & equipment) that allow for the completion of tasks in an order that facilitates the highest overall level of productivity. This approach differs from the more traditional push-driven production approach (e.g. CPM) that waits for all of the required resources to become available before beginning a task (Tommelein, 1998). Tommelein (1998) was successful in demonstrating the theoretical ability of pull-driven scheduling to improve the performance of the pipe spool installation process by reducing on-site material buffers, decreasing the project duration, and identifying a means in which to increase crew productivity by altering their start date. However, it was acknowledged that to successfully implement this technique in the field, it would require project stakeholders to



coordinate their efforts so as to achieve overall project success (Tommelein, 1998). The competitive nature of construction firms and variability in construction contracts makes this somewhat difficult. Al-Sudairi et al (1999) simulated a steel erection process with a focus on analyzing the impact that the elimination of material buffers could have on project performance. The results of the study indicated that a reduction in on-site material buffers (i.e. material stored on site) increased variability in site production due to the effect of uncertainties in material delivery. It was concluded that a moderate material buffer on site could balance the impact of uncertainty in material delivery and productivity (Al-Sudairi, Diekmann, Songer, & Brown, 1999). Both of the aforementioned research efforts were successful in simulating the application of Lean Construction principles; however, both studies acknowledged how common elements found within the construction industry hindered the ideal implementation of Lean principles, even at the simulation level.

Further research efforts have focused on identifying the role of SCM in construction (Vrijhoef & Koskela, 2000) and on assessing the level of SCM currently being applied in the construction industry (Vrijhoef & Koskela, 2000; Briscoe & Dainty, 2005). Vrijhoef & Koskela (2000) identified four roles of SCM in construction:

- 1) To reduce the cost and duration of site activities by ensuring a stable flow of resources to the site;
- 2) To reduce costs associated with transportation, and storage of material on and off site;
- 3) To move activities performed on site to other stages within the supply chain, thus taking advantage of better working conditions (i.e. in a controlled environment);
- 4) And, to further integrate the management of the construction site and the supply chain.

Vrijhoef & Koskela (2000) went on to examine the supply chains of three construction projects (two residential projects and one office building). From this analysis it was

determined that there exist significant problems (from a Lean perspective) in a typical construction supply chain, such as the inclusion of extra time in schedules to counteract uncertainties and the overall nearsighted management of the supply chain in general. It was also recognized that more ‘practical’ methods of SCM, based on those four facets listed above, need to be developed to factor in the unique characteristics of construction projects. Briscoe & Dainty (2005) came to a similar conclusion in regards to the ability to achieve a fully integrated supply chain in today’s construction industry and that it may require a significant investment in terms of time and resources to see the same results as in the manufacturing industry.

The difficulty in applying SCM to construction in all of the studies mentioned above can be recognized to originate from the fundamental differences between manufacturing and construction. The construction industry is dominated by ‘one-off’ projects; where ‘one-off’ refers to the lack of repetition in the construction of like facilities (London, Kenley, & Agapiou, 1998; Vrijhoef & Koskela, 2000; Tah, 2005). Even those projects with great similarities are typically separated geographically by great distances and often by international borders, thus restricting the carryover of previous designs (Briscoe & Dainty, 2005; Wickramatillake, Lenny Koh, Gunasekaran, & Arunachalam, 2007). Construction schedules vary considerably between projects, some schedules span years, while others span only a few months (Briscoe & Dainty, 2005; Salem, Salomon, Genaidy, & Minkarah, 2006). Other constraints imposed on construction projects, such as weather, site conditions, site fabrication, availability of resources (e.g. skilled and unskilled labour), and local laws and regulations can also be highly unpredictable and variable (Koskela, 1992; Cox, Ireland, & Townsend, 2006). The end result of the combination of these inherent characteristics of construction are projects with highly complex and variable requirements, which in turn require supply networks of a similar nature. It is the inherent presence of variability in

construction that has made the application of Lean and thus SCM techniques to the construction industry difficult so far.

The inherent variable nature of construction is the principle reason why some researchers would argue that it is not possible to directly apply SCM techniques to the construction industry. Cox, Ireland, & Townsend (2006) argue that the ‘best practice’ for the majority of the construction industry is to not simply adopt or replicate the Lean and SCM practices adopted in other industries like manufacturing. They stress that the lean approach is applicable and makes sense in conditions where variety is low and production volume is high, but in construction a more ‘agile’ management approach is more appropriate. This would allow managers to adapt to the dynamic conditions imposed upon them by a particular project. They also suggest that few in the construction industry will be able to fully implement SCM practices as it requires a significant investment in resources that may not fully pay off by the time the project is completed. Furthermore, SCM requires the client or the client’s representative (i.e. general contractor) to have complete dominance over their suppliers, which in today’s business environment often requires purchasing power on a global scale (Cox, Ireland, & Townsend, 2006). Not all clients or their representatives partaking in the construction of a facility have this leveraging ability. Regardless of which argument over the applicability of SCM to construction one agrees with, there exists an identified need for the improvement of the construction materials management process, particularly at the site level.

Materials management at the site level, in general, is focused on ensuring that the right materials are available for work crews at the right point in time. However, the typical responsibilities of the materials management team on a construction project are actually quite broad and include: procurement and purchasing, expediting, logistics management, field control of materials, operating and maintaining a warehouse or laydown yard, and the

disposal of surplus material at the time of project completion (Construction Industry Institute, 1999; Kini, 1999). Over the past two decades the overall process of construction materials management, especially on large projects, has received significant attention (Construction Industry Institute, 1986; Silver, 1988; Plemmons & Bell, 1995; Construction Industry Institute, 1999; Kini, 1999; Thomas, Riley, & Messner, 2005). This attention has in part been garnered due to the magnitude of cost associated with construction materials on a typical project (Silver, 1988). It is not uncommon for 50-60% of the total project cost of an industrial facility to be associated with materials and equipment, whereas only 10-15% of the total project budget is associated with engineering and design (Kini, 1999; Construction Industry Institute, 1999). More importantly, materials management has received significant attention due to the impacts that can be felt project wide if poor management procedures are practiced (Construction Industry Institute, 1999; Plemmons & Bell, 1995; Thomas, Riley, & Messner, 2005). Common materials related issues that can arise include: lack of availability of required material, inaccurate warehouse records, damage of critical material or equipment due to improper storage, improperly sequenced deliveries, and large surpluses of material at project completion (Plemmons & Bell, 1995; Thomas, Riley, & Messner, 2005). The end results of the occurrence of these poor practices are delays in the project schedule and extra incurred costs. In today's business climate where construction management teams are being pressured by clients to reduce schedule durations and decrease costs, the impact that these errors can have on a project is greatly intensified.

One of the primary reasons why site materials management continues to suffer from the abovementioned problems is that it continues to rely heavily on information that is collected, recorded, and conveyed manually. On-site materials management is typically composed of a primary human component assisted only in part by different information technologies (e.g. computer based inventory databases, hand written log books, etc). A site warehouse worker

must receive material delivered to the site, store the material in a suitable location, and subsequently retrieve that material for use by a work crew at a later date. There is specific information associated at each step in this process that must be accurately recorded and made available to others within the project management structure. As with any human based process, an inherent level of error must be taken into account and in this case there is the possibility for error to occur at each step of the process. Errors may include mis-receiving a shipment of material (e.g. wrong quantity or material type recorded) or not storing a piece of equipment in the designated location, leading to the inability to locate it when required. When these errors go unchecked or unaccounted for, they can propagate into the serious project level problems previously mentioned. The introduction of new technologies, which fall under the category of Automated Materials Locating and Tracking Technology (AMLTT) and the automation of specific aspects of the site materials management process have been proposed and shown to be a viable means of improving this process as a whole.

### **2.3 Automated Materials Locating & Tracking Technology (AMLTT)**

This section will focus on a discussion of the primary technologies which facilitate AMLTT, which are Radio Frequency Identification (RFID) and the Global Positioning System (GPS). The discussion will include a brief history of the development of each technology and how it compares to other technologies currently in place (e.g. Barcodes). Following this will be a discussion of the past and present application of AMLTT in the Construction industry.

#### **2.3.1 Radio Frequency Identification (RFID)**

Radio Frequency Identification (RFID) is a segment of automated identification technology that utilizes radio waves to capture and transmit data regarding the state of different objects, persons, or beings (Jaselskis & El-Misalami, 2003). The technology's origins date back to early in the Second World War during the Battle of Britain and the development of radar.

The Royal Air Force's (RAF) *Identification, Friend or Foe* (IFF) system, which was used to identify RAF planes versus those of the German Luftwaffe, was the first successful application of the technology in early 1940 (Hedgepeth, 2007; Lehpamer, 2008). Development of RFID technology continued throughout the subsequent decades, but it was the rapid expansion of computing technology in the late 1980's and 1990's that allowed for it to become a more viable technological option (Hedgepeth, 2007; Lehpamer, 2008). Today applications of RFID can be seen in a variety of industry sectors including: agriculture (e.g. livestock identification), transportation (e.g. automatic highway toll collectors), and automotive (e.g. keyless entry).

### **2.3.1.1 Key Components of an RFID System**

An RFID system is composed of three key components. The first system component is the tag or transponder, which is affixed to the item of interest. The next system component is the RFID reader or interrogator, which usually includes an antenna. The final system component is some means of data filtering and processing (Shepard, 2005; Glover & Bhatt, 2006; Hedgepeth, 2007; Myerson, 2007; Lehpamer, 2008). Each of the three primary system components is discussed separately below.

#### **2.3.1.1.1 RFID Transponder**

On the simplest level an RFID transponder is composed of a memory chip and an antenna (Jaselskis & El-Misalami, 2003). Transponders are primarily classified as either passive or active, depending on how power is supplied. Passive RFID transponders have no dedicated power supply; instead they convert the Radio Frequencies (RF) emitted by the RFID reader into a DC current. The transponder remains passive or inactive until 'awoken' by a passing RFID reader. An example of a passive transponder is depicted in the left half of Figure 2.4. The lack of a dedicated power supply results in passive transponders having a relatively short

read range, usually less than 300 mm (Jaselskis & El-Misalami, 2003; Shepard, 2005; Hedgepeth, 2007). This read range corresponds to an operating frequency between 30 and 300 kHz (Shepard, 2005). The short read range of passive transponders is often offset by their relatively low cost, being approximately \$0.20 to \$0.30 per transponder (Hedgepeth, 2007). On the other hand, active transponders draw their power from an on board battery. An active transponder continually broadcasts its unique signal to be intercepted by an RFID reader that passes within its read range. An example of an active transponder is depicted in the right half of Figure 2.4. Depending on the model and operating environment, an active transponder can have a read range that varies from 1 to 100 m (Jaselskis & El-Misalami, 2003; Shepard, 2005; Hedgepeth, 2007). This corresponds to an operating frequency of 300 MHz to 3 GHz (Shepard, 2005). As expected, the purchase cost of active transponders is relatively high, being approximately \$20 to more than \$100 per transponder (Hedgepeth, 2007).

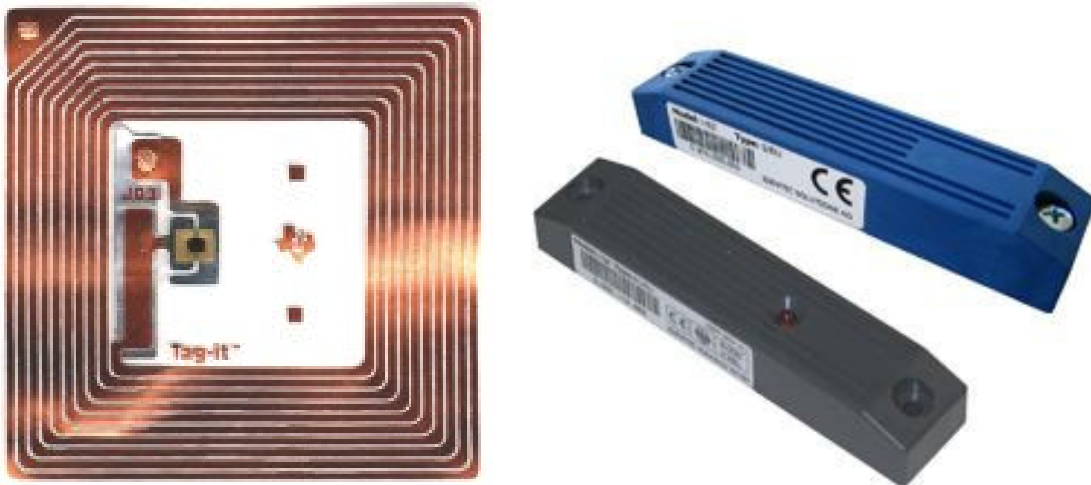

**Figure 2.4 – Examples of Passive & Active RFID Transponders (NTS)**

Besides being classified by power supply, RFID transponders are also classified according to their write capabilities. Read only transponders, usually of a passive nature, typically

contain enough memory to store a unique alphanumeric identification code. These transponders are usually programmed at the time of manufacture or at the time of first use (Jaselskis & El-Misalami, 2003). Read-Write transponders, usually of an active nature, can have memory capacities in the Megabyte range, allowing for increased data exchange capabilities throughout the lifetime of the item being monitored (Hedgepeth, 2007).

#### **2.3.1.1.2 RFID Reader**

The purpose of an RFID reader (a.k.a. RFID interrogator) is to recover the data being transmitted by the RFID transponders of interest. Like RFID transponders, there are a number of forms of RFID readers currently in use; they are classified as being either mobile or fixed. Mobile readers can be found in many forms of commercial devices, ranging from laptops or Personal Digital Assistants (PDA), which are integrated with a RFID scanner card and antenna. Figure 2.5 is an example of a mobile reader based on a PDA. Fixed RFID readers typically consist of a single or series of scanners attached to some sort of structure (e.g. warehouse door frame). The selection of reader type is directly related to the application in which RFID is being employed and the type of data sought. For example, a mobile RFID reader would be well suited for tracking the location of material on a construction site, whereas a fixed RFID reader would be well suited for monitoring the flow of goods into and out of a distribution warehouse.





**Figure 2.5 – Handheld RFID Reader**

### **2.3.1.1.3 Data Processing System**

The data processing system (DPS) typically performs a number of functions within the overall RFID system. The primary function of the DPS is to act as a database for all of the received RFID data sets. The DPS may also act as a filter, employing any number of predefined algorithms, to convert the received data into useable information. The DPS may also act as a link between the RFID transponder in the field and other business level applications already in operation (e.g. material purchasing software). Similar to the selection of an RFID reader, the level of complexity of the DPS is related to how RFID is being employed and the level of information being sought by the different system users.

### **2.3.1.2 RFID vs. the Barcode**

The barcode, developed more than 30 years ago for the grocery industry, is the principle automatic identification technology in use today (Hedgepeth, 2007; Lehpamer, 2008). A barcode, which is read by a laser scanner, is composed of a series of dark lines, of varying

widths, that correspond to alphanumeric characters. The series of characters form a 'key' that identifies the item in question in a product database (Lehpamer, 2008).

While barcodes are widely used, RFID has been identified as a more robust alternative. Hedgepeth (2007) and Glover & Bhatt (2006) have identified a series of advantages of RFID technology over barcode technology:

- **No Line of Sight Necessary:** A barcode must be visible for it to be scanned. An RFID transponder only requires the reader to enter within its read range to acquire its signal.
- **Longer Read Range:** A barcode must be read in relatively close range ( $\pm 250$  mm). An active RFID transponder's read range is measured in meters.
- **Static Data Entry:** The information on the barcode cannot change once it has been printed. The information associated with an RFID transponder can be rewritten.
- **Data Volume:** An 8 kB RFID transponder contains five times the amount of data recorded on a standard barcode.
- **Item Level Tracking:** A barcode only identifies the product group. An RFID transponder can store multiple characteristics about the specific item within the product group.
- **Simultaneous Data Capture:** Only one barcode can be read at a time. Most RFID readers can identify and capture data from multiple transponders at the same time.
- **Durable for Harsh Environments:** Barcodes, typically printed on paper, are highly susceptible to damage from the surrounding environment (e.g. rain, UV exposure, chemical attack). RFID transponders can be upgraded to resist many environmental hazards.

Even considering the list of advantages presented above, it is not anticipated that RFID will completely replace barcode technology in the near future. Instead, the combined use of barcodes and RFID is the most probably outcome (Hedgepeth, 2007).

### **2.3.1.3 RFID Technology Adoption**

Even as rapid advancements in RFID technology were made during the 1990's, its use was still quite limited. The main reason impeding RFID's widespread adoption was cost; in some cases this continues to be the technology's primary draw back (Hedgepeth, 2007). It was not until the early 2000's that interest in RFID began to increase. Wal-Mart Stores, Inc. (Wal-Mart) and the United States Department of Defense (DOD) constitute the primary driving force behind the adoption of RFID in the past decade (it should be noted that Wal-Mart was the driving force behind the adoption of the barcode in the 1970's). Both organizations mandated that their top suppliers begin to use passive RFID transponders at the pallet level beginning in 2005 (Hedgepeth, 2007; Myerson, 2007; Shepard, 2005; Lehpamer, 2008). The impact of this requirement is realized when one considers that when combined, Wal-Mart and the U.S. DOD make up the largest purchasers of domestic and foreign goods in the United States (Hedgepeth, 2007). Other organizations have since implemented similar mandates for their suppliers (Myerson, 2007). While not all of Wal-Mart's or the U.S. DOD's suppliers have fully implemented RFID, both organizations have benefitted from what adoption of the technology has taken place. Wal-Mart claims a 30% reduction in out-of-stock merchandise and reduced excess inventory in the supply chain (Lehpamer, 2008). The U.S. DOD has concluded that implementing RFID will optimize the military supply chain, but only if it is applied at all levels (Hedgepeth, 2007). Both Wal-Mart and the U.S. DOD have a lot to benefit from any technology which may lead to an increase in the efficiency of their inventory management systems; the construction industry is no different.

### **2.3.2 Global Positioning System (GPS)**

The Global Positioning System (GPS) is currently a widely used system that allows a variety of users to accurately identify their position, monitor their velocity or ascertain the exact time from almost any point on or near the earth's surface (Logsdon, 1995). The development of

GPS began in the early 1960's by a number of U.S. government agencies that had a shared interest in developing a spaced based radio navigational system for military purposes. The goal of the system was to provide highly accurate positional data to dynamic users on a continual basis regardless of their global position (Kaplan, 1996). This need lead to the development of the U.S. Navy's TRANSIT satellite system (the Soviet Union developed a similar satellite system called Tsikada). However, TRANSIT suffered from two major drawbacks in that the time between the satellite signals received was quite high (90 minutes) and only relatively low accuracy position estimates could be attained. These deficiencies in TRANSIT lead to the development of the NAVSTAR Global Positioning System (Kaplan, 1996; Hofmann-Wellenhof, Lichtenegger, & Collins, 2001).

### **2.3.2.1 NAVSTAR GPS**

The Navigation System with Timing and Ranging (NAVSTAR) Global Positioning System is what is commonly referred to today as simply GPS. GPS is a satellite-based radio navigation system that became fully operational in 1995 (Kaplan, 1996; Hofmann-Wellenhof, Lichtenegger, & Collins, 2001). This system, which provides global navigation assistance to users regardless of their global location, is composed of three segments: the space segment, the control segment, and the user segment (Logsdon, 1995; Kaplan, 1996; Hofmann-Wellenhof, Lichtenegger, & Collins, 2001). Each of these segments is discussed separately below. It should be noted that Russia, the European Union, China, and India also have or are developing their own similar satellite-based navigation systems.

#### **2.3.2.1.1 Space Segment**

The space segment of GPS is composed of 24 earth orbiting satellites, as well as 4 back up satellites, operating at an altitude of 20,200 km. This group of satellites forms a constellation around the earth, which is divided evenly into 6 planes of 4 satellites each (Logsdon, 1995;

Kaplan, 1996; Hofmann-Wellenhof, Lichtenegger, & Collins, 2001). The purpose of the space segment is to supply accurately timed pulses or signals to users on or near the earth's surface. In the initial operating stages of GPS there were two primary types of signals being broadcast by the satellites. The first signal type, referred to as Coarse Acquisition Code (C/A-Code) was intended for all users but was hampered by encryption that lowered the position estimate accuracy to within approximately 100 m. The second signal type being broadcast referred to as Precision Code (P-Code) was intended strictly for use by the U.S. military and provided position estimate accuracy to within approximately 20 m (Logsdon, 1995; Kaplan, 1996). The Selective Availability policy of restricting the level of accuracy for non-military users was officially cancelled in May of 2000. However, the U.S. government still maintains the ability to restrict the accuracy of GPS signals through the use of encryption and jamming technology (Hofmann-Wellenhof, Lichtenegger, & Collins, 2001).

#### **2.3.2.1.2 Control Segment**

The control segment of GPS is made up of a master control station, 5 monitoring stations, and 3 ground control stations spread around the globe. The purpose of the control segment is to track the satellites, ensure the accuracy of the time clocks on board each satellite, and to upload periodic updates to them as needed (Hofmann-Wellenhof, Lichtenegger, & Collins, 2001).

#### **2.3.2.1.3 User Segment**

The user segment of GPS is anyone on or near the earth's surface attempting to fix their position, monitor their velocity, or determine the correct time using a GPS receiver (Logsdon, 1995). To function correctly a receiver must lock on to the signal of at least 4 or more GPS satellites at one time. 3 of the 4 signals are used to calculate the spatial position of

the user in 3D. The 4<sup>th</sup> signal is used to calculate the time delay between when the signal pulses were sent and received. This allows for corrections to the position estimate to be made by the GPS receiver. The overall importance of time in the calculation of a position estimate using GPS is why each satellite carries a highly accurate atomic clock and why those clocks are then synchronized on a daily or twice daily basis with clocks on earth at each ground control station (Logsdon, 1995; Kaplan, 1996; Hofmann-Wellenhof, Lichtenegger, & Collins, 2001).

### **2.3.2.2 GPS Applications**

With the removal of Selective Availability, the level of position accuracy attainable is now only a factor of a user's investment in a receiver. As such the number of applications for GPS is almost too large to list. The utilization of GPS for navigation purposes is most common and is not restricted to ships or planes but can now be implemented in personal automobiles for relatively low cost. The integration of these dashboard GPS systems with Intelligent Traffic Management Systems is also becoming more common. The application of GPS on the battlefield, the environment for which the system was initially developed, cannot go unmentioned. It is not uncommon for individual soldiers to be affixed with highly intelligent GPS transceivers, which allow for their commanders to watch over their every movement. The use of GPS in land surveying is also a common practice and is heavily applied in the construction industry and in the field of Geographic Information Science. Another important use of GPS today is the increased ability of suppliers and purchasers alike to accurately locate their material and equipment as it moves through the supply chain. The application of GPS in this fashion is only now beginning to be explored in the construction industry.

### **2.3.3 AMLTT & the Construction Industry**

The use of RFID and GPS to locate and track construction material and equipment has evolved over the past 15 years from the initial concept stage to full scale field trials. The use of RFID, in particular, for tracking the delivery and handling of material to a construction site and also for tracking labour and equipment on site was first proposed in 1995. However, the construction industry, like other industries at the time, did not widely pursue the adoption of RFID due to the high cost of implementation and lack of technology standardization (Jaselskis, Anderson, Jahren, Rodriguez, & Njos, 1995). Further attention was given to the application of RFID in the construction industry in 1998. The Construction Industry Institute (CII), based at the University of Texas at Austin, held an RFID workshop with members of the construction industry, academia, and RFID technology developers and suppliers in attendance (Jaselskis & El-Misalami, 2003). Much of the research regarding the use of RFID in construction originated from this industry workshop.

The initial research steps taken focused on validating the ability of RFID to function on a construction site and demonstrating the usefulness of the technology in general to the industry. Jaselskis and El-Misalami (2003) investigated the use of RFID technology to assist in receiving material at two industrial construction projects. The use of RFID in this fashion was proposed as part of the CII workshop in 1998. In the first test completed, passive RFID tags were attached to a series of pipe supports. The time it took a worker to receive a tagged and untagged pipe support was compared. The result of this test was a reduction in the variability of the time it took a worker to receive a tagged pipe support versus an untagged one. The number of workers required to perform this task was also able to be reduced from 2 to 1. In the second test, the researchers affixed an RFID tag to 100 line items (a line item was usually composed of a number of individual parts). A number of problems were encountered during this experiment. It was not uncommon for the components which made

up a single line item to be spread over a number of pallets, which resulted in some confusion for the workers trying to accurately receive the material into their material database (Jaselskis & El-Misalami, 2003). While the first test demonstrated the ability of RFID to improve productivity of the material receiving process, the results of the second test emphasized the need for further work in this area, especially in regards to exposure and training of the worker at the craft level to this form of technology. The results also demonstrated that the characteristics of a typical construction project pose a much different operating environment than that of other industries where RFID is currently being implemented.

Moving forward, the research community began to focus specifically on determining the ability to accurately identify and track key equipment and materials using RFID in typical construction environments. The reason for this step being that if RFID technology, as it currently stood, could not function with a reasonable amount of reliability in a dynamic and often physically harsh environment such as can be found on a construction site then perhaps it was not yet ready to be applied in this particular industry. Goodrum, McLaren, & Durfee (2006) explored the ability of active RFID transponders to track hand held tools on construction sites. Modified RFID tags were inserted inside the handles of common hand tools typically found on constructions sites (i.e. hammer drill, portable band saw, & reciprocating saw). Tests were then performed to evaluate the read range of the signal of the RFID tags inserted in the tools. The read range of the tags was found to vary from site to site. This variability was attributed to inherent inconsistency in the tags themselves, the quantity of metal objects in the surrounding environment (metal impedes the propagation of radio waves), and the effect of cold temperatures (Goodrum, McLaren, & Durfee, 2006). However, the results did demonstrate that RFID could successfully be used to track tools in a construction environment.



Song, Haas, Caldas, Ergen, & Akinici (2006) focused on determining the feasibility of using RFID technology to automatically identify fabricated pipe spools. The first phase of the tests focused on investigating the ability of handheld and fixed RFID readers to receive the signals from active RFID tags in a construction laydown yard or warehouse setting. The second phase of field trials performed examined the use of fixed RFID readers to automatically identify fabricated pipe spools loaded on a flatbed trailer as they passed through a portal (i.e. as if they were being delivered to site from the fabricator). The results of both phases of the trials were positive; the commercial RFID technology employed was able to accurately identify the tagged items within an acceptable tolerance level (Song, Haas, Caldas, Ergen, & Akinici, 2006).

The results of the studies presented above demonstrated that commercially available RFID technology could be applied in a construction setting and achieve acceptable results. In each case some difficulties were encountered when applying RFID in the field, but this was to be expected with the integration of any new technology into an already established system. The most commonly cited problems included a lack of standardized equipment and the need for members of the construction industry (at all levels) to be introduced and exposed to RFID technology (Jaselskis & El-Misalami, 2003; Goodrum, McLaren, & Durfee, 2006). More importantly, were the tangible results that indicated RFID could be used to successfully identify and track material and equipment in a construction environment (Jaselskis & El-Misalami, 2003; Goodrum, McLaren, & Durfee, 2006; Song, Haas, Caldas, Ergen, & Akinici, 2006).

With the ability of RFID technology to perform in a construction environment established significant research efforts have and continue to be put forth in developing the ability to automatically locate and track construction materials (AMLT). To be able to successful achieve both facets of AMLT (i.e. tracking and locating) the integration of RFID and GPS is

required (hence AMLTT). Song, Haas, & Caldas (2006) proposed the ‘Rover’ approach to automating the tracking of the location of construction materials. The principle idea is that a worker equipped with both RFID and GPS receivers roves through a construction warehouse or laydown yard in which materials would be affixed with RFID tags. As the signals from transponders are picked up at different points by the receiver throughout the roving pattern, an algorithm processing in the background narrows down the possible area in which the RFID tag could be located in relation to the location of the receiver (determined using GPS). The specific mathematical model applied in this approach is called the Method of Constraints (Song, Haas, & Caldas, 2006). Note, the formulation of location algorithms is beyond the scope of this thesis. Field experiments were conducted using the Rover approach in which parameters such as the radio frequency (rf) power emitted by a reader, the number of tags placed in the test area, the pattern of the placement of tags, and the number of reads generated were considered. The results of various field experiments using the Rover locating method were successful in automatically identifying the location of specific RFID tags. Specifically, the calculated tag location was found to be within 3 to 4m of the actual tag location (Song, Haas, & Caldas, 2006).

Caron et al (2007) and Torrent & Caldas (2007) have also completed work on analyzing location algorithms for use with AMLTT. In Caron et al (2007) 6 location models were compared. The models included the Method of Constraints, Manual Searching and Mapping using GPS and GIS, Accumulation Arrays, Dempster-Shafer, Fuzzy Logic, and Triangulation based on transmission space. The models listed were compared based on cost of implementation, flexibility of use, scalability, computational complexity, the ability to handle uncertainty, and response to dynamic sensor arrays (i.e. moving RFID tags) (Caron, et al., 2007). Torrent & Caldas (2007) focused on comparing the Centroid and Proximity location algorithms in a construction like environment (i.e. buildings and other obstacles located in

test area). RFID tags were attached to 10 metallic spools that were spread throughout the test area. The results of the completed tests indicated that the Centroid algorithm estimated the location of the tagged spool more accurately than the Proximity algorithm ( $\pm 2.7\text{m}$  vs.  $\pm 5.4\text{m}$ ) (Torrent & Caldas, 2007). At first glance, the location accuracy achieved so far by the location algorithms implemented in the studies above may seem low (i.e.  $>1\text{m}$ ). However, the ability to automatically locate material or equipment in laydown yards, which are often measured in 1000's of square meters, with even such precision is a great improvement over the manual method of searching currently employed. Furthermore, work in improving the accuracy of location algorithms for AMLTT is continuing at both the academic and industry levels.

While some researchers have focused on developing and comparing location algorithms, others have focused on implementing prototype AMLTT systems in construction project environments. Ergen, Akinci, & Sacks (2007) applied AMLTT in the storage yard of pre-cast concrete manufacturer. The pre-cast concrete industry is one sector of construction that does rely on applying JIT delivery for their clients, often due to limited storage space requirements of 'downtown' projects (i.e. high rise building developments). The use of AMLTT presented the possibility to improve the efficiency of locating specific pre-cast elements within the fabricator's storage yard and in turn improving their delivery process as well (Ergen, Akinci, & Sacks, 2007). In this field trial RFID tags were placed on precast T-beams and a RFID and GPS reader were mounted on a mobile gantry crane. A series of relocations of the tagged precast elements were performed within the storage yard. 61% of the relocations were identified by the prototype AMLT system within acceptable limits (Ergen, Akinci, & Sacks, 2007).

Razavi et al (2008) implemented AMLTT on a limited scale on a power plant construction project. At the outset of the research project, the general contractor and members of the

research team identified a series of key materials to be monitored using AMLTT. The materials selected included 240 pipe spools for one of the two generating units being constructed, 100 globe valves, and 22 safety valves. An active RFID tag was attached to each item as it arrived on site and its location was monitored using AMLTT until it was installed within the facility. The on-site research team member was able to use the location data collected using AMLTT to assist on-site contractors in reducing the amount of time spent searching for lost items, which resulted in a significant cost savings for the project (> \$50,000) (Razavi, et al., 2008).

While both of the field trials mentioned above were successful in demonstrating the potential for AMLTT to have a beneficial impact on their individual projects, it became evident to some researchers that a blanket approach could not be taken with regards to the implementation of AMLTT within the construction industry. As was discussed in the forgoing sections, the overall unique nature of construction projects typically inhibits any such approach. Stemming from the same field trial as described in Razavi et al (2008), Nasir (2008) proposed a multi-step implementation model for incorporating AMLTT within the construction materials management process. The proposed implementation model is composed of 7 sequential steps: 1) identification of project needs, 2) project definition, 3) establishment of an evaluation criteria, 4) development of implementation options, 5) evaluation of those options, 6) process implementation, and 7) performance evaluation and capturing lessons learned (Nasir, 2008). Of particular interest was the discussion surrounding step 5, which included the presentation of a sample cost-benefit analysis of three different AMLTT configurations. Nasir (2008) estimated a benefit/cost ratio of between 6 and 17 to 1, depending on the scale of adoption, in favour of AMLTT if implemented on a typical industrial construction project. It should be noted that Nasir's (2008) estimates of the potential benefits of AMLTT agrees well with the internal estimates of a number of industry

members. Overall, the work completed by Nasir (2008) further highlighted the need to consider the implications of AMLTT on the construction process from a broader perspective.

The development of AMLTT has been presented from the initial concept stage to the point at which it has been successfully implemented at the field trial level. With these initial research steps completed and in some cases continuing, what remains unaddressed is an understanding of the overall impact that AMLTT could have if implemented on a larger scale, such as throughout the construction supply network of a project (i.e. from the point of fabrication to the point of installation). This knowledge from a construction perspective is important, for as has previously been indicated, theories, methods, and results from other industries cannot always be directly applied to the construction industry and achieve the same success. The aim of this thesis is to shed some light on this area of research, which has yet to be fully examined.

## **2.4 Simulation**

This purpose of this section is to present the relevant background information and evidence from literature that supports the use of simulation as an effective method of analysis of construction processes. The first part of the discussion will define simulation and list a number of pertinent advantages that it offers to the decision maker. The use of simulation as an analysis tool in the construction industry will then be presented. This portion of the discussion will also touch briefly upon the development of construction specific simulation platforms. Finally, the specific application of simulation to analyze construction supply networks will be discussed.

### **2.4.1 Simulation & Its Advantages**

Simulation can be described as a process by which the operation of a real process or system is reproduced over a period of time (Banks, 1998). The recreation of the system is

accomplished by utilizing actual recorded or artificially generated data to model the characteristics of the different components of the system. When these components are combined into one overall system model, a perspective of how the system functions as a whole can be created.

Simulation provides the decision maker with a number of advantages as an analysis tool and Banks (1998) has identified some of the most prominent of them:

- **Minimize Risk:** Simulation allows for changes to an existing system to be analyzed without the risk of incurring potentially negative impacts on the real world system.
- **Ability to ‘Play’ with Time:** Simulation provides the ability to ‘play’ with time allowing for events of the past to be examined just as easily as possible events that may not occur for several months or years.
- **Examination in Detail:** System phenomena can be identified and examined in great detail using simulation.
- **Identify Constraints:** Constraints hampering the smooth operation of a system can be easily identified and quantified using simulation.
- **Visualization:** Systems which are spread across large areas or distances (i.e. factory or supply chain) can be easily visualized as a whole using simulation.
- **Invest Wisely:** Simulation is a relatively inexpensive means of system analysis.

It is for these advantages and others that the use of simulation is widespread across a variety of industry sectors including: government, health, manufacturing, military, and transportation (Banks, 1998). While the use of simulation in the construction industry is limited, it plays a significant role in research applications as shall be discussed below.

## **2.4.2 Simulation & the Construction Industry**

The use of simulation in the construction industry has evolved out of a need to be able to design and analyze construction processes, especially those on large scale projects. The advancements in computing technology in the last half of the 20<sup>th</sup> century have made this possible (AbouRizk, Halpin, & Lutz, 1992; Sawhney, AbouRizk, & Halpin, 1998). The first construction specific simulation platform was developed by Teicholz in 1963, which used a link node model for studying construction operations. This was followed a decade later by the development of CYCLONE (Cyclic Operation Network) by Halpin (AbouRizk, Halpin, & Lutz, 1992; Halpin & Riggs, 1992; Sawhney, AbouRizk, & Halpin, 1998). Other construction simulation platforms, such as STROBOSCOPE and EZStrobe both developed by Martinez (1996, 2001), were based on the CYCLONE platform. The success of these simulation platforms was based on the relative ease in which the developed process models and the subsequent results could be understood by both academics and members of the construction industry (AbouRizk, Halpin, & Lutz, 1992).

Simulation is used by various sectors of the construction industry, especially those that routinely deal with processes that are highly repetitive or cyclic in nature. These industry segments include, but are not limited to: heavy civil operations (e.g. earth moving, & road construction), tunnel excavation, transportation design (i.e. road and rail networks), and heavy lifting operations (Halpin & Martinez, 1999). When utilized throughout the lifespan of a project, simulation and the generated results can be applied in many different ways. During the initial phases of project development, simulation can be an effective planning and estimating tool. As construction progresses, simulation of work processes can be used to generate productivity baselines. During the later stages of a project, simulation can be used to perform cost analysis and assist in dispute resolution (Halpin & Martinez, 1999).

Numerous examples of the successful use of simulation in analyzing construction processes can be easily found in literature. Halpin & Martinez (1999) describe a concrete caisson fabrication operation that was modeled using the PROSIDYC simulation system. Using PROSIDYC two new alternate construction processes were developed. The simulation results estimated an increase in productivity of 24% and 38% for the two alternatives, respectively, over the original process design (Halpin & Martinez, 1999). Sawhney, Mund, & Marble (1999) simulated the steel erection process for a hospital redevelopment project. During their initial investigation the researchers were able to identify that the size of the steel decking crew was a critical resource (Sawhney, Mund, & Marble, 1999). As previously mentioned, Tommelein (1998) and Al-Sudairi et al (1999) studied the impact of lean construction on construction processes using simulation with some success. Halpin & Kueckmann (2002) completed similar work. Ruwanpura et al (2001) analyzed a tunnel construction project in Edmonton, AB, using discrete event simulation. In addition to allowing for multiple construction strategies to be tested and validated, using simulation allowed the City of Edmonton to produce a more realistic project schedule and cost estimate (Ruwanpura, AbouRizk, Er, & Fernando, 2001). The examples presented above give some indication as to the potential benefits that can be achieved by employing simulation to analyze a variety of construction processes. As computing power and especially the capability to generate 3D images continue to increase, the employment of simulation platforms to analyze and evaluate construction strategies will continue to increase as well.

#### **2.4.2.1 Analysis of Construction Supply Networks Using Simulation**

The body of knowledge surrounding the analysis of construction supply networks using simulation is somewhat limited. A significant research effort on simulation and supply chain analysis was conducted during the latter part of the 20<sup>th</sup> century, but the focus was predominately on the manufacturing sector. The construction supply network models



developed were often based on manufacturing principles that did not truly depict the characteristics of the actual system (O'Brien, London, & Vrijhoef, 2002). The complexity of the construction process, for many of the reasons previously noted in Section 2.2, has been identified as the primary obstacle to be overcome in simulating the construction supply networks (O'Brien, London, & Vrijhoef, 2002). The development of the supply network models presented as part of this thesis attempt to overcome this obstacle by building them from the perspective of the construction industry first and not from a manufacturing standpoint followed by a later attempt to incorporate the unique characteristics of the construction process.

## **Chapter 3**

### **Formulated Simulation Models**

#### **3.1 General**

The purpose of this chapter is to present the formulated simulation models for the three areas of the construction supply network being investigated: 1) the on-site material receiving process, 2) the task of locating material and equipment in a construction laydown yard, and 3) increasing visibility within the construction supply network. These focal points were chosen for study primarily because of current efforts to introduce AMLTT into the specific process or due to the foreseen potential for AMLTT to have significant impacts on improving the management of the construction supply network as a whole.

This chapter has been divided into a number of sections. The first section will introduce two field trials in which the impact of AMLTT on materials management at the site level was studied. The results of these field trials have been briefly touched upon in Chapter 2 (Torrent & Caldas, 2007; Razavi, et al., 2008). However, since the author's own direct involvement in these field trials has provided much of the motivation, understanding, and foundation for the process models presented in this chapter, it was felt that it would be pertinent to provide the reader with an additional sense of grounding. The next section will provide an overview of the modeling and simulation platform used to formulate the various models. The subsequent sections will each cover one of the areas of the construction supply network under investigation. These sections will provide an overview of the subject area in question and describe the developed simulation models in detail. In each case, a minimum of two simulation models were developed. The first simulation model represents the existing process or situation as it typically exists in the construction industry today. The subsequent model(s) represents a modified version of the existing process model in which AMLTT has

been included. The simulation results and the corresponding analysis are presented in the next chapter.

### **3.2 Field Trials**

The results of two field trials, which were conducted to investigate the possible impacts of AMLTT on construction productivity, serve as the basis for the simulation models presented in this chapter. The field trials were conducted as part of the work of CII Research Team 240 (RT-240). RT-240's overall scope of research was to examine and quantify the influence that different technologies (i.e. equipment, material, and information) have had or could have on construction productivity. The field trials were conducted at power plant construction projects in Rockdale, Texas and in Toronto, Ontario, respectively (Construction Industry Institute, 2008). A number of objectives to be met as part of the scope of work of both field trials were outlined by RT-240. The research objectives which directly apply to this thesis included (Construction Industry Institute, 2008):

- Assess the impact of a material identification and locating technology on labor and construction productivity;
- Capture lessons learned regarding technology implementation issues and use during the trials.

The completion of these objectives over the course of both field trials provided much of the foundation for which the subsequent simulation models are based.

A research team based at the University of Waterloo, which the author was a member of, was primarily responsible for facilitating the Toronto field trial. A sister research team at the University of Texas at Austin was responsible for the Rockdale field trial. Additional support for the field trials was also provided by researchers at the University of Kentucky and by the industry members of RT-240. Both field trials are described separately below.

### 3.2.1 Rockdale Field Trial

The Rockdale field trial was conducted at the Sandow Steam Electric Station Unit 5 project, which is operated by Luminant Energy. The project's general contractor was Bechtel Corporation. The Rockdale facility is a circulating fluidized bed, lignite-fired power plant, with a total generating capacity of 565 MW. The facility is composed of two boiler units, two bag houses, a single exhaust stack, and a single turbine (Construction Industry Institute, 2008). Figure 3.1 shows the facility under construction during the summer of 2007.



**Figure 3.1 – Sandow Steam Electric Station (June 2007) (Photo Credits: S. N. Razavi)**

The Rockdale field trial, conducted between August 1 and October 19, 2007, implemented AMLTT within the existing site materials identification process. The construction of the boiler units required the erection of two near identical steel structures. The steel components required for these structures were stored in a 25 acre ( $\pm 101 \times 10^3 \text{ m}^2$ ) laydown yard, located approximately 1000 ft (305 m) from the installation area. The laydown yard was subdivided into numbered grids of approximately 50 x 100 ft (15 x 30 m). The locations of the items stored in the laydown yard were recorded based on this grid system. When a request for

material in the laydown yard was made, workers would locate and flag the requested items, facilitating their recovery and transfer to the work face by craft workers. As part of the completed field trial, 400 steel components required for installation within the structure for Boiler B were tagged with active RFID transponders. The locations of these items within the laydown yard were tracked using the integration of GPS and RFID (i.e. AMLTT). When a request for some of these items was made, a map indicating their most recent recorded locations within the laydown yard was produced and provided to the workers. The locations of these steel components would continue to be tracked in the install area up to the point of erection. No form of identification or location monitoring of components at the work face had previously been implemented. The locations of 400 comparable steel components for Boiler A were also monitored for comparison purposes. The following key results were recorded as part of the Rockdale field trials:

- The average time to locate untagged steel components for Boiler A was 36.8 minutes, where as the average time to locate the tagged components for Boiler B was 4.6 minutes;
- 19% of the tagged materials were moved more than once;
- Productivity in the install area of Boiler B was increased by 4.2%. The increase in productivity was attributed to certainty in component locations at the work face.

Overall, the Rockdale field trial was successful in demonstrating the ability of AMLTT to increase construction productivity (Construction Industry Institute, 2008).

### **3.2.2 Portlands Field Trial**

The second field trial was conducted at the Portlands Energy Center (PEC) project, located in the port area of Toronto, Ontario. PEC is a joint venture between Ontario Power Generation Inc. (OPG) and TransCanada Energy Ltd. The general contractor for the project was SNC-

Lavalin Power Ontario Inc. The facility has a total generating capacity of 550 MW, which is achieved using two natural gas fired, combined cycle, generator and steam turbine units. Photos of the facility under construction and near completion are shown in Figure 3.2 and Figure 3.3, respectively.



**Figure 3.2 – Portlands Energy Center (November 2007)**



**Figure 3.3 – Portlands Energy Center (June 2008)**

Coordination activities for the PEC field trial began in the late spring of 2007, with the field trial beginning in earnest in August 2007. The focus of the PEC field trial, like Rockdale, was to investigate the impact of AMLTT on construction productivity. Unlike Rockdale, the PEC project did not operate one single large laydown yard location, but instead maintained storage space at the Port of Toronto and in various locations distributed around the project site, including a central temporary warehouse. The lack of a single laydown yard was as a result of limited free space on and around the project site. As a result, control of material was distributed between the general contractor and the various sub-contractors. At the outset of the field trial a series of 200 pipe spools for the Unit 2 Boiler and a number of specialty valves were identified as suitable candidates for monitoring using AMLTT. These items were selected based on the recommendation of the construction management team, due to the tendency for losses in productivity to occur as a result of their mismanagement on site. The selected items were each affixed with an active RFID transponder and their locations monitored using AMLTT.

The sub-contractors involved in the PEC field trial initially resisted the assistance offered by the research team in locating material. It was perceived by members of the research team that the contractors had an overall lack of confidence in the potential for AMLTT to increase the efficiency of their operations. Some progress was achieved, however, after the research team was able to successfully locate a number of pipe spools for one of the sub-contractors. The sub-contractor had previously invested a significant amount of time and crew resources in locating the same pipe spools without any success. This particular sub-contractor (Contractor A) quickly appreciated the benefit of AMLTT and began requesting material locates from the research team prior to beginning lengthy manual searches. The other principle sub-contractor (Contractor B) involved in the field trial infrequently took advantage of the services offered by the research team; usually only as a last resort. The primary

observations collected during the field trial activities at PEC during the summer and fall of 2007 are summarized as follows (Construction Industry Institute, 2008):

- Contractor A readily appreciated the benefits of AMLTT and was satisfied with the level of location accuracy that could be achieved;
- It was estimated that each material locate was able to save the project between \$4000 and \$5000;
- Contractor A was able to reduce their initial crew size from 18 to 12, due to increased confidence in material location information;
- Contractor B only utilized the available material location information as a last resort.

Overall, due to the realized and perceived benefits of AMLTT, the PEC site manager decided to maintain a research team presence on the project beyond the initially established time frame of the fall of 2007. Two University of Waterloo undergraduate Civil Engineering co-op students were employed by SNC-Lavalin for the winter and summer of 2008 in a support role for the project's materials management team. The author was directly involved in the PEC field trial between August and December 2007 and provided assistance as required to the other students on site.

### **3.3 EZStrobe: General-Purpose Simulation System**

The EZStrobe: General-Purpose Simulation System (EZStrobe) was utilized to build the construction supply network models that form the basis for this thesis. This particular simulation platform was chosen as it allows the user to model reasonably complex processes, without the necessity of learning a complex coding syntax. EZStrobe also provides the ability to model the impact of and record the response to: different arrival patterns, resource







constraints, process changes, activity durations, and changes due to the incorporation of new technologies with very little difficulty.

EZStrobe is a discrete event simulation environment that is based on the STROBOSCOPE simulation platform, both of which were developed by Martinez (1996, 2001). Discrete event simulation focuses on capturing and analyzing the movement or flow of entities through a specific process or network. The movement of these entities through the various stages of a network (i.e. the transfer of excavated soil from the borrow site to the embankment site or the fabrication of a pipe spool) can be considered to occur at discrete instances in time. If the start and end times of the movement of an entity through a particular stage of the network can be recorded, an inference of the location of that entity can be made (Halpin & Riggs, 1992). This is the underlying concept behind how Discrete Event Simulation platforms function.

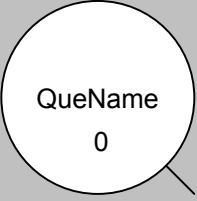
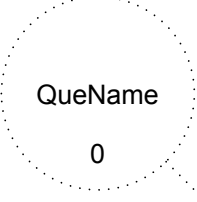
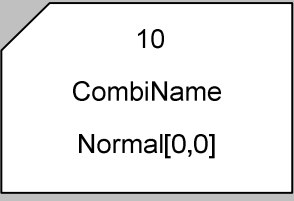
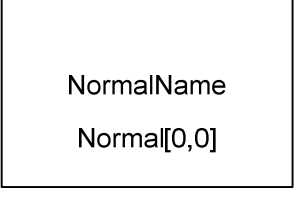
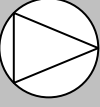
Like similar simulation platforms (e.g. CYCLONE & STROBOSCOPE), EZStrobe employs a series of visual elements, referred to as Activity Cycle Diagrams (ACD's), to depict the logic of the model (Martinez, 2001). These elements, when combined in a network, are used to represent resources, activities, and the interactions between them. As is the case in other computer coding languages, there are certain limitations and relationships that must be adhered to when building a simulation model in EZStrobe. One of the benefits of EZStrobe is that the learning curve for understanding its modeling language is quite rapid. A summary of the EZStrobe ACD's and their associated operating conditions are outlined in Table 3.1. In the subsequent sections, the developed simulation models are presented and explained in terms of the EZStrobe elements described below. For further reference material on EZStrobe and its associated syntax the reader is directed to *EZStrobe - General-Purpose Simulation System Based on Activity Cycle Diagrams* by Martinez (2001).

**Table 3.1 – EZStrobe Modeling Elements**

Element Name	Activity Cycle Diagram	Description
<b>Queue</b>		<ul style="list-style-type: none"> <li>• An element that contains resources waiting to be removed by the activation of a Combi Activity.</li> <li>• Resources can be added to a Queue by preceeding activities.</li> <li>• Element name and the quantity of resources stored at a given instance in time are displayed as shown at left.</li> <li>• A Queue can follow any activity, but it must precede a Combi Activity.</li> </ul>
<b>Fusion Queue</b>		<ul style="list-style-type: none"> <li>• An element that allows for resources to be passed from one worksheet to another or within a worksheet without the use of link</li> <li>• Assumes the initial properties as the Queue named</li> <li>• Same precedence rule as a normal Queue</li> </ul>
<b>Combi Activity</b>		<ul style="list-style-type: none"> <li>• An activity that can only begin if specific resource constraints have been satisfied.</li> <li>• Priority ranking, element name, and activity duration are displayed as shown at left.</li> <li>• Activities assigned a higher ranking are given priority.</li> <li>• A Combi can only follow a Queue, but it can precede any other element except another Combi.</li> </ul>
<b>Normal Activity</b>		<ul style="list-style-type: none"> <li>• An activity that can begin as soon as the previous activity has been completed (i.e. no resource constraints must be met)</li> <li>• Element name and activity duration are displayed as shown at left.</li> <li>• A Normal can follow any element except a Queue and can precede any element except a Combi.</li> </ul>
<b>Fork</b>		<ul style="list-style-type: none"> <li>• Allows for probability based decisions to be modeled.</li> <li>• An unlimited number of probability paths can originate from a single fork (<math>\sum P_i = 1</math>).</li> <li>• A fork can follow any node except a Queue.</li> <li>• Multiple forks can be linked in series.</li> </ul>
<b>Draw Link</b>		<ul style="list-style-type: none"> <li>• Connects a Queue to a Combi Activity.</li> <li>• In-line information denotes the Queue quantity constraint that must be satisfied (<math>&gt;0</math>) prior to allowing the connected Combi to draw the specified amount (1).</li> <li>• <math>&gt;</math> greater than, <math>&lt;</math> less than, <math>\geq</math> greater than or equal to, <math>\leq</math> less than or equal to, <math>=</math> equal, <math>\neq</math> not equal to.</li> </ul>
<b>Release Link</b>		<ul style="list-style-type: none"> <li>• Connects the termination point of one activity to the start point of another activity, except a Combi</li> <li>• In- line information denotes the number of units to be released upon completion of a given activity (1).</li> </ul>
<b>Branch Link</b>		<ul style="list-style-type: none"> <li>• Connects a Fork to another element, except a Combi.</li> <li>• In-line information denotes the probability that a specific branch will be chosen (<math>0 \leq P \leq 1</math>).</li> </ul>

In addition, simplified process models are frequently used within the text to provide the reader with a starting point to the discussion of the more complex EZStrobe process models. These model diagrams describe the same overall processes using fewer and more simplistic elements. The reader may find it helpful to refer to these models in the event that they become bogged down in the logic of a particular EZStrobe model.

### **3.4 On-site Material Receiving Process**

The material receiving process on a large construction project is typically the first point of contact for materials or engineered equipment when they arrive on site. Depending on the project location the various shipments may arrive via land, sea, air or via a combination of transportation modes. The shipments may come in a variety of shapes and sizes, ranging from exhaust stacks that occupy the entire deck space of a cargo ship to a specialty valve that arrives in a small cardboard box. These shipments deliver the numerous unique and often highly valuable pieces of material and equipment required during the construction of a facility. In each case, a warehouse or laydown yard crew is tasked with unloading a specific shipment and storing its contents in the appropriate location for retrieval at a later date. Next, a clerk or possibly members of the same warehouse crew must check each item received against the shipping manifesto. The recorded data is then entered into a materials management system (MMS) to facilitate payment and to maintain a record of receipt. As can be easily appreciated, the material receiving process on large construction projects requires a large investment of both labour and time, and in some cases equipment as well (e.g. forklift, crane). The accuracy in which this process is carried out is also crucial for ensuring that the right piece of equipment or material is made available in the future at the right point in the construction schedule.

### 3.4.1 Existing Material Receiving Process Model

Based on the description of the material receiving process outlined above, four distinct activities can be identified: 1) the arrival of shipments of goods to the site, 2) the offloading of those items for storage in the laydown yard or warehouse, 3) checking the items received against the shipping manifesto (aka ‘kicking out and counting’), and 4) entering data into the project MMS. These four activities form the core of the model developed to represent the existing material receiving process. A simplified process model, which illustrates the connection of the main process activities and the overall cyclic nature of the process, is depicted in Figure 3.4.

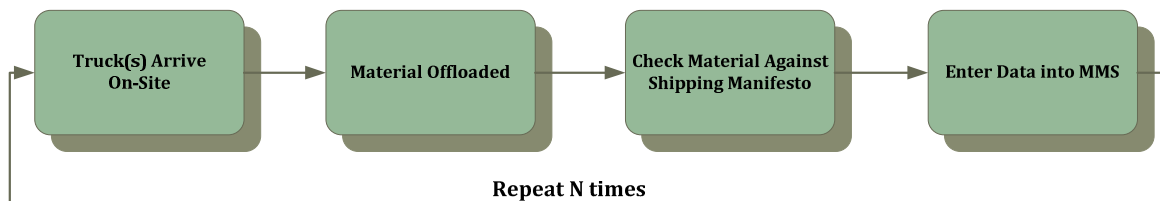

**Figure 3.4 – Simplified Existing Material Receiving Process**

To provide a frame of reference the development of the existing process model was based around receiving pipe spools to be installed as part of an industrial complex such as an oil refinery or power generation facility. The complete EZStrobe model is depicted in Figure 3.5. For the theoretical project being considered a quantity of pipe spools, which will arrive to the site in separate loads, must be offloaded, received, and entered into the MMS by the warehouse staff. The different stages of the existing process model are described below.

#### 3.4.1.1 Rate of Arrival of Loads to the Site

The arrival of loads to the site within the model is facilitated by the *TrucksArrive* combi activity. Based on past site experience, it is not uncommon for certain days to experience a large number of deliveries within a short period of time, while other days experience very

few deliveries. As such, the rate of arrival of trucks was varied in the subsequent analysis of the material receiving process, both existing and modified. The specific duration associated with the *TrucksArrive* activity element shown in Figure 3.5 corresponds to a rate of arrival of 4 trucks per day (i.e. one truck every 2.5 hours or 150 minutes). A working day is defined as a 10 hour period. To take into account possible variation in delivery time the duration was approximated using a Normal distribution with a mean of 150 minutes and a standard deviation of 22.5 minutes. The variation of the rate of arrival of deliveries will be discussed in further detail in Chapter 4.

In total, 2000 pipe spools were chosen to be delivered to the theoretical site. The pipe spools will be delivered to the site in loads of 20, resulting in 100 loads in total. In reality, it is not uncommon for 100 or more pipe spools to be delivered to the site from the fabricator in a single load, depending on their overall dimensions (i.e. smaller pipe spools results in increased number of spools per load). Therefore, the 20 pipe spools per load used here could represent individual spools of a size requiring that they must be offloaded one by one or bundles of spools that can be easily unloaded together.

#### **3.4.1.2 Offloading Material**

Offloading of the pipe spools from the trucks is represented by the *Offload* combi activity. For this activity to occur two conditions must first be satisfied. First, at least one truck must be available in the *Wait2Offload* queue. Second, the laydown yard work crew, which for the purposes of this model is composed of four workers (i.e. equipment operator and three additional crew members), must be available in the *WorkCrew* queue. Subsequently, only one load can be offloaded at a time. The duration assigned to offload a single load of pipe spools is based on the results presented by Jaselskis and El-Misalami (2003). As part of their study Jaselskis and El-Misalami (2003) completed a time study of the material receiving

process for pipe supports. A pipe support, as its name implies, is used to support a length of pipe spool at a desired elevation from a structural system. Average times to unload a crate of pipe supports were reported to be 1.1, 3.8, and 1.6 minutes ( $\mu \approx 2.2$  minutes) (Jaselskis & El-Misalami, 2003). The unloading of a pipe spool or group of pipe spools was not considered to require any additional time as compared to a crate of pipe supports as reported by Jaselskis and El-Misalami (2003). Both operations would require the use of a crane or other piece of equipment such as telehandler (i.e. Zoom Boom<sup>TM</sup>). Therefore, an average unloading time per piece of 2.2 minutes was used. This duration is considered to include attaching the required rigging, the swing time of the crane, the release and placement of the spools in a suitable position on the ground, and the return swing time of the crane. When multiplied for a complete load of 20 pipe spools, the total duration to unload a truck was taken to be 45 minutes. A Normal distribution with a mean of 45 minutes and a standard deviation of 7 minutes (15% of mean duration) was used to account for variation in the unloading process.

#### **3.4.1.3 Material Receiving Process**

The material receiving process is symbolized by the *RecMaterial* combi activity. Similar to the unloading process, two conditions must be satisfied for this activity to be enacted. An offloaded group of material must be available in the *Wait2Rec* queue and 2 of the 4 members of the work crew must be available. The selected duration to receive a load of material was again based on the time study completed by Jaselskis and El-Misalami (2003). They reported an average of 3.65 minutes to ‘kick out and count’ a pipe support (i.e. removal of an item from a crate and lay it out for counting). As the pipe spools in question are considered to be of a size in which they will not need to be ‘kicked out’, an average duration of 3 minutes to receive a pipe spool was used. When considering a complete load, 60 minutes in total was used. Again a Normal distribution was utilized to model the duration of this activity, with a mean of 60 minutes and a standard deviation of 9 minutes.

#### **3.4.1.4 Inputting Data into Materials Management System**

After it has been confirmed that all of the materials intended to be delivered have actually been received, this information must be entered into the project's MMS. This task is accomplished by the *InputData* combi activity in the model. For this activity to be completed the clerk must be available and a load must have been received. These two conditions are represented by the *Clerk* and *Wait2Input* queues, respectively. Jaselskis and El-Misalami (2003) provided the key piece of data for this activity duration as well. In this case, they reported an average of 0.56 minutes to input the required data into project's MMS. No change in activity duration was anticipated to upload similar information for a pipe spool as compared to a pipe support. Therefore, a Normal distribution of 12 minutes with a standard deviation of 2 minutes was used to model the duration of this activity. When this activity is completed, the load in question is considered to be fully received and available for installation. In most cases, the material remains in the project warehouse or laydown yard for a number days, weeks, or even months before being transferred to the work face for installation.

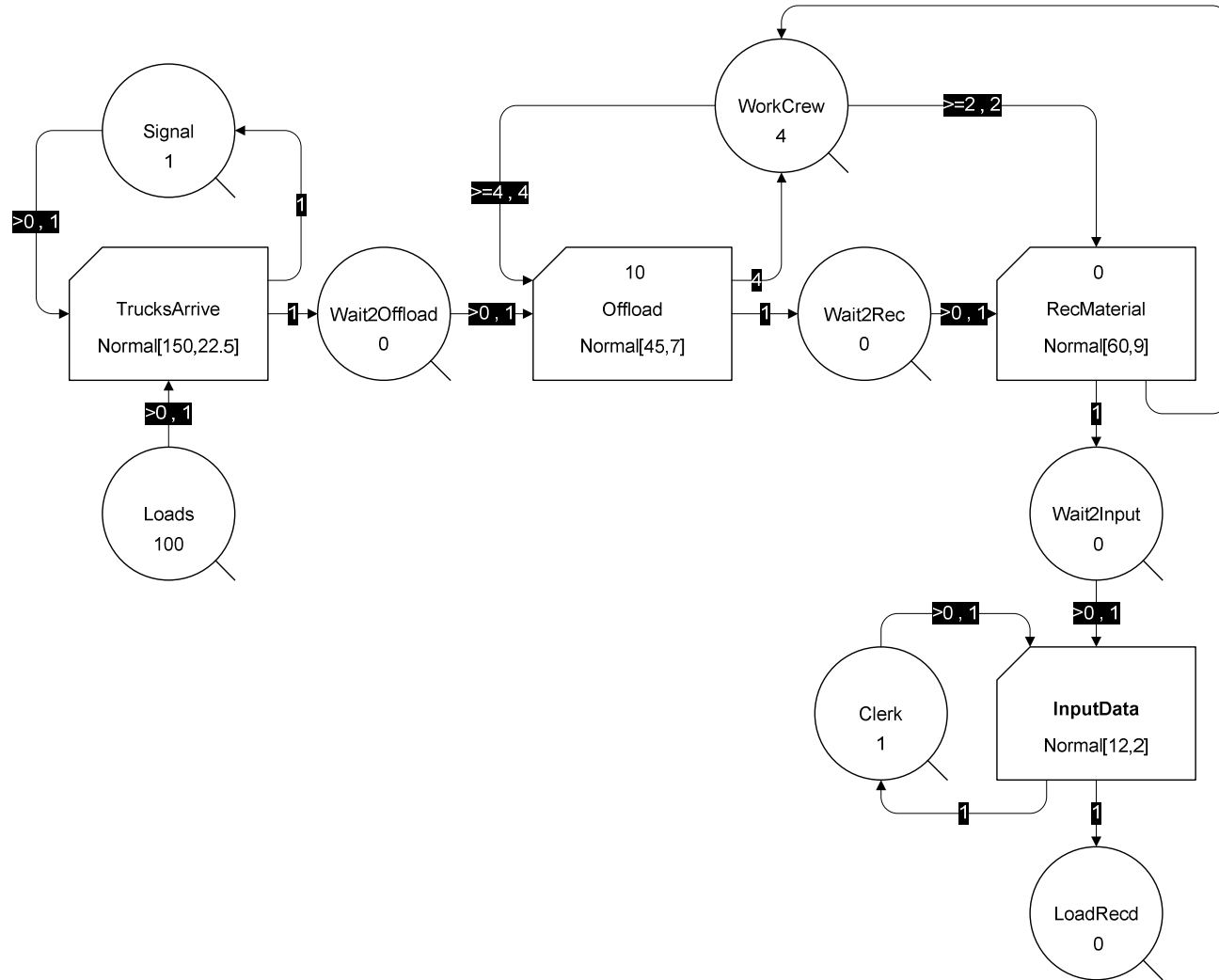

**Figure 3.5 – Existing Material Receiving Process**



### **3.4.2 Modified Material Receiving Process 1: Fixed RFID Readers**

The use of AMLTT, particularly RFID, has seen substantial success in the retail industry by improving the efficiency in which merchandise is received by the retailer (e.g. Wal-Mart) from the manufacturer at distribution warehouses (Hedgepeth, 2007; Lehpamer, 2008). This task is commonly completed by the use of fixed RFID readers mounted on the frames of shipping docks in which pallets of material must pass through when unloaded from containers or trailers. The pallets of goods or the individual items themselves are affixed with an RFID transponder. As the pallet is transferred from the shipping container, the reader registers the signal of the RFID tags and transmits the data back to the inventory management system. The system then registers the presence of the material in the warehouse. This same approach to automated material receiving using RFID can readily be applied to construction warehouse and laydown yard operations.

The existing material process model presented in Section 3.4.1 was altered in this instance to incorporate the use of fixed RFID readers. For this model it is assumed that all of the pipe spools being delivered to the site have already been tagged with RFID transponders at an earlier stage in the supply network (i.e. during fabrication). When a truck loaded with these ‘intelligent’ pipe spools arrives at the laydown yard it must pass through a gate (aka portal) to which is attached a series of RFID readers. As the truck, at a relatively low speed of travel ( $\pm 1$  m/s), passes through the gate the readers are able to interrogate the RFID tags attached to the items of interest. The overall concept is illustrated in Figure 3.6. After the truck has completely passed through the gate, it proceeds to be offloaded by a laydown yard crew. The received RFID data is subsequently uploaded to the MMS either automatically or by the support staff responsible for controlling access to the laydown yard.

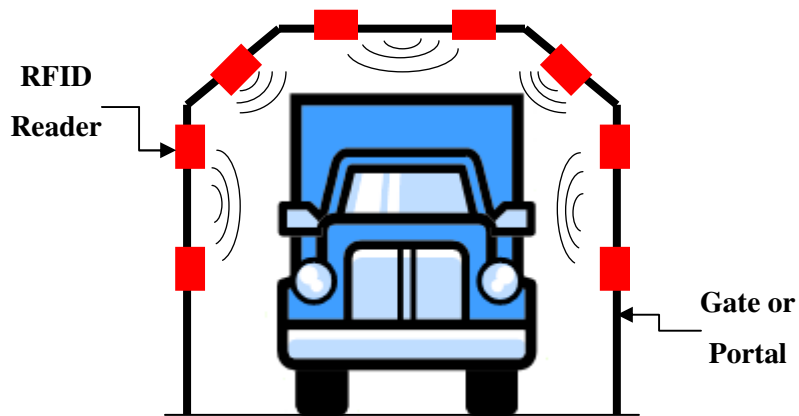

**Figure 3.6 – Truck passing through laydown yard gate with fixed RFID readers**

In general, the process described above differs in a number of ways from the existing process previously described. Receiving of material delivered to the site, in this case pipe spools, is completed entirely before the material has been offloaded and requires no direct human contact. Uploading of data to the MMS is also primarily an automated task. A simplified model of the process incorporating fixed RFID readers is presented in Figure 3.7. The modified EZStrobe model is depicted in Figure 3.8. The modifications made to the model are described below.

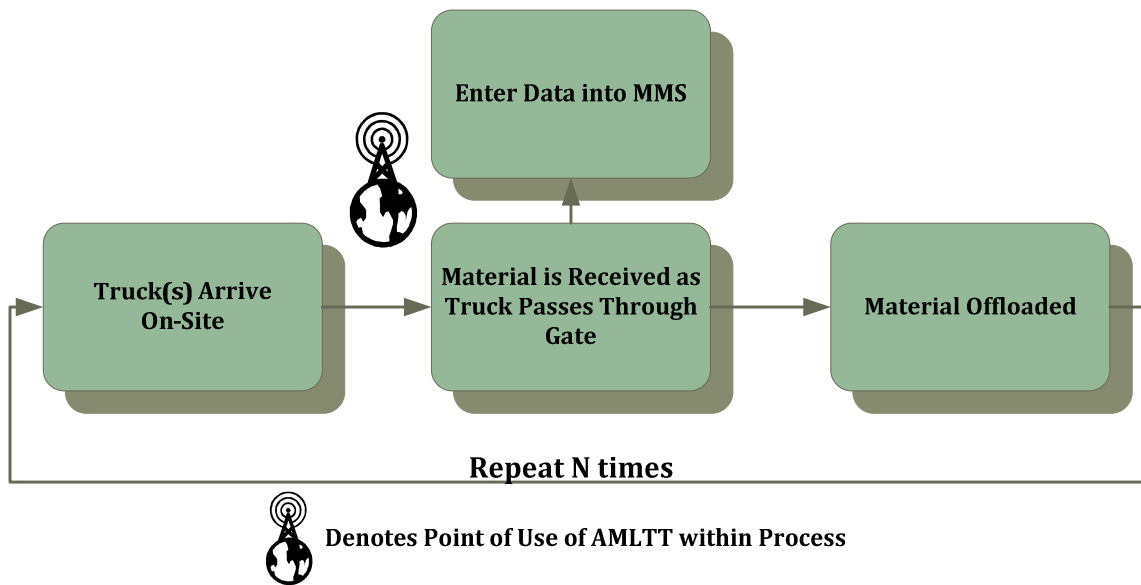

**Figure 3.7 – Simplified Modified Material Receiving Process 1: Fixed RFID Readers**

### 3.4.2.1 Modifications Incorporated into EZStrobe Model

The same principal task of receiving and unloading a series of pipe spools was again considered in this model. The rate of arrival of trucks and the unloading activity previously outlined in sections 3.4.1.1 and 3.4.1.2 remain unchanged. The incorporation of AMLTT is not considered to have any impact on these activities as part of this model. Only the order within the overall process in which receiving of material is completed and how it is theoretically accomplished were altered.

The *MaterialRecd* combi activity denotes the action of receiving material in the modified model shown in Figure 3.8. For this activity to be enacted a load must be present in the *Wait2Rec* queue and the controller must be available. The controller, symbolized by the *Controller* queue, is assumed to be responsible for uploading the data recorded from the passage of the truck through the entrance gate. In this case only one load at a time can be received. Hypothetically, it would be possible for multiple loads to be received at once if multiple gates were constructed. The duration for a load to be received is based on the

research conducted by Song et al (2006). In their investigation into the feasibility of using RFID to automate the task of receiving material, specifically pipe spools, on construction projects, the researchers utilized a fixed RFID system such as being described here. Song et al (2006) reported that a 99% read rate of the RFID transponders could be achieved if the truck passed through the gate at approximately 1 mph (0.45 m/s). For a standard tractor trailer of approximately 60 ft (18.3m) in length, it takes approximately 10 seconds for it to completely pass through the gate at the specified speed. To take into account factors such as relying instructions to the driver and verifying documentation, the total duration of the activity was increased to a conservative 5 minutes. A Normal distribution with a mean of 5 minutes and a standard deviation of 0.75 minutes was used to simulate possible randomness in the activity.

Uploading of data into the MMS is completed by the *DataUpload* combi activity. This activity also relies on the availability of the controller. As would be expected the controller gives priority to trucks arriving at the gate. A duration of 2 minutes was assumed for this activity. Variability was accounted for by employing a Normal distribution of mean 2 minutes and standard deviation of 0.25 minutes.



### **3.4.3 Modified Material Receiving Process 2: Mobile RFID Readers**

Another approach to incorporating AMLTT in the material receiving process is through the use of mobile RFID readers, such as depicted in Figure 2.5. This approach to receiving material and monitoring items is very similar to the current use of mobile barcode readers employed by courier services and warehouse operations. Instead of having to manually check material identification numbers against a shipping manifesto, this task is completed automatically. Warnings or errors are displayed on the handheld device in the event of a discrepancy, allowing for the user to take immediate action. Unlike a mobile barcode reader, however, a mobile RFID reader makes use of all of the advantages previously outlined in Section 2.3.1.2. The added advantage of utilizing mobile readers is the incorporation of location algorithms based on GPS technology, which not only allows for a particular item to be received into the MMS, but also the ability to fix its current location within the warehouse or laydown yard.

The use of mobile readers was incorporated into the existing material receiving process based on the past experience of the author using this technology during the PEC field trial. As was the case in the previous modified process model, it is again assumed for this model that each of the pipe spools delivered to the site have already been tagged with RFID transponders. The actual task of receiving material is shifted back to its original position within the overall process: after the unloading stage. This was done to account for safety concerns that might arise due to warehouse support personnel interfering with lifting operations or the inherent risk of falling from a flatbed trailer loaded with material. Instead of having to manually identify each item delivered in a load, the support personnel simply need to walk amongst the offloaded material with their RFID reader set to receive and record transponder signals. The photo in Figure 3.9 depicts a worker (i.e. UW graduate student) utilizing a mobile RFID reader in a laydown yard at PEC.



**Figure 3.9 – Worker using a mobile RFID reader in a construction laydown yard**

When the worker is satisfied that they have collected at least one ‘read’ from each of the transponders they can proceed to upload the assembled data into the MMS. Depending on the layout of the site, uploading of this data may be possible via wireless network or may require the worker to travel to a wired computer station. Alternatively, if the worker is unsure whether they have collected ‘reads’ from each transponder in a particular set of loads, they can rescan the area of interest, prior to proceeding to upload the assembled read data. A simplified model of the material receiving process incorporating mobile readers is shown in Figure 3.10. The modified EZStrobe model is shown in Figure 3.11 and a description of the changes included in the model follows.

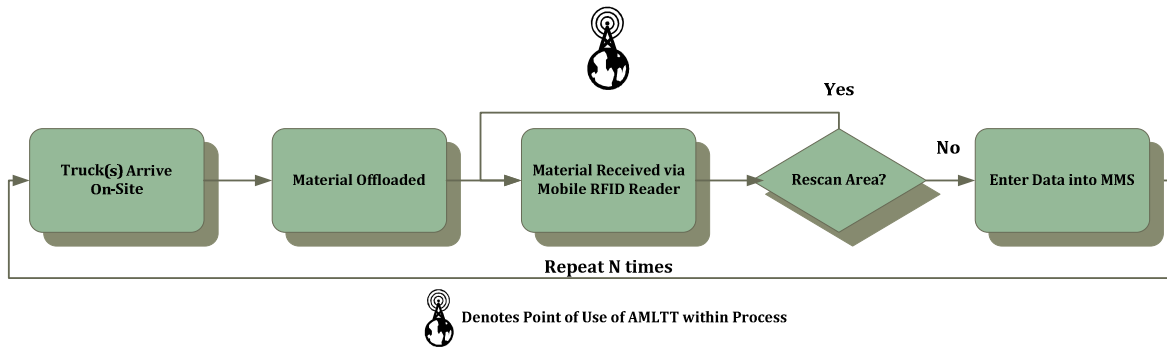

**Figure 3.10 – Simplified Modified Material Receiving Process 2: Mobile Readers**

### 3.4.3.1 Modifications Incorporated into EZStrobe Model

The arrival rate of trucks and the offloading activity again remain unchanged in the EZStrobe model incorporating mobile RFID readers. In this model the task of receiving material is completed by the *RecMaterial* combi activity. Instead of utilizing members of the work crew to perform this ‘soft’ task, the clerk, who is assumed to be someone familiar with the technology and its operation, is employed. The clerk is controlled by the *Clerk* queue. It was assumed for simplicity, that the clerk would process one load at a time. However, in practice it might be expected that the clerk would wait until multiple loads had been delivered before proceeding to the laydown yard to collect the necessary data. An average duration of 5 minutes per load was selected for this activity based on the author’s own experience in completing similar tasks at PEC. A Normal distribution of mean 5 minutes and standard deviation of 0.75 minutes was applied to account for randomness in the activity.

When the model has completed the receiving process, it then instruments a probabilistic based decision to account for the instances when the clerk will need to re-scan the previous loads. The probability that a series of loads will need to be scanned was assumed to be 5%. This assumption is again based on past experience. The *ReScan* normal activity processes the re-scan activity. The duration for this activity is based on that assumed for the material receiving activity. It was scaled down from 20 minutes to 15 minutes to account for the worker being more familiar with the arrangement of the items within the laydown yard. A Normal distribution with a mean of 15 minutes and a standard deviation of 2.25 minutes was employed in this case.

Once the location data has been collected the model progresses to the point of entering the recorded data into the MMS, which is managed by the *InputData* activity element. The duration of this activity is modeled using a Normal distribution with a mean of 5 minutes and standard deviation of 0.75 minutes.



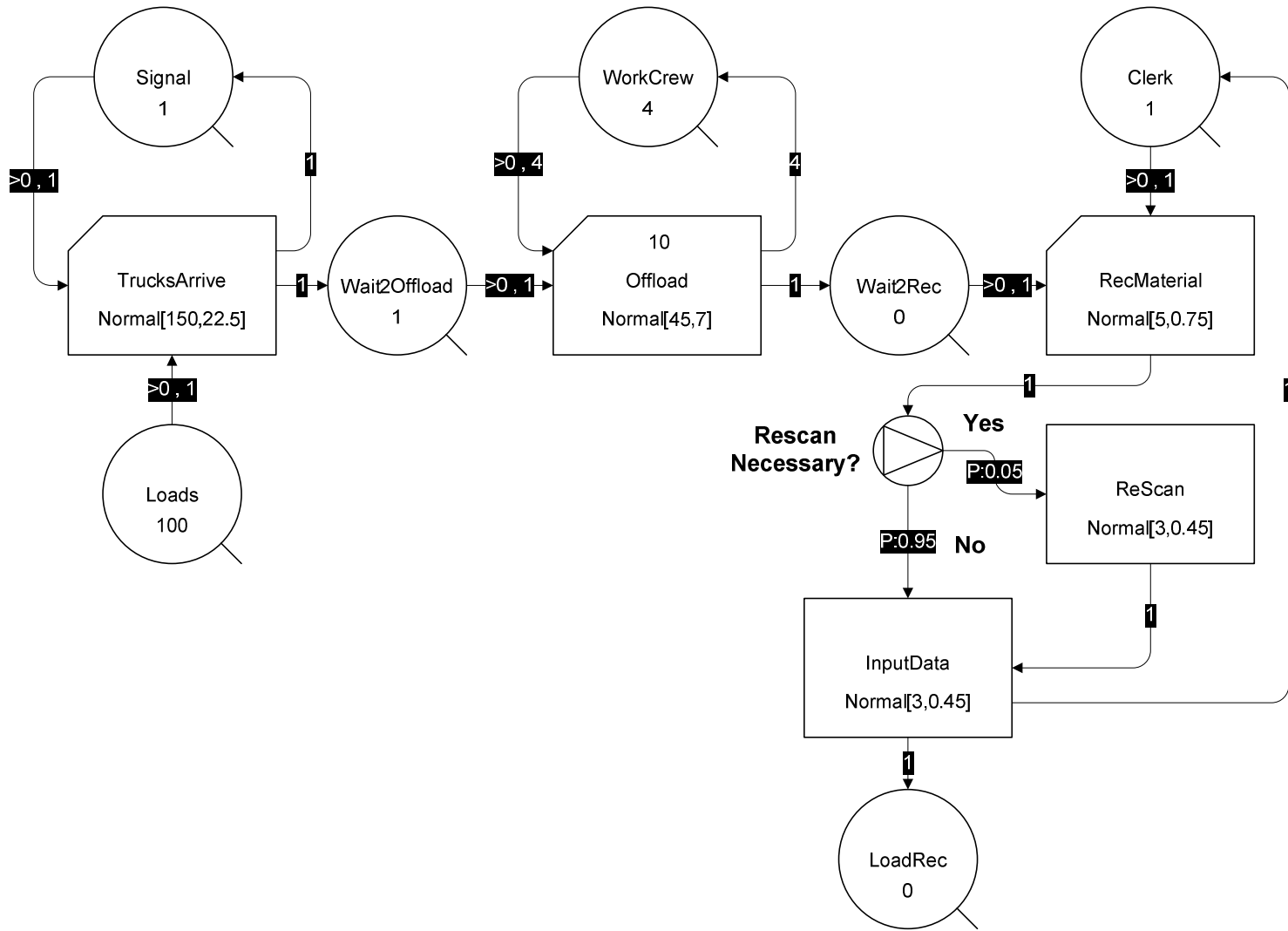
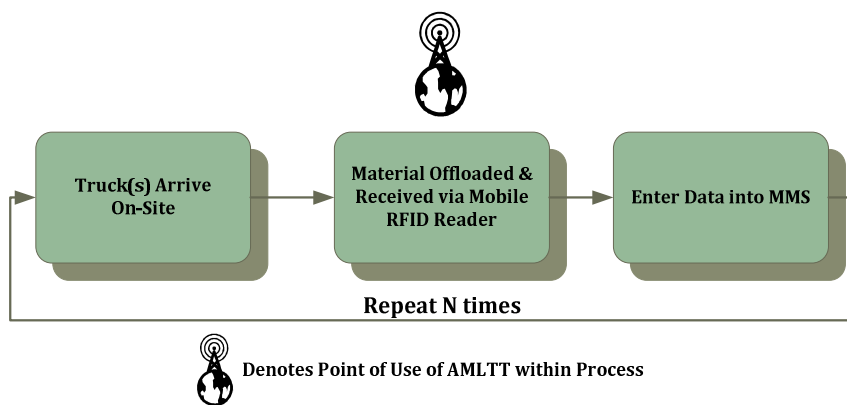

Figure 3.11 – Modified Material Receiving Process 2: Mobile Readers

### 3.4.4 Modified Material Receiving Process 3: Crew Based Mobile RFID Readers

An alternate approach to the model presented in Section 3.4.3 is to base the mobile RFID readers with the offloading crews. The RFID reader could be attached to the work belt of a member or members of the offloading crew like any other hand tool or cell phone. The simplified model incorporating this change is depicted in Figure 3.12. Following offloading a load of material, the crew member would either upload the assembled data to the MMS wirelessly or download it to the system via a wired computer station at a later point in time. The modified EZStrobe model is shown in Figure 3.13 and the modifications included are discussed below.



**Figure 3.12 – Simplified Modified Material Receiving Process 3: Crew Based Mobile Readers**

#### 3.4.4.1 Modifications Incorporated into EZStrobe Model

The use of crew based RFID readers to complete the material receiving process simplifies the model previously presented in Section 3.4.3. Again, it is assumed that the arrival rate of trucks is unaltered by the use of AMLTT and that the pipe spools arrive on site already tagged. In this case, the duration of the offloading activity, denoted by the *Offload* combi activity in Figure 3.13, was increased to account for the receiving action completed by at least one member of the crew. An additional 30 seconds per pipe spool was added to the

original offloading duration of 45 minutes. This resulted in a final activity duration of 55 minutes per load. Again, a Normal distribution was employed with a mean of 55 minutes and standard deviation of 8.25 minutes.

Once a load has been received and offloaded a signal is passed to the *UploadData* combi activity within the model. The same activity duration as employed for the previous model (N(5,0.75)) was used.

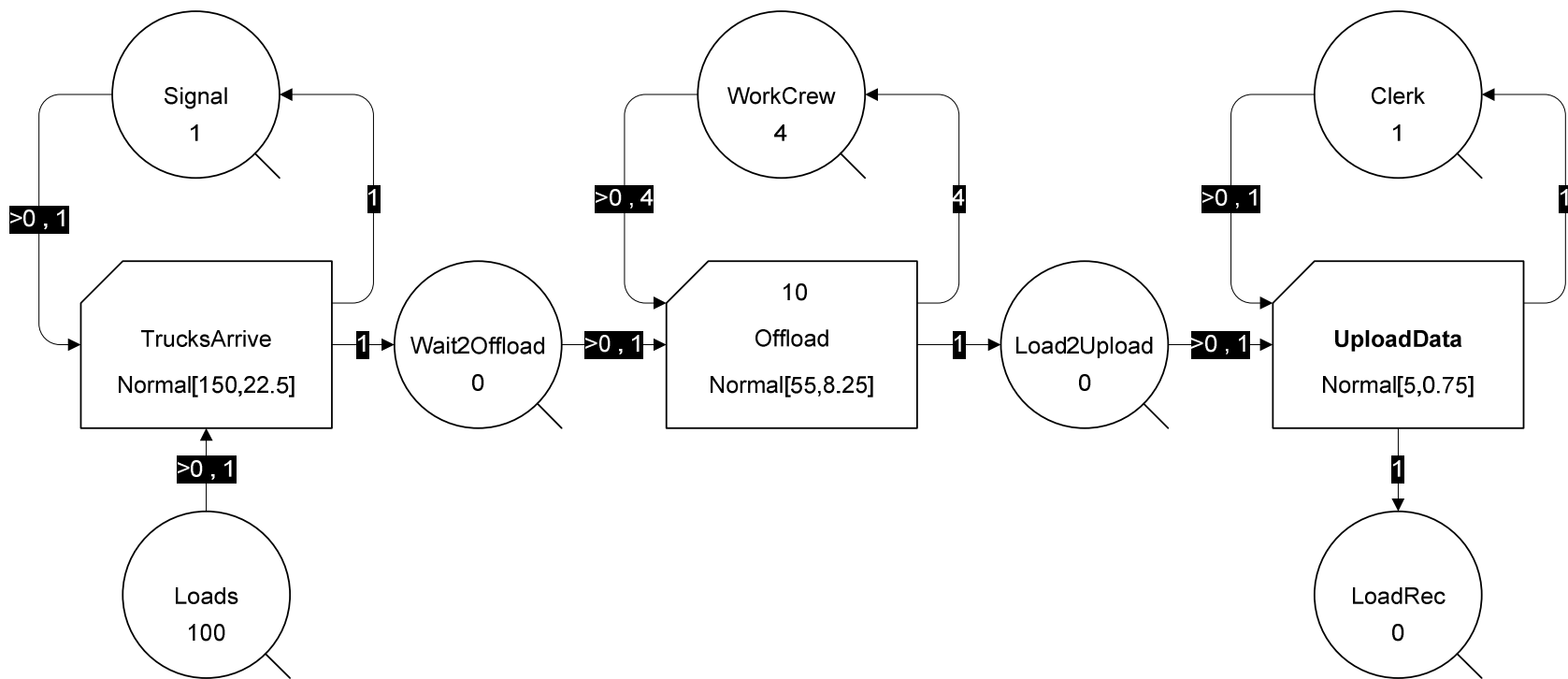
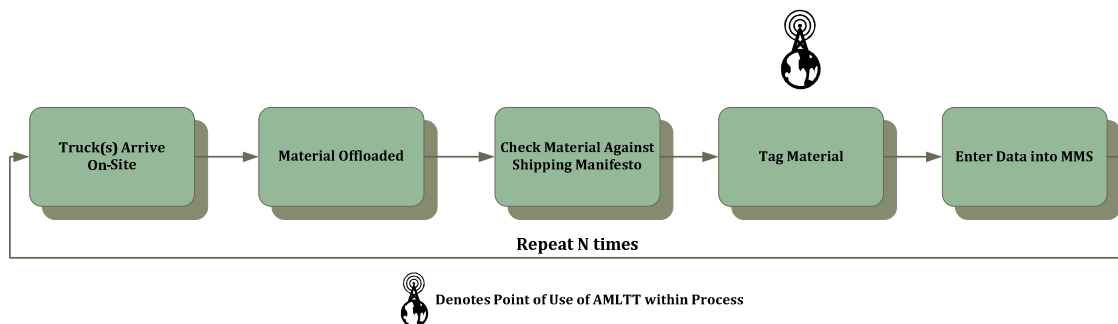

**Figure 3.13 – Modified Material Receiving Process 3: Crew Based Mobile Readers**

### 3.4.5 Modified Material Receiving Process 4: Untagged Material

The final modifications made to the material receiving process to integrate AMLTT were to present a means of accounting for materials which may arrive to the site untagged (without an RFID transponder attached). This will likely be the inevitable situation faced on many construction projects in the near future that are planning to implement AMLTT at the site level. Of course, if the owner or general contractor is able to leverage their purchasing power to enforce an RFID inclusion policy with their fabricators, this will not be an issue. Nonetheless, the modified process accounting for untagged material is presented here.

The simplest means to account for material received without a pre-existing RFID transponder is to attach one when they arrive on site. The overall receiving process becomes a combination of the existing manual approach and the mobile RFID reader approach. Once the untagged material has been unloaded, a crew member or other personnel will be required to identify each unique item, check it against the shipping manifesto, attach a transponder to the item, associate the transponders serial number with the items identification number, and finally enter all of this information into the MMS. The remainder of the process tasks (e.g. arrival rate, offloading, data input) remain unchanged. The simplified process model accounting for untagged material is presented in Figure 3.14. The complete EZStrobe model for this modified process is shown in Figure 3.15 and the modifications to it are described below.



**Figure 3.14 – Simplified Modified Material Receiving Process 4: Untagged Material**

### **3.4.5.1 Modifications Incorporated into EZStrobe Model**

The additional step of attaching an RFID transponder to each item was incorporated into the material receiving model. This step is accomplished in the model on the following page by the *TagMaterial* combi activity and is facilitated by the presence of an entity in the *Wait2Rec* and *Clerk* queue. A duration of 2.5 minutes to tag a pipe spool was used; this duration was selected based on the author's own experience at PEC. Thus, the time required to tag a complete load of 20 pipe spools is taken to be 50 minutes. A Normal distribution with a mean of 50 minutes and a standard deviation of 7.5 minutes was used in the model.

The actual task of receiving material also had to be modified in this model to account for the increased duration associated with referencing a specific transponder back to the item to which it is attached. Jaselskis and El-Misalami (2003) reported an average of 3.9 minutes per pipe support to complete a similar task in their study. Accordingly, a 4 minute duration per pipe spool was applied. The total activity duration is modeled using a Normal distribution with mean of 80 minutes and standard deviation of 12 minutes.

Once a load has been received a signal is passed to the *UploadData* activity within the model. The same activity duration as employed for the previous models was again used here.

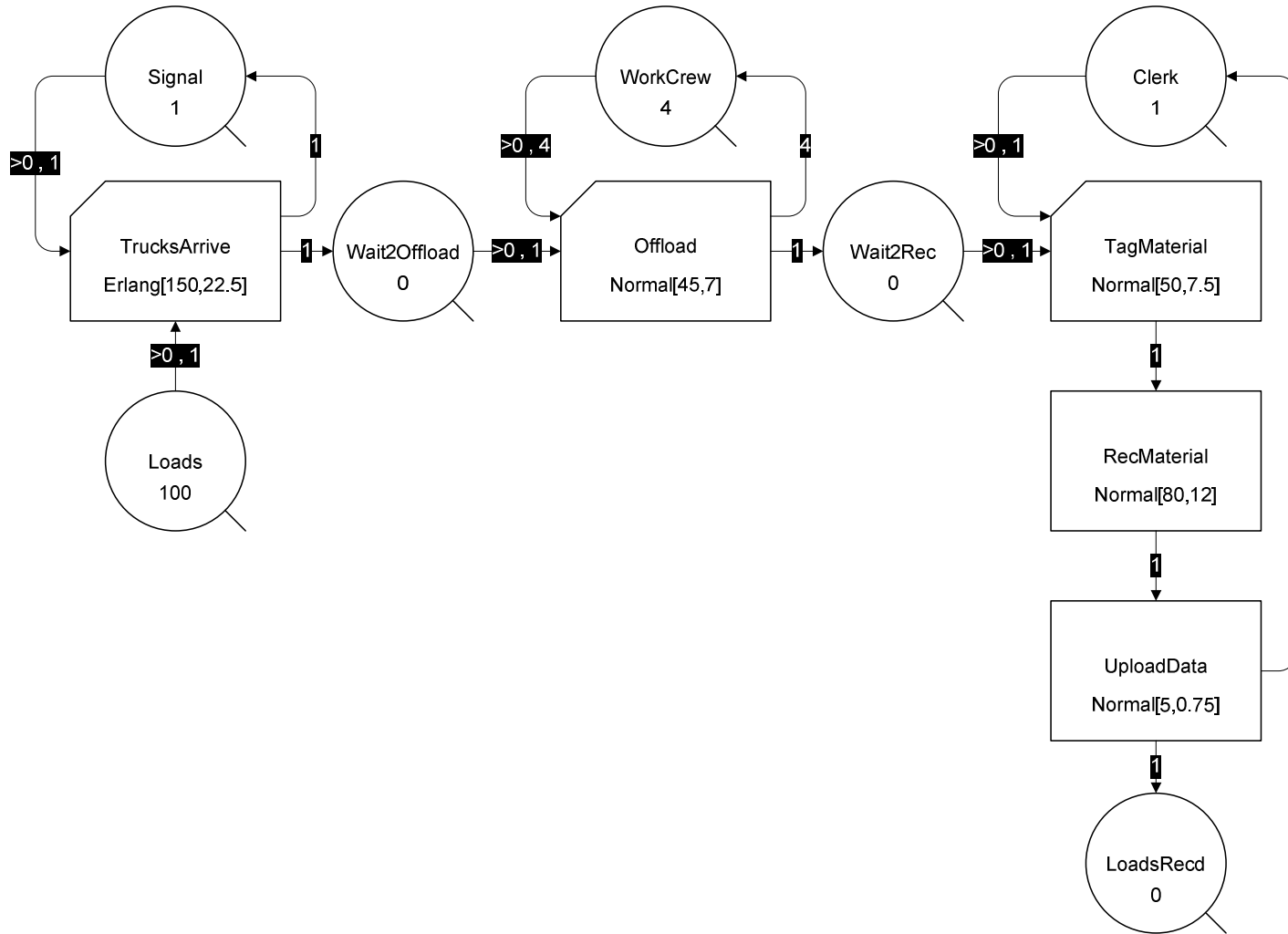

Figure 3.15 – Modified Material Receiving Process 4: Untagged Material

### **3.5 Locating Material in a Construction Laydown Yard**

The prompt identification and retrieval of material from a laydown yard is an important factor in maintaining the desired rate of production at the construction work face. Research has shown that a positive impact on crew performance and productivity can be achieved if work crews can be provided with accurate information regarding the status (i.e. location, availability, delivery time) of the materials they require (Song, Haas, & Caldas, 2006). As a result, there is a great deal of pressure on warehouse workers to locate specific material items in laydown yards, often measured in the 1000's of square meters, or within warehouses in a timely manner. The efficiency in which this task is carried out is directly connected to the accuracy of the location recorded for a particular item. If the location record for a particular item is out of date or simply inaccurate, the warehouse crew will potentially waste hours or even days searching for the item to no end. The worst case scenario is that an unfound item is declared lost and a replacement must be ordered. This not only leaves work crews left waiting idle until the material is found or other tasks are assigned, but can also have potentially serious impacts on the entire project.

#### **3.5.1 Existing Process Model**

The model developed to represent the existing process of locating items within a construction laydown yard is structured around the general procedure followed by the warehouse personnel at PEC and Rockdale. This procedure, which is outlined in Figure 3.16, is composed of five different steps. First, a subcontractor must make a request for an item or items to be released from the laydown yard. This step usually involves filling out one or more forms that are kept on record in the event a dispute arises pertaining to the issuance of material. Next, the request for material must be approved. Upon approval of the request, the warehouse personnel are dispatched to locate the required items within the laydown yard or warehouse. In the case of the Rockdale field trial, flags were placed beside each item



located, facilitating their retrieval by craft workers. The layout of the laydown yards and warehouse at PEC did not facilitate a similar marking system (Construction Industry Institute, 2008). Once the requested materials were located and retrieved, they are transferred to the subcontractor, who assumes responsibility for them.

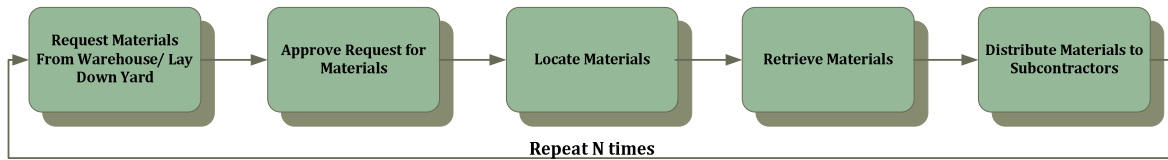

**Figure 3.16 – Simplified Existing Material Locating Process**

In the event that a particular item cannot be directly located within the laydown yard or warehouse, a search for it must be undertaken. The search will likely involve a review of records to ensure that the item has actually been received or has not already been issued. The search will also involve personnel being dispatched to the laydown yard to manually look for the item in question. Figure 3.17 depicts the incorporation the search activity into the model logic previously presented.

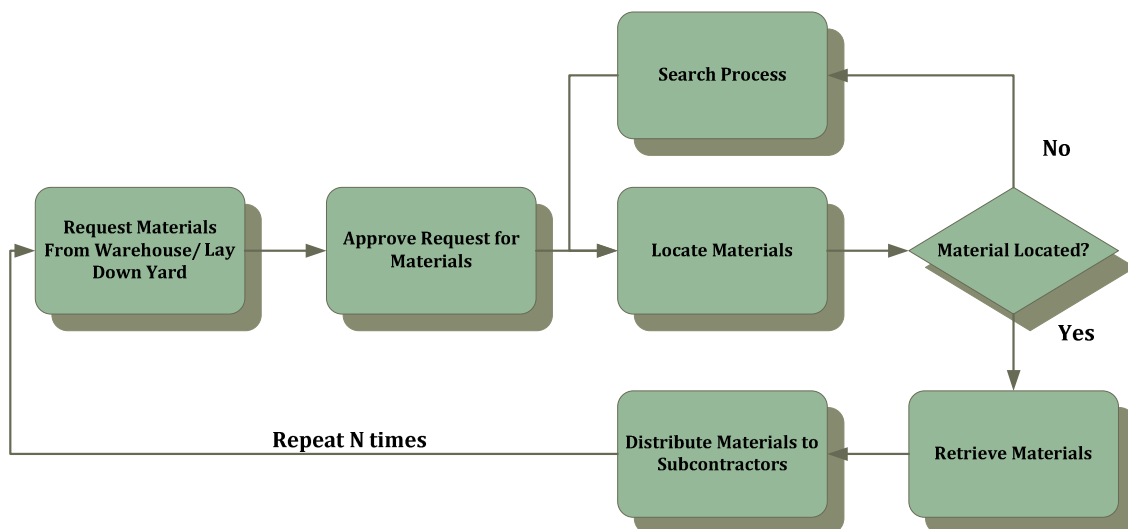

**Figure 3.17 – Incorporating Possible Search for Lost Material in Existing Process**

The focus of the formulated EZStrobe model, depicted in Figure 3.18, is not simply on recreating a representation of the material locating process, as described above. Instead its primary purpose is to investigate the impact that prolonged searches for lost material can have on a project in terms of delay and cost. The underlying theory is that there is a relative possibility that for every item not immediately located within either a laydown yard or warehouse that it will ultimately be declared lost; this in turn requires a replacement to be ordered. At the same time, however, there is the possibility that a potentially lost item will be located during one of the preceding searches performed on site. The end result of each search carried out (i.e. was the item found?) has a varying impact on project efficiency, depending on the level of importance of the item being sought. For example, if an item, which has a long-lead time and is critical to the progress of construction, happens to fall within the threshold of ‘ultimately lost’, the impacts on the project are enormous. The impact on the project, however, is mitigated if that item was able to be located on site, even after a prolonged search. This theory is explored using the constructed model.

The overall frame of reference for the model is an arbitrary industrial project that operates a controlled laydown yard and warehouse, as was observed during the Rockdale and PEC field trials. Over the course of the project duration a significant number of individual requests for material are made. It is assumed that these requests are being made for items either known or believed to be located within the laydown yard or warehouse. It is also assumed that a completely manual search process is employed as part of the existing process model (i.e. AMLTT is not used). The structure of each stage of the model is discussed below.

#### **3.5.1.1 Requests for Material Release**

Over the course of the construction of an industrial construction project a significant number of requests for material locates could be expected. As such, 10,000 separate requests for the

release of material from the theoretical project laydown yard and warehouse are simulated by the model (see Figure 3.18). Similar to the models presented in Section 3.4, a request in this case could be considered to be for one single item or for a group of like items. A project duration of 400 working days was also chosen.

The rate at which requests are generated within the model is controlled by the *Request4Item* combi activity. The rate of requests was considered to be highly variable, due to the likelihood of occurrence of bursts of requests within a short period of time (i.e. at the beginning of a shift), followed by periods in which very few requests are made. As such, a triangular distribution, with a mode of 24 minutes, minimum of 1 minute, and maximum of 60 minutes was used to model the duration of the noted activity element. Based on the selected project duration, 25 requests per 10-hour day are expected to be processed by the model.

### **3.5.1.2 Approval of Material Requests**

The approval of requests for the release of material is symbolized by the *ApproveRequest* combi activity. For simplicity, it is assumed that each request is approved. Also, only 1 request is processed at a time. A Normal distribution of mean 5 minutes and standard deviation of 0.75 minutes was assumed for this activity.

### **3.5.1.3 Retrieval of Requested Material**

Once the request has been approved, a member of the warehouse crew is tasked with retrieving the required material from the laydown yard. This task is managed by the *ItemRetrieval* combi activity in the model. For this activity to be initiated a request for the retrieval of an item must be present in the *Wait2Retrieve* queue and a member of the warehouse crew, represented by the *WorkCrew* queue, must also be available. A 4 person warehouse crew, similar to the previous models, was chosen. Based on the results of the Rockdale field trial presented in Torrent & Caldas (2007) and CII (2008), the average

duration to locate an item (untagged) within the Rockdale laydown yard was recorded to be 8.2 minutes. Thus, the associated activity duration was modeled using a Normal distribution, with a mean of 8.2 minutes and a standard deviation of 1.2 minutes.

#### **3.5.1.4 Search Process**

The possibility that an item will not be located following the completion of the initial retrieval process is modeled using a series of stepped decision forks (See Figure 3.18). Torrent & Caldas (2007) reported that approximately 9.5% of the items (untagged) within the scope of their study were not initially found using a manual search process. Subsequently, a 10% probability that an item will not be located after the initial locate activity is completed was applied to the model at the first decision level of the search process. If an item is considered to be located within the model, a signal is sent to the *ItemDelv1* combi activity and the warehouse personnel returns to its idle state. A similar delivery process is used in the subsequent phases of the search process described below.

If an item is not found within the first decision level of the model, it progresses to the second phase of the search process. This phase is controlled by the *ManualSearch2* normal activity. This activity represents a more detailed search of the vicinity of the laydown yard where the item was expected to be located. A triangular activity duration with a mode of 30 minutes, minimum of 10 minutes, and maximum of 240 minutes was applied to this phase of the search process. A 15% probability that the item will continue to remain 'lost' was applied at this decision level. The corresponding probability is based on correspondence with members of RT-240 who expected the likelihood for an item to remain unfound to increase after subsequent phases of the search process were completed (Carl Haas, personal communication, February 13, 2009).

The third and final phase of the search process, represented in the model by the *ManualSearch3* normal activity, corresponds to an intensive, potentially multi-day, site wide,

search for the item in question. A triangular activity duration with a mode of 240 minutes, minimum of 60 minutes, and maximum of 1200 minutes (20 hours or 2 full working days) was used. A 33% probability that an item will remain unfound after this phase of the search process was applied. Overall, the product of this probability branch and that of phase two, results in 5% of the total initially unfound items being declared completely lost. The selection of this final probability outcome is also based on correspondence with members of RT-240 (Carl Haas, personal communication, February 13, 2009).

Once an item is considered to be lost, a replacement must be reordered. This step in the model is accomplished by the *Reorder* normal activity. A Normal distribution with an average of 240 minutes and standard deviation of 36 minutes was used to model the processing time of this activity. Once the item has been reordered a period of time must pass before the replacement item is delivered to the site. The waiting period was modeled using a triangular distribution with a mode of 2400 minutes (4 working days), minimum of 600 minutes (1 working day), and maximum of 6000 minutes (100 working days). At this point, it is assumed that the replacement item does not re-enter the laydown yard or warehouse system, but is instead delivered directly to the construction work face.

### **3.5.2 Modified Material Locating Process**

The integration of AMLTT, in this case both RFID and GPS, into the material locating process on construction projects has had substantial success at the field trial level as described in sections 2.3.3 and 3.2. If used effectively, AMLLT has the potential to increase the accuracy and rate of capture of material location information for laydown yard and warehouse operations on a scale that was previously not attainable. Existing operations, such as employed at Rockdale and PEC, rely on manually updated location records. It is therefore infeasible and not practical from a labour allocation standpoint to consider updating the entire database of material locations on a regular basis or even at all. On the other hand, an

AMLTT based system could completely update the record of each material affixed with a working RFID transponder in a laydown yard within a matter of hours or less. In turn, it could be expected that an increased level of awareness of the location of the material stored in a laydown yard or warehouse would potentially result in a decrease in the number of items declared unfound. The modifications made to the existing material locating model were made to investigate this theory. The modified EZStrobe Model is shown in Figure 3.19.

### **3.5.2.1 Modifications Incorporated into EZStrobe Model**

The overall structure of the modified EZStrobe model is essentially the same as the existing process model previously described. In this case, however, it is assumed that each of the items stored within the laydown yard or warehouse have been affixed with an RFID transponder. The rate at which requests for material are submitted and approvals made remains unchanged in this model. The same assignment of an individual member of the work crew to each item retrieval request and the process in which found items are handled within the model also remain unchanged. The primary changes to the model are in regards to the item retrieval activity and the overall search process.

The *ItemRetrieval* combi activity is responsible for completing the initial material locate stage in the modified model. Torrent & Caldas (2007) reported that an average of 2.9 minutes was required to retrieve a tagged item from the laydown yard at Rockdale. The same approximate time requirement was employed in the model. In this instance, the *ItemRetrieval* activity duration was modeled using a Normal distribution with a mean of 2.9 minutes and a standard deviation of 0.44 minutes.

The search process for potentially lost items was expanded in the modified model to incorporate the use of AMLTT. It is assumed that the warehouse personnel are operating mobile RFID devices capable of synchronizing its GPS location and that of a transponder (it is also not unforeseeable in the near future that similar devices will be able to incorporate a

homing function). A 1% probability that an item will not be initially located by the warehouse staff was used in the model. Torrent & Caldas (2007) reported a similar expected level of unlocated tagged items.

The second phase of the search process in the modified model is symbolized by the *ReScanSmArea* normal activity. This activity represents the completion of a rescan of the surrounding area in which the item was expected to be located based on its most current location recorded. A triangular distribution with a mode of 10 minutes, minimum of 5 minutes, and maximum of 20 minutes was assigned to the duration of this activity. In the event that the item remains unfound the third phase of the search process begins. A 10% probability of reaching the third phase was also assigned.

The third phase of the search process is represented by the *ReScanLgArea* normal activity element. This element accounts for a rescan of the entire laydown yard or warehouse. A triangular distributed activity duration with a mode 30 minutes, minimum of 15 minutes, and maximum of 60 minutes was assigned to this phase. There is a 15% probability that the item will remain unfound after this phase and the model will progress to the fourth phase of the search process.

The fourth stage, symbolized by the *ReScanProject* normal activity element, as its name implies, accounts for a rescan of the entire project site. A triangular distributed activity duration with a mode 120 minutes, minimum of 60 minutes, and maximum of 240 minutes was assigned to this phase. A 20% probability that the model will progress to the fifth phase of the search process was assigned to this decision level.

The fifth phase of the search process is depicted by the *ManualSearch* normal activity element and represents the last step taken before an item is considered lost. A triangular distributed activity duration with a mode 240 minutes, minimum of 60 minutes, and

maximum of 1200 minutes was assigned to this phase. The probability of not locating the item in question after completing the manual search was assigned to be 25%.

The *Reorder* normal activity and the *Wait4Reorder* combi activity elements processes any items within the model that have been deemed to be lost. No changes were made to the durations associated with these activities. Overall, based on the probabilities outlined above, it would be expected that 7.5% of the initial 1% of the items not initially found will eventually be declared lost.



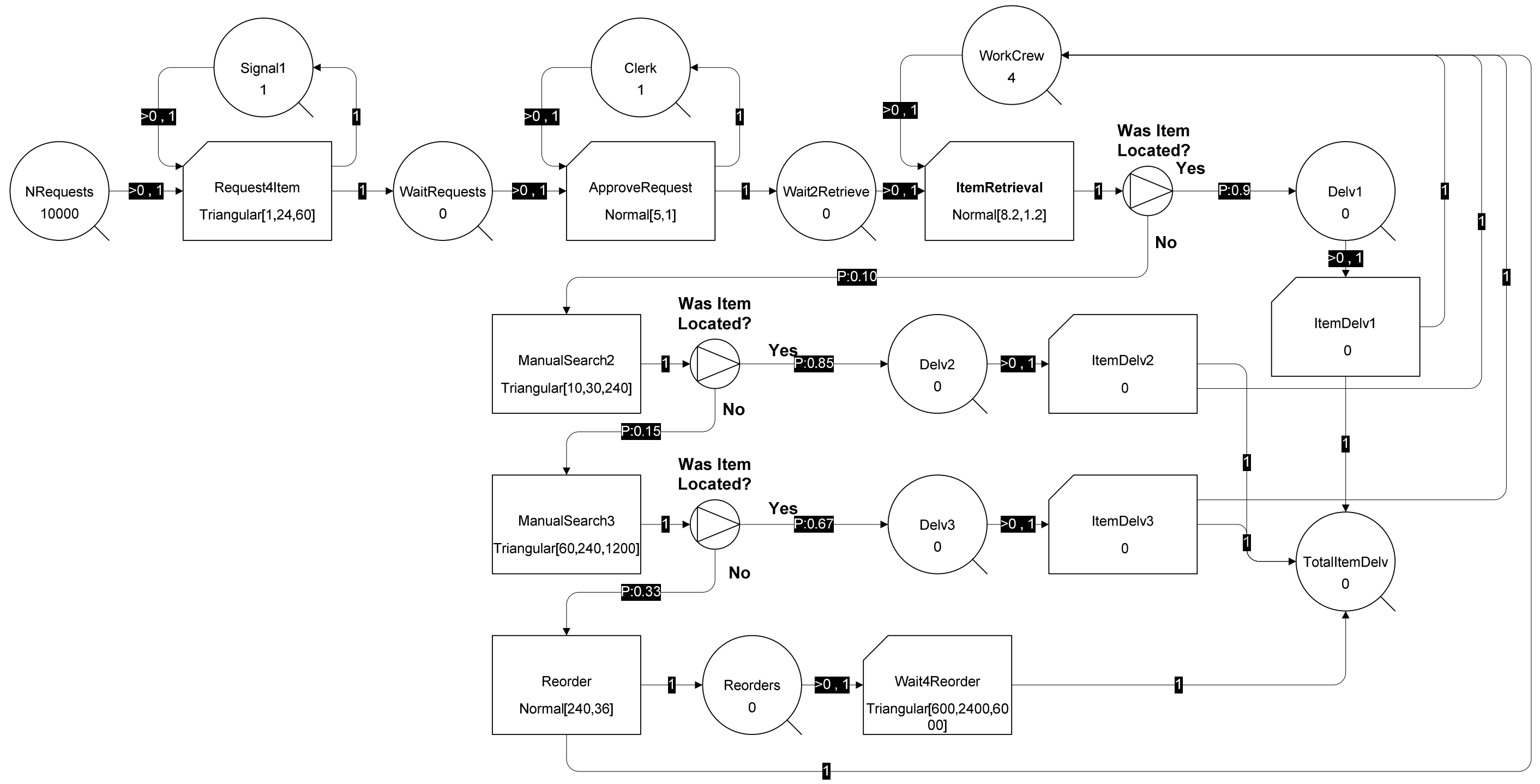

Figure 3.18 – Existing Material Locating Process Model

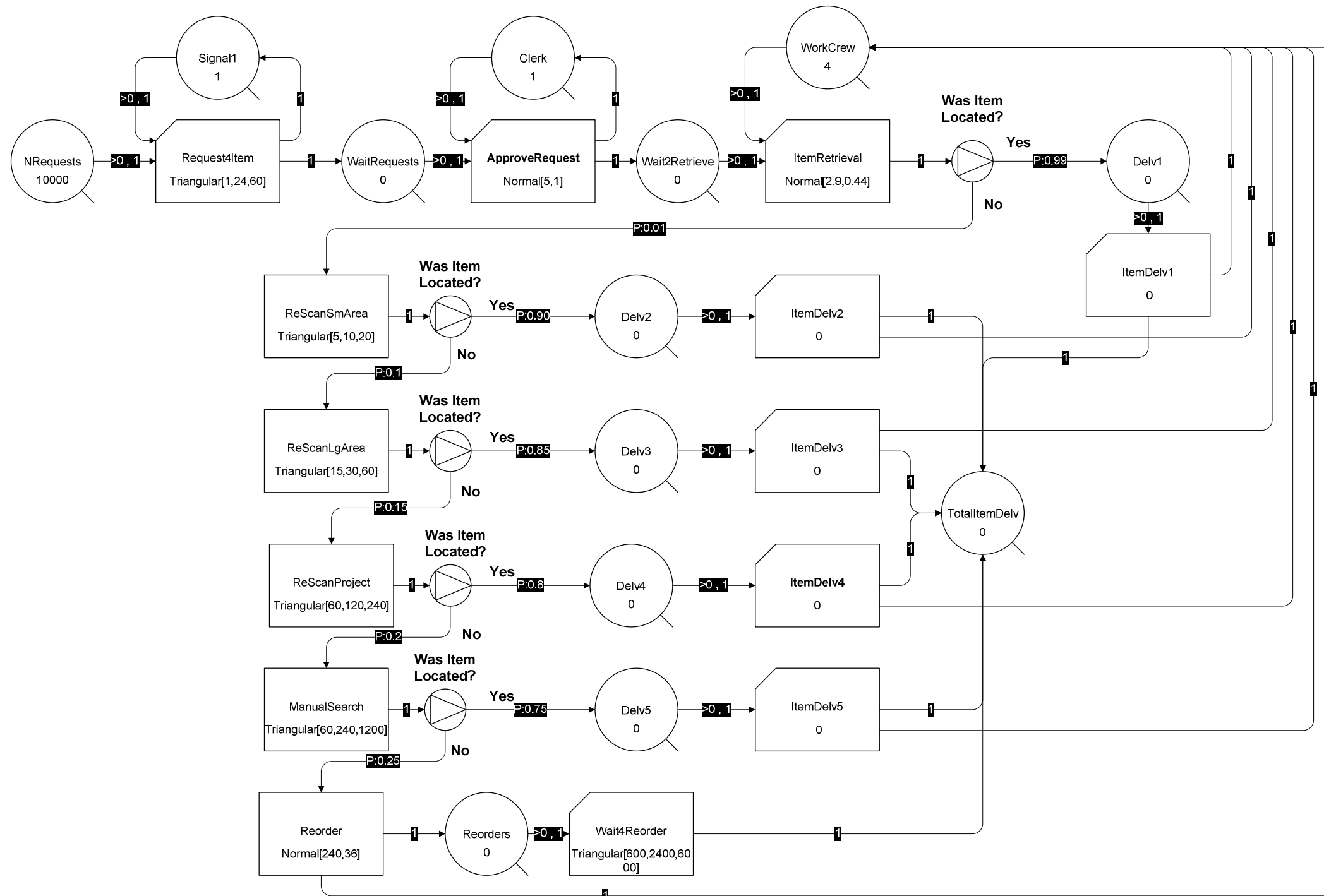

Figure 3.19 – Modified Material Locating Process Model

### **3.6 Increasing Visibility within the Construction Supply Network**

Large scale construction projects are plagued with uncertainties ranging from uncertainty in the occurrence of an extreme weather event (e.g. hurricane or ice storm) to labour unrest. Many of these uncertainties, however, revolve around whether the materials and equipment required to ensure the continual progress at the construction work face will be available on schedule. One means of mitigating the uncertainty in the delivery of material is to build up a stockpile of all of the required items before beginning construction of the facility. This practice is not only costly in terms of upfront capital cost, but also in terms of time as project durations are significantly extended to account for long lead items. Nonetheless, the practice of accumulating a percentage of the material required to complete a specific series of tasks (i.e. piping) in a stockpile (aka buffer) prior to beginning installation is common place on most large construction projects, especially industrial facilities (Howell & Ballard, 1996). Why else would there be a need for laydown yards that are measured in terms of football fields? The necessity for material buffers has much to do with project managers on site having an overall lack of information about the status of material and equipment at different stages of the construction supply network. In other words, they lack visibility of the on goings within the supply network.

Supply network visibility is a critical component of supply network operations and one of the drivers behind supply network management (Delen, Hardgrave, & Sharda, 2007). In essence, supply network visibility is the degree to which a constituent of a supply network has knowledge of the state of the services or goods it is being provided with by its suppliers. Increased supply network visibility corresponds to an increased level of awareness brought on by the transfer of information from one trading partner to another down the supply network (Delen, Hardgrave, & Sharda, 2007). The concept of supply network visibility is analogous to the case of the public transit user who relies on various forms of information to

ascertain the time of arrival of their chosen means of transportation. A more comprehensive means of information transfer (i.e. posted arrival times vs. arrival times updated in real time) has the potential to increase a rider's level of awareness of when the next pickup will occur. In construction operations it is often the inability or unwillingness to convey accurate and detailed information in a timely manner regarding the state of production which results in a lack of supply network visibility and consequently reinforces uncertainty in the timely supply of material and equipment (Howell & Ballard, 1996).

Information sharing is spread across all levels of the construction supply network including engineering and design, fabrication and supply, and construction management (Howell & Ballard, 1996). Architects and engineers are responsible for conveying the facility concept and design requirements to material and equipment fabricators in a readily readable form (e.g. 2D drawings, 3D CAD models, BIM). Fabricators must take this information and transform it into actual material goods. The construction manager is responsible for establishing the material delivery schedule that facilitates the most efficient installation process on site (Howell & Ballard, 1996). Each interface within the supply network described above requires one constituent to transfer information critical to the progress of the next supply network constituent. If the information provided to a constituent is either lacking in sufficient details (e.g. specifications) or not forthcoming at all, uncertainty arises as to whether the constituent will be able to fulfill its obligations to those it supplies to. Over time, this uncertainty has resulted in anticipatory measures being taken by those constituents further down the supply chain in an effort to mitigate the potential impact on their own operations. In the construction industry this is manifested in the form of large material stockpiles stored in laydown yards and warehouses.

The series of models presented in this section were used to investigate the premise that an increased level of information transfer within the construction supply network, regarding the

status of material and equipment, would subsequently reduce uncertainty at the site level. As a result, potential work opportunities would be created and taken advantage of.

For this thesis, a work opportunity is defined as a task or series of tasks that could potentially be started and completed earlier in the construction schedule. These work tasks, however, are typically delayed due to uncertainty in the ability of the supply network to provide sufficient and/ or the required material to allow for an adequate and constant rate of production to be attained on site (i.e. the risk of delay is considered too great). Consequently, these work tasks are put on hold until a sufficient material buffer has been accumulated on site. For example, pipe spool installation is not typically started until a significant portion of the total pieces to be installed (60 to 80%) have been delivered to the site (Howell & Ballard, 1996).

### **3.6.1 Existing Supply Chain Model**

The entire supply network for a typical construction project is composed of a complex system of elements. Modeling such a vast system was considered to be beyond the scale required to complete the intended investigation as part of this thesis. As such, only a single supply chain from within a greater construction supply network was modeled using EZStrobe. The chosen supply chain was that of the piping process typical on industrial construction projects.

The piping process was chosen as the basis for this portion of the investigation due to the availability of literature which provided an understanding of its supply chain structure and the relationships between its constituents. The piping supply chain model presented by Tommelein (1998) proved to be an essential resource. Industrial piping is also a segment of the construction supply network that is known to suffer from the effects of uncertainty as described by Howell and Ballard in their 1996 report entitled *Managing Uncertainty in the*

*Piping Function.* In addition, the selection and modeling of this supply chain ties in with the models previously developed as part of this thesis.

The EZStrobe model developed to represent the existing piping supply chain was broken into two parts. The first part of the model, described in Figure 3.22, depicts the segments of the piping supply chain which relate to the fabrication process. Accordingly, the second part of the EZStrobe model, described in Figure 3.23, depicts the segments which relate to on-site installation. Each part of the piping supply chain model and the associated activities are described in detail below.

### **3.6.1.1 Part 1 – Fabrication**

The first part of the model is composed of those activities which are directly related to the fabrication of pipe spools and associated activities which are based offsite. These activities include the generation of design specifications, the design process, the overall pipe spool fabrication process, and the transfer of material to the site. Figure 3.20 depicts a simplified arrangement of the activities which make up Part 1 of the piping supply chain model. The details of each activity are described in the following sub-sections.

#### **3.6.1.1.1 Generate Specifications**

The *GenerateSpecs* combi activity was incorporated into the model to account for all of the work involved in generating project specifications that must be completed prior to beginning detailed design (see Figure 3.22). This activity is used to initialize the rest of the model by providing the design team with a set of 100 pipe spool specifications. A duration of 0 days was assigned to this activity since in reality the development of project specifications for a large industrial facility (e.g. Nuclear Power Plant) often takes place over a period of a number of years, which may or may not be continuous. As a result, any duration applied to this activity would simply have to be discounted from the overall simulation duration.

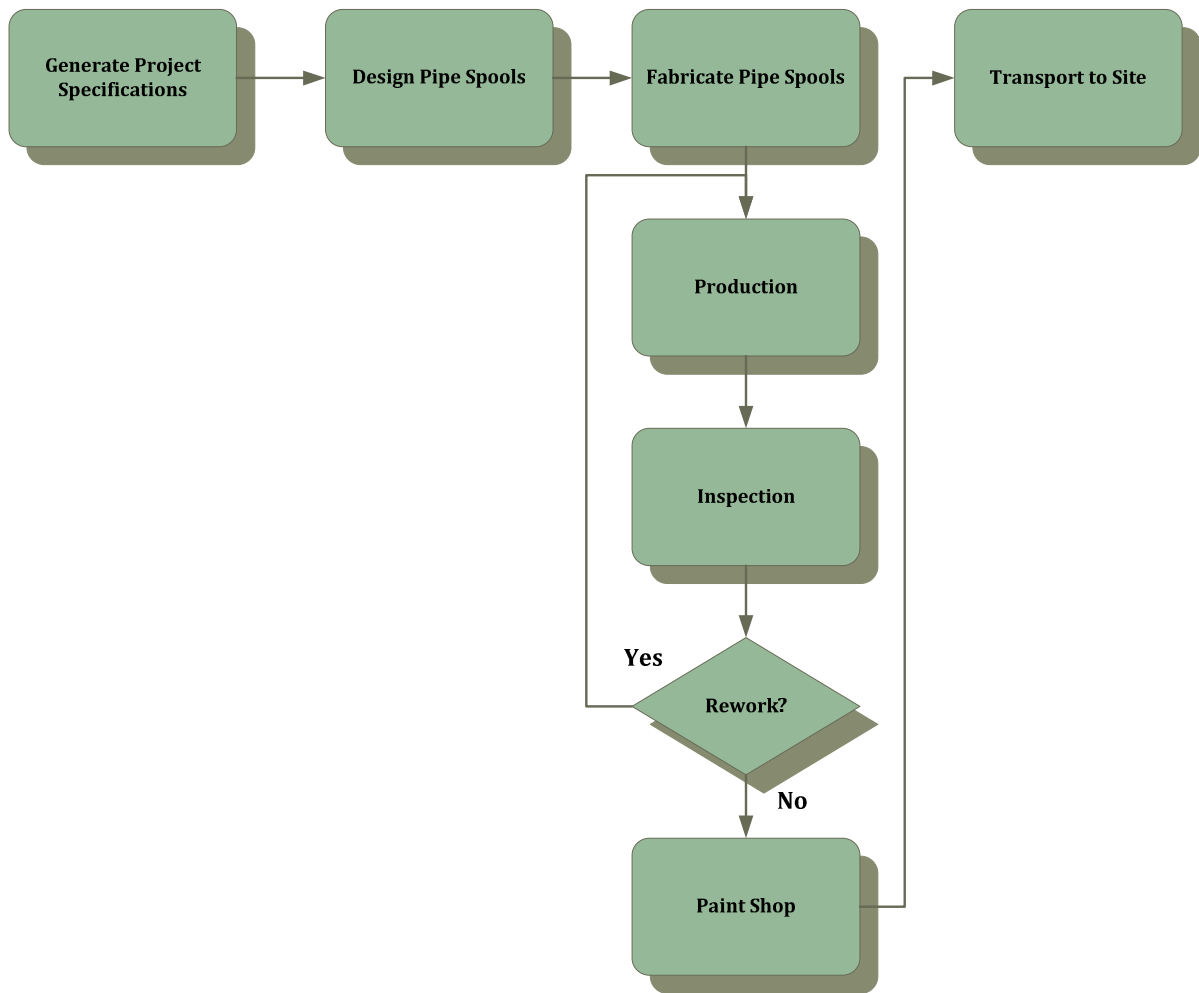

**Figure 3.20 – Simplified Existing Pipe Spool Supply Chain Model Part 1 (Fabrication)**

### **3.6.1.1.2 Design Elements**

Once the specifications for the required piping have been generated, the detailed design of individual pipe spools must be completed. This process is represented by the *DesignElements* combi activity, in connection with the *Wait2Design* and *EngDesign* queues, in the model (see Figure 3.22). Based on the model developed by Tommelein (1998), each specification was assumed to account for a single line of pipe, which subsequently must be broken down into more manageable lengths for fabrication and transportation purposes. Each line of pipe was assumed to be composed of 4 individual pipe spools. Therefore, the

100 specifications inserted by the *GenerateSpecs* activity results in 400 individual pipe spools that are required to be designed, fabricated, and installed.

An overall rate of production of 4 pipe spools per day was assumed throughout the model. This corresponds to processing one specification or designing 4 pipe spools per day. To incorporate a certain degree of randomness into the design phase, a Normal distribution of mean 1 day and standard deviation of 0.15 days was assigned to the duration of the *DesignElements* combi activity. Once a pipe spool design has been completed it is transferred to the fabricator.

### **3.6.1.1.3 Fabrication**

The overall fabrication process is broken down into 3 primary phases in the model. The first phase of fabrication is the actual production of pipe spools. This is accounted for by the *Fabrication* combi activity, in connection with the *FabCrew* queue. Howell and Ballard (1996) reported that a pipe spool requires between 3 and 14 days to pass through each phase of the fabrication process; longer durations being required for pipe spools that must meet special tolerances or are of above average size. The most likely total fabrication duration for a typical pipe spool was estimated to be 5 days. As a result, a triangular distribution of 1, 3, and 12 days, corresponding to minimum, mode, and maximum, respectively, was used to model the duration of the production phase of fabrication. The additional two days were spread over the remaining two phases of the fabrication process. To achieve an estimated production rate of 4 pipe spools per day, 12 fabrication crews were included in the *FabCrew* queue.

The second phase of the fabrication process is inspection. This phase is modeled by the *Inspection* combi activity and the *Inspector* queue. A Normal duration of mean 1 day and standard deviation of 0.15 days was assigned to this activity. The same expected production



rate of 4 spools per day is maintained at this phase of the model by the inclusion of 4 inspectors.

A decision node was incorporated after the inspection phase to account for the possibility that a certain number of spools will not meet the specified quality control standards. The probability that a pipe spool will fail the inspection phase of the fabrication process was assumed to be 10% (Tommelein, 1998). If a pipe spool is deemed to have failed the inspection phase, it must be reworked. This is symbolized in the model by the *ReWork* combi activity. As was the case in Tommelein (1998), it was assumed that a similar amount of time to produce the pipe spool would also be required to complete any rework. This activity also draws upon the same resources as that of the production phase of fabrication process. If a pipe spool is deemed to have passed the inspection phase it is transferred to the paint shop.

The third and final phase of the fabrication process included in the model is the paint shop. This phase of operations is symbolized by the *PaintShop* combi activity and the *PaintCrew* queue. The same 1 day duration and production rate as used in the inspection phase of operations was also applied here.

#### **3.6.1.1.4 Transport**

Once the pipe spools have passed through each phase of the fabrication process they are transferred to the *Wait2Trans* queue. When a sufficient number of pipe spools have accumulated in this queue, in this case 20, they are transferred to the site. This event is accomplished in the model using the *Transport* combi activity. As was done in Tommelein (1998) it is assumed that an unlimited number of trucks are available for transporting material, making the only constraint on this particular activity the specified number of pipe spools. The duration of this activity was modeled using a Normal distribution with a mean of

3 days and a standard deviation of 0.45 days. At this point, the model progresses to the installation stage.

### 3.6.1.2 Part 2 – Installation

The second part of the developed model is composed of those activities which are directly related to the installation of the pipe spools and other associated on site activities. The activities in this part of the model include the material receiving process, the completion of install area preparation, pre-installation work, and final installation. Figure 3.21 outlines the arrangement of these activities within the model. The details of each activity are described in the following sub-sections.

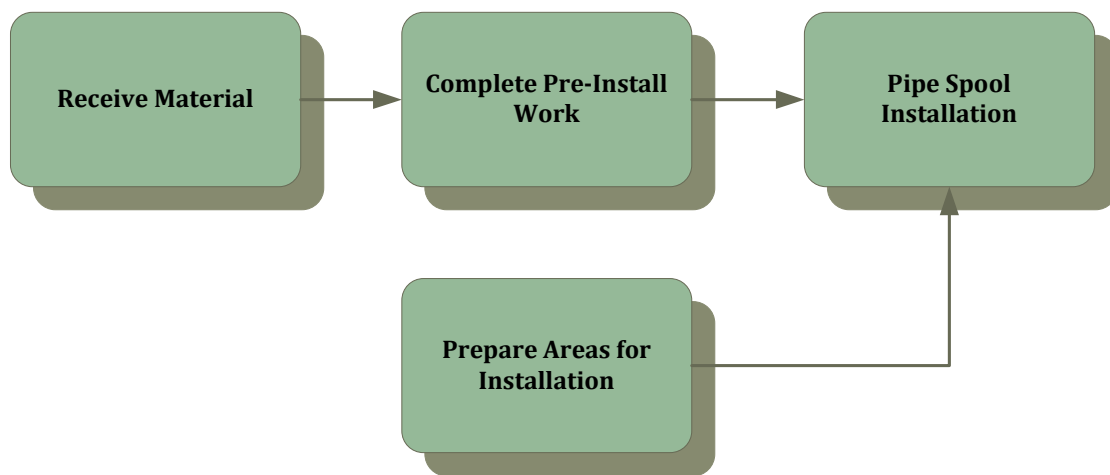

**Figure 3.21 – Simplified Existing Pipe Spool Supply Chain Model Part 2 (Installation)**

#### 3.6.1.2.1 Receive Material

Once the pipe spools have been transferred to the site via the *Wait2Rec* queue they are available to be received following a similar process as described in Section 3.4.1. Note that in Figure 3.23 the *Wait2Rec* queue is represented by a Fusion queue element. The receiving process is represented by the *RecMat* combi activity and the *WhsCrew* queue in the model. The duration used for this activity, modeled using a Normal distribution with a mean of 0.2 and standard deviation of 0.03 days, is based on the total average duration used in the model

presented in Section 3.4.1. At the completion of this activity, 20 pipe spools are inserted into the laydown yard, denoted by a queue of the same name, to await the completion of pre-installation work and install area preparation. A unit is also added to the *Counter* queue at the completion of this stage of the model; the purpose of this element will become clear in the next sub-sections.

### **3.6.1.2.2 Install Area Preparation**

Before pipe can be installed, a designated area must first be prepared for installation within the hypothetical facility under construction. In this case, preparation of an installation area could include the erection of structural pipe racks, setting the elevation of pipe supports, and any other prerequisite work that must occur before a series of pipe spools can be installed.

For this model a series of 10 areas must be prepared. Preparation work is accounted for by the *Prep4Install* combi activity and the *Areas2Prep* and *WorkCrew* queues. Each area is assumed to require the same amount of time to prepare and only one area can be prepared at a time. A Normal distribution with a mean of 10 days and standard deviation of 1.5 days was applied to the *Prep4Install* activity.

To account for the completion of site work within the model (e.g. excavation, concrete placement, etc), the preparation of installation areas cannot begin until after an initial 50 working day wait period has passed. The wait period is modeled using the *FieldWork* combi activity element.

An additional constraint upon the area preparation activity is the requirement for a specified minimum number of loads of pipe spools to have been delivered before commencing operations (i.e. material buffer). The minimum number of loads is currently shown as 8 (40% of total number of loads) in Figure 3.23, but this value will be varied during the subsequent investigation. This constraint is intended to account for uncertainty in the pipe spool fabrication process held by construction managers that would restrict their

tendency to commence on-site operations. A draw link from the *Counter* queue to the *Prep4Install* activity element enables this constraint.

### **3.6.1.2.3 Pre-Installation Work**

Once received on site the pipe spools become available for the completion of pre-installation work. Pre-install work accounts for the fitting of valves and other components, cutting down the lengths of spools to match facility as-built conditions, and other related tasks that must be completed before the pipe spools can actually be installed within the facility. This task is depicted in the model by the *PreInstallWork* combi activity and the *PreInstlCrew* queue. A production rate of 4 pipe spools per day was assumed for this stage of the model. Subsequently, the duration of the *PreInstallWork* activity element is modeled using a Normal distribution of mean 1 day and standard deviation of 0.15 days.

A constraint restricting the start of pre-installation work based on the amount of material received was also applied to account for uncertainty held by the piping project manager. The constraint is enabled by the draw link between the *Counter* queue and the *PreInstallWork* activity element.

### **3.6.1.2.4 Installation**

The final stage of the model is the actual installation of the pipe spools. This task is symbolized in the model by the *InstallPipe* combi activity element, in connection with the *InstallCrew* queue. The occurrence of this activity is restricted by the availability of pipe spools in the *PipeReady* queue and the availability of an install area in the *AreaReady* queue. It was assumed that each install area required exactly 40 pipe spools (two loads). Also, for simplicity, it was assumed that the pipe spools available for installation match with one of the available areas within the facility ready for installation. An average installation duration of 10 days per area was used to match the expected rate of production of 4 pipe spools per day.

The activity duration was modeled using a Normal distribution with a standard deviation of 1.5 days.

Like the previous two activities described, the start of installation operations is also constrained by the amount of material delivered to the site. Howell and Ballard (1996) reported that successful projects with heavy pipe installation requirements accumulated at least 60% of all pipe within their laydown yard by the time 20% had been installed. This condition is accounted for in the model by restricting the *InstallPipe* activity via the *Counter* queue to remain inactive until 12 of the 20 loads of pipe spools (60% of total number of loads) have been delivered. The potential to reduce the amount of uncertainty held by on-site constituents of the piping supply chain and subsequently the dependence on material buffers as a shielding mechanism, by increasing the flow of information from within the supply chain, is the focus of the model presented in the next section of this thesis.

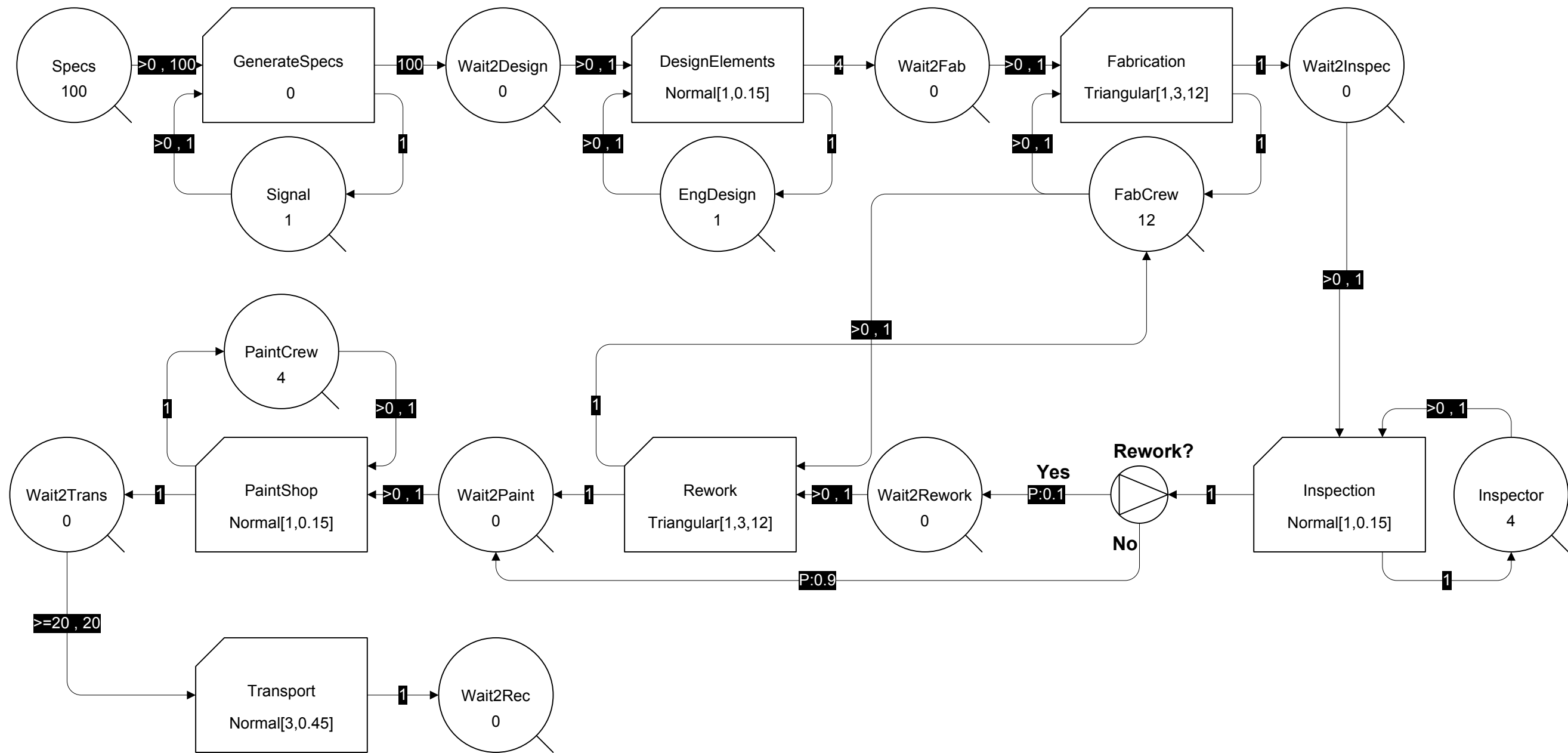

Figure 3.22 – Existing Pipe Spool Supply Chain Model Part 1 (Fabrication)

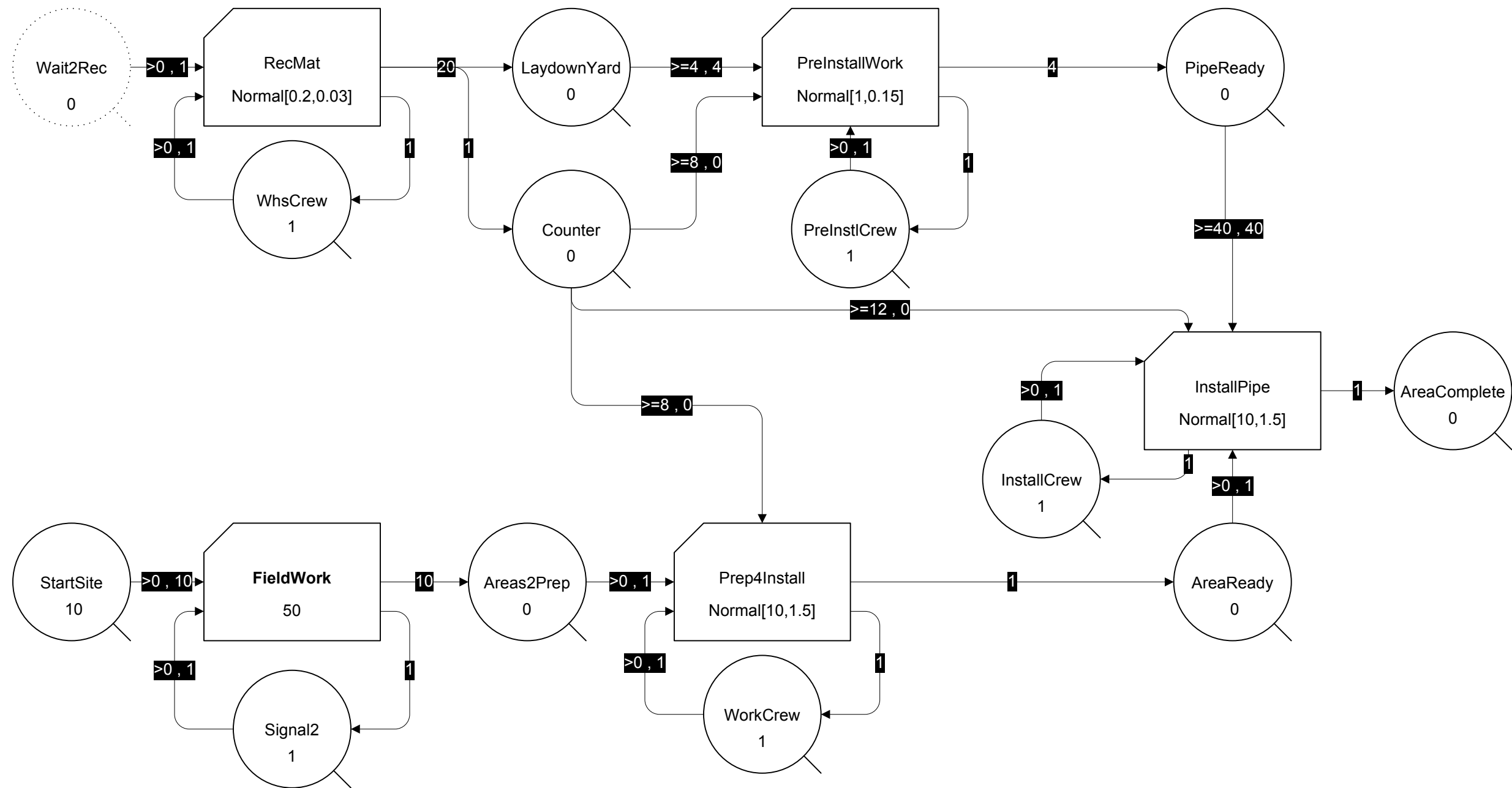
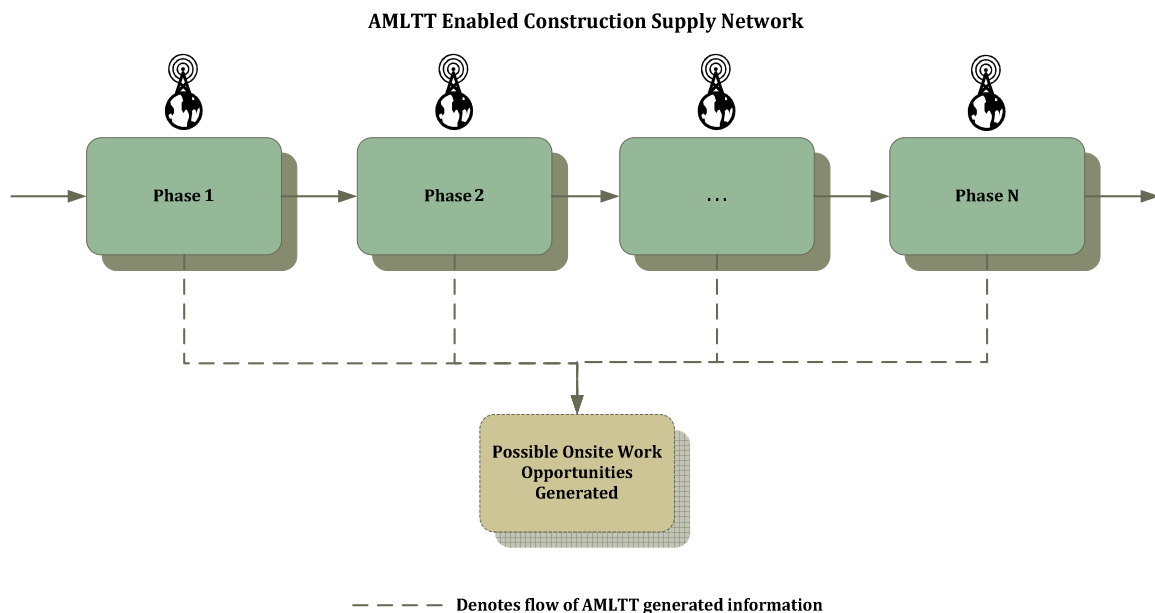

Figure 3.23 – Existing Pipe Spool Supply Chain Model Part 2 (Installation)

### 3.6.2 Modified Supply Chain Model

AMLTT, specifically RFID, employed in conjunction with a comprehensive data management system, offers the potential to drastically improve the ability to transfer information within the construction supply network. This in turn influences the potential to increase supply network visibility and subsequently decrease the level of uncertainty held at the site level concerning the status of material and equipment yet to be delivered. It is theorized that with decreased levels of uncertainty concerning material and equipment deliveries that site based project managers will be able to take advantage of work opportunities that would have otherwise been considered too risky. This concept is presented graphically in more general terms in Figure 3.24. Accordingly, the requirement to build up costly stockpiles of material and equipment in project laydown yards and warehouses, prior to beginning specific construction tasks is expected to be mitigated.



**Figure 3.24 – Increasing Work Opportunities via Improved Supply Chain Visibility**



The theory describe above is explored using the modified piping supply chain model presented in this section. The overall structure of the model is based on the supply chain model presented in Section 3.6.1. In this model, however, it is assumed that AMLTT, in the form of RFID transponders, associated readers, and data management and communication systems, is incorporated into the piping supply chain at the earliest possibly phase. The start of the fabrication process was considered to be the earliest point in which AMLTT could be integrated into the piping supply chain, as this is the first point in which a physical entity exists that a RFID transponder can be affixed to. With the increased use of information technology based tools such as Building Information Models (BIM), the ability to automatically convey information regarding the status of specific items to a central project database may also be extended into the engineering and design phase in the future.

The modified EZStrobe model is divided into three parts. Part 1, described in Figure 3.26, like its predecessor, focuses on the segments of the supply chain related to the pipe spool fabrication process. Part 2, shown in Figure 3.27, is focused on the pipe spool installation process. Part 3, illustrated in Figures 3.28 through 3.30, is comprised of the majority of the additional modeling elements required to incorporate the conceptual flow of AMLTT derived information and the mechanism by which possible work opportunities are generated. Each part of the modified model is described in detail in the subsequent sections.

### **3.6.2.1 Part 1 – Fabrication**

The overall arrangement of elements within Part 1 of the modified model (see Figure 3.26) is relatively the same as previously outlined in Section 3.6.1.1. The major activity elements continue to be those associated with generating project specifications, design, and the activities associated with pipe spool fabrication. A number of additional elements, primarily queues, were added to this part of the model to account for points in which material location and status data would be collected via an AMLTT based system.

The first data collection point within the model is located at the beginning of pipe spool production. The *StartFab* combi activity was inserted into the model, with the duration set at 0 days to allow for a unit signal to be passed to three *PosOpGen1* ('Possible Opportunity Generated') (-1, -2, & -3) queues whenever the production of an individual pipe spool begins. This action accounts for the theoretical transfer of material status information to the project database.

The second data collection point within the model is located at the end of the production phase of fabrication. A unit signal is passed to three designated *PosOpGen2* queues in this instance.

The next data collection point follows the completion of the inspection phase of fabrication. If a pipe spool passes through inspection without requiring rework, this information is conveyed directly by a signal to the *PosOpGen3* queues. For simplicity, if a pipe spool fails inspection, the associated information signal is held back until the required rework has been completed. In reality, knowing that a specific item had failed a quality assurance inspection would be just as important as knowing that it had passed.

The subsequent data collection points within Part 1 of the modified model occur when a pipe spool passes through the paint shop and when a series of pipe spools are removed for transport. In each instance a unit signal is passed to the *PosOpGen4* and *PosOpGen5* queues, respectively.

Each signal collected in a 'Possible Opportunity Generated' queue represents possible information that may allow for a potential work task opportunity to be taken advantage of at the site level. This concept should become clear in the following explanations of parts 2 and 3 of the modified model.

### **3.6.2.2 Part 2 – Installation**

Part 2 of the modified pipe supply chain model (see Figure 3.27) is also structured relatively the same as that of the existing model, except for the addition of a number of new elements. The first series of elements added were the *PosOpGen6* queues connected to the *RecMat* combi activity element. These queues represent 1 of 2 site based AMLTT data collection points. A unit signal is transferred to these queues following the completion of each instance of the receiving activity. Additionally, a *PosOpGen* queue connected to the *PreInstallWork* combi activity element was added. This queue represents the second site based AMLTT data collection point included in the modified model. A unit signal is transferred to this queue following the completion of each instance of the pre-install work activity.

The second series of elements added were three fusion queues, named *Opportunity1*, *Opportunity2*, and *Opportunity3*, respectively. These fusion queues serve as the link between parts 2 and 3 of the model. Part 3 is responsible for converting the information transferred via the *PosOpGen* queues into possible work opportunities on-site. In this model, the *Prep4Install*, the *PreInstallWork*, and the *InstallPipe* activities are no longer constrained by the quantity of loads received on site, but by the availability of potential work opportunities that arise as a result of information conveyed from the various stages of the supply chain. This is further explained in the following sub-section.

### **3.6.2.3 Part 3 – Work Opportunity Generation**

As previously mentioned, the purpose of Part 3 of the modified model (see Figures 3.28 - 3.30) is to convert hypothetical material location and status data collected at the specified points in the model into information that could potentially result in work opportunities at the site level. Part 3 is divided into three sets of activity elements or subroutines. Each subroutine is responsible for generating the work opportunities for the *Prep4Install*, the *PreInstallWork*, or the *InstallPipe* activity in Part 2 of the model. For example, subroutine 1

(see Figure 3.28) is connected to the *Prep4Install* activity element in Part 2 via the *Opportunity1* queue.

The subroutines that make up Part 3 of the model are activated when a unit signal is passed to one of the numbered *PosOpGen* queues (e.g. *PosOpGen11* - collection point 1, subroutine 1). This signal represents the transfer of data collected via AMLTT to a central project database. A series of fusion queues, one for each *PosOpGen* queue, links parts 1 and 2 of the model to each subroutine. When a signal is received within a subroutine, it is passed, via a combi activity with duration set to 0 (included only because of syntax requirements), to a corresponding decision node. The decision node represents the conversion or the filtering of the collected data into potentially useful information. Note the distinction made between data and information. Depending on the subroutine and the point in the supply chain from which the data point originated, the probability that it represents an exploitable piece of information was assigned accordingly. For example, data collected at the start of pipe spool production was assigned a low probability (e.g. < 1%) of being converted into useful information for all three subroutines. If the collected data can be exploited (i.e. is not filtered out by the decision node) a work opportunity is generated. This is modeled by the transfer of a unit signal to the corresponding *Opportunity* queue. The overall structure of the data filtering mechanism employed in the subroutines in Part 3 is described in Figure 3.25. It should be noted that for this model the relative importance of information is considered from the perspective of the site project manager only. In reality, data collected at all points within the supply chain has the potential to be converted into useful information for other constituents of the supply network.

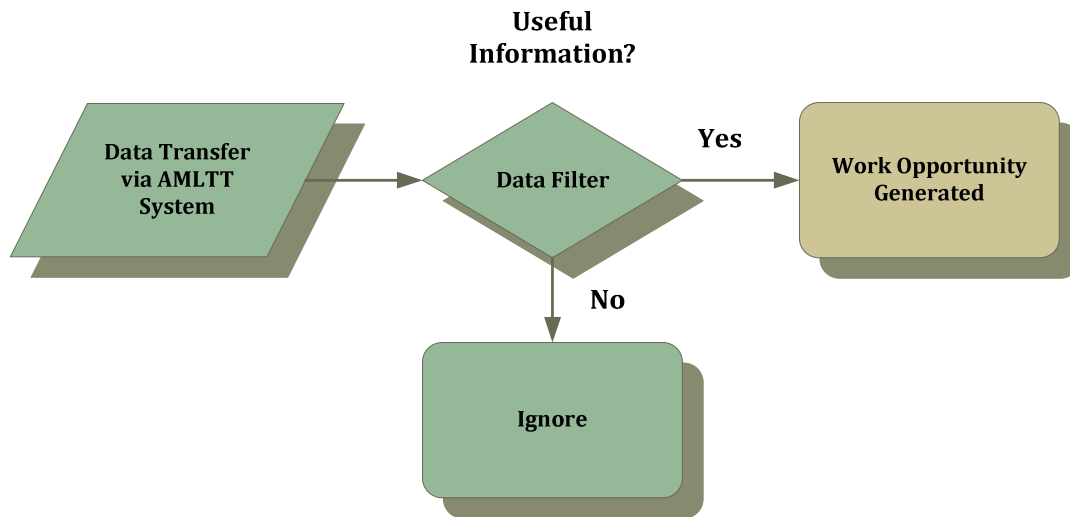

**Figure 3.25 – Structure of Data Filter Mechanism in Part 3**

It would be expected that a relatively high probability of a work opportunity being generated would be associated with material status data originating from on-site collection points (i.e. following material receiving and pre-installation work). In most cases this is true. However, to take into consideration the occasions when material arrives on-site early, out of sequence with installation (often caused by fabricators batching all of one size of pipe or structural steel at the same time or due to construction precedence rules), dynamic based probabilities were assigned to these decision nodes. The probability that a data signal will be converted into a work opportunity once a load has been received is based on the total number of loads received up to that specific point in the simulation. The probability that a data signal will be converted into a work opportunity once a series of pipe spools have been made ready for install is based on the total number of pipe spools processed up to that specific point in the simulation. As the number of loads received or pipe spools processed increases, the probability that exploitable information will be generated does as well. Since data associated with knowing that a series of pipe spools has been received or processed on-site may become important in the relatively near future, a feedback loop was also incorporated within these decision nodes. Instead of the data simply being neglected, as was done previously, it has the

potential to generate future work opportunities. After a specified delay period, the initially rejected data signal is reinserted into the *PosOpGen* queue for reprocessing. This cycle will continue until sufficient work opportunities have been generated to complete the specific work task in question.

Note, the collection of information which may reduce or eliminate work opportunities previously generated was not considered explicitly in the model described above. As was touched upon previously, knowledge of a delay or some other negative outcome is just as important to those constituents further down the supply chain or within the greater supply network as is knowledge of a positive outcome. This concept may be explored in more detail in subsequent research efforts related to this overall topic.

This concludes the explanation of the three series of models developed to explore the impact of including AMLTT within different segments of the constructions supply network. Chapter 4 presents the simulation results and corresponding analysis and discussion.

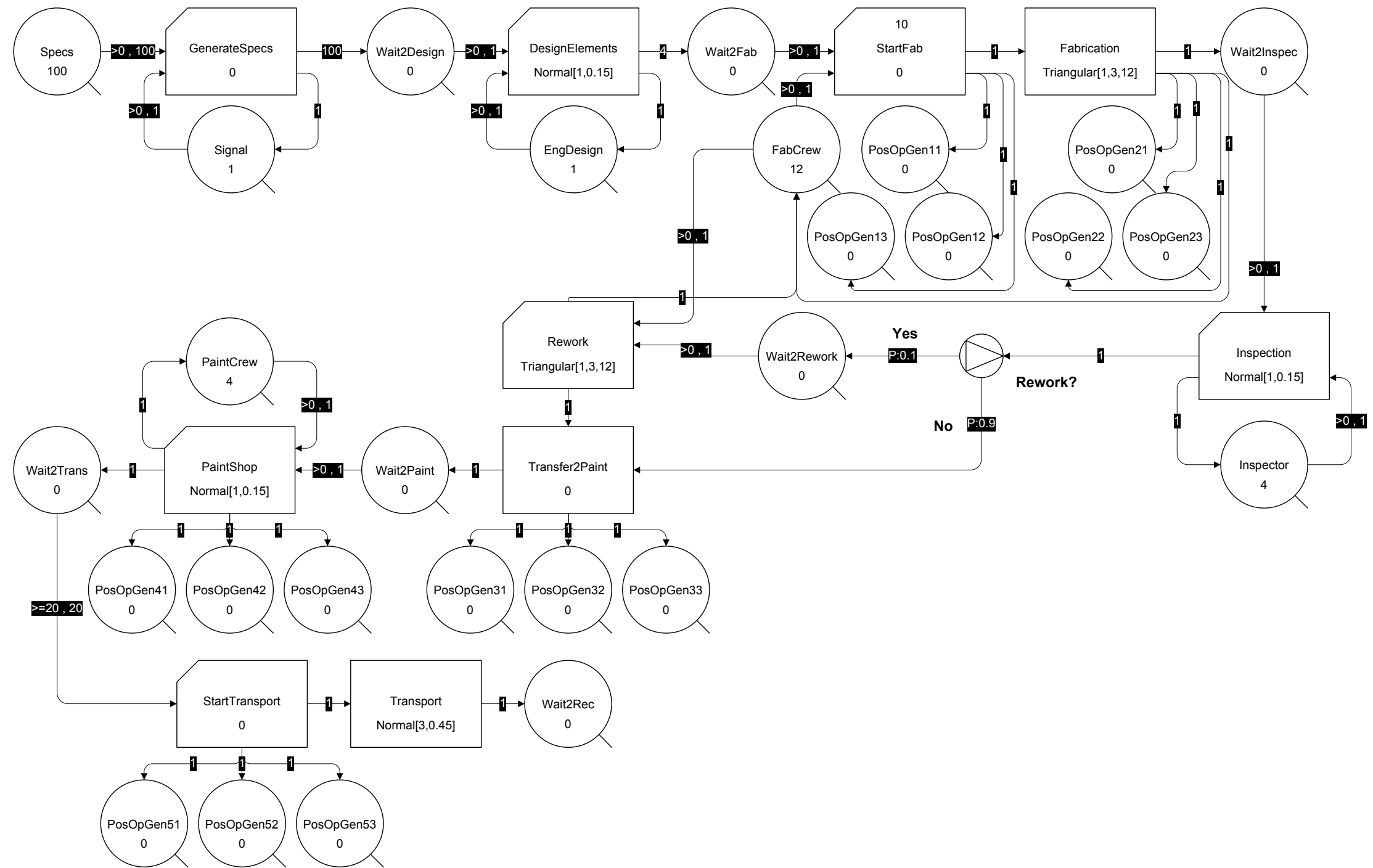

Figure 3.26 – Modified Pipe Spool Supply Chain Model Part 1 (Fabrication)

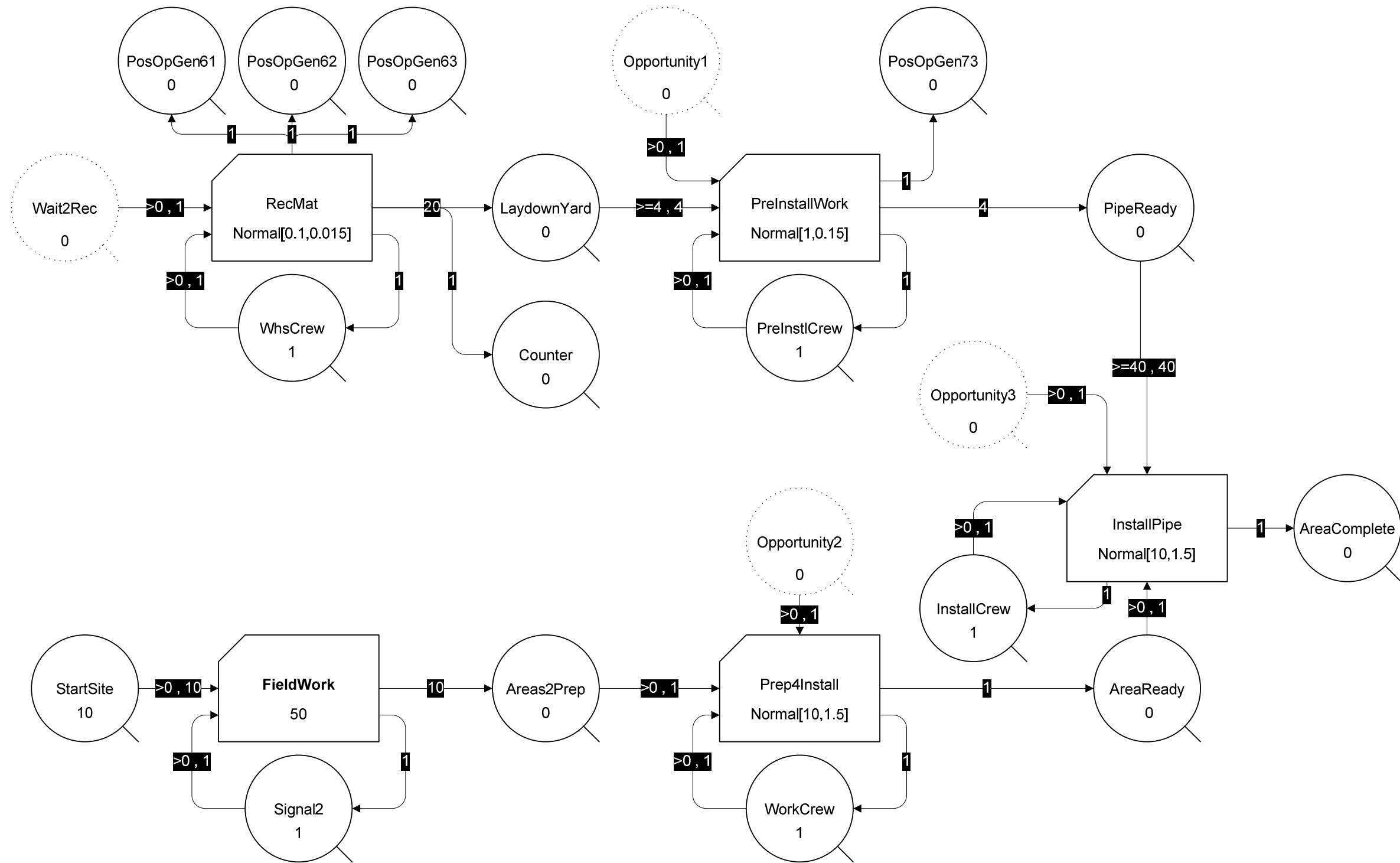

Figure 3.27 – Modified Pipe Spool Supply Chain Model Part 2 (Installation)



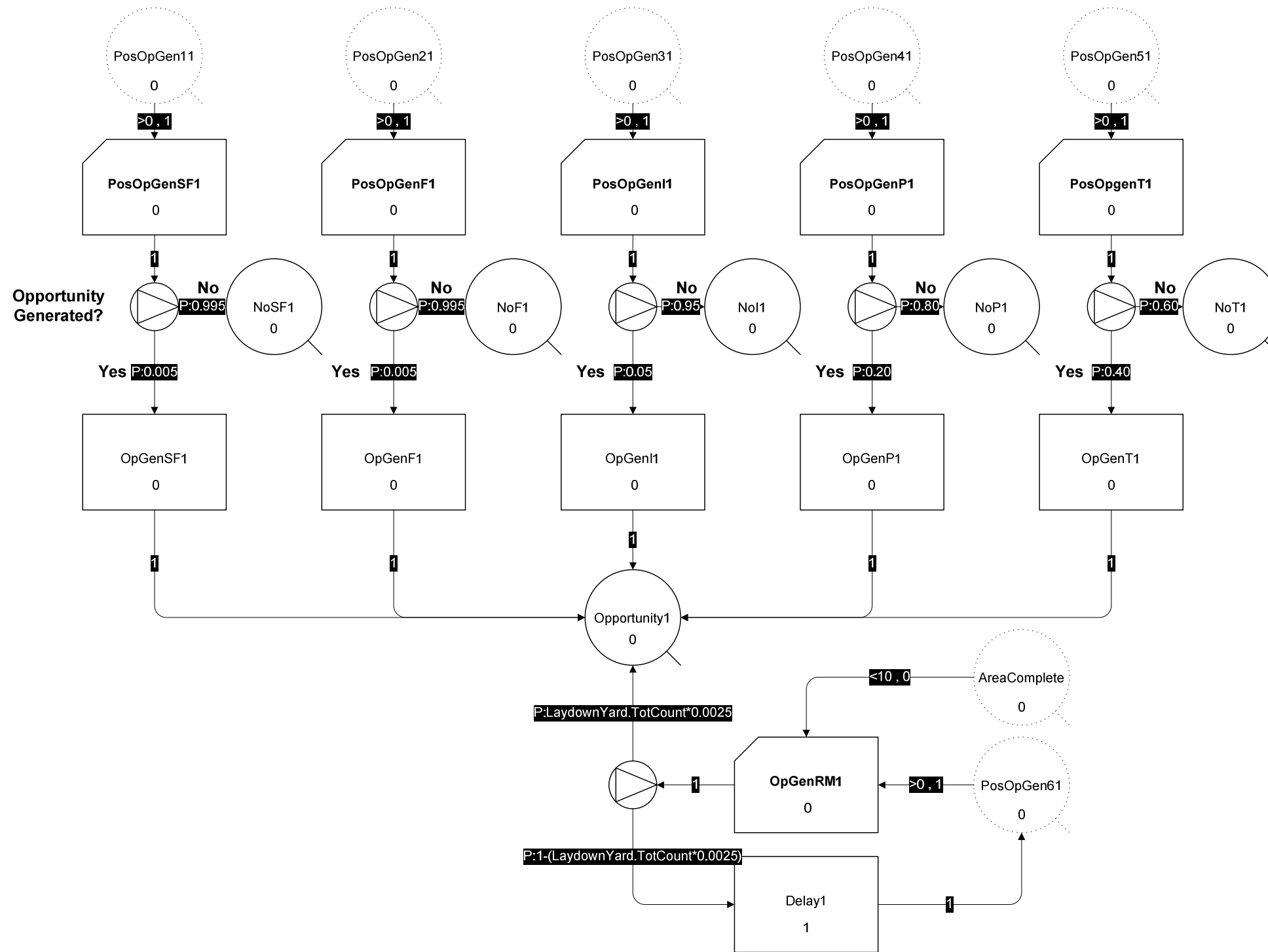

Figure 3.28 – Modified Pipe Spool Supply Chain Model Part 3 - Subroutine 1 (Pre-Install)

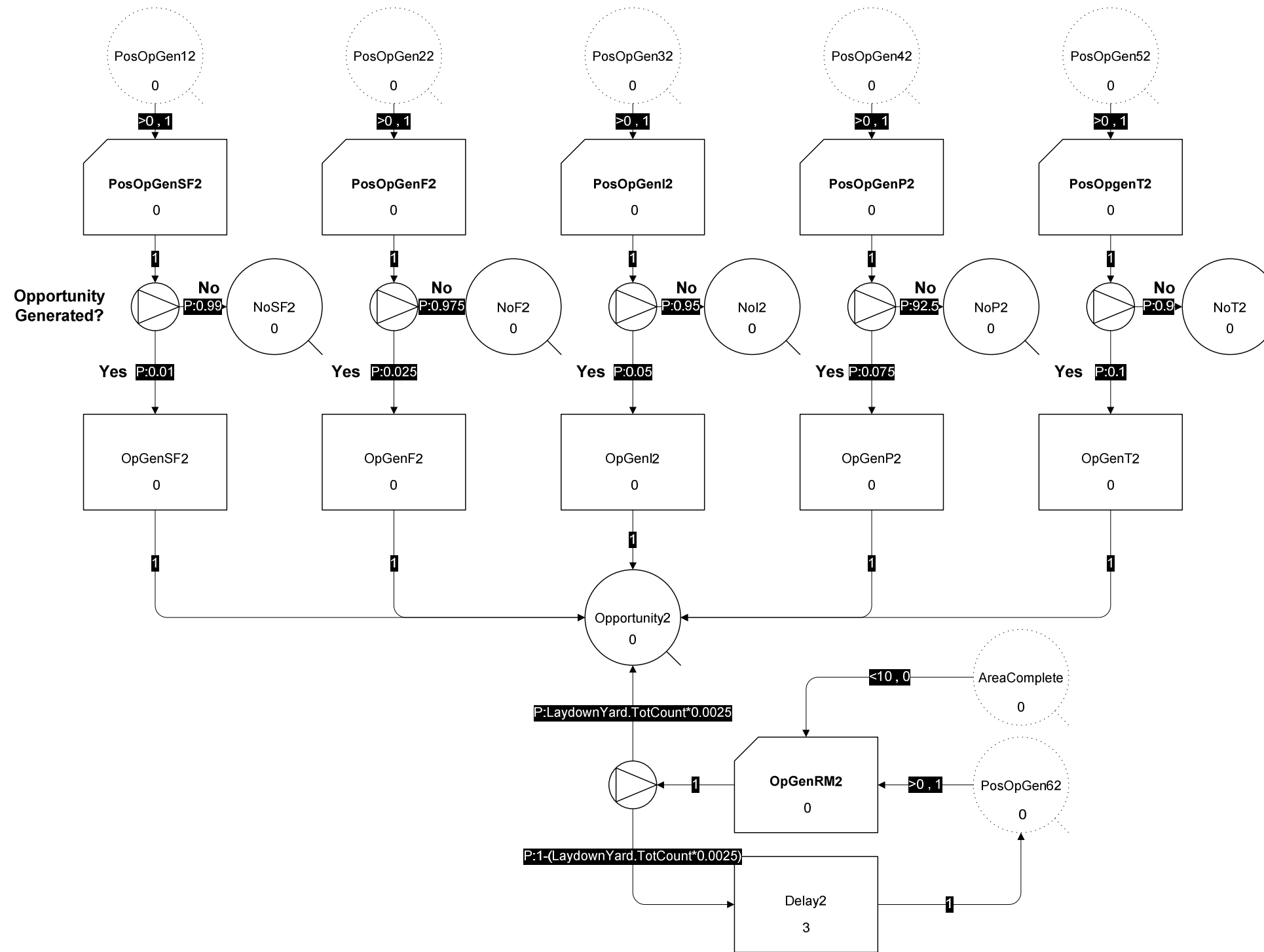

Figure 3.29 – Modified Pipe Spool Supply Chain Model Part 3 – Subroutine 2 (Install Area Preparation)

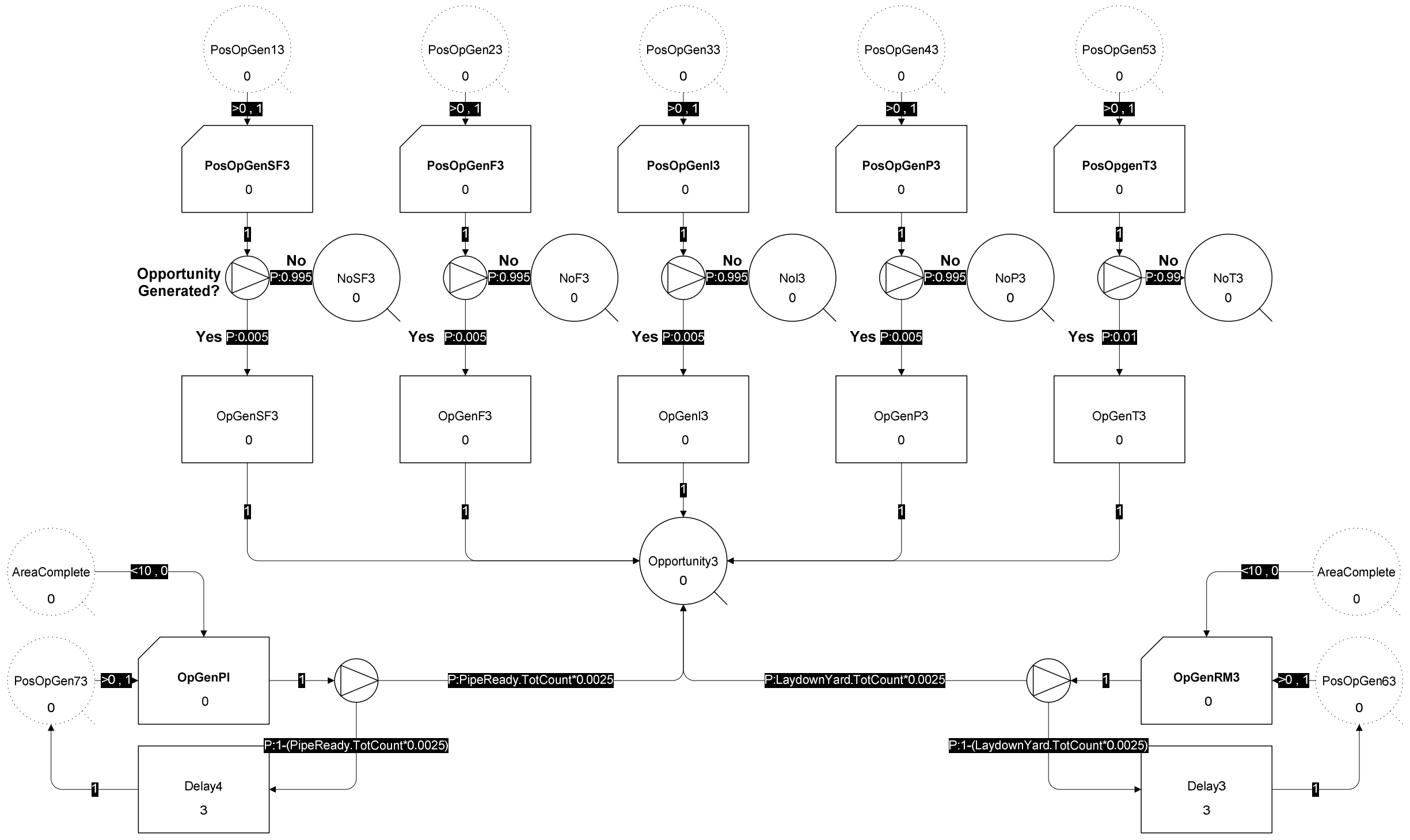

Figure 3.30 – Modified Pipe Spool Supply Chain Model Part 3 - Subroutine 3 (Pipe Spool Installation)

## **Chapter 4**

### **Simulation Results**

#### **4.1 General**

The intent of this chapter is to present and discuss the simulation results for each series of models outlined in Chapter 3. The simulation results are presented in the following order: 1) material receiving, 2) material locating, and 3) increasing supply network visibility. In some cases not all of the results for a particular series of models have been included within the text of this chapter. In such a case, the reader will be directed to the appropriate appendix located at the end of this thesis for the remainder of the results.

#### **4.2 On-site Material Receiving Process**

The overall objective of the material receiving process is to transfer material and equipment delivered to the project from its means of transportation (e.g. airplane, cargo ship, train, truck, etc) to its designated storage or installation location in as efficient a manner as possible. The more rapidly a load of material can be offloaded and received, the earlier that material can be made available to craft workers. In turn, the work crew is also able to proceed to the next material delivery or other tasks more quickly. Therefore, the developed models were used to examine the potential impact that AMLTT could have on improving resource allocation and overall efficiency of the material receiving process.

As a means of measuring model performance, each of the five models was subjected to a varying truck arrival rate. Specifically, the arrival rate was stepped from a minimum of 1 load per day to a maximum of 10 loads per hour. The size of each step in the truck arrival rate was kept constant at 1 load per day within the interval of 1 to 9 loads per day. The size of each step was then changed to 1 load per hour within the interval of 1 to 10 loads per hour. This overall range of arrival rates was applied in attempt to account for the best and worst

case scenarios which might be experienced over the course of a project's duration; the worst case being the delivery of a large amount of material within a relatively short period of time. For each arrival rate, the results of 100 simulations of each model were recorded and the average of each variable measured was calculated. By varying the rate in which loads of pipe spools are delivered to the site, specific advantages and limitations of each material receiving process arrangement (i.e. existing vs. modified) can be readily identified, which may have otherwise gone unaccounted for under an unrealistic assumption of a constant truck arrival rate.

The simulation results for each material receiving process arrangement are presented together for comparison purposes in the subsequent sections. Individual results for each model can be reviewed in more detail in Appendix A. Four principal numerical results are reported for each model. First, the total processing time per load is reported. This quantity is the average amount of time between when a load arrives on-site and when it is transferred to the laydown yard. Next, the operation duration is reported. This result corresponds to the number of days until all of the loads of material have completely passed through the receiving process at the given arrival rate. The daily allocation of the crew and/ or clerk to material receiving related activities is then reported. This factor gives an indication of the amount of labour resources that must be devoted to a particular process arrangement on a continual basis. Finally, the average receiving time per load is quantified. Using this result an efficiency rating was generated for each material receiving process.

#### **4.2.1 Total Processing Time per Load**

The processing time is the average length of time required for a load of material or equipment to pass through a specific material receiving process. This parameter is a summation of: the amount of time required to offload, the time a load waits idle prior to being offloaded and before being received, and the time required to perform the act of

receiving the material items and entering the collected information into the project MMS. The average processing time per load for a given truck arrival rate for each material receiving model is presented in Figure 4.1 below.

For clarity and comparison purposes, the results depicted in Figure 4.1 have been presented in ascending order and not necessarily in the order in which the material receiving models were presented in Section 3.4. Also, all of the results have been plotted in terms of an equivalent truck arrival rate of loads per hour. For example, a truck arrival rate of 1 truck per day is equivalent to 0.1 trucks per hour based on a 10 hour working day. The same horizontal scale is used in subsequent figures as well. A first-in-first-out (FIFO) principle was also assumed.

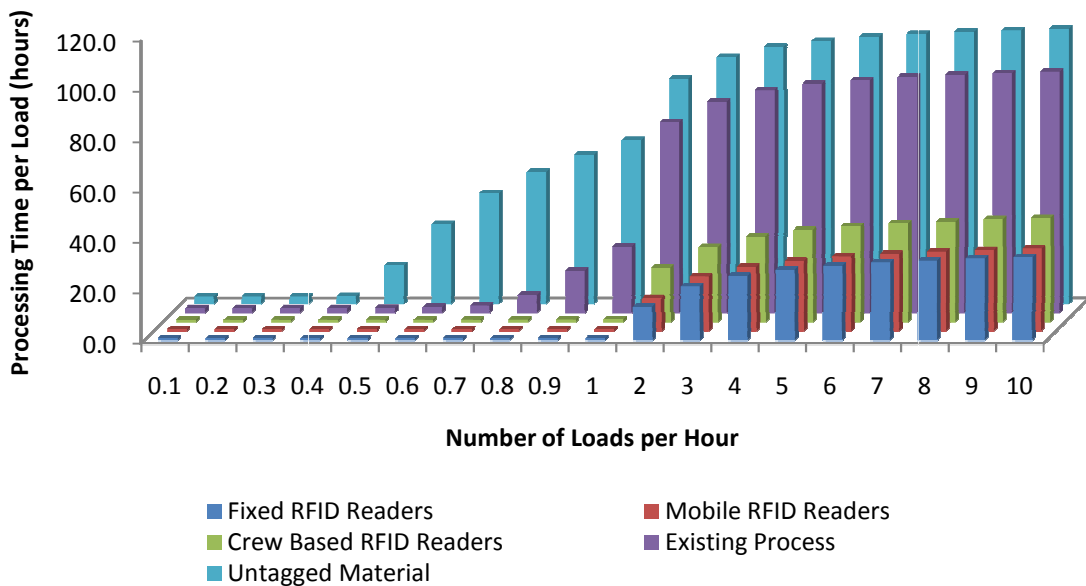

**Figure 4.1 – Total Processing Time per Load**

The total processing time per load varies quite significantly depending on the arrival rate and receiving process being considered (see Figure 4.1). However, for each receiving process considered a typical pattern is exhibited. When a material receiving model is subjected to

relatively low truck arrival rates very little time is required for a load to pass through the receiving process. As the model is subjected to increasing arrival rates a point is reached where a gradual or in some cases a sharp increase in load processing time is recorded. This corresponds to the point where arriving trucks more frequently end up in a queue waiting for the preceding loads to be processed. Eventually, the processing peaks and levels off for the remaining truck arrival rates for which the model is subjected to.

The most significant increases in load processing time were recorded for the existing material receiving process model (see Figure 3.5) and the model which considered untagged material (see Figure 3.15). Recall that the untagged material model is an extension of the existing process model. At one extreme the existing process model experiences a minimum processing time of approximately 2 hours per load within the range of 0.1 to 0.5 loads per hour (1 to 5 loads per day). At the other extreme a processing time exceeding 90 hours per load was recorded for arrival rates greater than 5 loads per hour. In terms of the untagged material model, a minimum processing time of 3 hours per load (0.1 to 0.3 loads/ hour) and a processing time exceeding 100 hours per load ( $\geq 4$  loads/ hour) were recorded. In both cases, the majority of the extended processing durations are associated with non-receiving related activities, specifically load idle time incurred prior to both offloading and the completion of the material receiving activity. In fact, as shall be discussed in a later section, the average receiving time per load remained unchanged regardless of the material delivery rate. Overall, the results presented indicate that potentially significant material backlogs can arise for the existing material receiving process model and by extension the untagged material model when subjected to increased material arrival rates.

In contrast, the models which incorporated the use of AMLTT, in the form of both fixed and mobile RFID readers (see Figure 3.8, Figure 3.11, & Figure 3.13) and pre-tagged materials, were able to incur a greater arrival rate with relatively no increase in load

processing time. A minimum processing time of approximately 0.8 hours per load within the range of 0.1 to 1 load per hour was recorded for both the fixed RFID reader and mobile RFID reader models. A slightly higher minimum processing time of approximately 1 hour per load within the same range of arrival rates was recorded for the crew based RFID reader model. A maximum processing time of approximately 30 hours per load for arrival rates greater than 6 trucks per hour was recorded for both the fixed and mobile RFID reader models. Again, a slightly higher maximum processing time of approximately 40 hours per load for arrival rates greater than 7 trucks per hour was recorded for the crew based RFID reader model. While all the AMLTT based models still exhibited a point at which the time to process a load incurred a significant increase, the magnitude of that increase was much lower than observed in the other models. The decrease in the magnitude of the spike in load processing time can be attributed to reduced load idle time. Where the existing process and untagged material models were hampered by large load idle times at two locations, the AMLTT based models only experienced load idle time prior to the offloading activity. Unfortunately, automating the material receiving task has no impact on the physical task of offloading a load of pipe spools.

#### **4.2.2 Operation Duration**

Operation duration accounts for the interval of time between when the first load arrives on site and when the last load has finished passing through the receiving process. The operation duration recorded for a given truck arrival rate for each material receiving model is summarized in Figure 4.2 below. In this case, each unit of time along the vertical axis corresponds to a 10 hour working day.



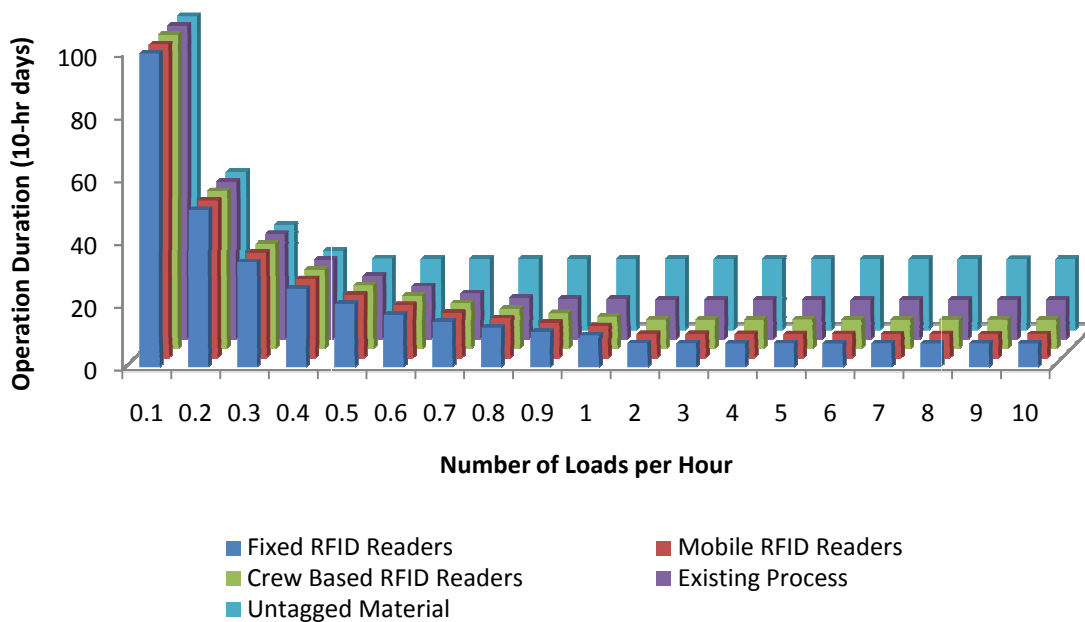

**Figure 4.2 – Operation Duration**

A gradually decreasing trend with regards to operation duration was recorded for each material receiving model recorded (see Figure 4.2). For relatively low truck arrival rates (i.e. 0.1 to 0.4 trucks per hour or 1 to 4 trucks per day) the total operation duration for each receiving process is constrained by the delivery rate. For example, the operation duration for an arrival rate of 0.1 trucks per hour is 100 days in each case (100 loads/ 1 load per day = 100 days). As each model was subjected to increasing arrival rates a point was reached where no further decrease in operation duration was achieved. At this point, the overall receiving process is no longer constrained by the arrival rate of trucks delivering material, but by the composition of the receiving process.

The transition point in which the material receiving process became the primary constraint on operation duration corresponded to slower truck arrival rates for both models which did not directly incorporate AMLTT into the receiving process. In the case of the existing

process model, the minimum operation duration was recorded to be approximately 13 working days (10 hours per day) for arrival rates greater than or equal to 0.8 trucks per hour (8 trucks per day). For the untagged material model the minimum operation duration was recorded to be approximately 23 working days for arrival rates greater than or equal to 0.5 trucks per hour (5 trucks per day).

For the remaining models, which all incorporate AMLTT into the receiving process in some way, the minimum operation duration was reached at a truck arrival rate of 2 trucks per hour. In the case of the fixed and mobile RFID reader models the minimum operation duration was recorded to be approximately 8 working days. A slightly higher minimum operation duration of 9 working days was recorded for the crew based RFID model. In both cases, an improvement of approximately 40% over the existing process model and 65% over the untagged material model in terms of operation duration was recorded.

The overall importance of reporting operation duration is evident when considering the labour resources required to be allocated to each material process arrangement for a given arrival rate on a continual basis. The transition point described here not only corresponds to when the material receiving process in question becomes constrained by its overall arrangement, but also the point in which dedicated labour resources are required to be assigned for the completion of this activity. The issue of labour resource allocation is discussed in the subsequent section.

#### **4.2.3 Labour Resource Allocation**

For this thesis labour resource allocation corresponds to the percentage of a 10 hour working day in which a specific labour resource must be dedicated to the material receiving process. For each of the models the primary labour resource is the work crew, whose responsibility is unloading material from the delivery truck and in some cases also receiving material. In the case of the fixed and mobile RFID reader models and the untagged material model, a

secondary primary resource in the form of a clerk is also included. As such, the required allocation of the work crew and clerk, where applicable, for each model, has been reported separately in the following sub-sections.

#### 4.2.3.1 Work Crew Allocation

The total daily allocation of the work crew to material receiving related activities for a given truck arrival rate for each model is outlined in Figure 4.3 below. The vertical axis is expressed as a percentage of a 10 hour working day.

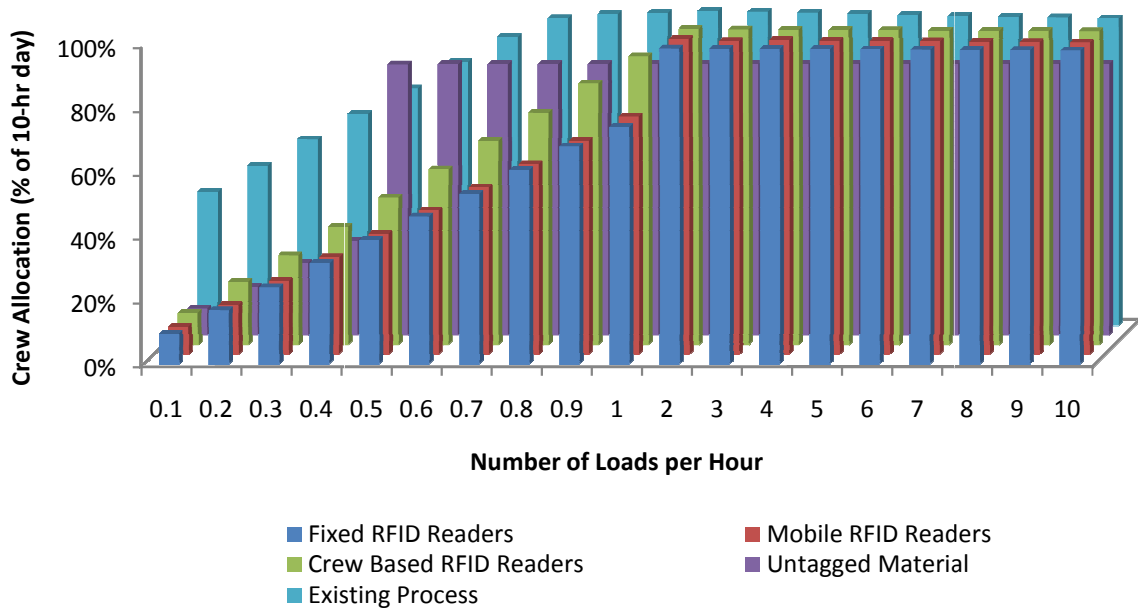

**Figure 4.3 – Work Crew Allocation**

An overall trend of increasing and eventual dedicated allotment of the work crew to material receiving related activities with increased truck arrival rates was recorded for each model (see Figure 4.3). For the arrival rate corresponding to 0.1 trucks per hour (1 truck per day) each of the models, except the existing process model, utilized the work crew for approximately 1 hour out of 10 per day (10% of a working day). For the remainder of the 9

hours until the next load is delivered the work crew is left waiting idle; this is time that the work crew could be assigned to completing other tasks. On the other hand, the existing model required use of the work crew for approximately 4 hours at the same arrival rate of 0.1 trucks per hour; the extra time being required since the work crew is also responsible for receiving the material delivered. As the truck arrival rate is increased the percentage of time that the work crew is occupied with material receiving related activities also increases. For all of the models, except for the untagged material model, the amount of time allocated to material receiving peaks and plateaus at 100%. In the case of the untagged material model, the maximum daily allocation of the work crew was recorded to be 85%. The reduction from 100% to 85% can be attributed to receiving and tagging of material, which is performed by the clerk, requiring more time to complete than the physical task of unloading. For all of the models the truck arrival rate at which the maximum daily allocation mark was reached corresponds to the same arrival rate at which the minimum operation duration was reached.

Overall, the results indicate that the daily allotment of the work crew to the material receiving process is not significantly affected by the implementation of AMLTT. This is evident as all but one of the models eventually requires a 100% maximum daily allocation of the work crew to the material receiving process. This result would be expected since as was previously stated, the physical task of unloading material, which the work crew is responsible for completing, is not affected by the integration of AMLTT.

The beneficial impact of AMLTT on labour resource allocation, however, can be observed by incorporating the total operation duration, as reported in the previous section. In the case of the existing process model, the work crew is responsible for both unloading and receiving material using at best only semi-automated methods (e.g. barcode readers). As such, the minimum amount of total working days that the work crew must be dedicated to the material receiving process, under the given simulation conditions, is 13 days at even the highest truck

arrival rate (100% of 13 working days). In the case of the untagged material model, the work crew is responsible for only unloading. Even still, at 85% maximum daily allotment, use of the work crew is required a minimum of approximately 19.5 days (85% of 23 working days). In contrast, when considering the crew based RFID reader model, which also uses the work crew to perform both the unloading and receiving activities, the work crew was only required for 9 working days. Similar time savings are found with the remaining two models which incorporate the use of AMLTT. The incurred time savings between the AMLTT and non-AMLTT based models in relation to allotment of the work crew is quite extensive; even when considering that two thirds of the AMLTT based models require an additional labour resource element in the form of a clerk.

#### **4.2.3.2 Clerk Allocation**

The total daily allocation of the clerk to material receiving related activities for a given truck arrival rate for each applicable model is outlined in Figure 4.4 below. A similar trend of increasing and eventual dedicated allotment of the clerk as compared to that depicted in Figure 4.3 was also observed for each of the three models. Like in the previous section, substantial differences in the daily allotment of the clerk to the material receiving process were recorded based on whether the model was AMLTT based or not (see Figure 4.4).

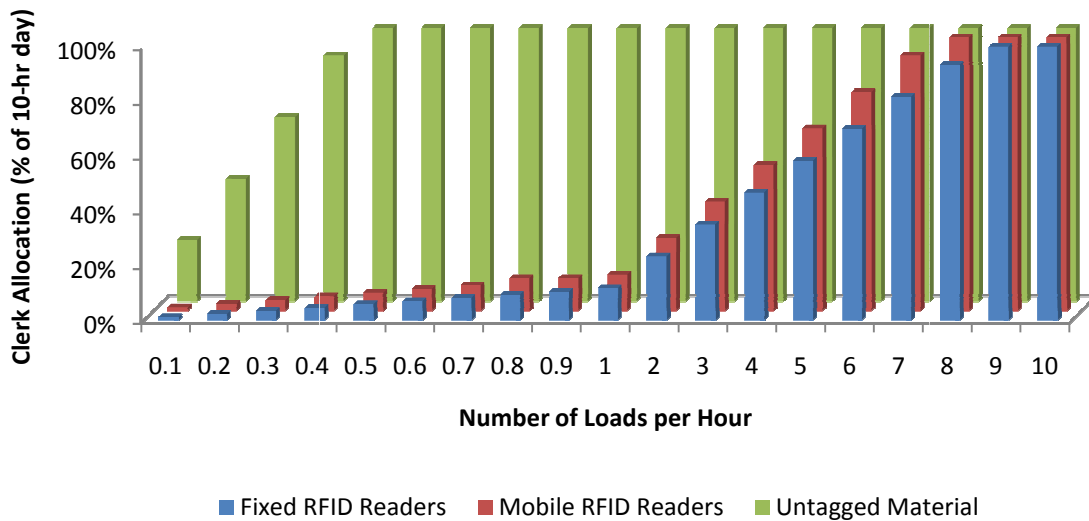

**Figure 4.4 – Clerk Allocation**

The only model which is not AMLTT based, but also makes use of a clerk is the untagged material model. The clerk forms a substantial component of this model as he is not only responsible for receiving the delivered material, but also for the extra activities associated with affixing RFID transponders. As such, the clerk’s rate of utilization on a daily basis is quite high, as compared to the other models, even for relatively low truck arrival rates. Like the work crew, the peak daily allocation is reached when the model is subjected to a truck arrival rate of 0.5 trucks per hour (5 trucks per day) or greater. The maximum daily allocation for the clerk is 100% as compared to only 85% for the work crew. Accordingly, the clerk is required for the complete 23 days, which corresponds to the minimum operation duration, for which the material receiving process is completed.

The fixed and mobile RFID reader models are the only two AMLTT based models which make substantial use of a clerk within the material receiving process. The rate in which the daily utilization of the clerk increased with changes in the truck arrival rate was

approximately the same for both of these models. However, for these two models the point at which 100% utilization of the clerk was reached did not correspond with the transition point reported for operation duration and the work crew utilization (2 loads per hour). Instead, 100% use of the clerk for the fixed RFID reader model was not reached until the model was subjected to a truck arrival rate of 8 or more trucks per hour. In the case of the mobile RFID reader model, 100% utilization of the clerk was reached at a truck arrival rate of 9 trucks per hour. Based on these results, considerably less of the minimum operation duration for each of the models in question is associated with receiving material, but is instead associated with the physical task of unloading.

When taken in context with operation duration results presented in Section 4.2.2, the impact of AMLTT on labour resource allocation becomes evident. Significant time savings in terms of daily work crew allocation were estimated when the manual task of material receiving was replaced with an automated approach facilitated by the work crew itself or assigned to a secondary clerk. In the cases where receiving was performed by a clerk, time savings were again estimated when AMLTT had been implemented prior to the material arriving on site. In each case the time savings are a direct result of the reduced time required to receive a load of material.

#### **4.2.4 Average Receiving Time & Overall Efficiency Rating**

The average receiving time corresponds to the summation of time required to complete the activities associated with receiving a load of material and making it available for pick up within the project laydown yard. Unlike the other factors reported thus far, receiving time for each model was not affected by varying the truck arrival rate. A constant average duration was reported, which was to be expected. The average receiving time associated with each model has been reported in Figure 4.5 for comparison purposes.

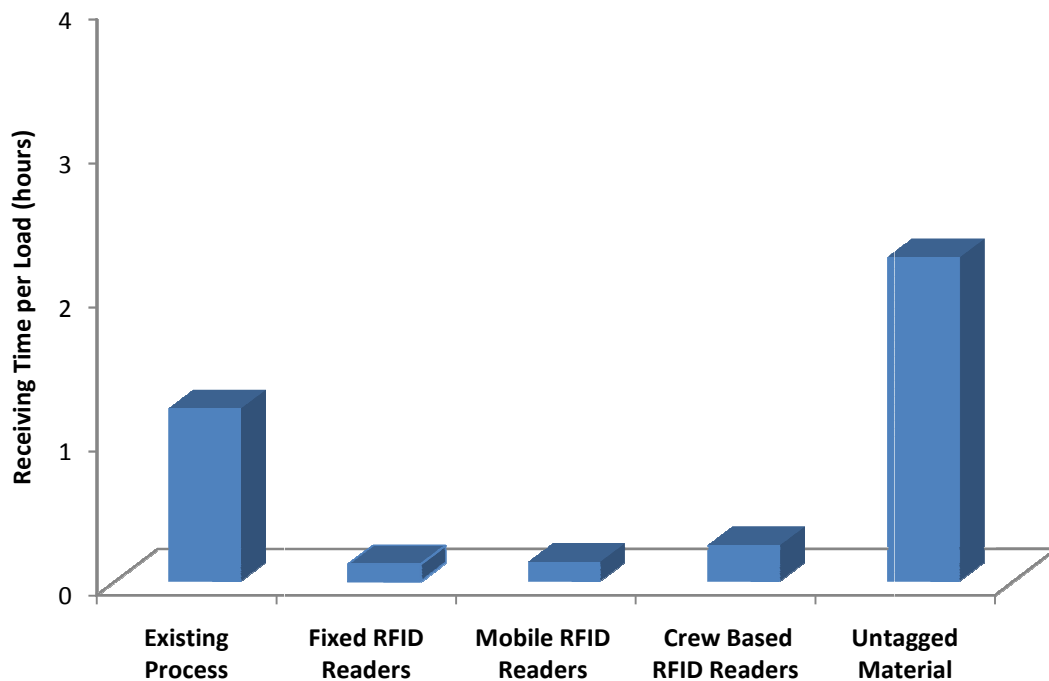

**Figure 4.5 – Receiving Time per Load**

The variation in receiving time per load between the various models is consistent with the differences reported between the results for the other factors. A relatively moderate receiving time of approximately 1.2 per load is associated with the existing process model. The receiving time associated with the untagged material model is higher still at 2.2 hours per load. Each model which incorporates AMLTT in some fashion has a much lower receiving time associated with it. The receiving time per load associated with the fixed, mobile, and crew based RFID reader models are 0.1, 0.13, and 0.25 hours respectively. Using the existing model as a baseline, an efficiency rating was generated for each material receiving arrangement. These ratings are summarized in Figure 4.6 below.



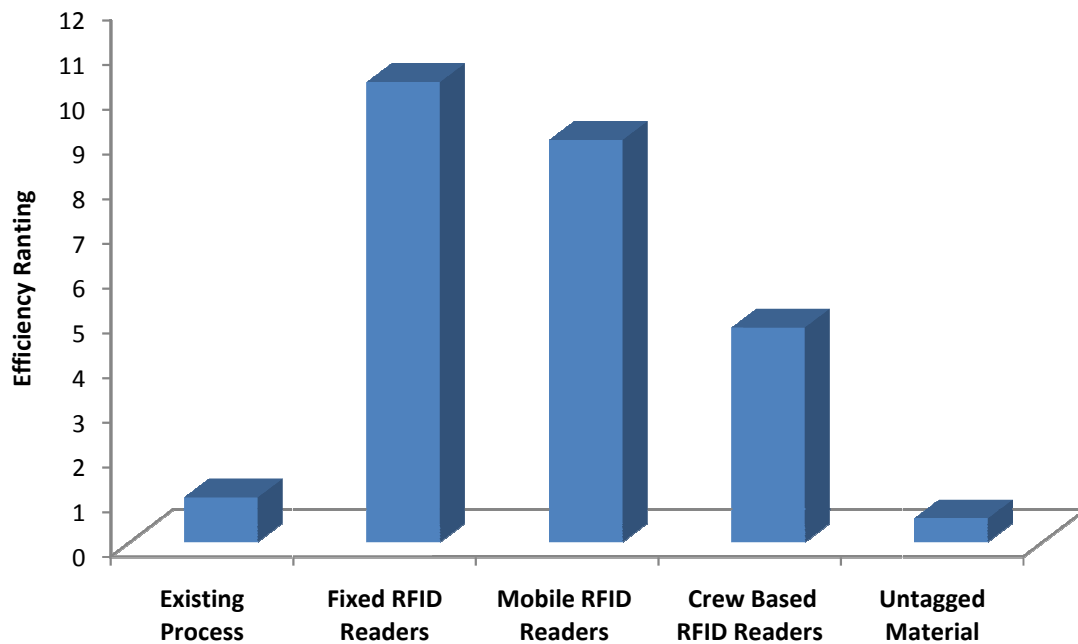

**Figure 4.6 – Overall Process Efficiency Rating**

The efficiency rating for each model was calculated by dividing the average receiving time of the existing process model by the average receiving time of the model in question. The rating assigned to the existing process model is taken as 1. Therefore, an efficiency rating above 1 is considered to be an improvement over the existing process, while a rating below 1 corresponds to a decline in efficiency. The highest efficiency ratings are attributed to the models which incorporate AMLTT directly into the material receiving process, with the fixed RFID reader model having the highest overall rating followed by the mobile RFID reader model and then the crew based RFID model. The magnitude of improvement ranges from slightly more than a factor of 10 at the higher end to a factor of 5 at the lower end. The lowest efficiency rating of 0.5 is attributed to the untagged material model.

At first glance, based on the efficiency ratings presented above, it is evident that being able to incorporate AMLTT within the material receiving process has the potential to lead to significant benefits just in terms of improving the efficiency of material receiving. The most

appropriate form of AMLTT to use (e.g. fixed vs. mobile vs. crew based), however, is highly dependent on the characteristics of the construction project it is being considered for use on. For a more detailed discussion on this issue the reader is directed to *A Model for Automated Construction Materials Tracking* by Hassan Nasir (2008).

Given the current state of AMLTT adoption within the construction industry it is unlikely that every material item or piece of equipment delivered to a project site will be affixed with an RFID transponder. As previously mentioned, what is the most likely outcome in the near future is that a mix of tagged and untagged items will be delivered to the site. If the additional benefits of AMLTT in the form of tracking and locating material and equipment on the project site are to be taken advantage of, each item will require a functioning RFID transponder to be attached to it. The extra labour and capital costs incurred by doing so may well be offset by future savings incurred by being able to locate and distribute those items to craft workers in a timely and efficient manner.

#### **4.3 Locating Material in a Construction Laydown Yard**

The overall objective of a laydown yard crew on a large construction project is to be able to locate material and equipment stored within the yard in a timely and efficient manner. This in turn facilitates a constant rate of production at the work face. As previously discussed, if an item cannot be readily found the consequences can range from a work crew left waiting idle until the item is located to a potentially significant project delay if the item is ultimately declared lost. The purpose of this series of models, therefore, is to illustrate and estimate the potential impact that the implementation of AMLTT can have on improving the ability to locate material within a construction laydown yard and ultimately in reducing the number of items that are declared lost. This has been accomplished using a risk analysis approach.

Unlike the previous series of models presented no parameters were altered or varied during the simulation runs of the two models which make up this series. The reasons for this

decision are as follows. During the initial stages of model development varying the rate at which material locate requests are generated was found to only extend the duration of the simulation as the capacity of the work crew was reached. The overall number of items located at each search stage was found to be unaffected. Changing the probabilities assigned to specific search stages was not considered to be significant as the effects could easily be estimated using hand calculations. As such, both models were run with all of their parameter values set as described in Section 3.5.

Since the composition of the existing and modified process models are not exactly the same, specifically the number of search stages differ, a direct comparison of simulation output has not been completed. Instead, the output for each model has been summarized in the following two sections. Following this, the details of the completed risk analysis are discussed.

#### **4.3.1 Summary of Existing Process Model Output**

The existing process model simulates the current manual approach to locating material within a construction laydown yard (see Figure 3.18). Based on the parameter values assigned, 90% of all items were expected to be located after the initial retrieval attempt. The existing process model, for which the output of 100 simulations was recorded, generated the same average result. Figure 4.7, below, graphically illustrates the proportion of items located after the initial retrieval attempt for the existing process model.

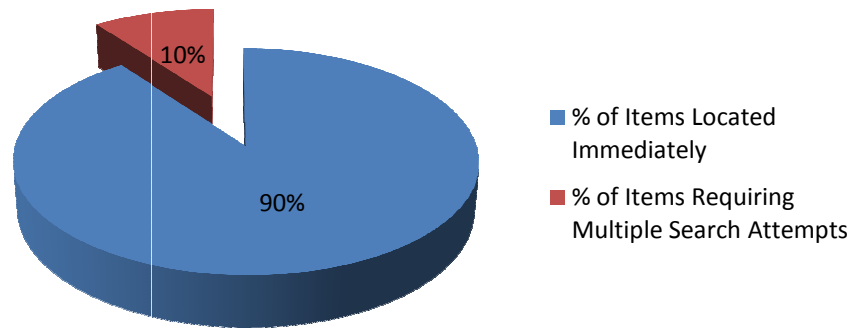

**Figure 4.7 – Percentage of Items Located Immediately**

Of the remaining 10% of items not immediately located, a certain percentage of those items are expected to be located in each of the subsequent search stages or ultimately declared lost, as summarized in Figure 4.8 below.

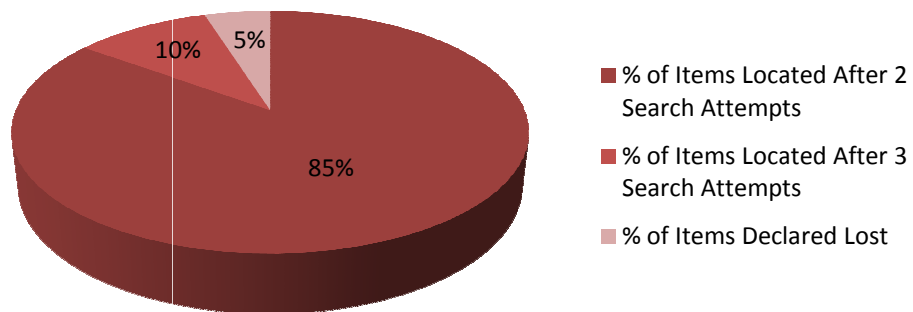
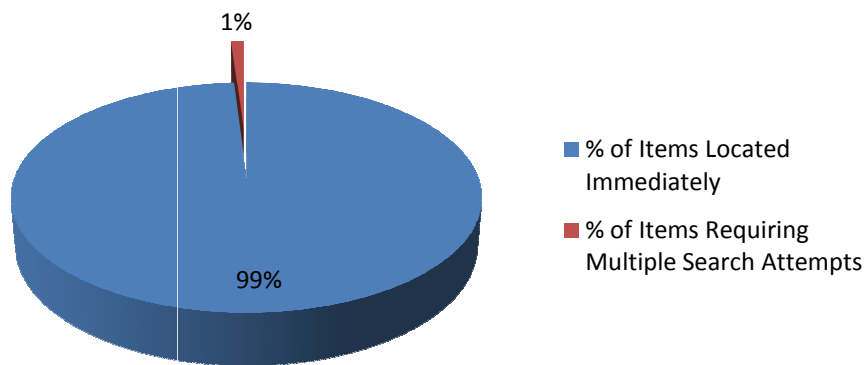

**Figure 4.8 – Breakdown of Items Requiring Multiple Search Attempts**

Within the group of items not immediately found is a small number of items which were considered to be declared lost: approximately 5% of the 10% of item not immediately found or 0.5% of the total number of items located within the laydown yard. It is this small group of items which should be of the most concern for any project manager. There is a relative probability that a critical path and/or high value item may fall within this group if adequate precautions are not taken.

### 4.3.2 Summary of Modified Process Model Output

The modified process model simulates an automated approach to locating material within a construction laydown yard using AMLTT in the form of mobile RFID readers (see Figure 3.19). In the case of the modified process model, 99% of all material locates were expected to be located after the initial retrieval attempt. Similar to the existing process model, the modified model was run for 100 iterations. The expected 99% threshold was reached based on an average of these results. The overall proportion of items located after an initial search attempt using the modified model is illustrated Figure 4.9 below.



**Figure 4.9 – Percentage of Items Located Immediately**

The use of AMLTT provides the ability to perform multiple additional search attempts in quick succession as compared to the existing manual approach. As such, the remaining 1% of items that were not immediately located was divided across multiple search stages as outlined in Section 3.5.2. The proportion of items associated with each of the remaining search stages is summarized in Figure 4.10 below.

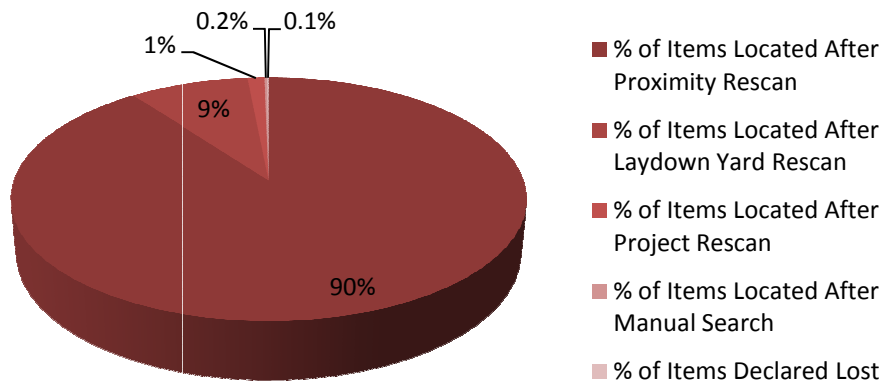

**Figure 4.10 – Breakdown of Items Requiring Multiple Search Attempts**

Based on the parameter values used in the modified model a negligible percentage of the total number of items are expected to be ultimately declared lost when using AMLTT. Even if a more conservative stance had been taken with regards to the percentage of items declared lost, the extremely high probability associated with an item being located within the first search stage, which is based on actual field measurement, would have continued to dominate the overall model output.

### 4.3.3 Risk Associated with Lost Material

Risk can be defined as the product of the probability of occurrence of an event and the impact of that event if it occurs. This concept is outlined mathematically in the equation below. The purpose of this assessment is to estimate the risk associated with the existing manual approach and that associated with the modified AMLTT based approach to material receiving in terms of lost and unfound items.

$$Risk(event_i) = Probability(event_i) \times Impact(event_i)$$

The probability of occurrence of each outcome for both the existing and modified approaches to material locating were based on the estimated percentage of items which fell into each search stage as reported in the previous sections. For example, the probability that an item will be located after the initial search for the existing approach is assumed to be 90%, whereas for the modified approach it is assumed to be 99%.

For this assessment, impact is measured in terms of additional cost incurred by the project due to the loss or replacement of an item. No monetary impact was associated with locating an item after the initial search attempt, since this would be the desired outcome. However, additional labour costs incurred beyond the initial search attempt were assumed to be \$100 per hour per item up to 5 additional search hours. For searches which required between 5 and 10 hours to complete additional project costs were assumed to be incurred, therefore, a cost rate of \$1,000 per hour per item was applied. A relatively conservative replacement cost of \$10,000 per item lost and a \$25,000 per day liquidated damages fee were also used.

The risk assessment of the existing process arrangement is outlined in Table 4.1 below. The average duration for which it took to retrieve an item at a particular search level has been provided for reference.

**Table 4.1 – Risk Assessment of Existing Process Arrangement**

Search Stage	Description	Probability of Occurrence (%)	Search Duration (hours)	Cost Rate per Item	Total Impact/ Stage (\$)	Risk (\$)
1	Initial Search	90%	0.14	\$0	\$0	\$0
2	2 <sup>nd</sup> Manual Search	8.5%	1.7	\$100/hr	\$1,700,000	\$144,500
3	3 <sup>rd</sup> Manual Search	1%	10.0	\$1,000/hr	\$100,000,000	\$1,000,000
4	Item Declared Lost	0.5%	6.4 (days)	\$10,000 + \$25,000/day	\$1,700,000,000	\$8,500,000
		100%			<b>Total Risk</b>	<b>\$9,644,500</b>

The level of risk associated with each stage of the search process varies depending on which factors are controlling the end result. The total impact for the second search stage was estimated to be \$1,700,000; where total impact accounts for the potential impact on the project if all items were located at this stage of the search process. The corresponding level of risk was estimated to be \$144,500. In this case, the relatively high probability that the search for an item will reach the second stage is mitigated by a low impact cost per item. The reverse is true for the third and fourth search stages. The total impact for the third stages was estimated to be approximately \$100 million, with an estimated level of risk of approximately \$1 million. In terms of the fourth stage, the total impact was estimated to be approximately \$1.4 billion, with an estimated level of risk of approximately \$8.5 million. In both of these cases, relatively high impact costs are offset by relatively low probabilities of occurrence. The overall level of risk for the existing process arrangement is, therefore, approximately \$9.65 million.

The risk assessment of the modified process arrangement is presented in Table 4.2 below.

**Table 4.2 – Risk Assessment of Modified Process Arrangement**

Search Stage	Description	Probability of Occurrence (%)	Search Duration (hours)	Cost Rate per Item	Total Impact/ Stage (\$)	Risk (\$)
1	Initial Search	99%	0.05	\$0	\$0	\$0
2	Proximity Rescan	0.9%	0.25	\$100/hr	\$250,000	\$2,250
3	Laydown Yard Rescan	0.09%	0.8	\$100/hr	\$800,000	\$720
4	Project Wide Rescan	0.01%	2.8	\$100/hr	\$2,800,000	\$280
5	Manual Search	0.002%	6.8	\$1,000/hr	\$68,000,000	\$1,360
6	Item Declared Lost	0.001%	5.1 (days)	\$10,000 + \$25,000/day	\$1,275,010,000	\$12,750
					<b>Total Risk</b>	<b>\$17,360</b>



In the case of the modified model, the overall low probability of occurrence associated with a particular search stage dominates the level of risk associated with each stage. The total impact and risk associated with the second search stage, which corresponds to a rescan of the area in close proximity to the last recorded location of the item, were estimated to be \$250,000 and \$2,250, respectively. In the case of the third stage, which corresponds to a rescan of the entire laydown yard, the total impact and risk were estimated to be \$800,000 and \$720, respectively. The total impact and risk associated with a project wide rescan was determined to be \$2.8 million and \$280, respectively. For the fourth search stage, which is a manual search of the site, the total impact and risk were estimated to be \$68 million and \$1,360, respectively. Finally, the total impact and risk associated with items being declared lost were estimated to be \$1.3 billion and \$12,750, respectively. The overall level of risk for the modified process arrangement is, therefore, approximately \$17,500.

By a simple comparison the estimated level of risk associated with the existing manual approach to material locating in a construction laydown yard is significantly greater than that associated with an AMLTT based approach. The reduction in risk from \$9.65 million to \$17,500 is achieved simply by reducing the number of items that enter secondary search stages and most importantly by reducing the number of items that are declared lost. In both cases, the proportion of risk attributed to lost items is quite high. In the case of the existing process model, 88% of the total risk is associated with lost items; whereas, in the case of the modified model unfound items account for 73% of the total risk. However, the difference in magnitude of risk attributed to the final search stage for each of the models is extremely large at close to \$8.5 million.

It is evident by a simple comparison that the AMLTT based material locating process has significantly less risk associated with it. Given that the value placed on each of the lost items could be drastically higher in some cases than was estimated, the actual risk associated with

this search stage could in fact be much higher for both cases. However, the level risk associated with the existing process would continue to outweigh that of the modified process. In this case, it is simply a case of numbers and decimal places. As has been discussed already, the very small percentage of items that can be expected to be declared lost on a typical large construction project has the potential to drastically affect project performance. The implementation of an AMLTT based material locating system, however, has the potential to mitigate that impact.

#### **4.4 Increasing Visibility within the Construction Supply Network**

The ability to meet or exceed a construction schedule is often a primary measure of project success in the construction industry. It not only means turning over the facility to the owner on time, but also often translates into substantial cost savings which in turn equal increased profits. There should be no doubt that accumulating large stockpiles or buffers of material and equipment in laydown yards affects schedule performance. Nonetheless, the accumulation of material buffers over an extended period of time is perceived to be the lesser of two evils. The other perceived alternative is to incur frequent delays in the construction schedule as a result of unidentified and unaccounted for variations in the supply network. However, if these inconsistencies in the supply network could be identified earlier (i.e. via AMLTT) and subsequently accounted for at the site level, there is the potential for schedule performance to be maintained with a much reduced dependency on material buffers. Accordingly, schedule performance was used as the gauge by which the theory that an increased level of supply network visibility via an AMLTT based system can beneficially impact site operations was tested.

A baseline for comparison purposes was first established using the existing supply chain model. Recall, that piping constructors associate an install buffer size of 60% of material delivered with optimum project performance (Howell & Ballard, 1996). Therefore, the

output generated using the existing model subjected to a 60% install buffer was considered to be the most appropriate for comparison purposes. Subsequent analysis of the simulation output associated with other buffer sizes confirmed that the highest level of schedule performance, given other model parameters, was attained with a 60% install buffer in combination with a 55% buffer constraint on the remaining site based activities. The simulation output for other buffer scenarios has been provided in Appendix B for reference.

For both the existing and modified supply chain models, the output associated with six principal activities has been reported. These activities are divided evenly between the off-site fabrication and on-site installation phases of the overall supply chain. The fabrication based activities include the design of pipe spools, the overall fabrication of pipe spools, and the delivery of pipe spools to the site. The installation based activities include the install area preparation, pre-installation pipe spool work, and installation activities. The preceding activities, when combined, give a good overview of the overall characteristics of the supply chain.

A summary of the simulation results for the existing and modified supply chain models have been provided separately in the next two sub-sections. A comparison of the key parameters of the two models follows their individual summaries.

#### **4.4.1 Summary of Existing Supply Chain Model Output**

The existing model output for the case of a 60% install buffer has been presented in the two figures on the following page. First, the population profiles of each activity under consideration over time are provided (see Figure 4.11 below). This figure is useful for gaining an appreciation of the magnitude of queues that form within the supply chain whether due to the inability of a specific process to keep up with the rate of production of a preceding activity or due to the intentional accumulation of an on-site buffer. The length of time for which it takes to accumulate and eventually dissipate these queues can also be

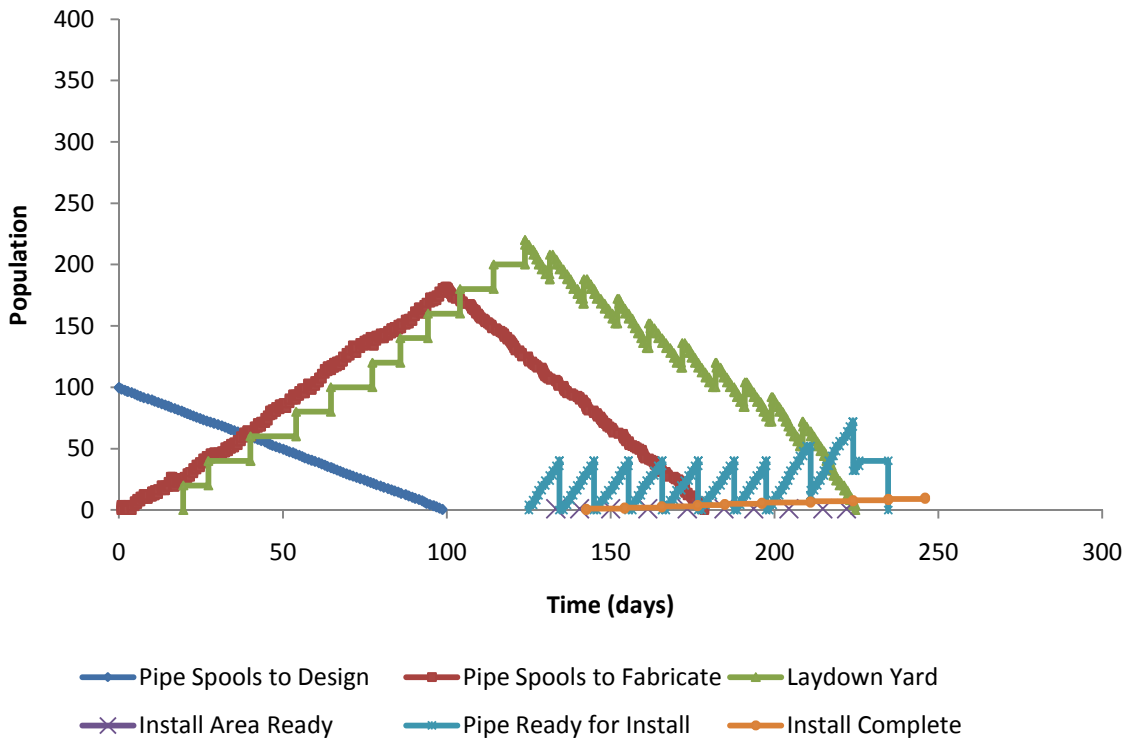

**Figure 4.11 – Population vs. Time – 60% Install Buffer**

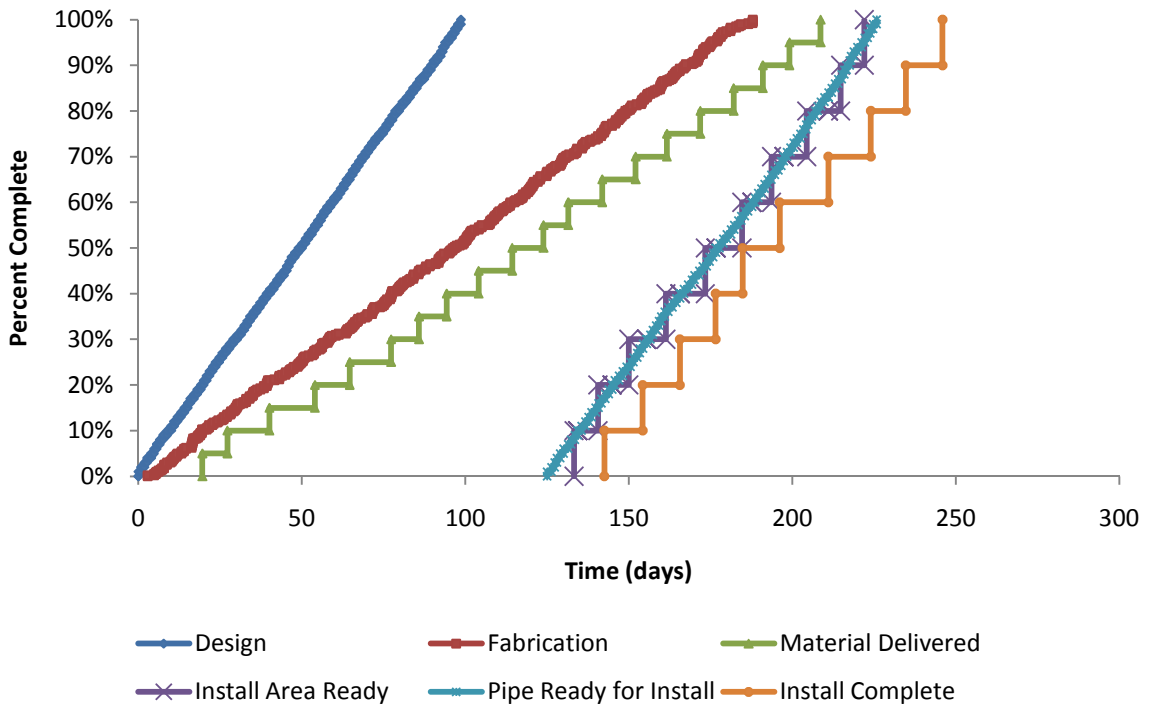

**Figure 4.12 – Percent Complete vs. Time - 60% Install Buffer**

readily gauged from this figure. Next, the percent complete of each activity over time has been provided (see Figure 4.12 below). This figure gives a clear indication of the start and end time, as well as the overall rate of progress of each activity. In turn, the overall schedule performance can be inferred.

In terms of population profiles outlined in Figure 4.11, the two most important to take note of are that of fabrication and the laydown yard (accounts for material delivered to the site). The magnitude and interval of time over which the fabrication population profile spans is an indication that the rate of production of this activity affects the progress of the entire supply chain up to the point of installation. This is confirmed in Figure 4.12. The population profile of the laydown yard clearly depicts the accumulation of an on-site material stockpile in advance of commencing site operations. A period of approximately 105 days is required to meet the first benchmark of 55% of material delivered. An additional 8 days are required to reach the second benchmark of 60% of material delivered.

At the current buffer combination, each site based activity is able to maintain a constant and uninterrupted rate of production as evident from their percent complete profiles (see Figure 4.12). The install preparation and pipe spool pre-install work activities commence operations 124 days after the simulated project kick off. The last area is subsequently made ready for installation at day 222. This finish date corresponds to a rate of production of approximately 1 area prepared every 10 days. This rate of production is in line with the assumed overall rate for this activity. The final set of pipe spools is made ready for installation on approximately day 226. The corresponding rate of production is therefore 3.9 pipe spools per day. This result is also in accordance with the assumed rate of productivity for this activity, although just slightly slower. Installation is subsequently able to commence on day 131. Installation was recorded as being complete on day 246. This translates into a rate of production of approximately 0.9 areas per 10 days. This rate of production is slightly

less than anticipated; however, it can most likely be attributed to the accumulation of incremental delays incurred in upstream activities. Overall, based on a combination of 60% install buffer and 55% precedent activity buffer, the estimated optimum schedule duration for the existing model was recorded to be 246 days. This is the result for which the corresponding output of the modified model will be compared to.

#### **4.4.2 Summary of Modified Supply Chain Model Output**

The simulation output for the modified model output has been presented in the same format as the previous model. Figure 4.13 provides the population profiles for each activity. In addition, Figure 4.14 provides the percent complete profiles for each activity. Both figures can be found on the following page.

Unlike the existing model, the formation of significant on-site material stockpiles does not occur under the modified model (see Figure 4.13 below). The most important changes in population profiles to note are that of the laydown yard and pipe spools ready for installation queues. In the case of the laydown yard, the steady increase and subsequent decline of its population is replaced with a series of population spikes. At no instance does the population of the laydown yard exceed 20 pipe spools. This is one indication that sufficient work opportunities are being generated to allow for on-site activities to commence. Another indication is the formation of a moderate queue of approximately 84 pipe spools made ready for installation. This queue is quickly reduced once installation commences.

Relatively constant rates of production are able to be achieved for each of the three on-site activities under the modified model (see Figure 4.14 below). Sufficient work opportunities were generated to allow for the pipe spool pre-installation work activity to commence immediately following the delivery of the first load of pipe spools on day 20. This activity reached 100% completion 190 days later on day 210. This corresponds to an overall rate of production of 2.1 pipe spools per day. Sufficient work opportunities were also generated to

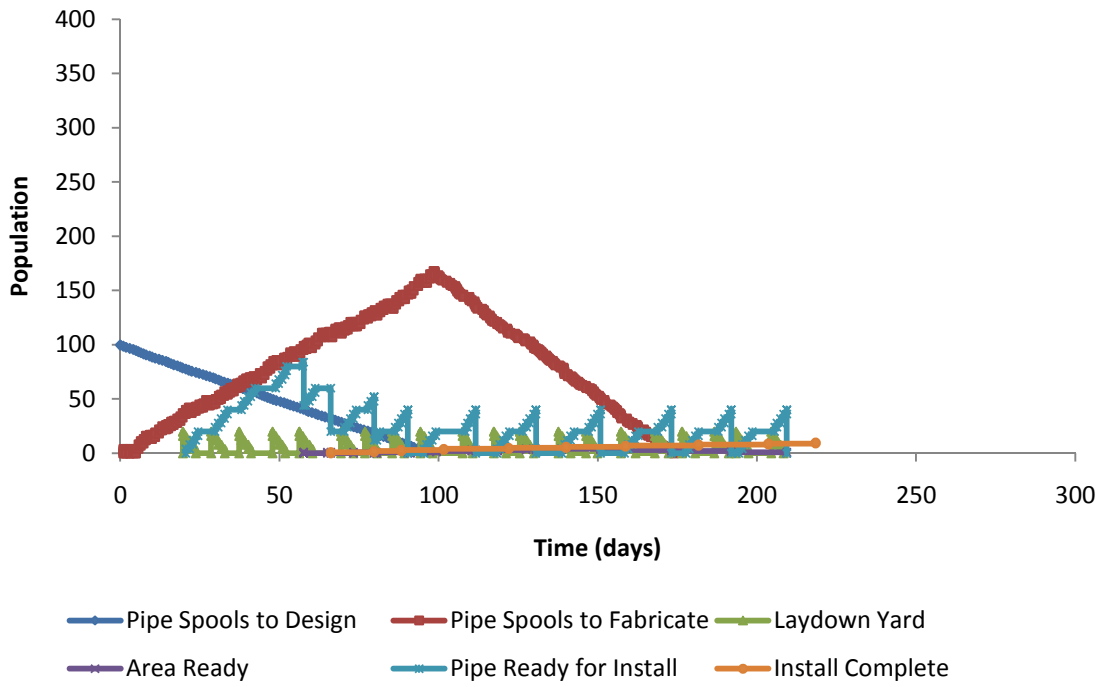

**Figure 4.13 – Population vs. Time - Work Opportunities**

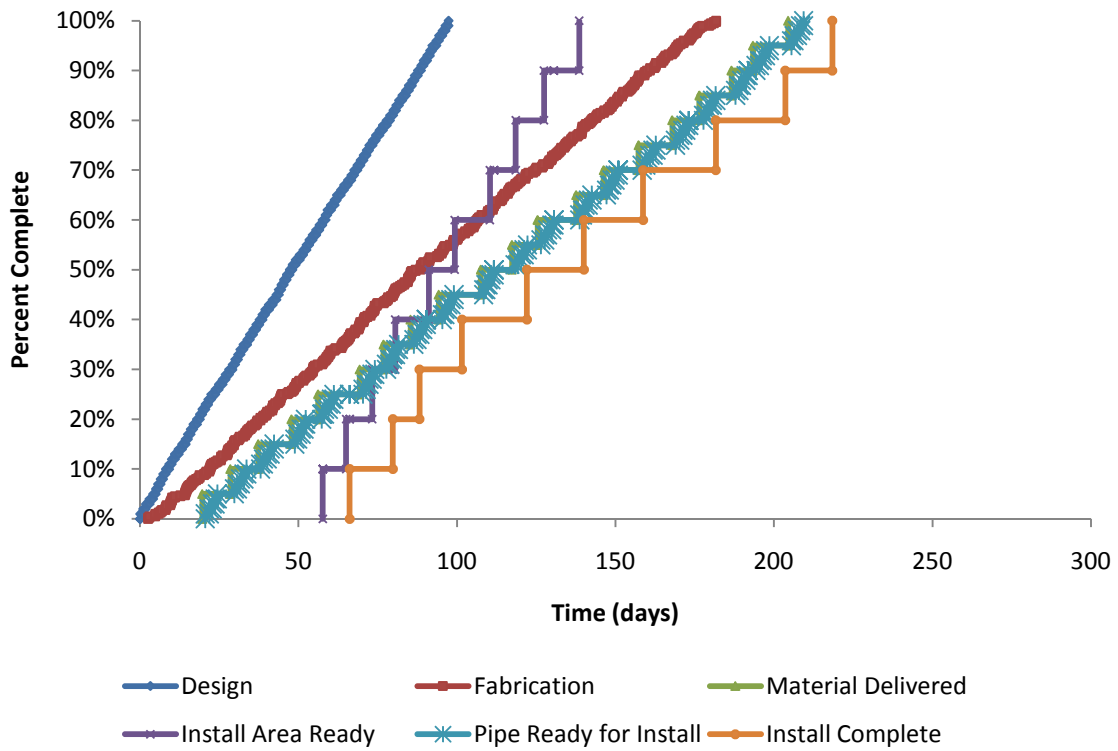

**Figure 4.14 – Percent Complete vs. Time - Work Opportunities**

allow the preparation of install areas to commence immediately after the 50 day delay period to account for site work. This activity reached 100% completion on day 139. This translates into a rate of production of 1.1 areas every 10 days. Finally, installation was able to begin on day 58 and was subsequently completed on day 219. The resulting rate of production for this activity was calculated to be 0.6 areas completed every 10 days.

#### **4.4.3 Comparison of Schedule Performance**

To compare the performance of the modified model to that of the existing model in terms of schedule, three parameters were examined for each site based activity. The parameters examined include the start and end time of each activity and the ensuing rate of production. Each activity is compared separately in the following sub-sections. This is followed by an overall discussion of the results.

##### **4.4.3.1 Comparing the Rate of Install Area Preparation**

The corresponding percent complete profiles for the install area preparation activity for both the existing and modified models from the previous sections are displayed together in Figure 4.15 below. The transparent overlays correspond to the resource allocation profiles for each instance of this activity.



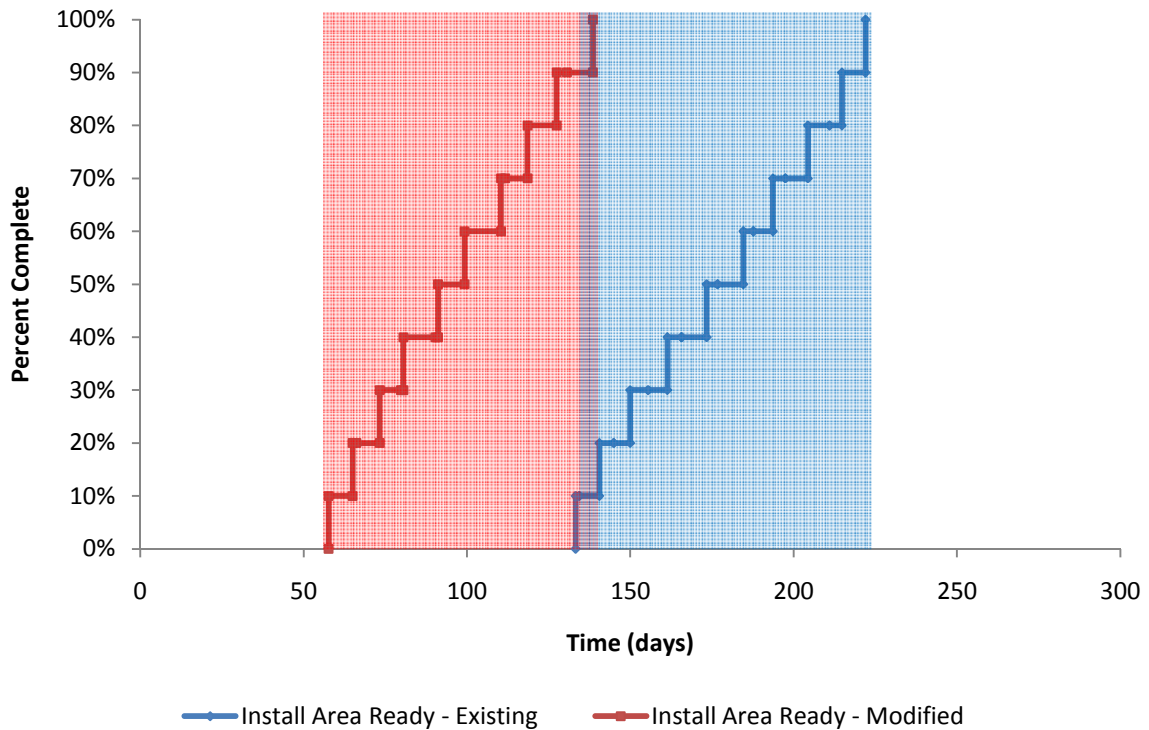

**Figure 4.15 – Comparing the Rate of Install Area Preparation**

The elimination of the material buffer and the subsequent change over to a reliance on work opportunities generated via AMLTT has the effect of moving ahead the start time of the install area preparation activity. The resulting difference between the start times is 73 days in favor of the modified model. The overall length of time to complete the preparation of all 10 install areas was also reduced from 99 to 89 days; however, this reduction can be attributed to randomness in the simulation engine and would not be expected to occur on average.

The subsequent rate of production of each instance of this activity, as reported earlier, is relatively the same. Accordingly, the resource allocation profile is the same for each case at 1 full crew for 100% of the activity duration.

#### 4.4.3.2 Comparing the Rate of Pre-Install Pipe Work

The percent complete profiles for the pre-install pipe work activity for both the existing and modified models are displayed together in Figure 4.15 below. The resource allocation profiles for each instance of this activity are overlaid in the corresponding transparent colour.

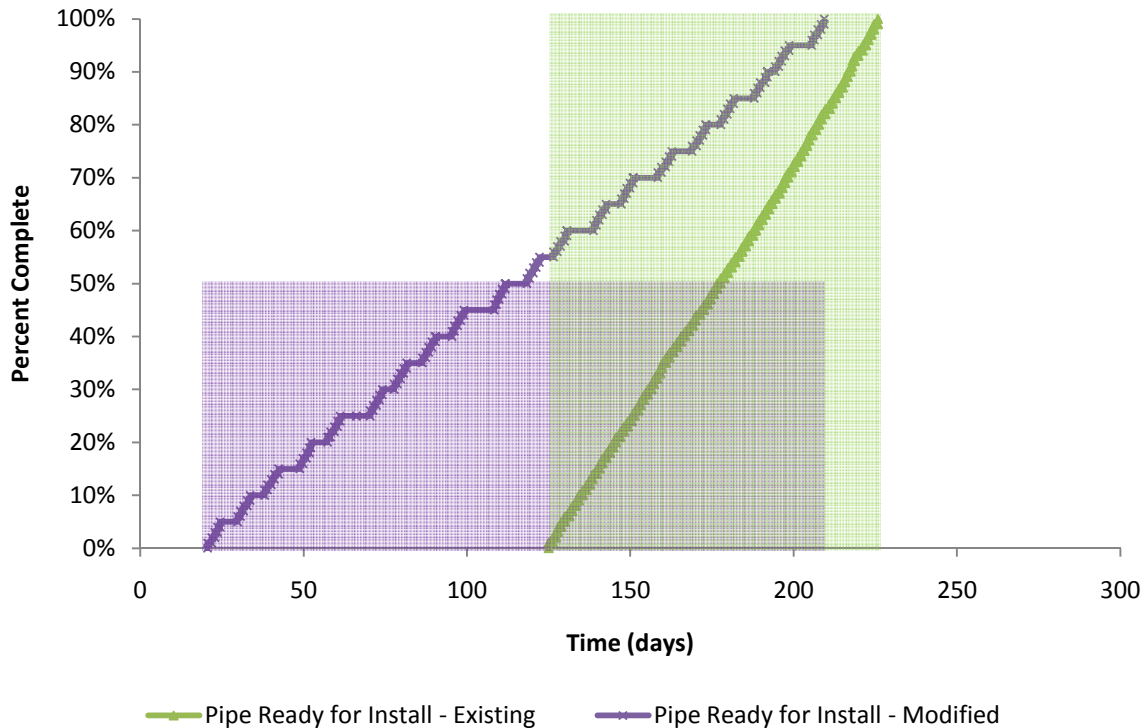

**Figure 4.16 – Comparing the Rate of Pre-Install Pipe Work**

The effect of eliminating the reliance on material buffers as a primary constraint on operations is more evident when comparing the percent complete profile for the pre-install pipe work activity for each model. In the case of the existing model the pre-install work is completed over a relatively short period of time of 102 days as previously reported. In the case of the modified model, the start time of the pre-install work is able to be pushed forward by just over 100 days. The overall duration, however, is increased by a factor of two. This is caused in part due to increased crew idle time, which is manifested in the form of disjoints in the percent complete profile for the modified model.

Accordingly, the rate of production between the existing and modified model is decreased by a factor of 2. However, this can be compensated for by reducing the crew size by a half as indicated by the corresponding resource allocation profile. While the overall activity duration is increased, most project managers should appreciate the greater flexibility that this alternative provides and improved productivity.

#### 4.4.3.3 Comparing the Rate of Installation

The percent complete profiles for the installation activity for both the existing and modified models are displayed together in Figure 4.17 below. The resource allocation profiles for each instance of this activity are overlaid in the corresponding transparent colour.

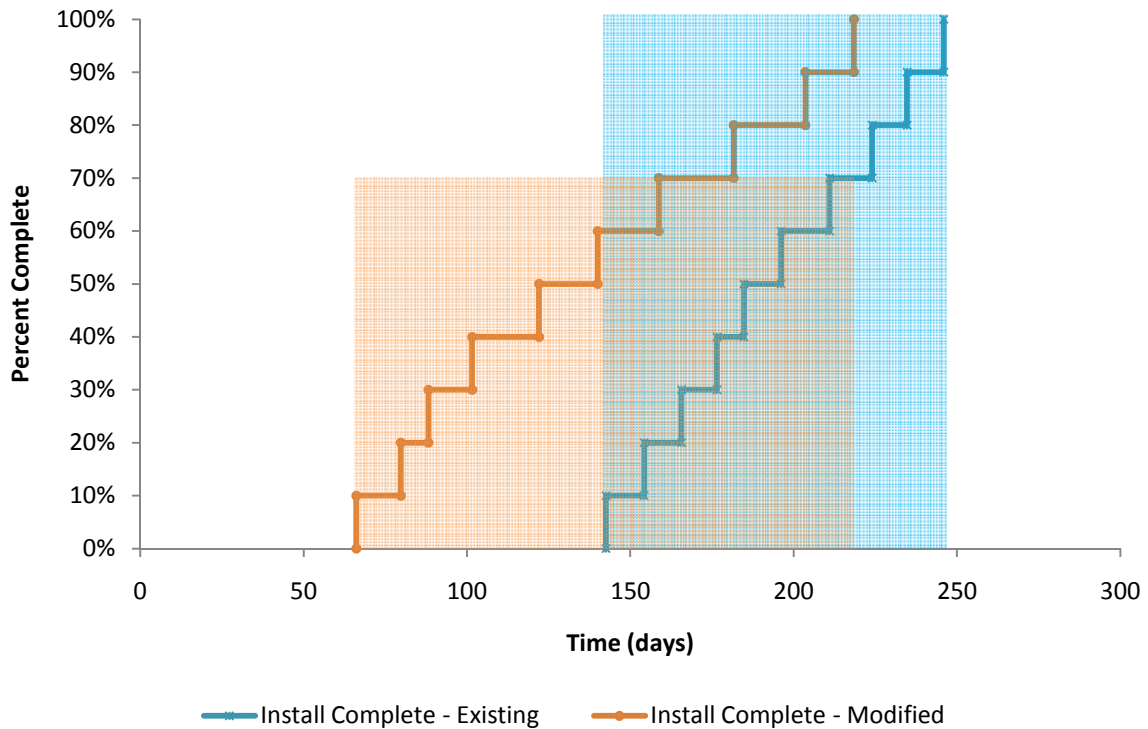

**Figure 4.17 – Comparing the Rate of Installation**

Similar differences in the percent complete profiles for the installation activity between the existing and modified models can be seen here as compared to the previous activity. The elimination of the material buffer allows for the start time of the activity to be shifted forward, in this case by 77 days. The overall activity duration under the modified model is increased by a factor of 1.4 from 115 to 161 days, which in turn decreases the overall rate of production. However, like the previous case, this can be compensated for by reducing the overall crew size by slightly less than 30%.

#### **4.4.3.4 Discussion**

Based on the completed comparison it is evident that the integration of AMLTT into the construction supply chain has the potential to improve or at least maintain construction schedule performance, while reducing the dependency on costly material stockpiles. It is recognized that under the AMLTT based model the rate of production of two thirds of the site based activities was reduced significantly and crew idle time increased. However, as was shown, this can be compensated for by reducing the applicable crew size. The ability to start work tasks earlier in the construction schedule as a result of an increased state of knowledge of the supply situation should also provide project managers with a greater flexibility to account for other unexpected events that may hinder project performance. In addition, the overall duration of the theoretical piping operation was reduced from 246 to 219 days in favor of the AMLTT based model; a reduction in schedule duration of approximately 11%. An improvement in schedule performance of even 2 to 4% would translate into significant cost savings on any typical industrial construction project. While completely hypothetical, the results presented here serve to demonstrate the beneficial impact on schedule performance that could potentially be achieved via the integration of AMLTT within a single construction supply chain such as piping, let alone the greater construction supply network as a whole.

## **Chapter 5**

### **Conclusions & Recommendations**

#### **5.1 General**

The importance of effective materials and equipment management on construction projects, especially those of a large and complex nature, cannot be ignored. The proportion of the total cost for such a project associated with material and equipment is simply too large. As a result, improving this aspect of the construction management process is readily identified as having the potential to significantly impact the performance of the project as a whole. Nonetheless, ineffective materials and equipment management remains today a leading cause of disruptions and poor performance on construction projects. A possible root cause of this is a continued reliance on methods of information collection and transfer, pertaining to the location and state of construction materials and equipment, which are predominantly human based and subsequently prone to error.

Other industry sectors, such as manufacturing and retail, have implemented new management philosophies and information based technologies into their supply networks over the last few decades. These changes have successfully improved the efficiency of their supply network operations. Attempts to introduce similar changes in the construction supply network have not been as successful. Much of the lack of success, especially from a philosophical standpoint, is a result of the overall complex and unique nature of construction projects and their associated supply chains in general. The integration of Automated Material Locating and Tracking Technologies (AMLTT) within the construction supply network, however, has shown substantial promise for improving materials and equipment management on construction projects.

The overall objective of this thesis was, therefore, to investigate the theoretical impact that AMLTT, specifically the combination of RFID and GPS, could have on the construction

management process if implemented within different segments of the construction supply network. Three specific areas of the greater construction supply network were chosen for investigation. A modeling and simulation approach was used as the primary means of investigation. As such, a number of supply network models were developed, many of which were based on either actual field trial data or experiences gained by the author using AMLTT in a construction setting. The developed models were then used to estimate the potential impact of AMLTT on the construction supply network. The conclusions recorded as part of the completed investigation are presented next.

## **5.2 Conclusions**

The conclusions drawn from the completed investigation into the impact of AMLTT on the construction supply network are presented first in terms each specific area examined. The order in which the conclusions are presented follows the same order as was maintained throughout the body of this thesis. Next, overall conclusions pertaining to the broader impact of AMLTT on construction supply network management are presented.

### **5.2.1 On-Site Material Receiving Process**

The following are the primary conclusions regarding the potential impact of AMLTT on the on-site material receiving process based on the completed investigation:

- In terms of total processing time per load, each of the five models exhibited a similar pattern when subjected to increasing truck arrival rates. In each case, a transition point was reached where the frequency of truck arrival exceeded the load processing ability of the process arrangement in question. The resulting maximum processing time for each case examined was found to vary. However, the processing time per load for those models which incorporated AMLTT in some fashion was estimated to be significantly lower than those models which did not.

- With regards to operation duration, a gradually decreasing trend was recorded for each model when subjected to increasing truck arrival rates. A transition point was found to exist for each model in this case as well. Here the transition point corresponded to when the receiving process in question became the primary constraint resulting in no further decrease in operation duration. A slower truck arrival rate at which the minimum operation duration was achieved was recorded for those models which did not incorporate AMLTT as compared to those models which did.
- Labour resource allocation was examined in terms of both the work crew and clerk where applicable. The overall trend for this parameter is the exact opposite to that of total operation duration and in each case the transition point remained the same. In all cases 100% allocation of the work crew to the material receiving process was required. The total duration results, however, are in favour of the AMLTT based models. In those models which made use of a clerk resource, his daily allocation also reaches 100% in each case. The models which assumed pre-tagged materials required less dedication of the clerk for a broader range of truck arrival rates as compared to the only model which did not assume pre-tagged materials.
- Finally, an efficiency rating was generated for each model, using the existing process model as a baseline. Overall, those models which incorporated AMLTT and assumed pre-tagged materials achieved relatively high efficiency ratings. The only model which scored a lower efficiency rating than the base case was that which assumed non-tagged materials.

## **5.2.2 Locating Material in a Construction Laydown Yard**

The following are the primary conclusions regarding the potential impact of AMLTT on the task of locating material in a construction laydown yard based on the completed risk assessment:

- A relatively high level of risk was estimated for the existing manual approach to locating material within a laydown yard. The greatest proportion of the total risk was attributed to those items which are eventually found after several search attempts or are eventually declared lost and must be reordered.
- The level of risk associated with the AMLTT based approach to locating material within a laydown yard was observed in the field and estimated by the model to be significantly lower than that of the existing process. In this case as well, the greatest proportion of risk is shared by those items which are eventually declared lost. However, due to the large proportion of items which are estimated to be located after an initial search attempt, the magnitude of risk associated with lost and unfound items is drastically reduced. In addition, the rapidness of the AMLTT approach facilitates an increased number of possible search attempts within the same or less time than can be completed using the existing manual approach. Thus, the potential opportunities to locate an item are increased.

## **5.2.3 Increasing Visibility within the Construction Supply Network**

The following are the primary conclusions regarding the proposed theory regarding the potential ability of AMLTT to increase work opportunities at the site level based on increased supply chain visibility resulting in improved schedule performance:

- In a comparison of the rate of install area preparation for the existing and modified models, the integration of AMLTT was found to have no significant impact.



However, the elimination of the material buffer constraint had the effect improving the start date of this activity in favour of the AMLTT based model arrangement.

- When considering the rate of pre-installation work, the existing process arrangement exhibited an overall greater rate of progress. This is offset, however, by the improved start date and reduction in crew allocation associated with the modified model.
- In terms of the overall rate of installation, a similar result as above was recorded. Improvement in the start time and resource allocation profile of this activity is associated with the modified model in contrast to the existing model.
- In the case of each site based activity, a reliance on on-site material buffers as a shielding mechanism was replaced by work opportunities generated by a theoretical flow of material status information via an AMLTT based system.

#### **5.2.4 Overall Conclusions**

The following are conclusions drawn regarding the potential of AMLTT to impact the overall construction supply network management process based on the completed investigation:

- The simulation results for each of the three sets of models estimated at least a marginal improvement in the process in question in favour of the models which incorporated AMLTT in some way. These results are a strong indication of the potential for AMLTT to have a beneficial impact on the construction materials management process at both the site level and within the greater supply network.
- The potential to improve resource allocation, particularly at the site level, in a number of ways through the integration of AMLTT was shown. In turn, improvements in overall process productivity could be expected.

- While a reduction in risk was only quantified for one set of models, the mitigation of risk associated with other disruptions pertaining to material location within the broader construction supply network could also be expected via the expanded implementation of AMLTT.
- Improvement in schedule performance for a single supply chain found within a greater construction supply network was estimated. The theoretical improvement was a result of increasing visibility within the supply chain under consideration using the dynamic information capabilities of AMLTT. If AMLTT were applied across an entire construction supply network, a similar result could possibly be expected.
- The simulation models themselves provide a useful understanding of the mechanics of the segments of the construction supply network under consideration. Furthermore, the modified models demonstrate how AMLTT could feasibly be integrated into those existing processes.

### **5.3 Recommendations for Future Work**

This thesis investigated the potential theoretical impact of AMLTT on only three segments of the construction supply network, with a particular focus on industrial construction projects. As such, a need to continue to examine this overall area of research remains. A number of recommendations for areas of future research and work pertaining to AMLTT and the construction industry are listed below:

- Increasing the level of awareness of the benefits of AMLTT within the construction industry membership is essential if it is to be implemented successfully on a broader scale. The continued documentation and validation of case studies centered on the application of AMLTT on actual construction projects is one means of facilitating this. RFID Journal, an online publication, regularly features ‘success stories’ pertaining to the implementation of RFID, however, almost none of these

articles are focused on construction applications. Increasing the working knowledge of the overall functionality of AMLTT at the middle management and craft level is another possible means of increasing awareness.

- Standardization of the hardware, related middleware, and software that allows AMLTT to operate is also necessary. Until this is accomplished potential adopters of this technology are likely to perceive it as too great a financial risk and will subsequently delay implementation.
- The ability of AMLTT to facilitate increased visibility within the construction supply network was only discussed in hypothetical terms within the body of this thesis. This is perceived to be an area that is in need of further examination from a research standpoint. One possible avenue to explore is the possible connection between supply chain visibility facilitated by AMLTT and work face planning.
- Many of the field trials conducted to date have either been limited to the construction workforce and surrounding area or based at a fabricator. As such, an effort should be made to facilitate and study the impact of AMLTT on an entire supply chain from the point of material or equipment origin through to the construction work face and point of final installation.
- Much of the research effort to date has focused on the application of AMLTT in the industrial construction sector. Exploring the feasibility of implementing AMLTT within other segments of the construction industry, such as residential, transportation infrastructure, and civil infrastructure are other potential research areas. Each of these sectors of the construction industry are unique in nature and as is often the case a broad stroke attempt at providing a single solution often does not work.

- Finally, investigating other uses for the material location and status information collected via an AMLTT based system should be explored. For example, how could the collected information be used in conjunction within a BIM?

**Appendix A**  
**On-Site Material Receiving Process**

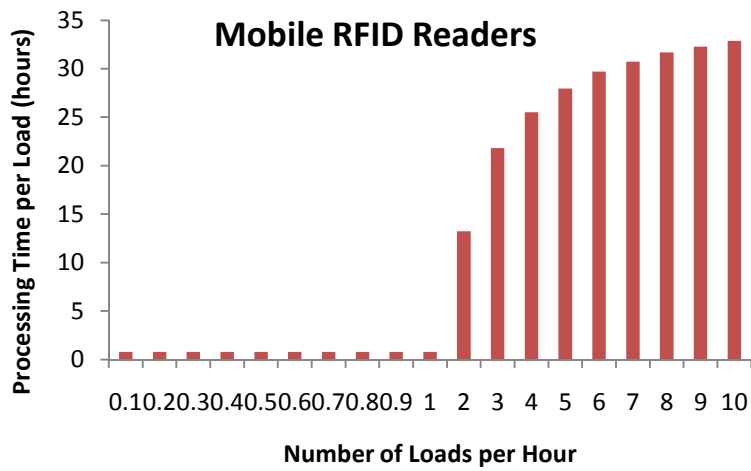
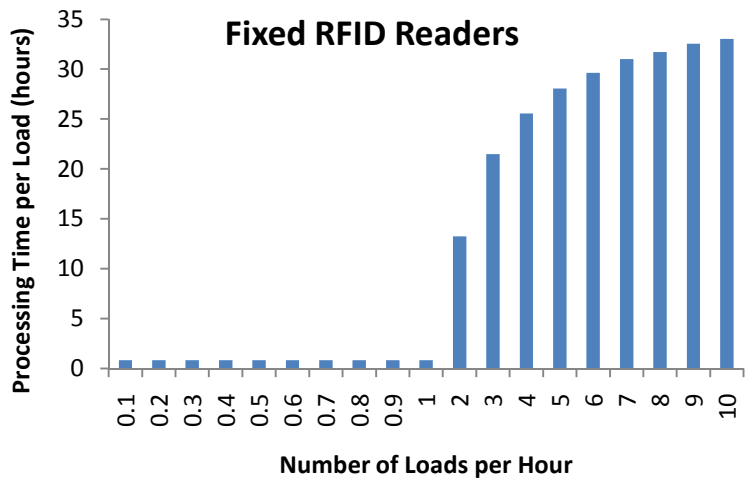
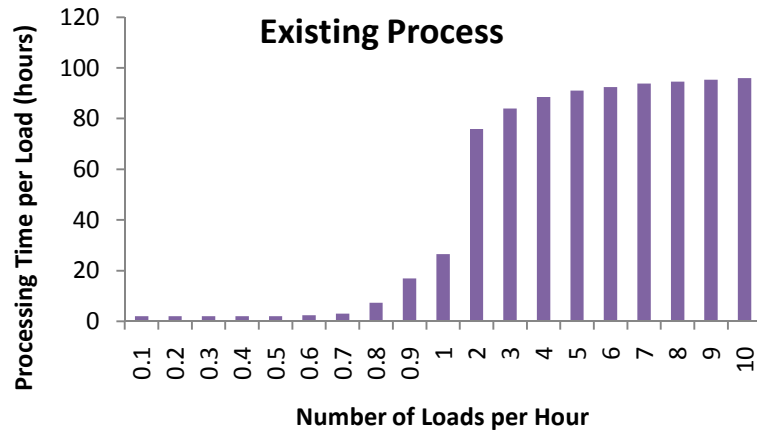

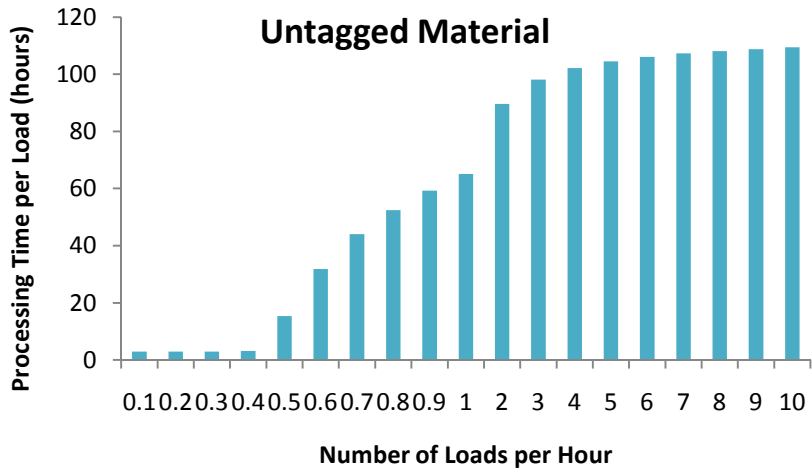
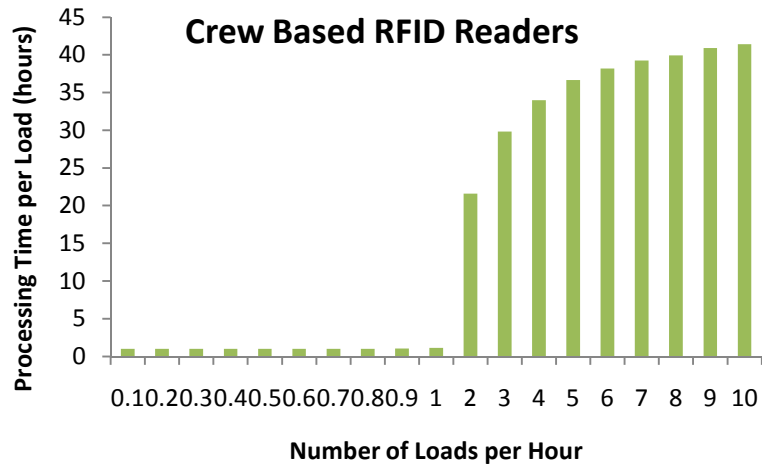

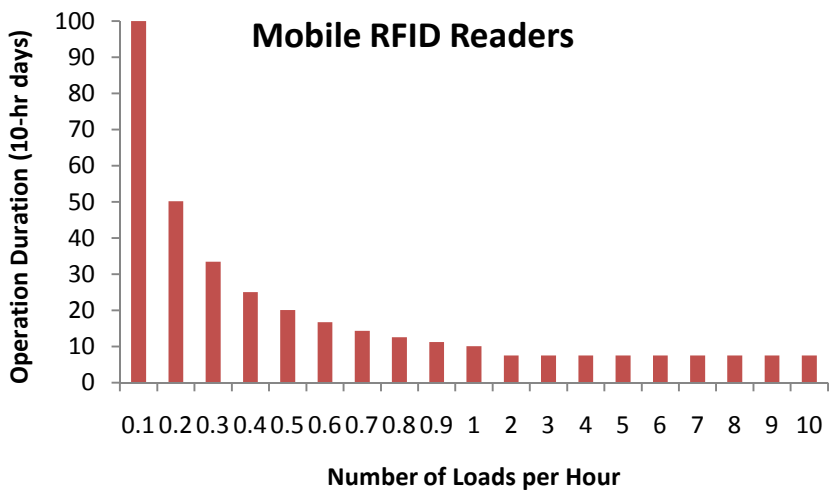
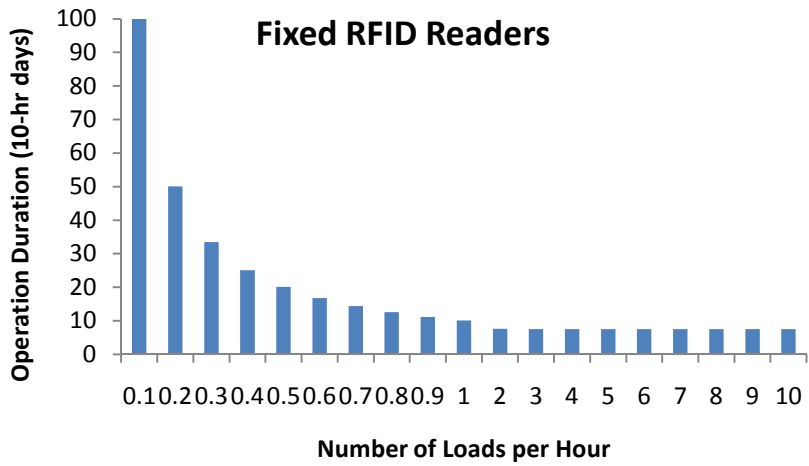
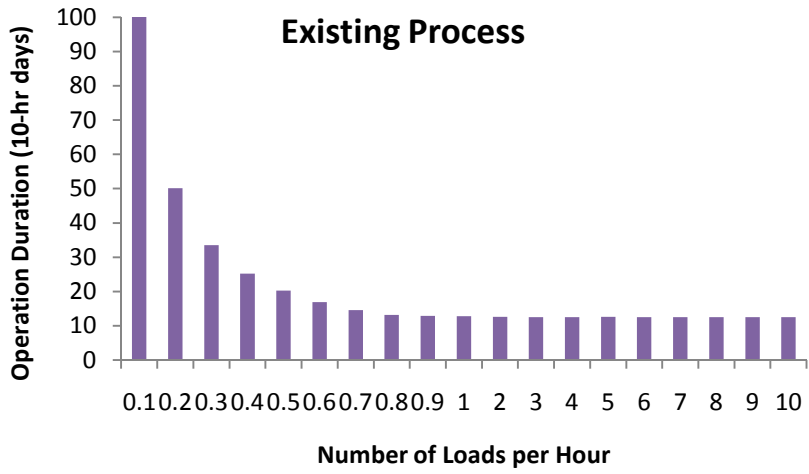



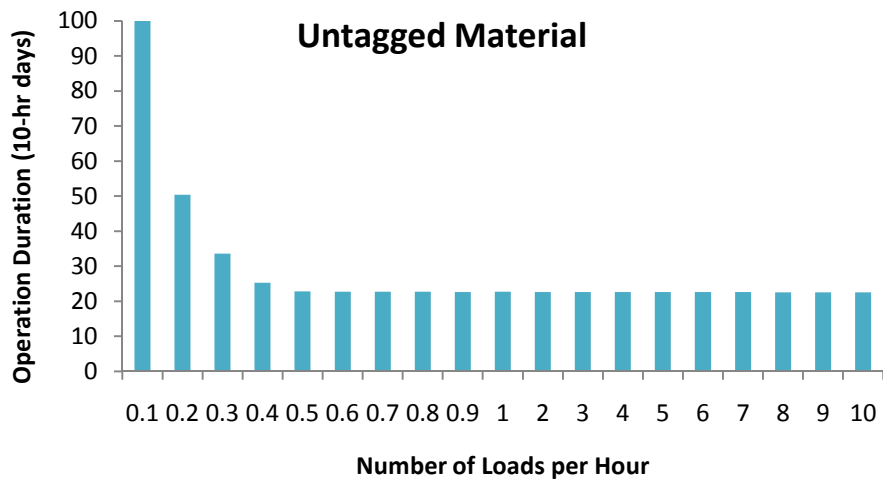
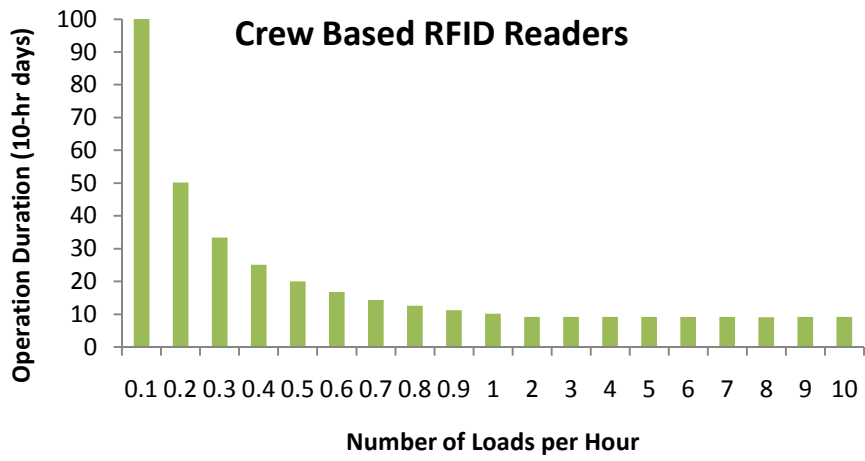

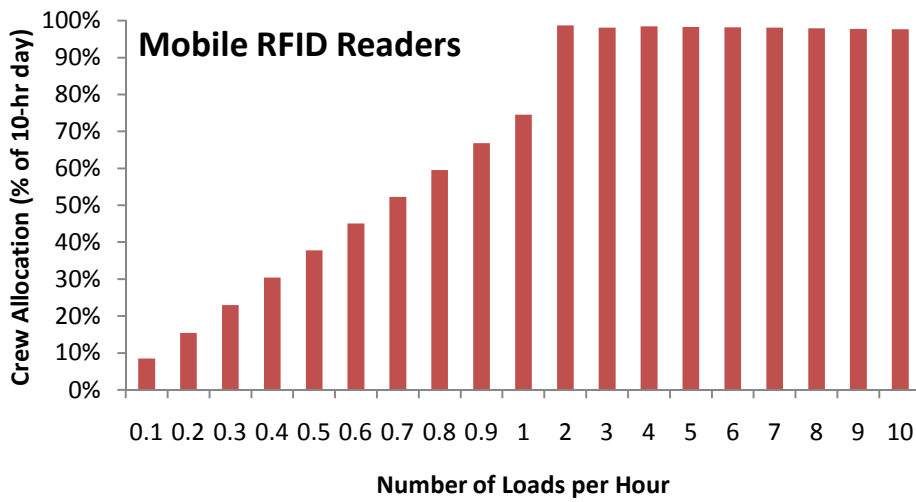
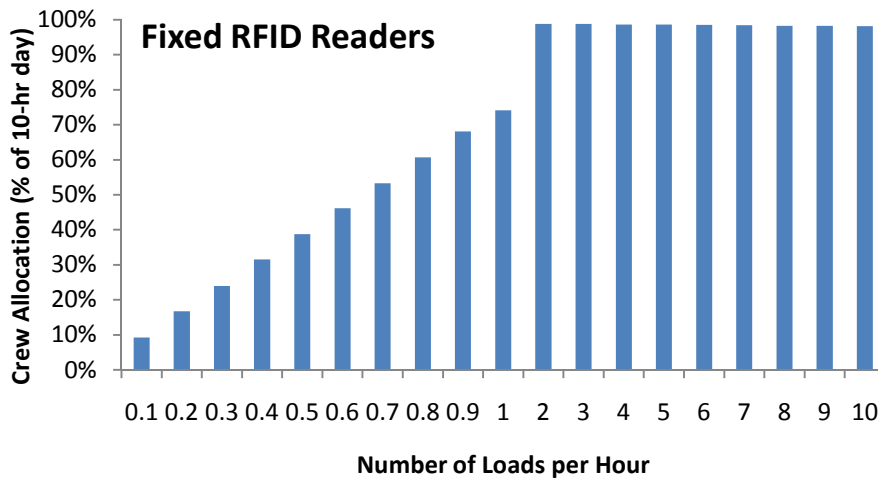
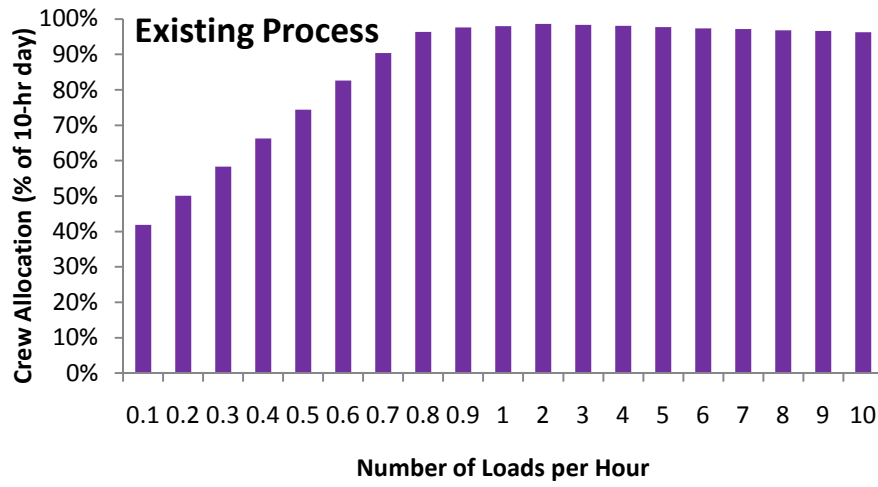

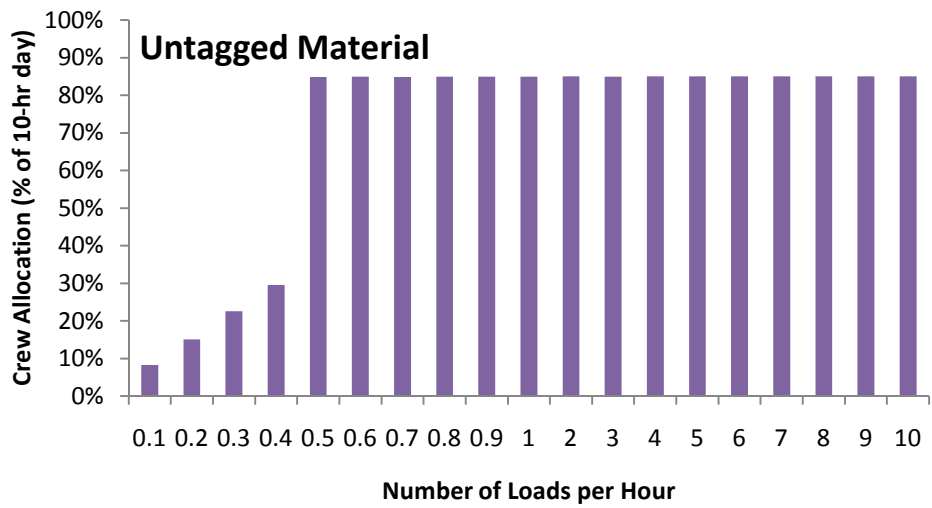
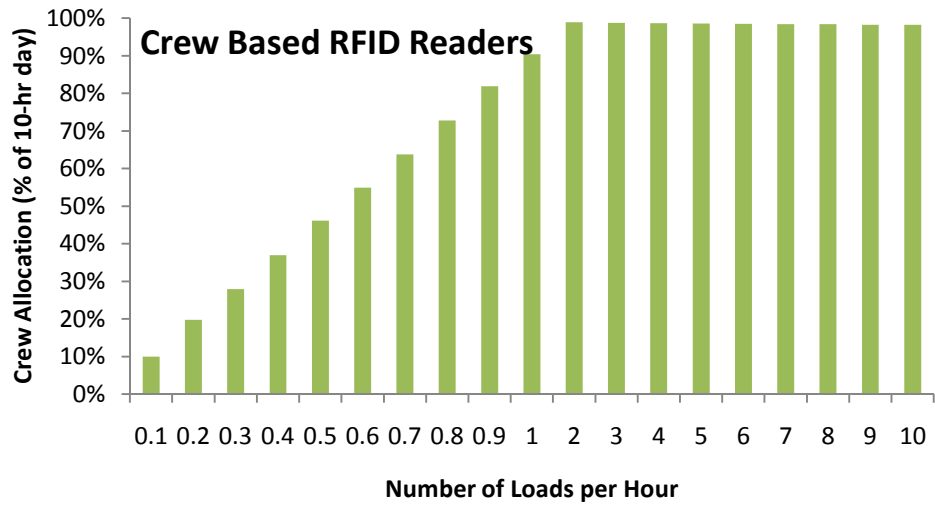

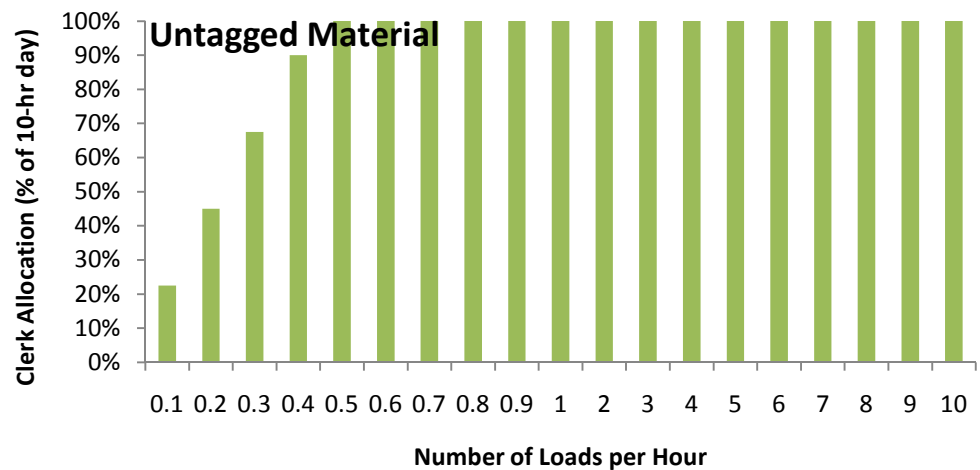
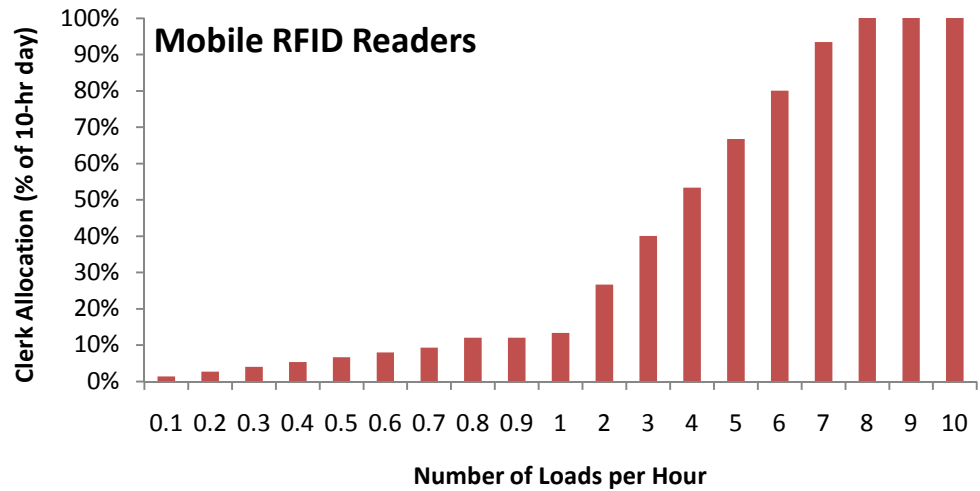
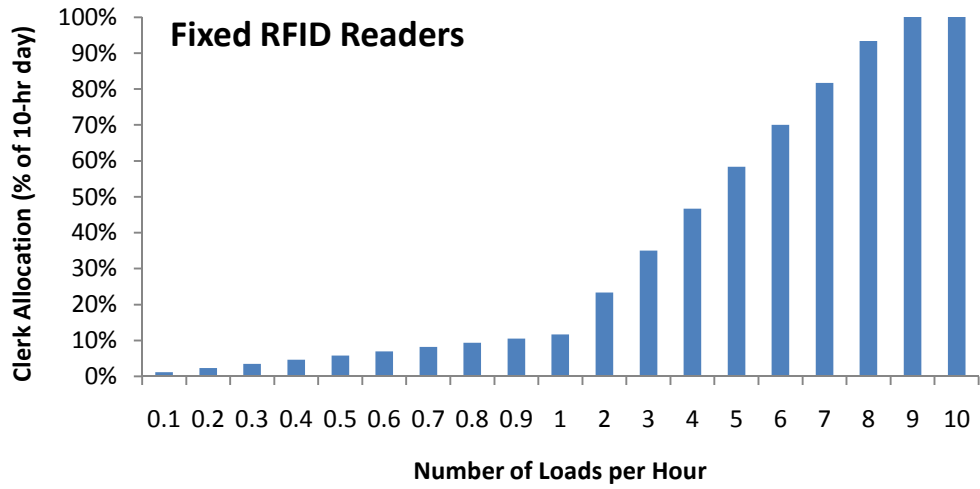

**Appendix B**  
**Increasing Visibility Within the Construction Supply Network**  
**Existing Model Results**

## 20% Install Buffer, 0% Prep Buffer

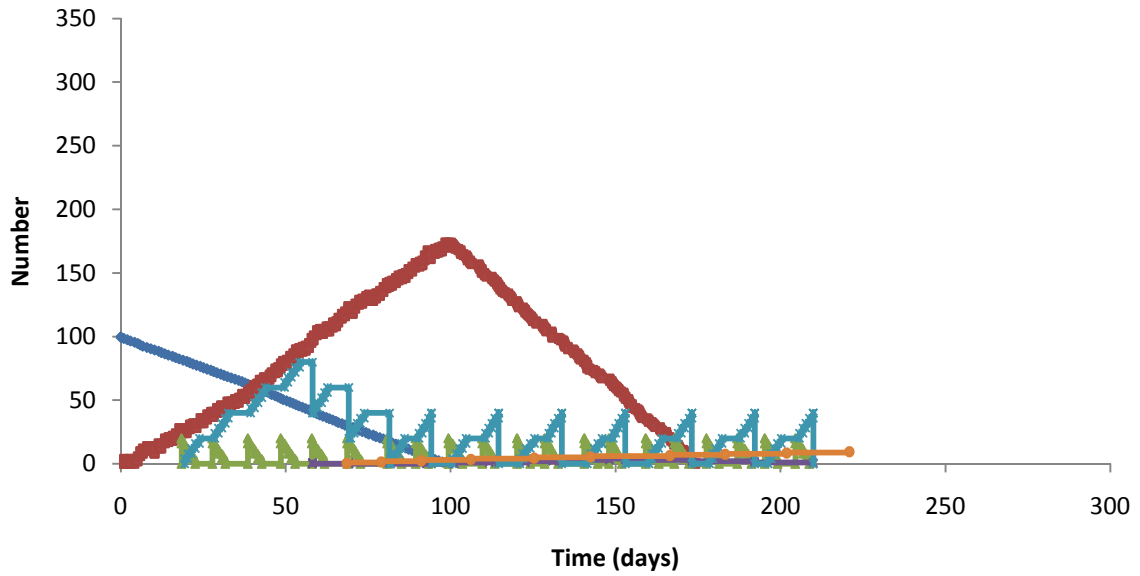

—◆— Pipe Spools to Design    
 —◆— Pipe Spools to Fabricate    
 —◆— Laydown Yard  
—◆— Install Area Ready    
 —◆— Pipe Ready for Install    
 —◆— Install Complete

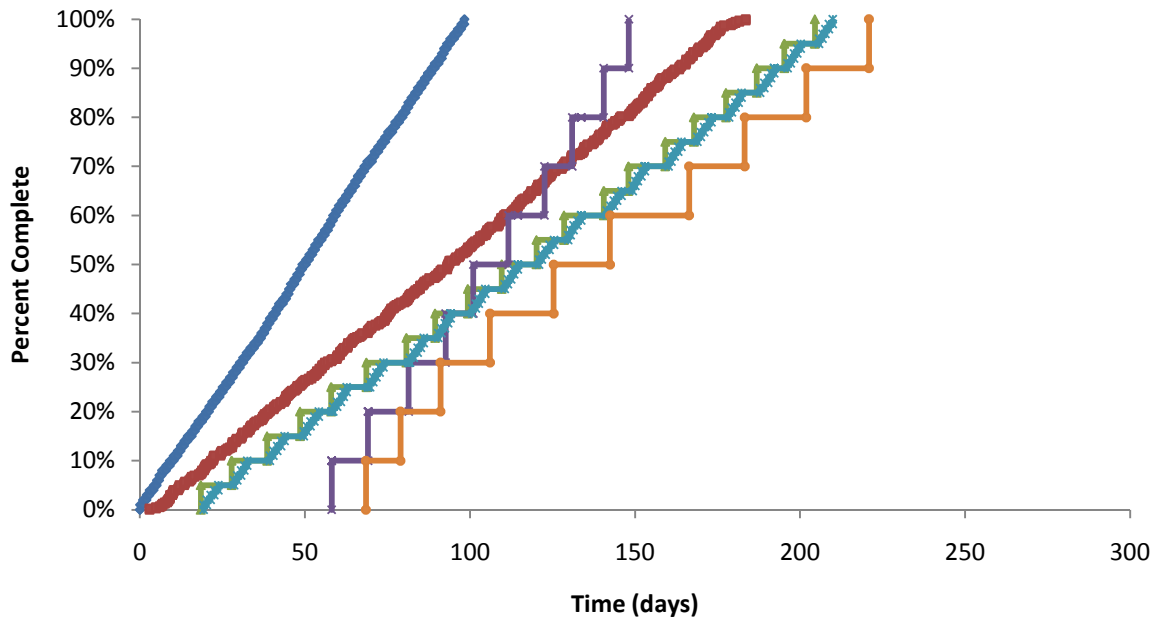

—◆— Design    
 —◆— Fabrication    
 —◆— Laydown Yard  
—◆— Install Area Ready    
 —◆— Pipe Ready for Install    
 —◆— Install Complete

### 40% Install Buffer, 20% Prep Buffer

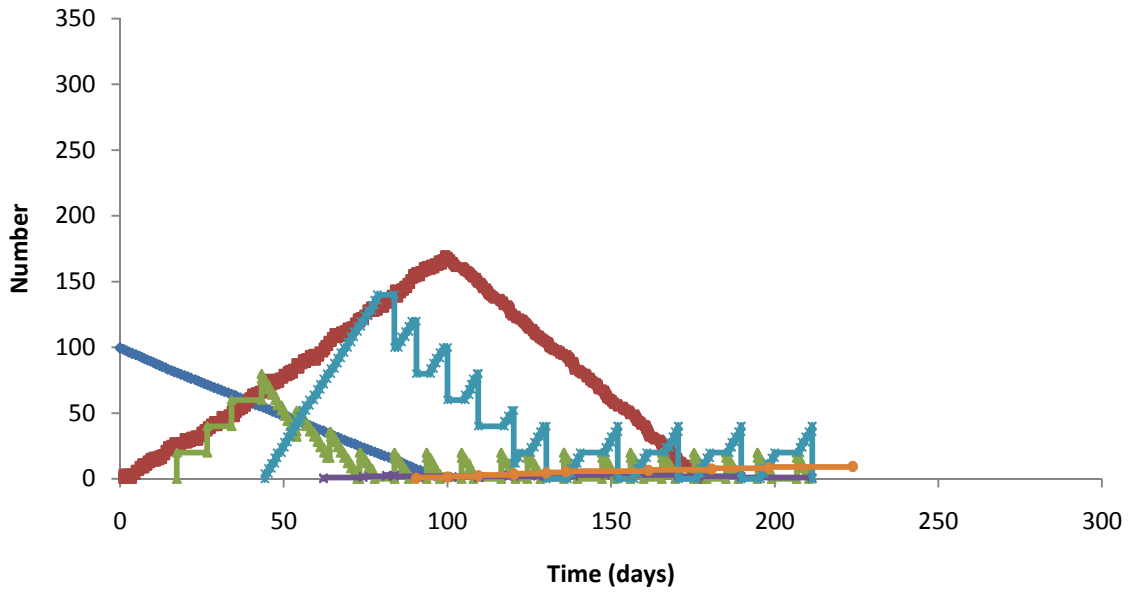

—◆— Pipe Spools to Design     —◆— Pipe Spools to Fabricate     —◆— Laydown Yard  
—◆— Install Area Ready     —◆— Pipe Ready for Install     —◆— Install Complete

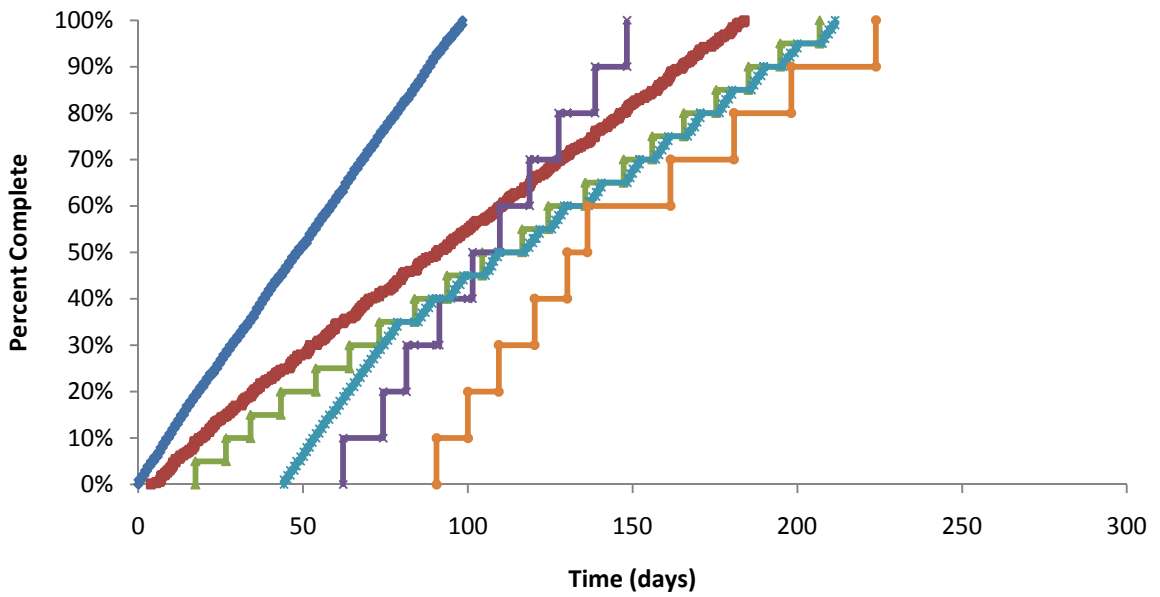

—◆— Design     —◆— Fabrication     —◆— Laydown Yard  
—◆— Install Area Ready     —◆— Pipe Ready for Install     —◆— Install Complete

### 60% Install Buffer, 40% Prep Buffer

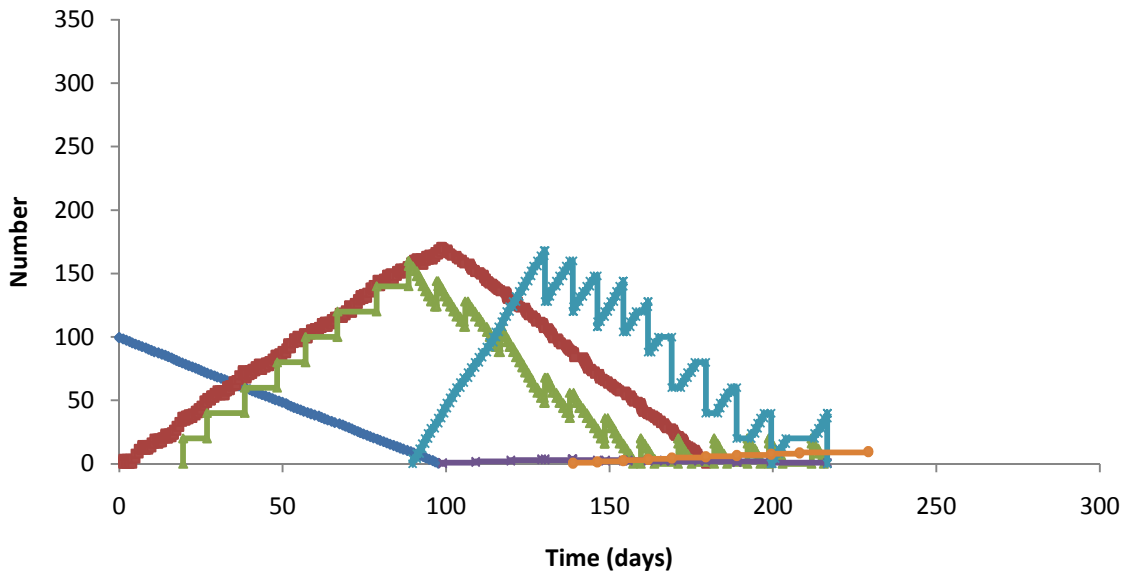

—◆— Pipe Spools to Design    
 —◆— Pipe Spools to Fabricate    
 —◆— Laydown Yard  
—◆— Install Area Ready    
 —◆— Pipe Ready for Install    
 —◆— Install Complete

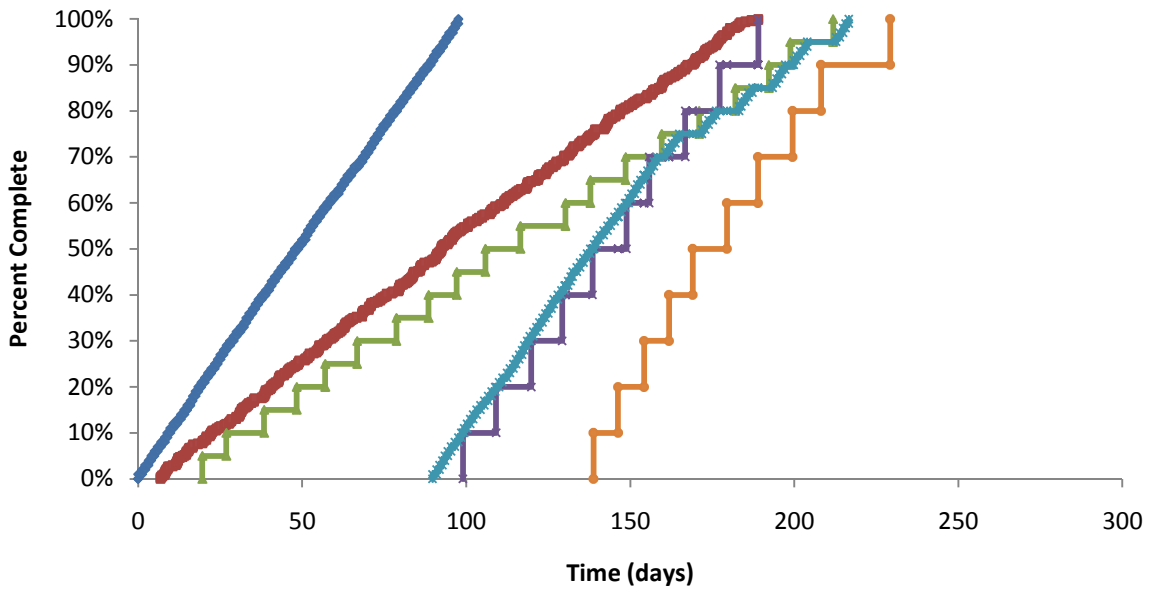

—◆— Design    
 —◆— Fabrication    
 —◆— Laydown Yard  
—◆— Install Area Ready    
 —◆— Pipe Ready for Install    
 —◆— Install Complete



### 60% Install Buffer, 55% Prep Buffer

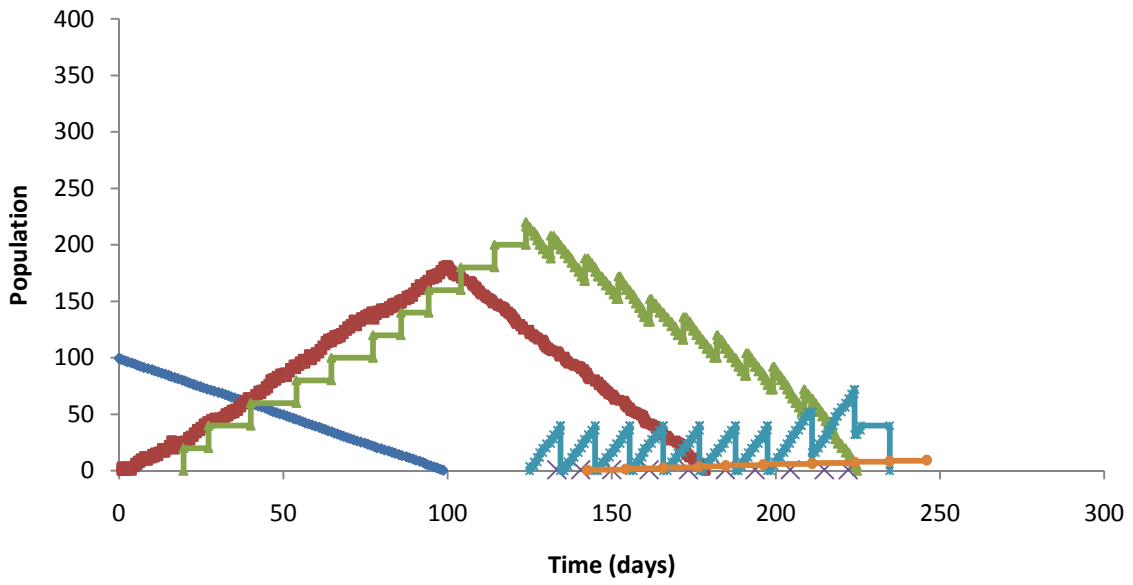

- Pipe Spools to Design      — Pipe Spools to Fabricate      — Laydown Yard
- Install Area Ready      — Pipe Ready for Install      — Install Complete

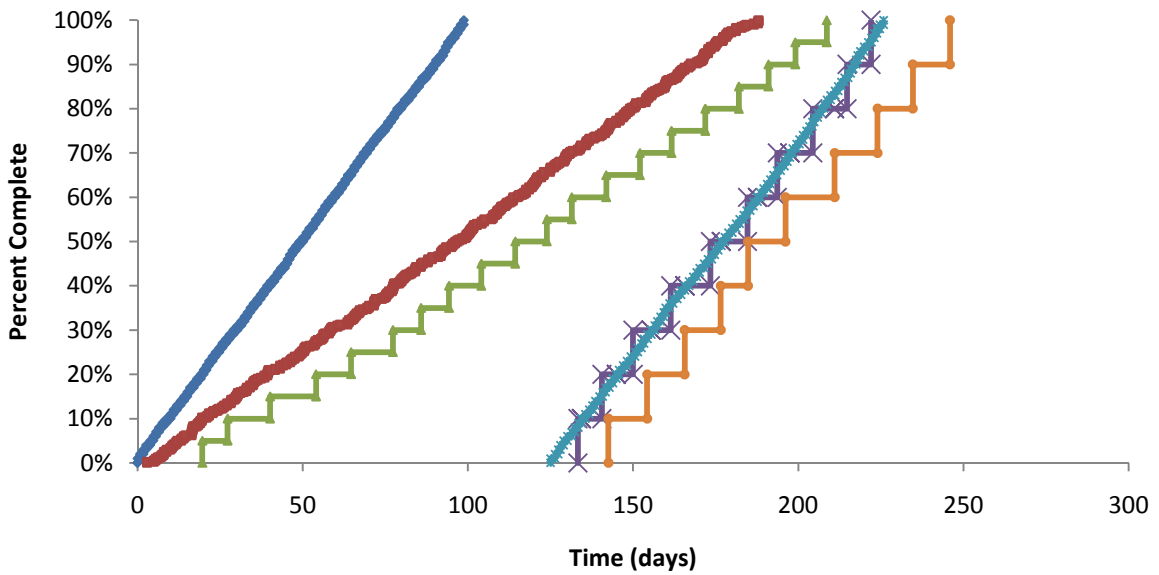

- Design      — Fabrication      — Material Delivered
- Install Area Ready      — Pipe Ready for Install      — Install Complete

### 80% Install Buffer, 60% Prep Buffer

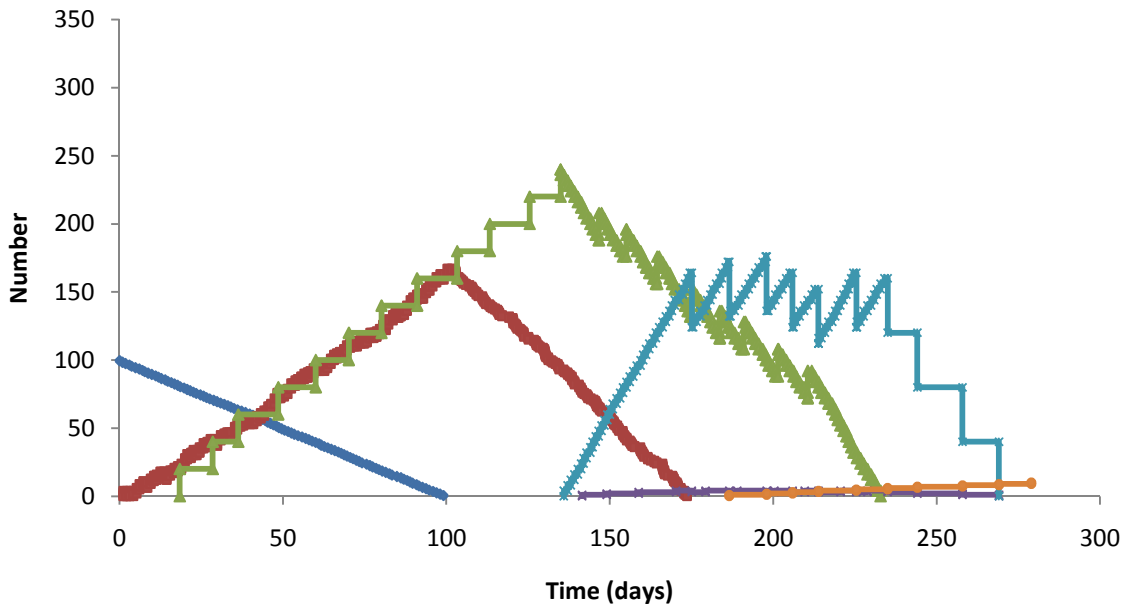

—◆— Pipe Spools to Design   
 —◆— Pipe Spools to Fabricate   
 —◆— Laydown Yard  
—◆— Install Area Ready   
 —◆— Pipe Ready for Install   
 —◆— Install Complete

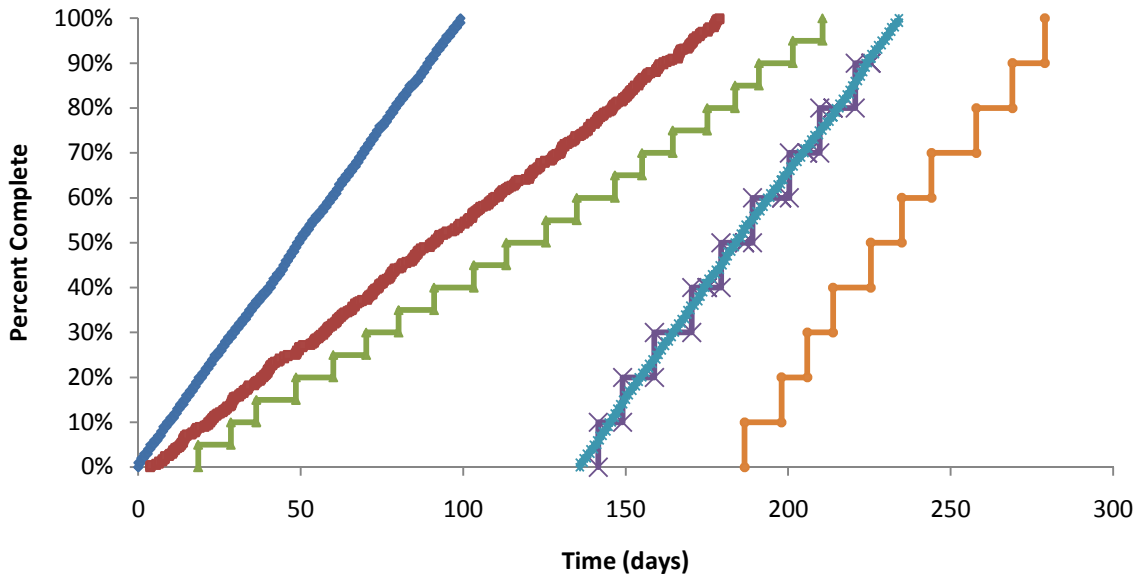

—◆— Design   
 —◆— Fabrication   
 —◆— Laydown Yard  
—◆— Install Area Ready   
 —◆— Pipe Ready for Install   
 —◆— Install Complete

### 100% Install Buffer, 80% Prep Buffer

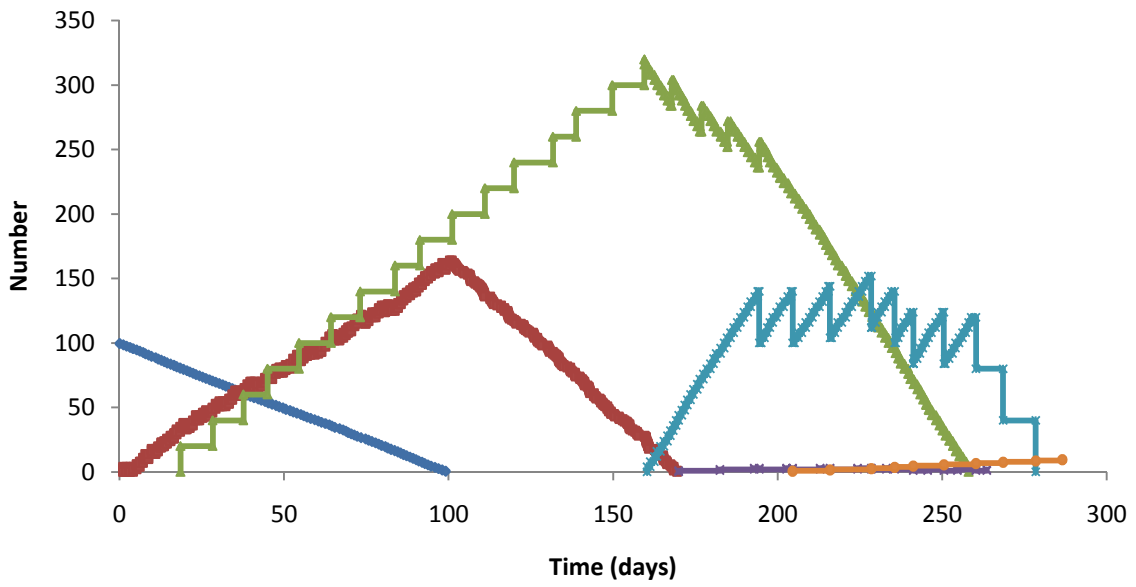

— Pipe Spools to Design   
 — Pipe Spools to Fabricate   
 — Laydown Yard  
— Install Area Ready   
 — Pipe Ready for Install   
 — Install Complete

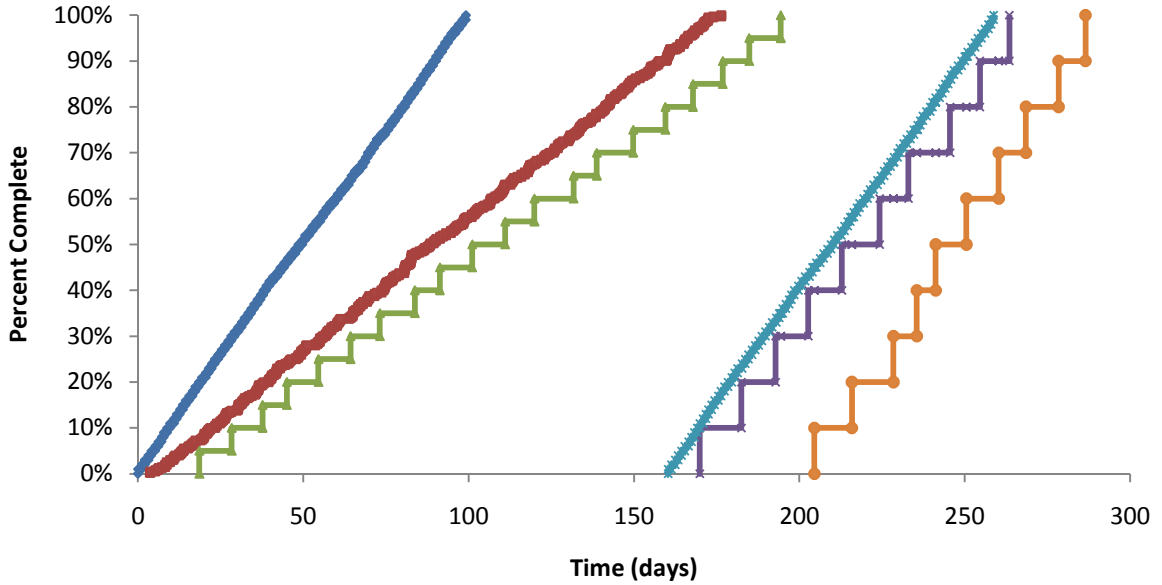

— Design   
 — Fabrication   
 — Laydown Yard  
— Install Area Ready   
 — Pipe Ready for Install   
 — Install Complete

## Bibliography

- AbouRizk, S. M., Halpin, D. W., & Lutz, J. D. (1992). State of the Art in Construction Simulation. In J. J. Swain, D. Goldsman, R. C. Crain, & J. R. Wilson (Ed.), *1992 Winter Simulation Conference*, (pp. 1271-1277). Arlington.
- Al-Sudairi, A. A., Diekmann, J. E., Songer, A. D., & Brown, H. M. (1999). Simulation of Construction Processes: Traditional Practices Versus Lean Principles. *IGLC-7* (pp. 39-50). Berkeley, CA: International Group for Lean Construction.
- Al-Sudairi, A. A., Diekmann, J. E., Songer, A. D., & H., M. B. (1999). Simulation of Construction Processes: Traditional Practices Versus Lean Principles. *IGLC-7* (pp. 39-50). Berkeley, CA: International Group for Lean Construction.
- Banks, J. (Ed.). (1998). *Handbook of Simulation: Principles, Methodology, Advances, Applications, and Practice*. New York, NY: John Wiley & Sons, Inc.
- Briscoe, G., & Dainty, A. (2005). Construction supply chain integration: an elusive goal? *Supply Chain Management* , 319-326.
- Caron, F., Razavi, S. N., Song, J., Vanheeghe, P., Duflos, E., Caldas, C., et al. (2007). Locating sensor nodes on construction projects. *Autonomous Robots* , 22 (3), 255-263.
- Chin, S., Yoon, S., Choi, C., & Cho, C. (2008). RFID+4D CAD for Progress Management of Structural Steel Works in High Rise Buildings. *Journal of Computing in Civil Engineering* , 22 (2), 74-89.
- Construction Industry Institute. (1986). *Costs and Benefits of Materials Management Systems*. The University of Texas at Austin. Austin: Construction Industry Institute.
- Construction Industry Institute. (2005). *Lean Principles in Construction*. The University of Texas at Austin. Austin: Construction Industry Institute.
- Construction Industry Institute. (1999). *Procurement and Materials Management: A Guide to Effective Project Execution*. University of Texas at Austin. Austin: Construction Industry Institute.
- Construction Industry Institute. (2008). *RT-240 Leveraging Technology to Improve Construction Productivity*. The University of Texas at Austin. Austin, Texas: Construction Industry Institute.
- Cox, A., Ireland, P., & Townsend, M. (2006). *Managing in Construction Supply Chains and Markets*. London, United Kingdom: Thomas Telford Publishing.

- Delen, D., Hardgrave, B. C., & Sharda, R. (2007). RFID for Better Supply-Chain Management through Enhanced Information Visibility. *Productions and Operations Management* , 16 (5), 613-624.
- Diekmann, J. E., Krewedl, M., Balonick, J., Stewart, T., & Won, S. (2004). *Application of Lean Manufacturing Principles to Construction*. University of Colorado at Boulder. Austin: Construction Industry Institute.
- Ergen, E., Akinci, B., & Sacks, R. (2007). Life-cycle data management of engineered-to-order components using RFID. *Avandced Engineering Informatics* , 21, 356-366.
- Ergen, E., Akinci, B., & Sacks, R. (2007). Tracking and locating components in a precast storage yard utilizing radio frequency identification technology and GPS. *Automation in Construction* , 16 (3), 354-367.
- Glover, B., & Bhatt, H. (2006). *RFID Essentials*. Sebastopol, CA, U.S.A.: O'Reilly Media Inc.
- Goodrum, P. M., McLaren, M. A., & Durfee, A. (2006). The application of active radio frequency technology for tool tracking on construction job sites. *Automation in Construction* , 15 (3), 292-302.
- Halpin, D. W., & Kueckmann, M. (2002). Lean Construction and Simulation. In E. Yucesan, C. -H. Chen, J. L. Snowdon, & J. M. Charnes (Ed.), *2002 Winter Simulation Conference*, (pp. 1697-1703). San Diego.
- Halpin, D. W., & Martinez, L. H. (1999). Real World Applications of Construction Process Simulation. In H. B. Farrington, D. T. Nembhard, D. T. Sturrock, & G. W. Evans (Ed.), *1999 Winter Simulation Conference*, (pp. 956-962). Phoenix.
- Halpin, D. W., & Riggs, L. S. (1992). *Planning and Analysis of Construction Operations*. New York, NY, United States: John Wiley & Sons, Inc.
- Harland, C. M. (1996). Supply Chain Management: Relationships, Chains & Networks. *British Journal of Management* , 7, 63-80.
- Hedgepeth, W. O. (2007). *RFID Metrics: Decision Making Tools for Today's Supply Chains*. Boca Raton, FL, U.S.A.: Taylor & Francis Group.
- Hofmann-Wellenhof, B., Lichtenegger, H., & Collins, J. (2001). *GPS: Theory and Practice* (5th Edition ed.). New York, NY, U.S.A.: Springer-Verlag/Wien.
- Howell, G. A., & Ballard, H. G. (1996). *RR 47-13 Managing Uncertainty in the Piping Function*. The University of Texas at Austin. Austin, Texas: Construction Industry Institute.

- Howell, G. A., & Ballard, H. G. (1999). What is Lean Construction? *Conference of the International Group for Lean Construction*. Berkley: International Group for Lean Construction.
- Jaselskis, E. F., Anderson, M. R., Jahren, C. T., Rodriguez, Y., & Njos, S. (1995). Radio-Frequency Identification Applications in Construction Industry. *Journal of Construction Engineering and Management* , 121 (2), 189-196.
- Jaselskis, E. J., & El-Misalami, T. (2003). Implementing Radio Frequency Identification in the Construction Process. *Journal of Construction Engineering and Management* , 129 (6), 680-688.
- Kaplan, E. D. (Ed.). (1996). *Understanding GPS Principles and Applications*. Boston, MA, U.S.A: Artech House.
- Kini, D. (1999). Materials Management: The Key to Successful Project Management. *Journal of Management in Engineering* , 30-34.
- Koskela, L. (1992). *Application of the New Production Philosophy to Construction*. Stanford: Stanford University.
- Lamming, R. (1996). Squaring Lean Supply with Supply Chain Management. *International Journal of Operations and Production Management* , 16 (2), 183-196.
- Lehpamer, H. (2008). *RFID Design Principles*. Norwood, MA, U.S.A.: Artech House.
- Logsdon, T. (1995). *Understand the NAVSTAR: GPS, GIS, and IVHS* (2nd Edition ed.). New York, NY, U.S.A.: Van Nostrand Reinhold.
- London, K., Kenley, R., & Agapiou, A. (1998). Theoretical Supply Chain Network Modelling in the Building Industry. *14th Annual Association of Research in Construction Management* (pp. 369-379). Reading, United Kingdom: University of Reading.
- Martinez, J. C. (2001). EZStrobe - General-Purpose Simulation System Based on Activity Cycle Diagrams. In B. A. Peters, J. S. Smith, D. J. Medeiros, & M. W. Rohrer (Ed.), *2001 Winter Simulation Conference*, (pp. 1556-1564). Arlington.
- Martinez, J. C. (1996). STROBOSCOPE - State and Resource Based Simulation of Construction Processes. Doctoral Dissertation. Ann Arbor, Michigan, United States: Department of Civil and Environmental Engineering, University of Michigan.

- Marzouk, M., & Moselhi, O. (2003). Object-oriented Simulation Model for Earthmoving Operations. *Journal of Construction Engineering and Management* , 129 (2), 173-181.
- Myerson, J. M. (2007). *RFID in the Supply Chain*. Boca Raton, FL, U.S.A.: Taylor & Francis Group.
- Nasir, H. (2008). A Model for Automated Construction Materials Tracking. Master of Applied Science Thesis. Waterloo, Ontario: Department of Civil & Environmental Engineering, University of Waterloo.
- Navon, R. (2007). Research in automated measurement of project performance indicators. *Automation in Construction* , 16 (2), 176-188.
- O'Brien, W. J. (1997). Construction Supply-Chains: Case Study, integrated cost and performance analysis. In L. Alarcon (Ed.), *Lean Construction* (pp. 187-222). Rotterdam, The Netherlands: A.A. Balkema.
- O'Brien, W. J., London, K., & Vrijhoef, R. (2002). Construction Supply Chain Modeling: A Research Review and Interdisciplinary Research Agenda. *Conference of the International Group for Lean Construction* (pp. 129-148). Gramado, Brazil: International Group for Lean Construction.
- Plemmons, J. K., & Bell, L. C. (1995). Measuring Effectiveness of Materials Management Process. *Journal of Management in Engineering* , 11, 26-32.
- Razavi, S. N., Young, D. A., Nasir, H., Haas, C. T., Caldas, C., Goodrum, P., et al. (2008). Field Trial of Automated Material Tracking in Construction. *CSCE 2008 Annual Conference*. Quebec City.
- Ruwanpura, J. Y., AbouRizk, S. M., Er, K. C., & Fernando, S. (2001). Special purpose simulation templates for tunnel construction operations. *Canadian Journal of Civil Engineering* , 28, 222-237.
- Salem, O., Salomon, J., Genaidy, A., & Minkarah, I. (2006). Lean Construction: From Theory to Implementation. *Journal of Management in Engineering* , 22 (4), 168-175.
- Sawhney, A., AbouRizk, S. M., & Halpin, D. W. (1998). Construction project simulation using CYCLONE. *Canadian Journal of Civil Engineering* , 25, 16-25.
- Sawhney, A., Mund, A., & Marble, J. (1999). Simulation of the Structural Steel Erection Process. In P. A. Farrington, H. B. Nembhard, D. T. Sturrock, & G. W. Evans (Ed.), *1999 Winter Simulation Conference*, (pp. 943-947). Phoenix.

- Shepard, S. (2005). *RFID: Radio Frequency Identification*. New York, NY, U.S.A.: McGraw-Hill.
- Silver, E. (1988). Materials Management in Large-Scale Construction Projects: Some Concerns & Research Issues. *Engineering Costs and Production Economics* , 15, 223-229.
- Song, J., Haas, C. T., & Caldas, C. (2006). Tracking the Location of Materials on Construction Job Sites. *Journal of Construction Engineering and Management* , 132 (9), 911-918.
- Song, J., Haas, C. T., Caldas, C., Ergen, E., & Akinici, B. (2006). Automating the task of tracking the delivery and receipt of fabricated pipe spools in industrial projects. *Automation in Construction* , 15 (2), 166-177.
- Tah, J. H. (2005). Toward an agent-based construction supply network modelling and simulation platform. *Automation in Construction* , 14, 353-359.
- Thomas, H. R., Riley, D. R., & Messner, J. I. (2005). Fundamental Principles of Site Material Management. *Journal of Construction Engineering and Management* , 131 (7), 808-815.
- Tommelein, I. D. (1998). Pull-Driven Scheduling for Pipe Spool Installation: Simulation of Lean Construction Technique. *Journal of Construction Engineering and Management* , 124 (4), 279-288.
- Torrent, D. G., & Caldas, C. H. (2007). Field Experiments of an Automated Materials Identification and Localization Model. In L. Soibelman, & B. Akinici (Ed.), *ASCE International Workshop on Computing in Civil Engineering* (pp. 689-696). Pittsburgh: ASCE.
- Vrijhoef, R., & Koskela, L. (2000). The Four Roles of Supply Chain Management in Construction. *European Journal of Purchasing & Supply Management* , 6, 169-178.
- Wickramatillake, C. D., Lenny Koh, S. C., Gunasekaran, A., & Arunachalam, S. (2007). Measuring Performance within the Supply Chain of a Large Scale Project. *Supply Chain Management* , 12 (1), 52-59.