

**The North House
as Component Based Architecture**

by
Chloe Ruth McLeod Doesburg

A thesis
presented to the University of Waterloo
in fulfillment of the
thesis requirement for the degree of
Master of Architecture

Waterloo, Ontario, Canada, 2010
© Chloe Ruth McLeod Doesburg 2010

Author's Declaration

I hereby declare that I am the sole author of this thesis. This is a true copy of the thesis, including any required final revisions, as accepted by my examiners.

I understand that my thesis may be made electronically available to the public.

ABSTRACT

The North House is a proof-of-concept prefabricated solar-powered home designed for northern climates, and intended for the research and promotion of high-performance sustainable architecture. Led by faculty at the University of Waterloo, the development and design of the project involved a broad collaboration between faculty and students at the University of Waterloo, with Ryerson University and Simon Fraser University. The North House prototype competed in the U.S. Department of Energy's Solar Decathlon in October of 2009.

This thesis identifies the North House as a component-based building. It illustrates in detail the components of which the house is composed, the sequence by which they are assembled, and the details that allow for the building's rapid assembly and disassembly.

Finally, the thesis explores the possibilities afforded by component-based architecture including adaptability, off-site fabrication and demountability. Drawing on this, the thesis projects future ways of designing buildings sustainable to both manufacture and operate.

ACKNOWLEDGEMENTS

I would like to thank my supervisor Geoffrey Thün, and the members of my committee David Lieberman and Kathy Velikov for providing me with the opportunity to work on this project, for their assistance in the production of this document, and for their continued support throughout.

I would also like to thank Jack Debski whose ingenuity and dedication made this project possible.

Lastly, I would like to thank the entire North House team whose combined effort not only produced this project, but also a created a wonderful environment in which to share and learn.

For a full list of team members please see the extended acknowledgements (appendix B).

DEDICATION

I would like to dedicate this to the student members of the North House Architectural team with whom I have worked closely for the last year and a half: Lauren Barhydt, Chris Black, Maun Demchenko, Natalie Jackson, Jen Janzen and Bradley Paddock who have provided me with tremendous support and friendship over the course of the project.

I would also like to dedicate this to Duncan, and to thank him for all of his help, love and support.

TABLE OF CONTENTS

iii	Author's Declaration	62	
v	Abstract	66	Step 11 - Fascia Cladding Supports
vii	Acknowledgements	70	Step 12 - Exterior Blinds
ix	Dedication	74	Step 13 - BIPV Cladding Panels
xiii	List of Illustrations	78	Step 14 - Solar Panels & Solar Thermal Collectors
		80	Step 15 - North Wall
		82	Step 16 - Interiors
1	INTRODUCTION		Step 17 - Exterior Landscape
3	A Brief Introduction to the North House		
4	Design Objectives	85	NORTH HOUSE ON DISPLAY
7	Introducing the Solar Decathlon		
8	Exhibition Houses	93	DISASSEMBLY
10	The North House as a Component-Based Building	99	CONCLUSION
12	Situating the Thesis	100	Reflection / Projection
		—	Adaptability
15	ASSEMBLY	101	Off-Site Fabrication
16	Summary of Components	102	Demountability
20	Exploded Axonometric	105	Extended Producer Responsibility
22	Step 1 - Site Survey & Prep	—	The Design of Manufacture
24	Step 2 - The Densepack		
28	Step 3 - Floor Panels	107	NOTES
32	Step 4 - Roof Panels & Columns		
38	Step 5 - Roof Racking	113	BIBLIOGRAPHY
42	Step 6 - Mullion Frames		
46	Step 7 - Base Support Frame	121	APPENDICES
50	Step 8 - IGUs & Mullion Caps	121	Appendix A: Selected As-Built Drawings
54	Step 9 - Aluminum Closer Panels	140	Appendix B: Extended Acknowledgements
58	Step 10 - Exterior Blind Supports		

LIST OF ILLUSTRATIONS

	INTRODUCTION		
1.1	North House floor plan - by Team North	2.2.2	drawing by author
1.2	“a house for climate extremes” diagram - by Dave Schellingerhoudt and Lindsey Nette, courtesy of Team North	2.2.3	drawing by author
		2.2.4	photograph by Andrea Hunniford
		2.2.5	drawing by author
1.3	“Distributed Responsive Systems of Skins” diagram - by Dave Schellingerhoudt and Lindsey Nette, courtesy of Team North	2.2.6	drawing by author
		2.2.7	drawing by author
		2.2.8	drawing by author
1.4	“adaptive living interface system” diagram - by Johnny Rodgers and Kevin Muise, courtesy of Team North	2.3.1	drawing by author
		2.3.2	drawing by author
		2.3.3	drawing by author
1.5	“holistic solar living” diagram - by Dave Schellingerhoudt and Lindsey Nette, courtesy of Team North	2.3.4	photograph by Andrea Hunniford
		2.3.5	drawing by author
		2.3.6	drawing by author
1.6	“customizable components” diagram - by RVTR, courtesy of Team North	2.3.7	photograph by Jamie Usas
		2.4.1	drawing by author
1.7	photograph from U.S. Solar Decathlon website, http://www.solardecathlon.org (accessed 10.02.10)	2.4.2	drawing by author
		2.4.3	drawing by author
		2.4.4	drawing by author
1.8	diagram by author	2.4.5	photograph by Andrea Hunniford
		2.4.6	photograph by Andrea Hunniford
		2.4.7	drawing by author
	ASSEMBLY	2.4.8	drawing by author
2.0.1	drawing by author	2.4.9	drawing by author
2.0.2	drawing by author	2.4.10	drawing by author
2.0.3	drawing by author	2.4.11	drawing by author
2.1.1	drawing by author	2.4.12	drawing by author
2.1.2	drawing by author	2.4.13	photograph by Andrea Hunniford
2.1.3	drawing by author	2.4.14	photograph by Andrea Hunniford
2.1.4	photograph by Andrea Hunniford	2.5.1	drawing by author
2.1.5	drawing by author	2.5.2	drawing by author
2.2.1	photograph by Andrea Hunniford	2.5.3	drawing by author

2.5.4	drawing by author	2.10.5	drawing by author
2.5.5	drawing by author	2.11.1	photograph by Andrea Hunniford
2.5.6	photograph by Andrea Hunniford	2.11.2	drawing by author
2.5.7	photograph by Andrea Hunniford	2.11.3	drawing by author
2.6.1	photograph by Andrea Hunniford	2.11.4	drawing by author
2.6.2	drawing by author	2.11.5	drawing by author
2.6.3	drawing by author	2.12.1	photograph by Andrea Hunniford
2.6.4	drawing by author	2.12.2	drawing by author
2.6.5	drawing by author	2.12.3	drawing by author
2.6.6	drawing by author	2.12.4	photograph by Andrea Hunniford
2.6.7	drawing by author	2.12.5	drawing by author
2.6.8	drawing by author	2.12.6	drawing by author
2.6.9	drawing by author	2.12.7	drawing by author
2.6.10	photograph by Andrea Hunniford	2.12.8	drawing by author
2.7.1	drawing by author	2.12.9	drawing by author
2.7.2	drawing by author	2.13.1	photograph by Andrea Hunniford
2.7.3	drawing by author	2.13.2	drawing by author
2.7.4	drawing by author	2.13.3	drawing by author
2.7.5	drawing by author	2.13.4	photograph by Andrea Hunniford
2.7.6	photograph by Andrea Hunniford	2.13.5	drawing by author
2.8.1	photograph by Jamie Usas	2.13.6	drawing by author
2.8.2	drawing by author	2.13.7	photograph by Andrea Hunniford
2.8.3	drawing by author	2.14.1	drawing by author
2.8.4	drawing by author	2.14.2	drawing by author
2.8.5	drawing by author	2.14.3	photograph by Andrea Hunniford
2.8.6	drawing by author	2.14.4	drawing by author
2.8.7	drawing by author	2.14.5	drawing by author
2.8.8	drawing by author	2.14.6	drawing by author
2.8.9	drawing by author	2.14.7	photograph by Andrea Hunniford
2.9.1	photograph by Andrea Hunniford	2.15.1	drawing by author
2.9.2	drawing by author	2.15.2	drawing by author
2.9.3	drawing by author	2.16.1	drawing by author
2.9.4	photograph by Andrea Hunniford	2.16.2	drawing by author
2.9.5	drawing by author	2.17.1	drawing by author
2.9.6	drawing by author	2.17.2	drawing by author
2.10.1	photograph by Andrea Hunniford		
2.10.2	drawing by author		
2.10.3	drawing by author		
2.10.4	drawing by author		

NORTH HOUSE ON DISPLAY

- 3.1 photograph by Andrea Hunniford
- 3.2 photograph by Geoff Thun
- 3.3 photograph by Geoff Thun
- 3.4 photograph by Geoff Thun
- 3.5 photograph by Andrea Hunniford
- 3.6 photograph by Geoff Thun
- 3.7 photograph by Geoff Thun
- 3.8 photograph by Geoff Thun
- 3.9 photograph by Andrea Hunniford
- 3.10 photograph by Geoff Thun
- 3.11 photograph by Andrea Hunniford
- 3.12 photograph by Geoff Thun, courtesy of Team North

DISASSEMBLY

- 4.1 photographs by Jamie Usus, composite by author
- 4.2 diagram composite by author

INTRODUCTION

A BRIEF INTRODUCTION TO THE NORTH HOUSE

The North House is a proof-of-concept, prefabricated, solar-powered home designed for northern climates, developed as part of a research project initiated in Fall 2007 and led by Professors Geoffrey Thün and Kathy Velikov at the University of Waterloo School of Architecture. The development and design of the project involved a broad collaboration between faculty and students at the University of Waterloo, with Ryerson University and Simon Fraser University. This thesis originates from this faculty-directed research project for which I was a primary member of the graduate student team. Many of the concepts and details described in this work were developed by the team in the greater context of the project, however the production of the descriptive illustrations of the assembly sequence, and the prioritization of the implications of a design for disassembly approach to the detailing of North House are unique contributions that I have made to the larger project team.

With a focus on high-performance architecture, responsive systems and interactive technologies, the house was designed for use as a public demonstration project, where it could showcase a wide range of new applications of technology and promote an energy conscious lifestyle. It was also intended for use as a research laboratory, for the long-term monitoring of its systems, and to house subsequent iterations of these systems and components. The house was fabricated by MCM 2001 Inc., a custom millwork and components manufacturer located in Toronto, Ontario. During fabrication Professor David Lieberman played a key role in project refinement and completion.

North House was one of twenty projects selected as finalists to compete in the 2009 Solar Decathlon, sponsored by the United States Department of Energy (DOE) and the National Renewable Energy Laboratory (NREL). The houses of all twenty finalists were erected on the National Mall in Washington D.C. during the month of October 2009, where they competed against one another in ten contests structured to both qualitatively and quantitatively assess their design and performance. North House placed fourth overall in the competition.

The house is organized into two basic zones. The first is a highly insulated north service zone, called the densepack, which constitutes the building's primary structural module and contains almost all of the mechanical and electrical components, wet services and storage. The second zone is an open flexible and reconfigurable living and sleeping space, clad on three sides in the DReSS layered façade system which partners large areas of glazing with responsive exterior shading.

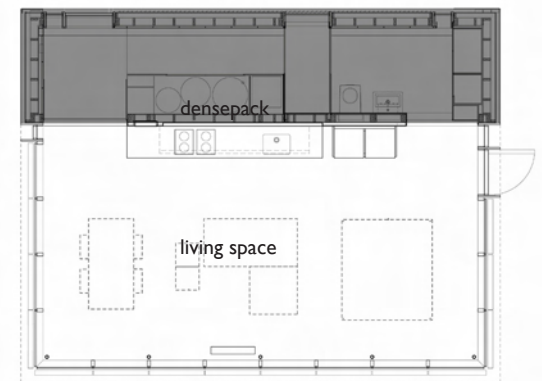


fig 1.1 - floor plan

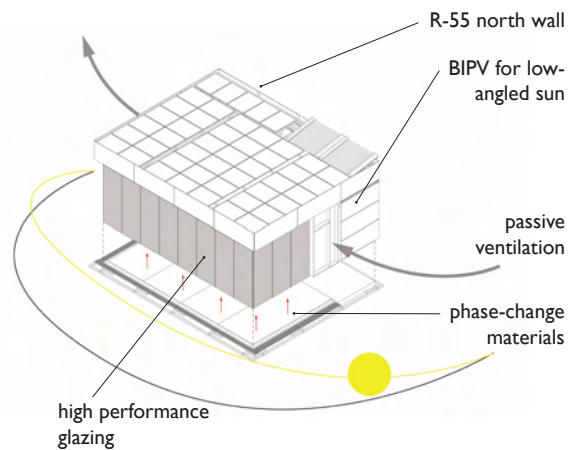


fig 1.2 - a house for climate extremes



fig 1.3 - distributed responsive system of skins

DESIGN OBJECTIVES

Five design objectives were established by the team at the outset of the North House project and remained consistent throughout the 18-month design and construction process. These objectives are outlined here along with their manifestation in the built project:

A House for Climate Extremes

Beyond meeting the design challenges of a cold climate, North House is designed to perform in an extreme climate with broad fluctuations, such as that of Southern Ontario, where it is common to experience hot, humid summers, and cold, dry winters, ranging between $+30^{\circ}\text{C}$ and -15°C .¹ The house is designed to respond quickly to these fluctuations using a layered façade system called DReSS, outlined below.

The power generating elements of the house are intended to perform in a variety of conditions. While horizontally oriented photovoltaic panels located on the project's roof perform optimally in the summer, vertically mounted building integrated photovoltaic panels on solar-exposed façades allow for power production in winter when sun angles are low. These panels combined comprise a 14kW solar array which over the course of an annual cycle, and when grid tied, is designed to produce almost twice the energy that the house consumes. Solar thermal collectors on the roof provide hot water for both domestic use, and space conditioning through a three tank cascading heat system. Operable insulated ventilation panels provide passive cross ventilation in the spring and fall seasons, while maintaining the integrity of the thermal envelope when in the closed position.

DReSS (Distributed Responsive System of Skins)

DReSS is a layered system of building skins in which each layer performs a specific function. The overall system is intended to constitute an envelope that responds dynamically to changes in exterior environmental conditions, the interior state of the home, and the desires of its occupants. The ratio of solid insulated wall assembly to DReSS was carefully balanced using energy modeling software to maximize the capacity for passive heating, while providing adequate insulation to retain that heat. The layers of the system include: automated exterior Venetian blinds, high performance glazing in a custom designed wood mullion system, and motorized interior shades. The system combines active and passive technologies in order to be both energy efficient and highly responsive.

The exterior Venetian blinds are used to block solar radiation before it reaches the glazing and begins to heat the building's interior. When passive heating is desired they can be fully retracted to maximize solar gains. Between these two extreme operational states, the blinds are capable of subtle variations to mediate solar exposure and create a multitude of fine-grained configurations. Salt hydrate, an encapsulated phase change material (PCM) in the floor allows for both ambient capture and diurnal heat storage. The control system for the blinds was developed by the project team to outperform existing manufacturer controls which operate at fixed predetermined states based on typical weather patterns for a given geographic location. Rather, solar and wind sensors track the sun's actual performance in real time, so that façades are only shaded as required, leaving ample glazing exposed for daylight and views to the exterior.

The insulated glazing units (IGUs) were selected for their R-value, solar heat gain coefficient and visual transmittance. The IGUs manufactured by Serious Materials have an R-value of 12, a solar heat gain coefficient of 0.438 and visual transmittance of 0.585. They have semi-insulating spacers which balance insulative and structural capacity, allowing for the manufacture of large, high-performance units. Large IGUs combined with the design of the wood mullion system minimizes the “frame effect”, in which heat is lost primarily through the edges of the IGUs. Three low emissivity (low e) coatings are located on surfaces facing the exterior to control radiant heat. Units are comprised of a quad-layer system, with two mylar films suspended between two panes of glass, the interior cavities of which are krypton filled. The glazing system attempts to use materials and detail configurations to achieve the highest system R-value. In order to do this, it incorporates rubber caps anchored to friction-fit clips pre-installed on the face of the mullion. Due to time constraints the friction-fit clip was manufactured in steel for the prototype, but can be replaced with a non-conductive material such as fibreglass or high-density plastic.

The interior shades can be individually controlled to provide privacy and reduce glare. They allow the occupant to control her environment in a way that will not compromise the critical performance of the building envelope.

ALIS (Adaptive Living Interface System)

The Adaptive Living Interface System is a digital interface through which occupants can control the active systems within the North House. Three touch screens within the house allow for the intuitive control of lights, shades and the interior climate through a set of gradient-based switches. The interface provides direct feedback in terms of how selected settings affect performance, energy consumption, energy cost, etc. These same controls can also be accessed online or through a smart phone, providing maximum flexibility to the occupants.

Another feature of the ALIS system is the ‘ambient canvas,’ an LED display embedded in the kitchen backsplash informing occupants of their energy and water consumption, as well as their progress with regard to predetermined goals. This ambient feedback is of a more abstract nature, and is based on psychological research examining occupant behavior suggesting that subconscious, non-information based cues form a critical dimension to shaping behavior, in this case, domestic behavior and the development of ‘sustainable practices’ through non-information based reinforcement.² Providing residents with cues about the building’s function is key to their involvement in its efficient operation. This kind of subtle feedback display, combined with the building’s smart controls, gives residents a sense of agency which will help to foster their commitment to sustainable living.



fig 1.4 - adaptive living interface system



fig 1.5 - holistic solar living

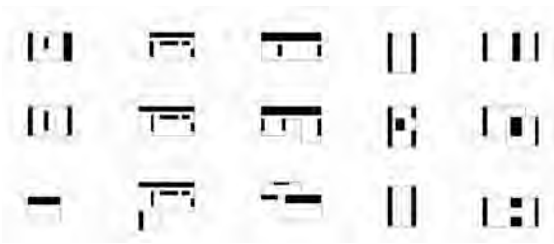


fig 1.6 - customizable components

Holistic Solar Living

Holistic solar living incorporates the sun's energy in ways much broader than just photovoltaic power generation. Many aspects of the design of the North House encourage its residents to embrace seasonal extremes. The functioning of the house, notably the DReSS façade system, responds to climatic variation in a way that characterizes the interior space of the home, encouraging a lifestyle that varies with the seasons. Daylighting and visual connections to the outdoors are maximized especially in colder months when residents tend to spend less time outdoors. In warmer months, the residents of the North House can enjoy a range of outdoor amenities, including a very generous deck, with space for dining and entertaining, vegetable gardens for food production, and an extensive outdoor counter with a sink, for canning or drying food grown on site. All of these factors encourage the residents of the North house to live a lifestyle in tune with solar and seasonal conditions.

Customizable Components

The North House is a prefabricated, factory-built housing prototype, which is comprised of independent components. The project was designed anticipating the potential for mass production and mass customization, insofar as its constituent elements might be reconfigured to produce a range of housing types, and sizes. Although the house is capable of being used in its prototype state to support two occupants, this is not intended to declare an optimal final design solution, but rather, a prototype for the components, systems, and approaches that would inform a broader set of designed products for market. The prototype house is comprised of a series of independent components that allow the house to be assembled and disassembled with ease, and for individual components or entire systems to be swapped out and replaced by alternates. This possibility was explored through the *Latitude Housing System*³ developed by RVTR in parallel with the North House. The component-based design of the North House allows it to function as a laboratory for testing alternate systems as they are developed. The components, systems, and approaches of the North House can also be applied to a wider range of building projects. For example the DReSS system, tested on the North House prototype could be used in buildings of various scales and programs.

While these five objectives were maintained throughout the duration of the design process, they were not the only parameters that shaped the project. Since the house was to participate in the 2009 Solar Decathlon it also needed to be designed for a range of exigencies linked to the rules, regulations, and conditions of the DOE's competition, and the specific limitations of construction on the National Mall in Washington D.C., including at a broad level, transit constraints, ease and rapidity of assembly and disassembly, limited structural loading to the ground condition, and the logics of limited staging areas during on site work.

INTRODUCING THE SOLAR DECATHLON

The Solar Decathlon is a biannual competition hosted by the United States Department of Energy and the National Renewable Energy Laboratory. From a range of applicants' proposals, the DOE selects 20 finalists. These teams build their solar-powered house in the months leading up to the competition, and then transport it in pieces to Washington D.C. where they reassemble it over a period of seven days on the National Mall. The objectives of the competition* did not specifically include developing prefabricated building techniques, but due to these particular competition constraints, was something that all teams needed to consider. Prefabricated building technique was a specific focus for our team, but the competition added additional constraints which would influence the design of the North House.

It is not a straightforward task to determine which strategies of the North House were exclusively geared to the competition, as from its conception the rules of the competition were a conceptual and logistic set of constraints against which other ambitions were layered. Certain parameters of the competition did however have significant impact on the design of the house.

The most significant of these constraints was temporal – the teams were only allotted seven days for on-site construction, inspection and balancing, and only three days for disassembly, with work able to occur 24 hours a day during these periods. Further tightening the timeline was the stipulation that teams were to grid-tie their power generation system on the fifth day of construction, after which time power consumed for construction activities (power tools) would be limited by the amount of power the house could generate. If a team consumed energy in excess of their production, that specific energy draw would be deducted from the total energy produced by the house during the competition as a form of performance penalty.⁴

The second most significant constraint imposed by the Solar Decathlon competition came from the limitations and logistics of transportation between Toronto, Ontario, and Washington DC. Eight trucks in total would transport the North House project, three “roll-tite” retractable tarpaulin 53-foot trailers would carry components for the exterior landscape, and five trucks, including an extendable double drop trailer, two 53-foot dry vans, and two “roll-tite” retractable tarpaulin 53-foot trailers, would bring elements comprising the house. Components were packed, and trucking sequences scheduled to ensure their arrival in the order that they were required during the assembly of the house. The extent of the build site was limited to 82x67-feet and the plan dimensions of the assembled project, including the exterior landscape was 70x57-feet, leaving a very limited staging area for the maneuvering of equipment, materials and crew during the construction period. In addition, 19 other teams would be constructing their houses simultaneously, on adjacent sites.

Based on the construction time-frame, trucking logistics, and space constraints, the team sought to design for maximum speed and ease of assembly and disassembly without compromising any of the other goals of the project. Finding the strategy that would achieve this became one of the most significant challenges of the design.

* Goals of the Solar Decathlon:

1. *To educate the student participants—the “decathletes”—about the benefits of energy efficiency, renewable energy and green building technologies. As the next generation of engineers, architects, builders, and communicators, the decathletes will be able to use this knowledge in their studies and their future careers.*
2. *To raise awareness among the general public about renewable energy and energy efficiency and how solar energy technologies can reduce energy use.*
3. *To help solar energy technologies enter the marketplace faster. This competition encourages the research and development of energy-efficiency and energy production technologies.*
4. *To foster collaboration among students from different academic disciplines—including engineering and architecture students, who rarely work together until they enter the workplace.*
5. *To promote an integrated or “whole building design” approach to new construction. This approach differs from the traditional design/build process because the design team considers the interactions of all building components and systems to create a more comfortable building, save energy, and reduce environmental impact.*
6. *To demonstrate to the public the potential of zero-energy homes, which produce as much energy from renewable sources, such as the sun and wind, as they consume. Even though the home might be connected to a utility grid, it has net zero energy consumption from the utility provider.⁵*

EXHIBITION HOUSES

The North House's primary platform as a demonstration house was the 2009 Solar Decathlon. During this event the house became a fully-functioning exhibit piece, in order to communicate the objectives and innovations of the project to the nearly 20,000 visitors it received. North House sought to offer a new vision of the domestic environment with a position on sustainable living that prioritized technological integration, advanced materials and methods, luminous small spaces, and the pleasures of the good life. Positioning the North House as a model of the *new* with respect to its design and the domestic futures it anticipates, locates the project within a long tradition of Exhibition Houses.

In her essay "The Exhibitionary House," Beatriz Colomina observes that many of the most influential houses of the twentieth century were produced for exhibits.⁶ Such projects have always had a strong influence within the design community. When Philip Johnson was organizing the International Style Exhibition at the Museum of Modern Art in New York (MoMA) in 1936, he referred to the private house as the best way to popularize a *style*. Exhibition houses, however, have the power to reach far beyond the design community. Exhibiting new ideas about architecture, domesticity, lifestyle and technology, they have often been on public display in art galleries and fairs, as well as developer model homes. The breadth of the audiences that these exhibits reach is only one reason they have been so influential. Most markedly in the years immediately following the Second World War, Americans were shifting from a period of great sacrifice to one of great optimism. Homes and home furnishings were advertised as exemplars of a new lifestyle.⁷ The single family dwelling has a particular character that is easy for people to relate to, and can speak clearly about a way of life. Elizabeth Mock attributes the birth of lifestyle to the complete design of the single-family dwelling and its popularization. She describes the house as "...an outgrowth and expression of the best conceivable pattern of your life."⁸ We can all understand how the design of a house can relate to our own homes, and our own lives. The exhibition house breaks down the barrier of representation, in a way few other media can. Visitors can easily apprehend new concepts, and experience them in a visceral way. The designer's intentions seem so effortlessly expressed that one might forget the designer altogether, instead envisioning oneself as master of the house.

Notably, influential exhibition houses began to appear in the years following the First World War, although the height of their popularity followed the Second World War. Le Corbusier's *Pavillon de L'Esprit Nouveau*, shown at the 1925 Exposition Internationale des Arts Decoratifs, was one such example. Free of the Art Deco style that the exposition sought to display, its aim was to "redefine the 'decorative' in terms of the object of everyday use, as the banal and the unadorned."⁹ Following the *Pavillon de L'Esprit Nouveau*, domestic settings grew in popularity as attractions at world's fairs. A group of thirteen model homes was one of the major attractions at the Century of Progress International Exposition in Chicago in 1933, the houses intended to show the "impact of modern technology on residential architecture."¹⁰ The Great Columbian Exhibition of 40 years prior, while exhibiting a staggering range of new technologies and experiences, did not exhibit any house designs. The Walker Art Centre in Minneapolis hosted two full scale prototype houses, *The Idea House One* and *Two* in 1941 and 1947, and the Museum of Modern Art in New York (MoMA) began its tradition of



fig 1.7 - the 2009 Solar Decathlon

full scale houses constructed in the museum garden when it hosted a house of Marcel Breuer's design in 1949. All of these houses were demolished after their period of exhibition, although in many cases replicas were constructed later in different locations.

The Case Study House Program begun in 1945 differed in this respect. These houses were built on dispersed permanent sites, mainly in the Los Angeles area, but they were widely visited with the first six projects attracting 350,000 visitors. Sponsored by Arts & Architecture magazine, the program engaged prominent architects to design and build prototype homes that would capture the spirit of post war America and create affordable housing solutions using materials "best suited to the expression of mans life in the modern world."¹¹

Buckminster Fuller's *Dymaxion House* pursued this idea even further. The original 1927 design was intended for mass production and, unlike most other prefabricated houses of the time, it celebrated its method of manufacture. Made of light sheet aluminum panels, the entire house could be collapsed into a small cylindrical container for shipping. A radial plan allowed for all services to be grouped into a central mast that also provided the primary structure off of which the inhabitable space of the home was held in tension. While the house was never mass-produced, a Dymaxion bathroom module was commercially available in limited numbers. It consisted of a fully equipped bathroom in a single piece that could be disconnected from one building in order to be relocated to another.¹² Fuller's Dymaxion concepts anticipated current manufacturing discourse in many ways. He proposed that Dymaxion Houses could be rented by their occupants from the supplier who would service the building throughout its life. Eventually the house could be disassembled and its component parts returned to the manufacturer for recycling or reuse.¹³ This early example anticipates Extended Producer Responsibility (EPR), a practice which is only today beginning to become widespread. EPR and product take-back legislation make manufacturers responsible for their products throughout their entire life-cycle. The *Dymaxion House* was not, however, constructed until 1945, when two prototypes were built. They were purchased by William Graham who combined them as part of his home where his family proceeded to reside for decades. In 1991 they were donated to the Henry Ford Museum in Dearborn Michigan, where they were combined into a single house, and after much restoration opened for public visitation in 2001. That the houses could be reused in this way is owed to Fuller's component-based design which enabled the house to be disassembled and transported with ease.

In 2008, MoMA held an exhibit of full scale model homes entitled *Home Delivery* which focused on prefabricated architecture. Because of unusual siting and short-term display, pairing exhibition with prefabrication seems advantageous, as prefabrication can offer greatly shortened assembly times. Most prefabricated architecture doesn't also require quick disassembly although this would be an asset to almost any exhibition house.

One house that enables rapid assembly and disassembly is Kieran Timberlake's *Cellophane House*, which was commissioned by and exhibited at the MoMA's Home Delivery exhibition. *Cellophane House* builds on the *Loblolly House*, a previous project completed by Kieran Timberlake. It adopts *Loblolly House*'s focus on "speed of on-site assembly, design for full disassembly, and a holistic approach to the life cycles of materials".¹⁴ *Cellophane*

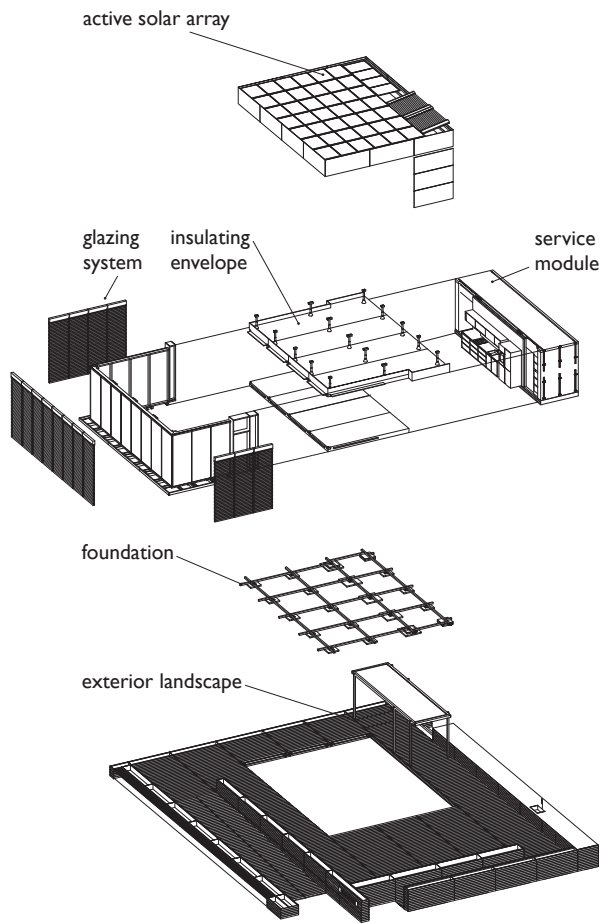


fig 1.8

House further advances these agendas. The house is made up of an aluminum framework into which both panelized and modular units can be inserted. It is rigorously detailed to facilitate separation of components for reuse or recycling. Stephen Kieran and James Timberlake refer to this as “temporarily held assembly” as opposed to “permanently fixed construction”. They stress that what is required for temporarily held assembly to succeed is “...a stratagem of joinery between any two raw materials within systems that allow every element to remain discrete and reusable.”¹⁵ In the *Cellophane House* project exhibition, prefabrication, and a vision of lifecycle-based sustainability meet. The North House likewise strives to combine these three goals.

THE NORTH HOUSE AS A COMPONENT-BASED BUILDING

The North House is an *element-based* or *component-based* building. It is comprised of a number of discrete, pre-manufactured elements that can be assembled and disassembled rapidly and with minimum complexity. These components are organized into systems, which although functionally complimentary, remain spatially independent of one another. This is a type of building organization that Kieran and Timberlake would refer to metaphorically as *quilting not weaving*.¹⁶ This describes building components which can be manufactured simultaneously rather than sequentially, and which join together along a series of joint lines, rather than being inseparably intertwined. The primary component systems of the North House are as follows: foundation, service module, insulating panelized envelope, glazing system, active solar systems, and exterior landscape systems.

The foundation system was designed around the site constraints of the Solar Decathlon, with respect to extent of ground contact permitted and limited load transfer constraints. It can be replaced with an alternate foundation system to suit subsequent sites. The prototype system adjusts to accommodate for terrain variation of up to 24 inches and consists of cribbing pads which spread the load of the building to remain within specified bearing requirements, adjustable scaffold feet and a steel substructure framework, which can be leveled independently and onto which subsequent components can be placed.

Similar to Kieran Timberlake’s *Loblolly House*, the leveling and squaring of the foundation layer of the building is the only step that needs to accommodate site variance. Once the substructure frame is installed and level, assembly can proceed with increased dimensional certainty and speed.¹⁷

The service module of the North House, or *densepack*, is the single most important component of the house. It houses the vast majority of the mechanical and electrical components, all controls systems and electronics, wet services and storage, within a highly insulated enclosure. It is the anchor and reference point used for placing subsequent components during assembly.

In addition to the insulation provided by the densepack, four floor panels and four roof panels complete the insulated enclosure of the North House. The remainder of the building envelope consists of the wood glazing system, within which components such as IGUs, insulated ventilation panels and doors, mullions and mullion caps remain independent from one another.

The active solar array of the North House are mounted to a steel racking system that is separated from the building below, and connects to the roof panels on the outside of the insulated envelope at fifteen bolted connection points. This racking holds the roof-top solar array and solar thermal collectors, as well as associated equipment including inverters, heat dissipaters and weather sensors. The fascia building-integrated photovoltaic (BIPV) cladding panels, the automated exterior Venetian blinds and motor mechanisms, and the wiring bundles that connect and service these systems, are also mounted to this racking structure.

The North House was designed as a component-based building system because of three principle requirements: off-site construction, adaptability, and demountability. In addition to the necessity of off-site fabrication imposed by the Solar Decathlon, the team wanted to investigate factory-built prefabrication techniques in order to explore the possibilities of mass production and mass customization, and to ensure a high-quality, high-performance product that would take advantage of dimensional tolerance and quality control potentials of the factory environment. Adaptability that would allow the components of North House to be replaced or reconfigured was important for two reasons. First, North House would be used as a research laboratory to test the performance of various building systems, and this could require certain components or systems of the house to be replaced with alternates over time and as technologies and material advancements emerge, or as weaknesses in the original design become evident. Second, as the North House is a proof-of-concept prototype, its components needed the ability to be rearranged at different scales and in different configurations. The team sought to develop a language of element detailing that lent itself to different spatial products and residential types. Demountability paired with a formal desire for concealed fasteners in order to prioritize surfaces, materials and systems rather than the history and logics of its making, presented a significant design challenge for the team. This added parameter required a unique prefabrication strategy, achieved through the use of many innovative strategies and details.

Design for disassembly was not a specific agenda of the North House project, but given that the team has designed a completely demountable component-based building, it is valuable to consider other opportunities that this could present. Building on the principles that Buckminster Fuller wanted to apply to his *Dymaxion House*, and further incorporating the principles described by William McDonough and Michael Braungart in their book *Cradle to Cradle*, buildings might be designed in such a way that their components could go on to be useful at the building's end-of-life. Designing a system in which components can be reused or recycled not only serves broader sustainable objectives by diminishing landfill waste and decreasing the need for new materials to be extracted and processed, but could also offer an economic advantage to building manufacturers if components and materials could be effectively repurposed.

SITUATING THE THESIS

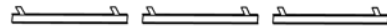
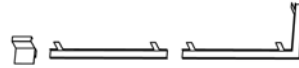
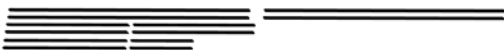
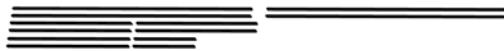
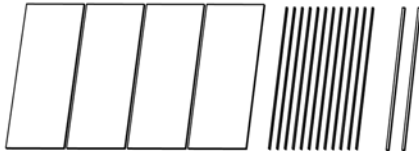
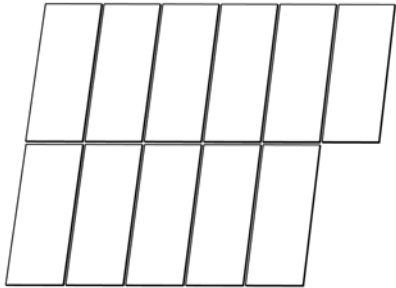
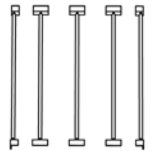
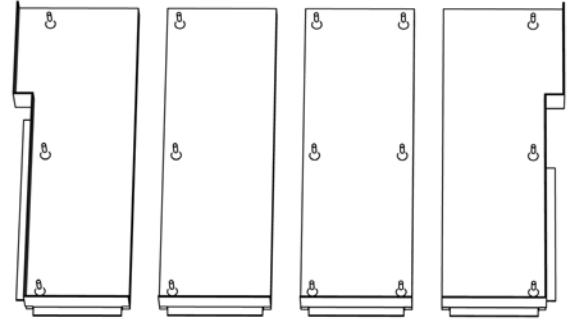
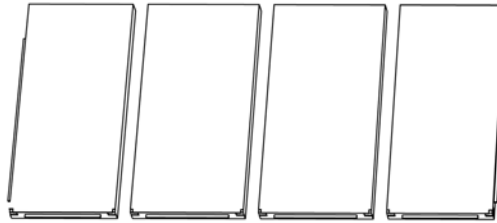
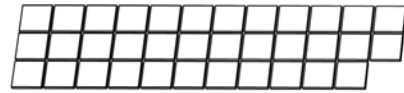
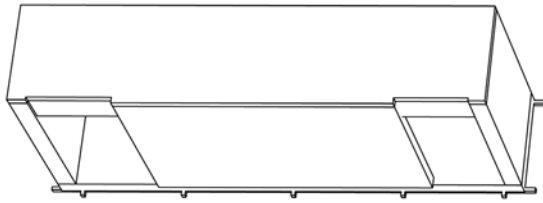
This work is positioned within the context of a directed faculty led research project, on which I worked from September 2008 to October 2009 in the role of Architectural Designer focusing on the formal, spatial and assembly logistics of the project across all phases of its development, as part of the broader team of collaborators, and under the direct supervision of Professor Thün. During the design phases of the work this involved intensive virtual modeling of the project and its components, which was used to test both the formal implications of certain design decisions, and anticipate the tectonic and detailing approaches to the project's fabrication. During the development of detailed construction drawings, I was responsible for drawing set coordination with a specific focus on the structure and building envelope.

Although the project was designed to anticipate its fabrication through an elemental or component-based method, the contract documents for the project were produced in a traditional mode. Rather than as a set of separate elements, the project was depicted as an assembled whole. As a result, a second phase of design refinement occurred in parallel with the construction and fabrication process where shop drawings for each element were made based upon the original configuration and performance intent of the contract drawings. During this phase the design was refined in light of manufacturing constraints, construction methods, and material substitutions that improved upon particular dimensions of the design. This work was developed closely with Jack Debski, project coordinator for MCM 2001 Inc., Professors Thün and Lieberman, Chris Black and Brad Paddock, a member of the student team with extensive fabrication expertise. During the period of construction and fabrication I worked in direct daily contact with the fabricator, at their factory location as a lead student contract administrator. This proximity to process and fabricator knowledge and feedback allowed for very compressed decision-making times, and often instantaneous execution of design innovations.

The drawings that follow were produced after completion of the Solar Decathlon installation, and incorporate the as-built details developed through this process. Although they synthesize the work of a large team, they have been produced by this author as a terminal record of the prototype's design, fabrication and construction.

The following section describes the components that make up the North House, the assembly sequence that joins them together and the details that allow for the building's rapid assembly and disassembly. The order of the assembly sequence is important even though in many cases multiple activities are able to occur simultaneously.

ASSEMBLY



SUMMARY OF COMPONENTS

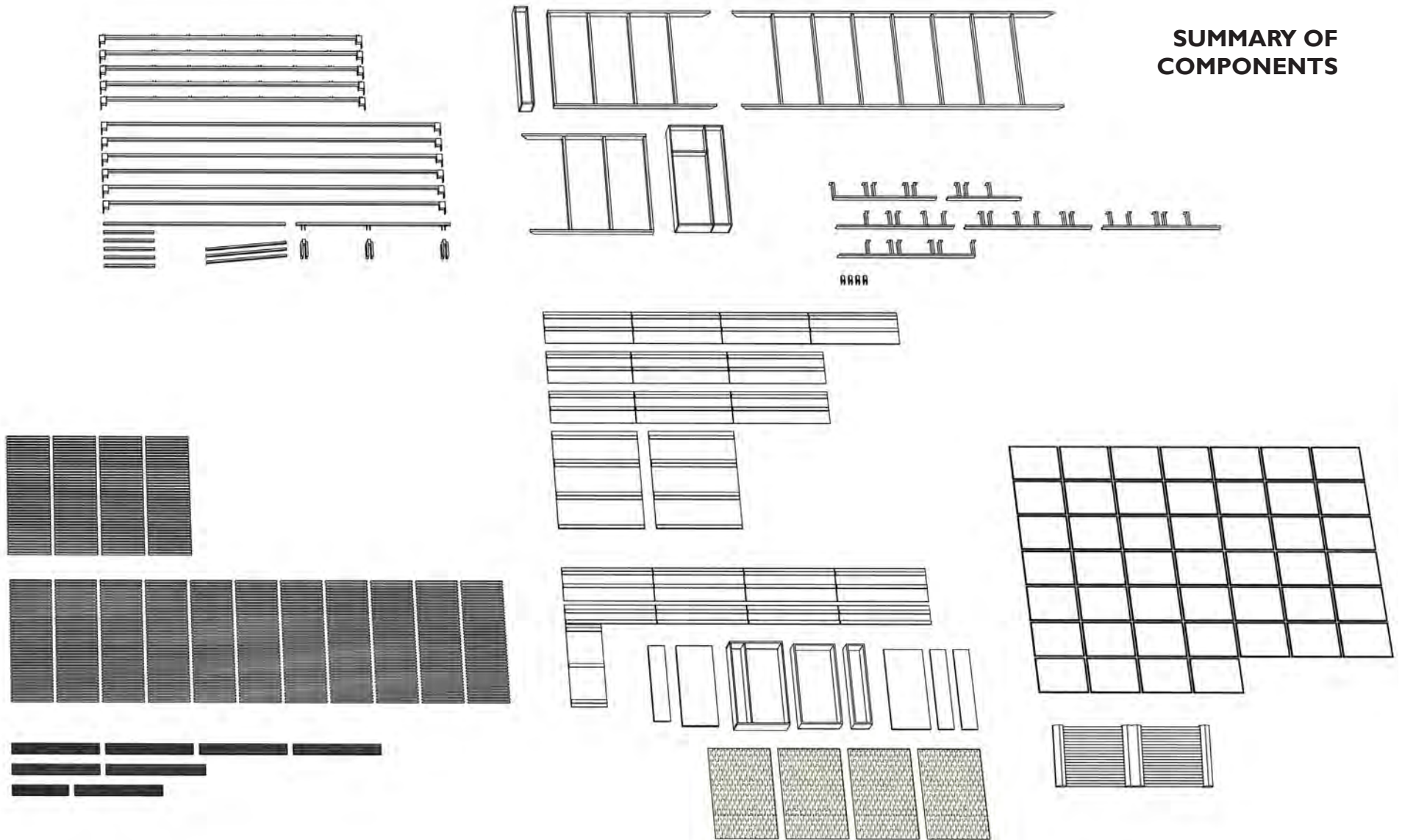
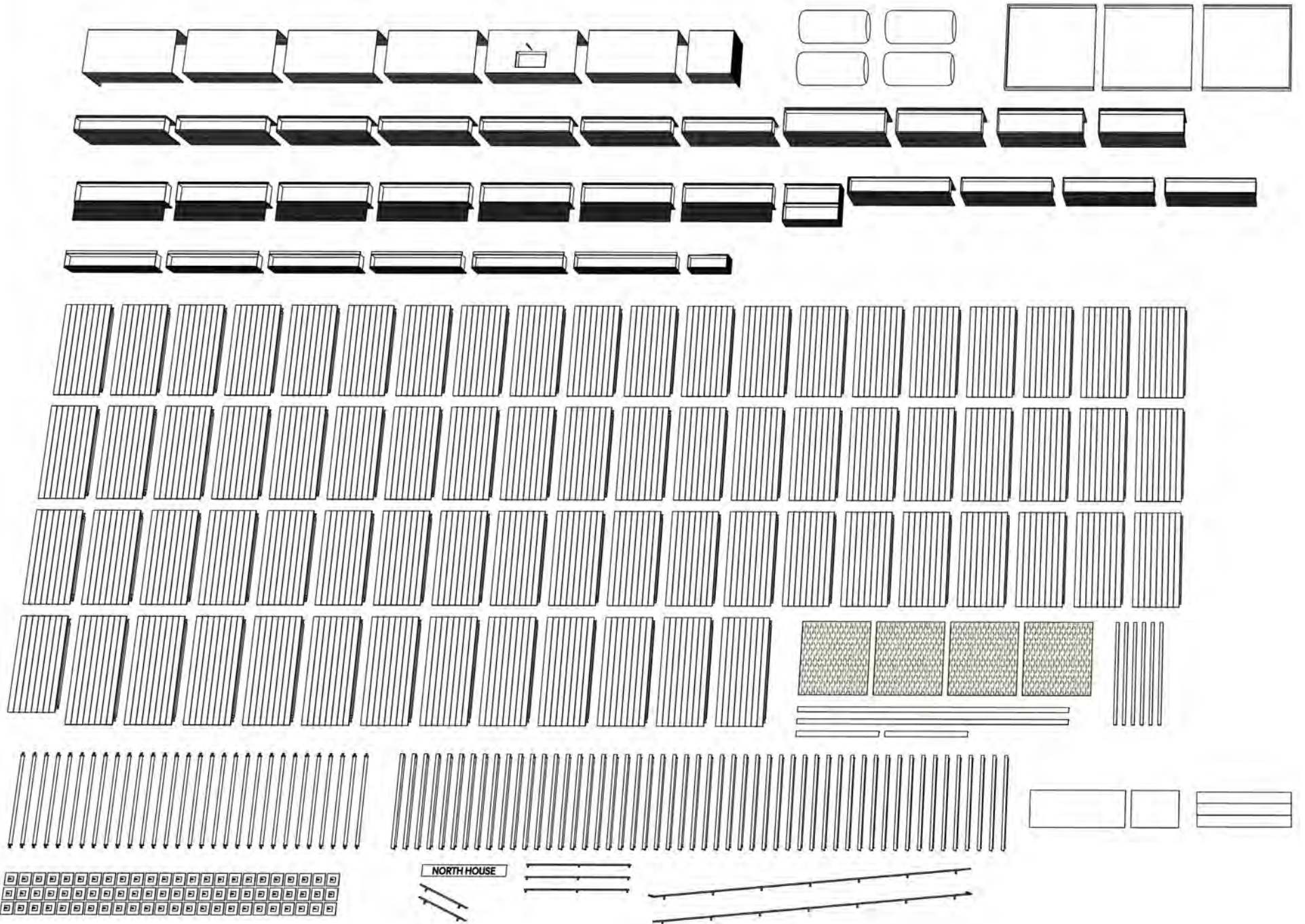


fig 2.0.1



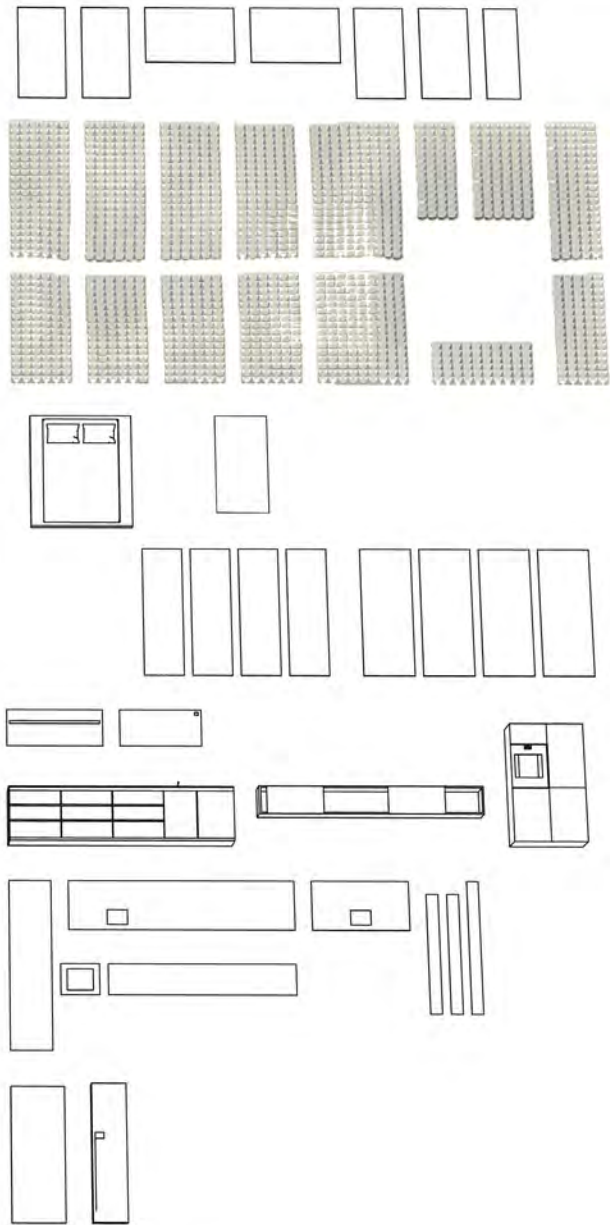


fig 2.0.2

SUMMARY OF COMPONENTS

MAIN HOUSE # of pieces

cribbing pads -	50
steel plates -	20
scaffold feet -	16
densepack -	1
steel substructure -	17
floor panels -	4
roof panels -	4
angle brackets -	6
threaded rods -	8
roof racking upstands -	15
steel columns -	5
roof racking frames -	5
purlins -	12
cross braces -	3
solar thermal rack -	1
mullions -	22
insulated ventilation panels -	4
exterior doors & frames -	4
window frames -	2
insulated glazing units -	18
pressure plates -	12
cover plates -	12
mullion caps -	12
corner inserts -	2
aluminum closer panels -	18
blind supports -	13
cladding supports -	14
exterior blinds -	15
cedar grate -	8
BIPV cladding panels -	14
Crezon cladding panels -	9
expanded metal panels -	4
solar panels -	46
solar thermal collectors -	2

TOTAL - 406

INTERIOR # of pieces

sculptural ceiling panels -	15
Douglas fir ceiling panels -	8
cable suspended bed -	1
Douglas fir transoms -	2
glass doors -	10
kitchen with appliances -	16
Corian finish panels -	8
Douglas fir door -	1
Douglas fir bookshelves -	5
Douglas fir closets -	4

TOTAL - 70

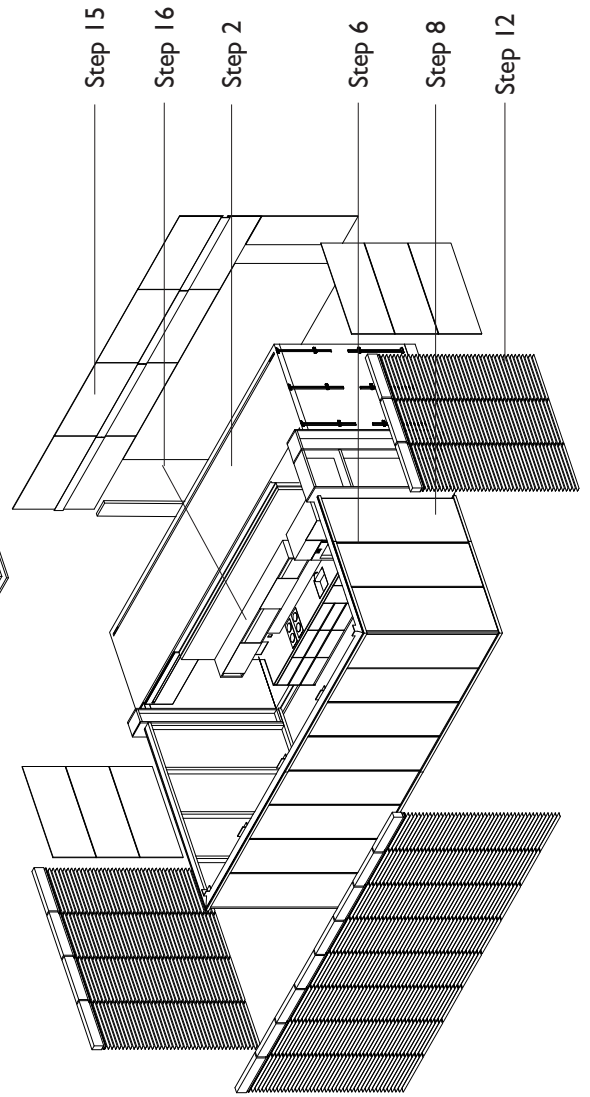
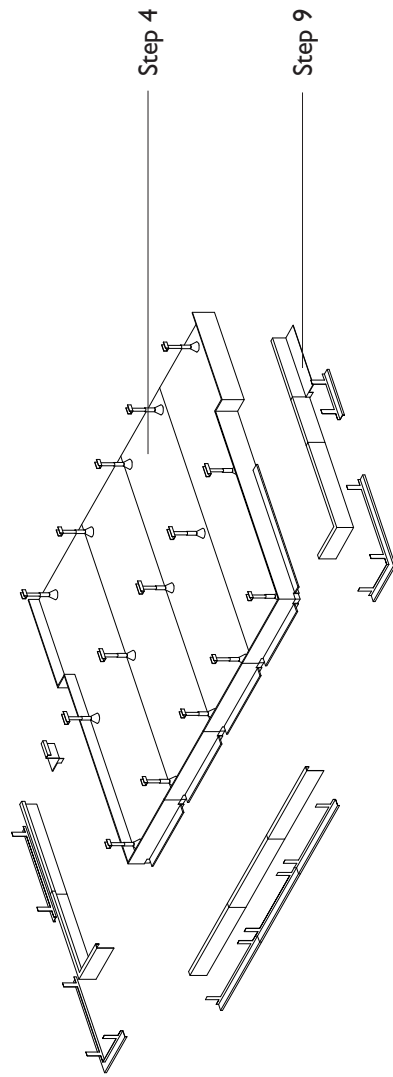
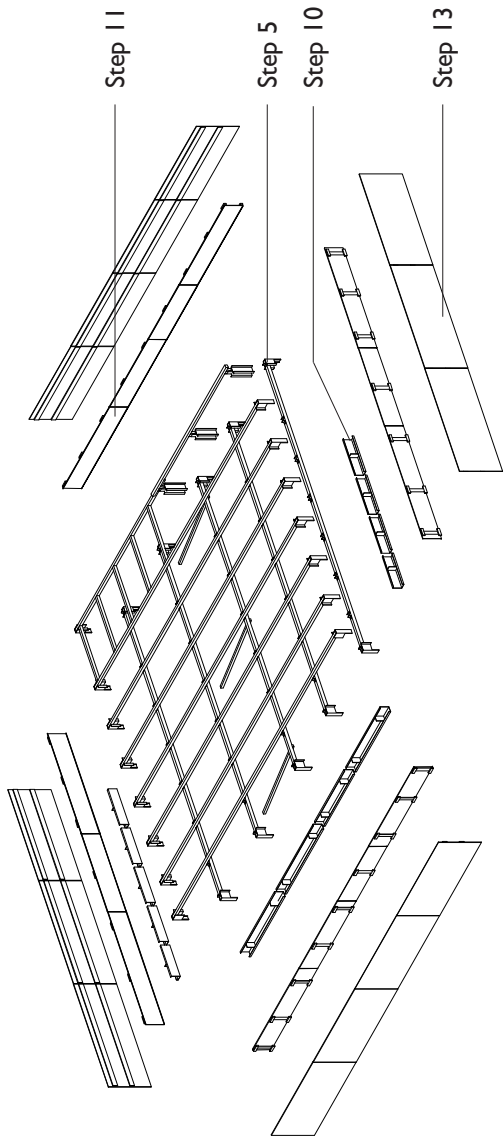
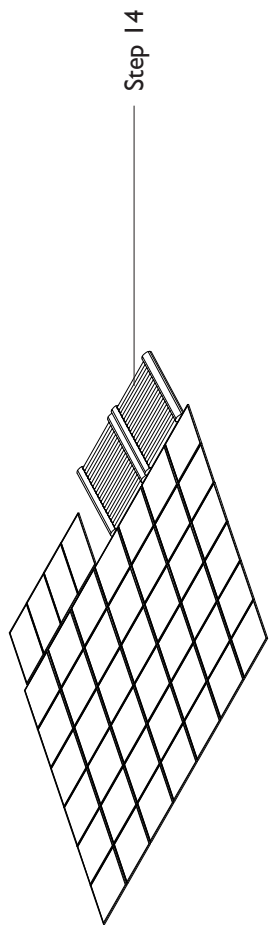
EXTERIOR # of pieces

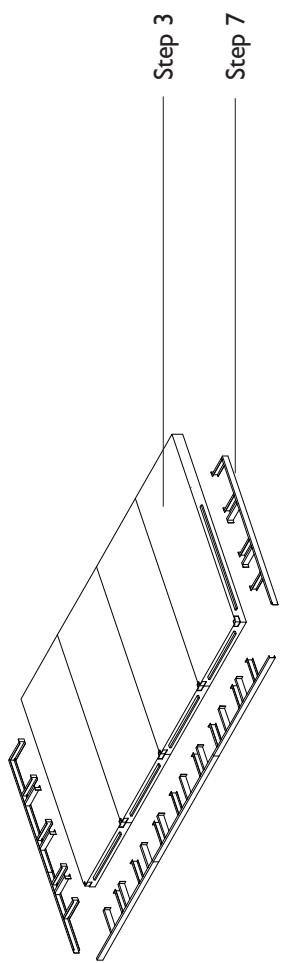
water tanks -	4
heat rejection pond -	3
site built stair -	11
storage cabinets -	7
herb garden planters -	4
various planters -	27
cedar deck panels -	73
scaffold ledgers -	82
scaffold feet -	75
cribbing pads -	75
checker plates -	2
expanded metal mesh -	4
aluminum angle segments -	4
aluminum columns -	6
entry sign -	1
handrails -	7

TOTAL - 385

OVERALL TOTAL - 861

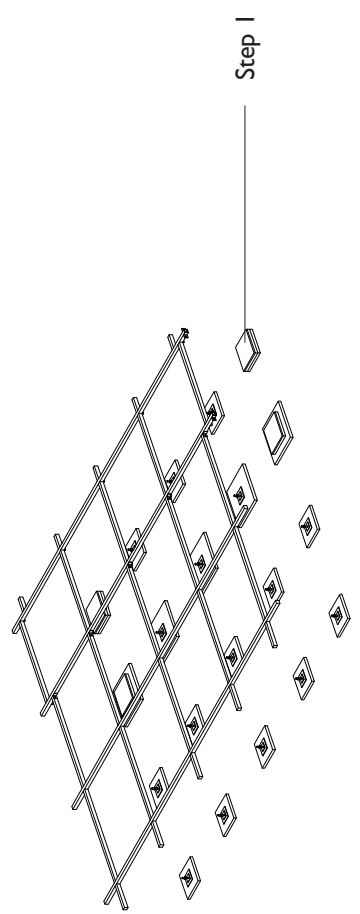
(does not include fasteners or hardware)



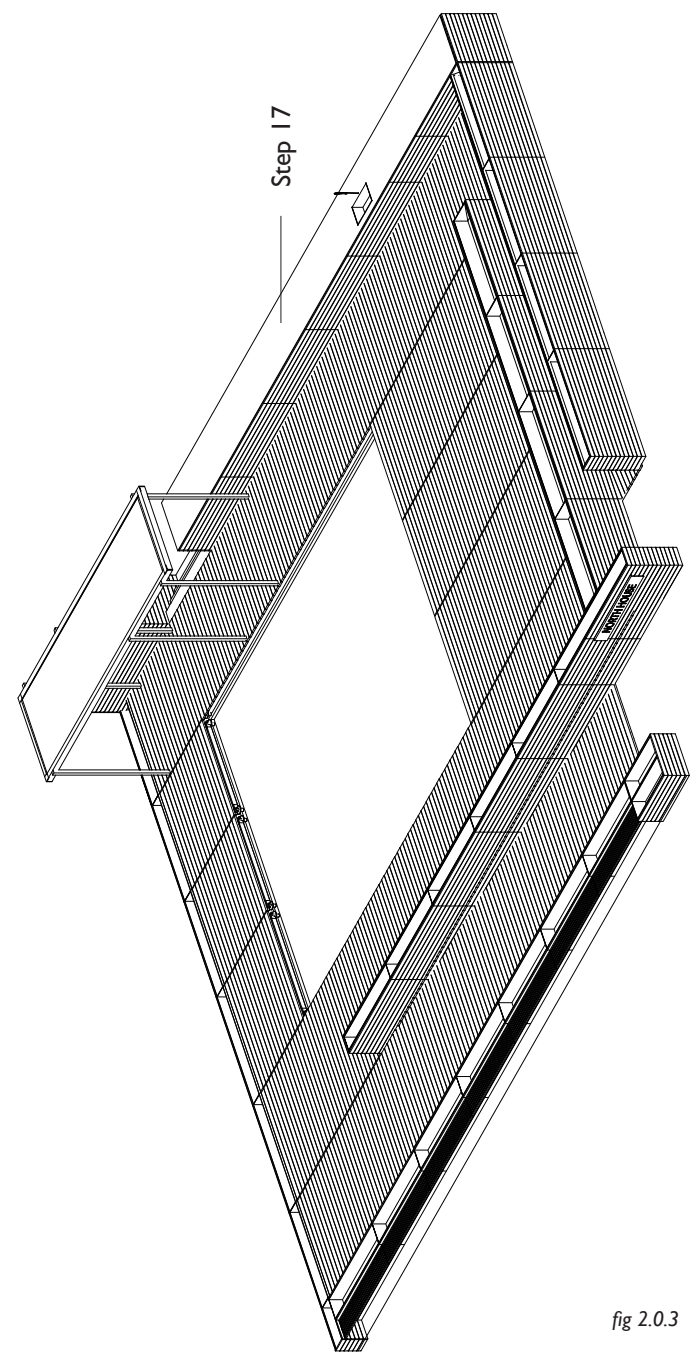


Step 3

Step 7



Step 1



Step 17

- Step 1 - Site Survey & Prep
- Step 2 - The Densepack
- Step 3 - Floor Panels
- Step 4 - Roof Panels & Columns
- Step 5 - Roof Racking
- Step 6 - Mullion Frames
- Step 7 - Base Support Frame
- Step 8 - IGU & Mullion Caps
- Step 9 - Aluminum Closer Panels
- Step 10 - Exterior Blind Supports
- Step 11 - Fascia Cladding Supports
- Step 12 - Exterior Blinds
- Step 13 - BIPV Cladding Panels
- Step 14 - Solar Panels & Solar Thermal Collectors
- Step 15 - North Wall
- Step 16 - Interiors
- Step 17 - Exterior Landscape

fig 2.0.3

STEP 1: SITE SURVEY & PREP

The first step to assembling the North House is to survey the entire site where the house will be erected. This is to ensure that when the first module is placed it is at a level that will not cause a conflict at any other point below the house or deck. The underside of the substructure of the densepack should be no less than seven inches above the highest point on the site. It is equally important that the densepack be placed correctly relative to the edges of the site, according to the survey plan.

The rules of the Solar Decathlon state that bearing pressure cannot exceed 1500psf at any point on the site. Plywood cribbing pads of various sizes specified by our structural engineer accommodate this requirement by adequately spreading the load of the building. Metal plates on top of the cribbing pads prevent the bases of the scaffold feet from cupping or sinking into the plywood.

The Solar Decathlon competition rules also state that teams must employ footings that accommodate 18" of vertical variation on the site. This is achieved using off-the-shelf scaffold feet, the threaded rod portion of which come in various lengths, and can be cut to length on site. If additional height is needed, then additional plywood cribbing pads can be added under the scaffold feet. Scaffold feet can be pre-adjusted to an approximate height based on spot levels taken at each footing location.

Stacked cribbing pads can be used in place of scaffold feet at the four corners of the densepack. This makes the densepack easier to place, and more stable while final adjustments to the scaffold feet are made.

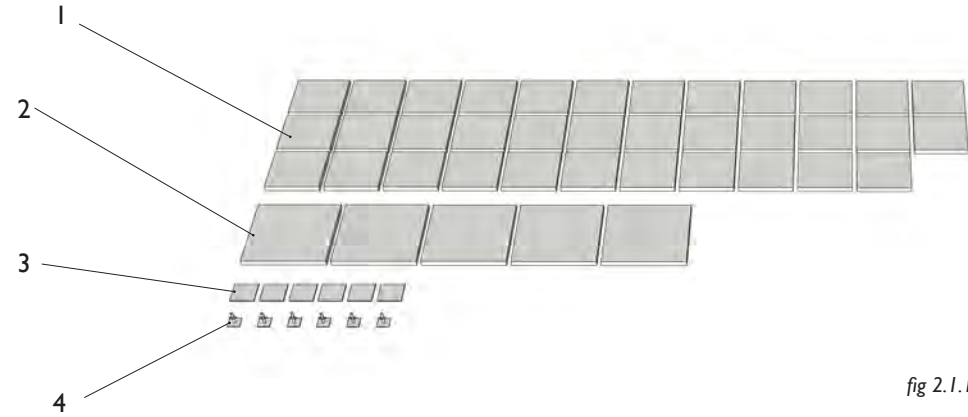


fig 2.1.1

Components placed during this step:

- 1 - approx 35 small plywood cribbing pads (depends on slope of site)
- 2 - 5 large plywood cribbing pads
- 3 - 10 steel plates
- 4 - 6 adjustable scaffold feet

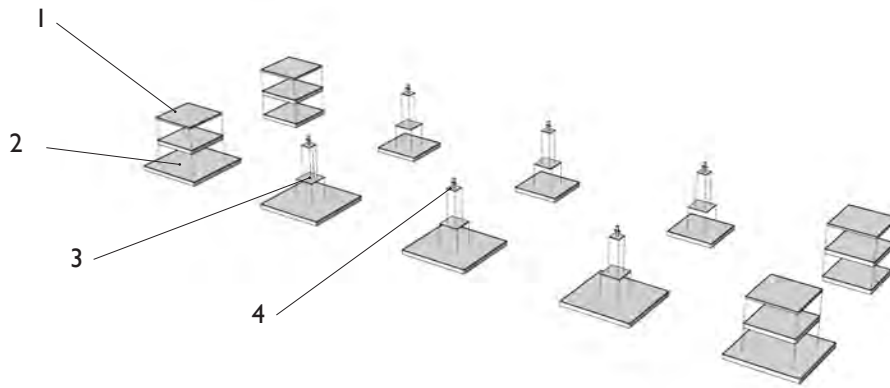


fig 2.1.2

Components as assembled:

- 1 - small plywood cribbing pads
- 2 - large plywood cribbing pad
- 3 - steel plate
- 4 - adjustable scaffold foot

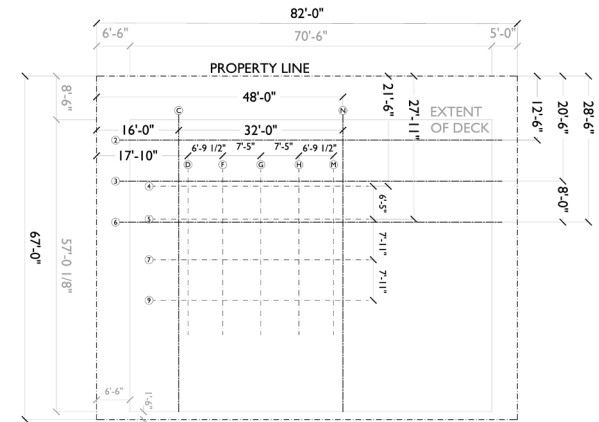


fig 2.1.3 survey plan



fig 2.1.4 setting out the string lines

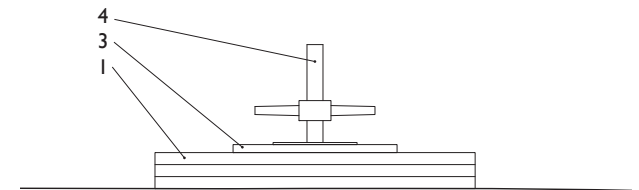


fig 2.1.5 footing detail

- 4 - preadjusted scaffold foot
- 3 - steel plate
- 1 - plywood cribbing pad

STEP 2: THE DENSEPACK

The Densepack is the most important component of the North House. It is the service module for the house, containing almost all of the mechanical, electrical and plumbing systems. Since these systems are time consuming to assemble, they were embedded in the densepack where they could be shipped pre-assembled, and would be protected during shipping. With an R-55 wall assembly it provides a highly insulated zone at the building's north edge. It also provides a stable frame onto which the floor and roof panels can be connected. It is the modular base onto which flat-pack components can be affixed.

The unit was designed as the largest unit that could ship on a single truck without requiring any special permitting to travel from Toronto to Washington D.C.. It must be transported on an extendable double-drop trailer.

The densepack weighs 16,000 lbs and must be craned into place. Elements of the steel substructure, pre-attached to the underside of the densepack, provide an attachment location for the craning shackles. As this is the largest component of the house, it determines the size of crane required.

fig 2.2.1 crane rigging for the densepack

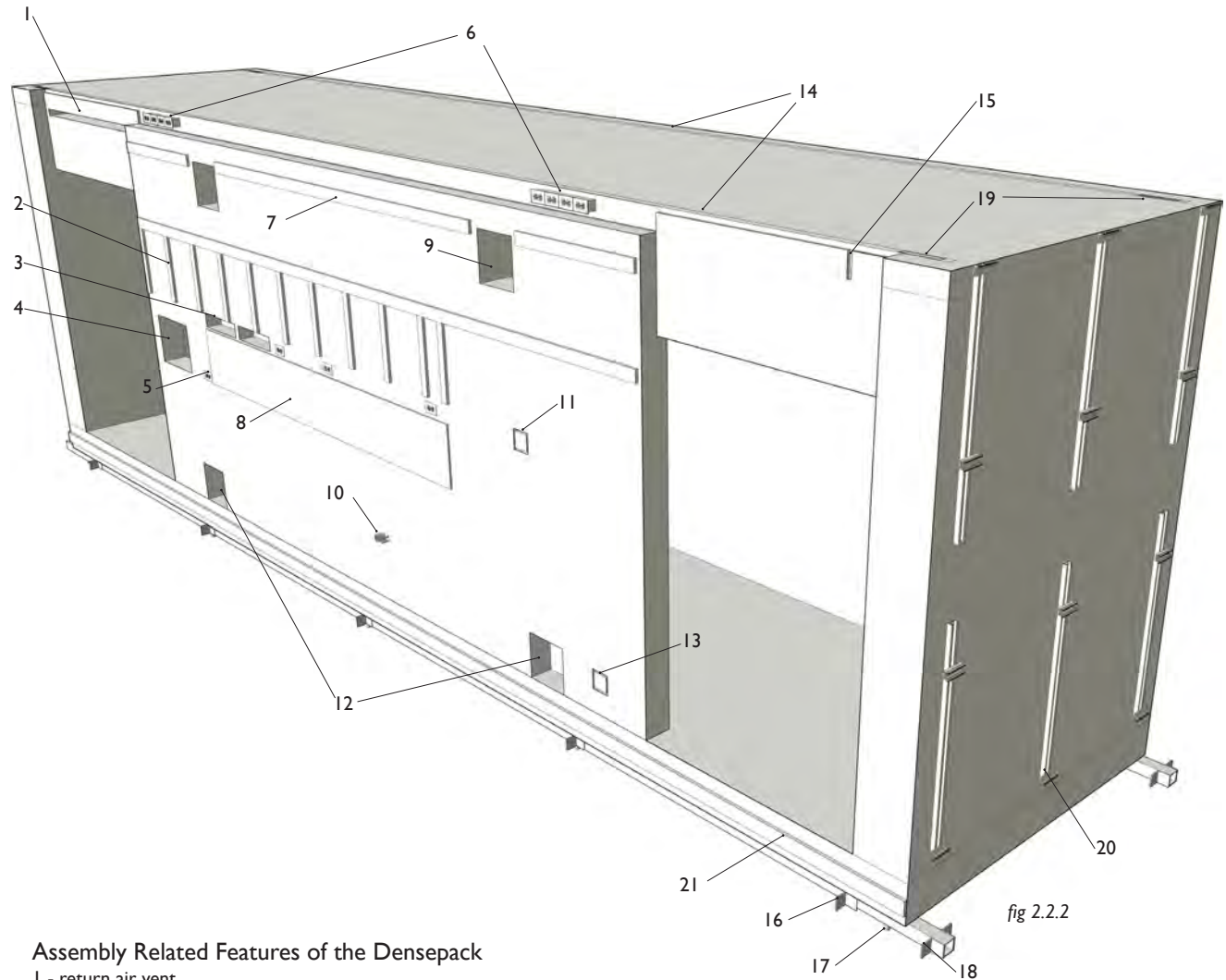


fig 2.2.2

Assembly Related Features of the Densepack

- 1 - return air vent
- 2 - brackets for mounting kitchen uppers
- 3 - range exhaust vent
- 4 - recess for touch screen control panel
- 5 - electrical receptacles for kitchen
- 6 - electrical receptacles for electrical connection to roof panels
- 7 - strapping for mounting Corian cladding
- 8 - 'ambient canvas' LED display
- 9 - supply vent
- 10 - plumbing hook-up for kitchen sink
- 11 - direct electrical connection for oven
- 12 - access for electrical connection to floor panels
- 13 - direct electrical connection for fridge
- 14 - steel lintels for connection to roof panels
- 15 - cut-out for bed suspension cables
- 16 - bracket for connection to substructure
- 17 - sleeve to receive scaffold jack footing
- 18 - bracket for connection to deck substructure
- 19 - cut-out for steel hooks installed on roof panels
- 20 - rails & brackets to support BIPV cladding
- 21 - tongue and groove connection to floor panels

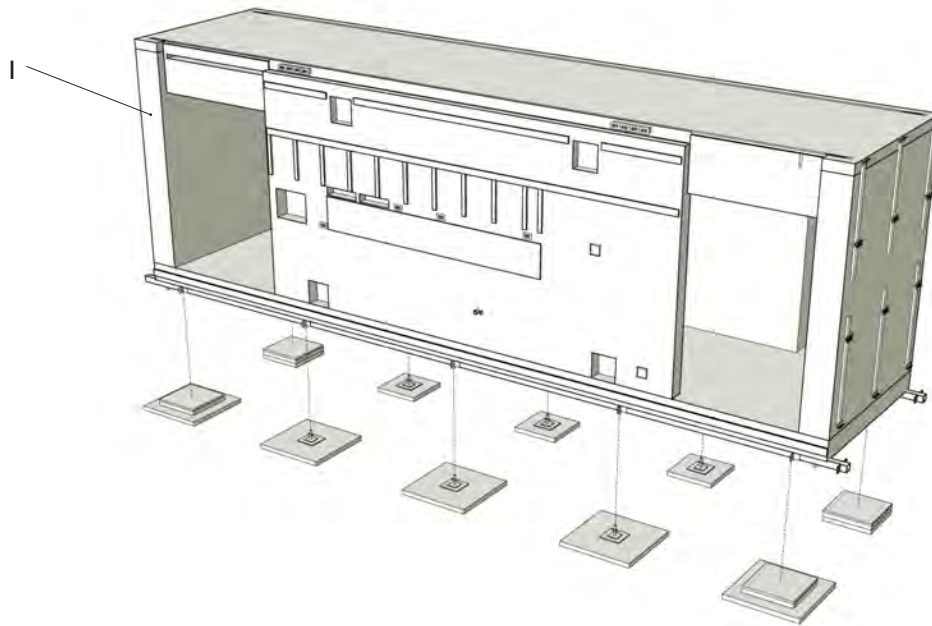
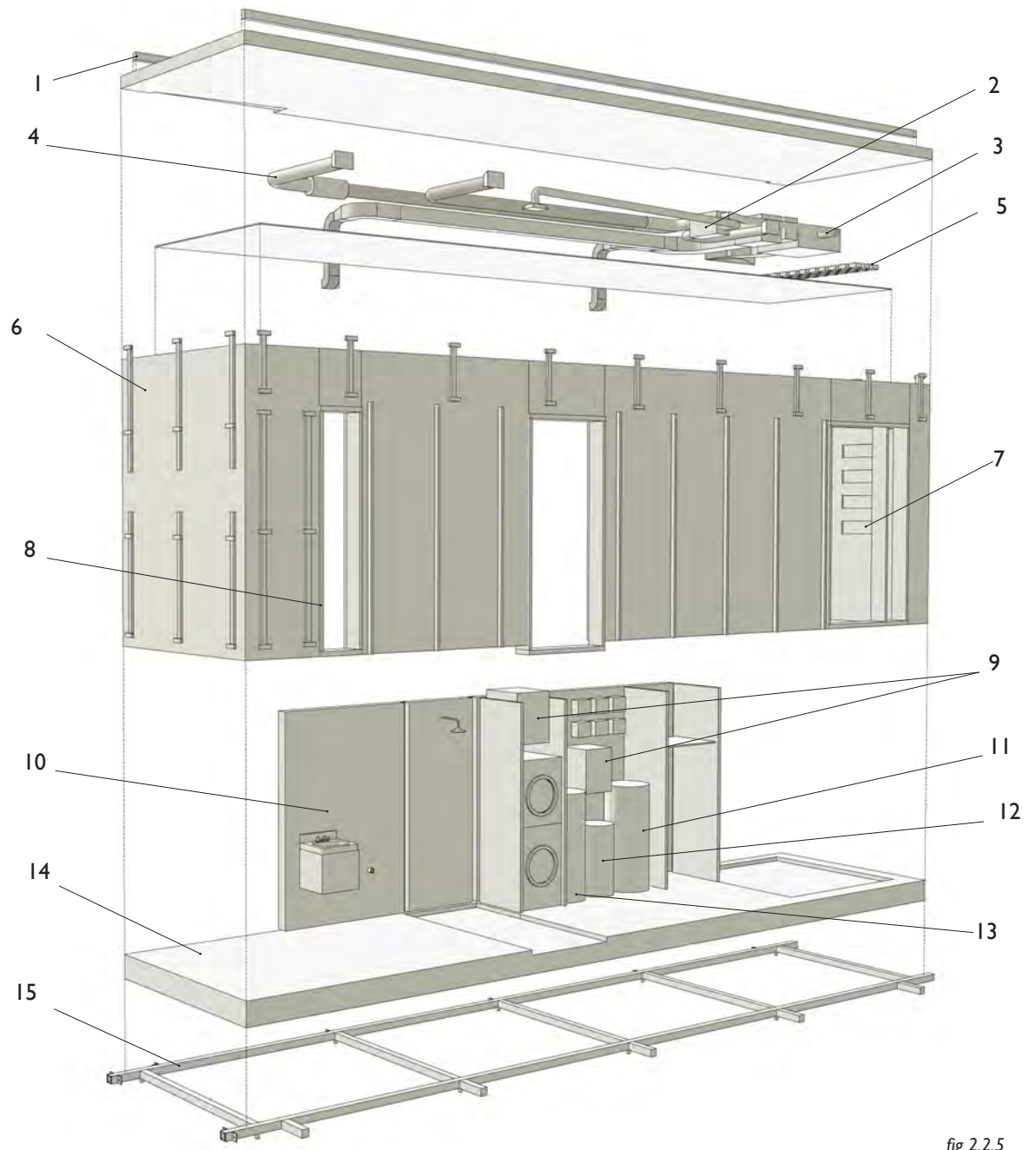


fig 2.2.3

Components as assembled:
1 - densepack placed on cribbing pads and scaffold feet

fig 2.2.4 placing the densepack





Composition of the Densepack:

- 1 - HSS steel lintels (for attachment of roof panels)
- 2 - air handling system
- 3 - heat recovery ventilator
- 4 - air handling unit
- 5 - controllers for exterior blinds
- 6 - R-55 insulated walls with cladding rails
- 7 - fold-out utility wall
- 8 - pre-installed window frames
- 9 - heat pumps
- 10 - bathroom with pre-installed finishes
- 11 - heat storage tank
- 12 - space heating tank
- 13 - domestic hot water tank
- 14 - insulated floor assembly with pre-installed drainage pans
- 15 - steel substructure

fig 2.2.5

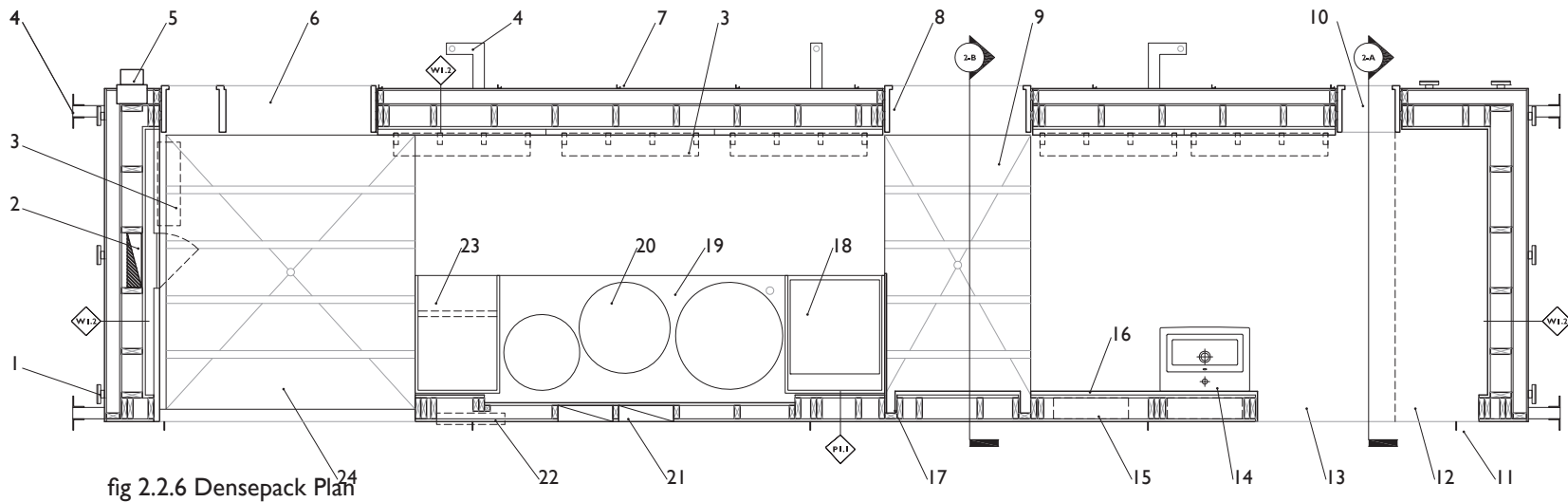


fig 2.2.6 Densepack Plan

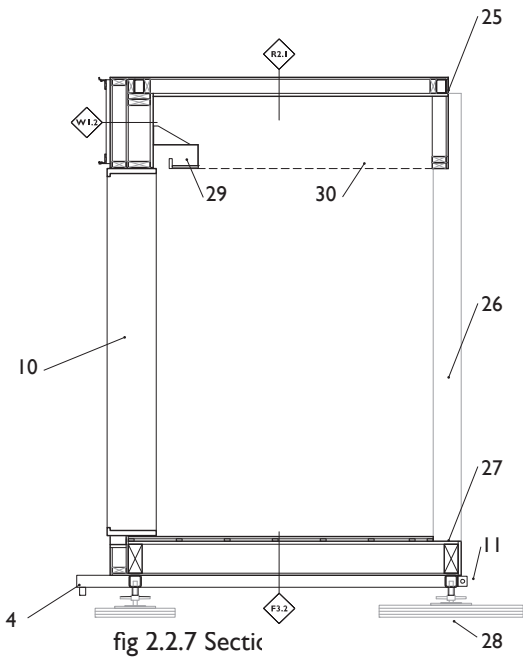


fig 2.2.7 Sectic

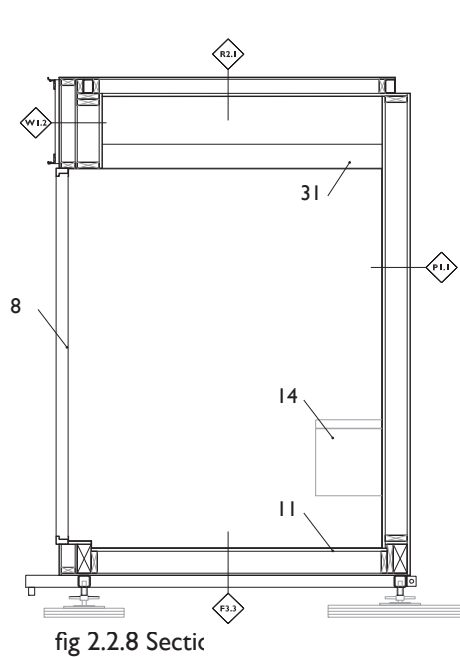


fig 2.2.8 Sectic

Parts of the Densepack

- 1 - rails & brackets to support cladding
- 2 - electrical panel
- 3 - fold-out utility wall
- 4 - steel substructure connection for deck
- 5 - electrical meter base
- 6 - main entry door frame
- 7 - clip connections for panelized mesh cladding
- 8 - shower window frame (w/o IGU or glazing stops)
- 9 - stainless steel drainage pan for shower
- 10 - bathroom window frame (w/o IGU or glazing stops)
- 11 - bracket for connection to substrate
- 12 - area for closet and bed mechanism
- 13 - engineered maple flooring
- 14 - bathroom sink & vanity
- 15 - in-wall carrier for toilet
- 16 - Corian finish panel
- 17 - pocket for sliding shower doors
- 18 - washer / dryer
- 19 - drainage pan in mechanical closet
- 20 - 3 tank water based cascading heat system
- 21 - ducting for range exhaust vent
- 22 - recess for touch screen control panel
- 23 - coat closet
- 24 - stainless steel drainage pan for entry vestibule
- 25 - steel lintel for connection to roof panels
- 26 - doorway to main living space
- 27 - space for threshold strip
- 28 - cribbing pads and scaffold jacks (placed in Step 1)
- 29 - lighting cove
- 30 - space reserved for mechanical equipment
- 31 - support for sliding shower doors

STEP 3: FLOOR PANELS

Based on shipping dimensions, the floor of the North House is divided into four panels.

These panels are supported by a bolt-together steel substructure which attaches to the substructure of the densepack and rests on cribbing pads and scaffold feet similar to those that support the densepack. This substructure can be leveled with ease in advance of the floor panels' arrival. It extends beyond the footprint of the house, as it will also be used to support the deck at the perimeter of the house. This substructure allows the floor panels to be placed quickly, as they already have a level base on which to rest.

The floor panels are shipped on a 53 foot flat bed truck with a retractable tarpaulin cover called a roll-tite. This allows the floor panels to be craned directly from the truck into position. Each floor panel has two threaded receivers in either side where large eyelet bolts can be attached. These are used to attach the craning slings.

There is a gasketed tongue and groove connection between floor panels, and where the floor panels meet the densepack. This helps to ensure that they are positioned correctly relative to one another, and to prevent air leakage between components.

After a floor panel is put in place it is bolted to the substructure from below. This is done for each panel before the next floor panel is placed, as the bolting location becomes inaccessible thereafter.

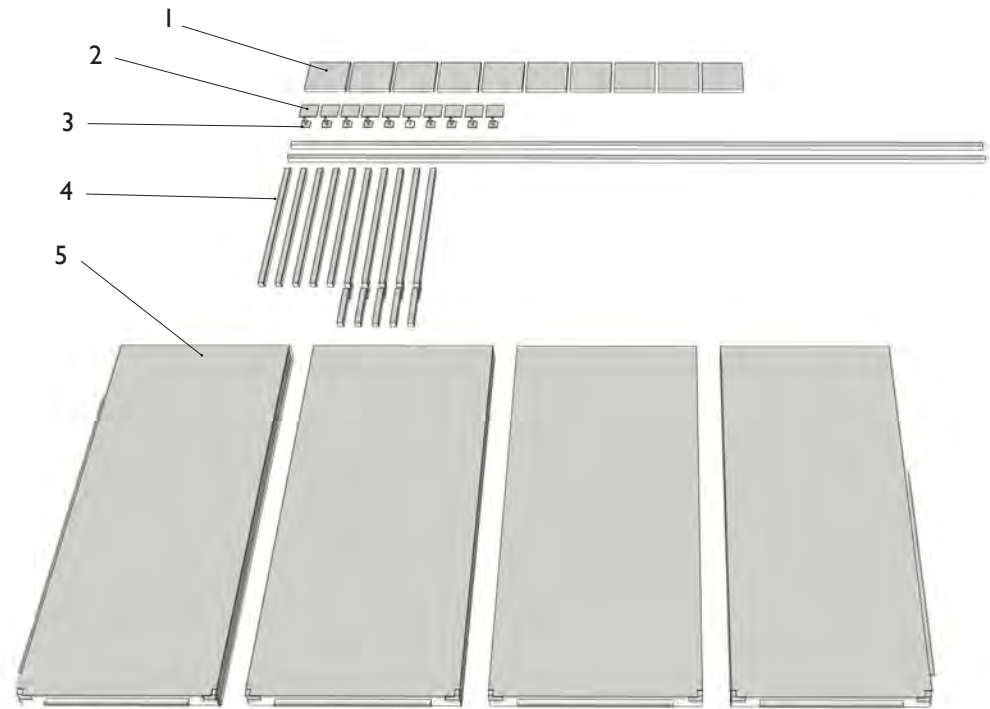
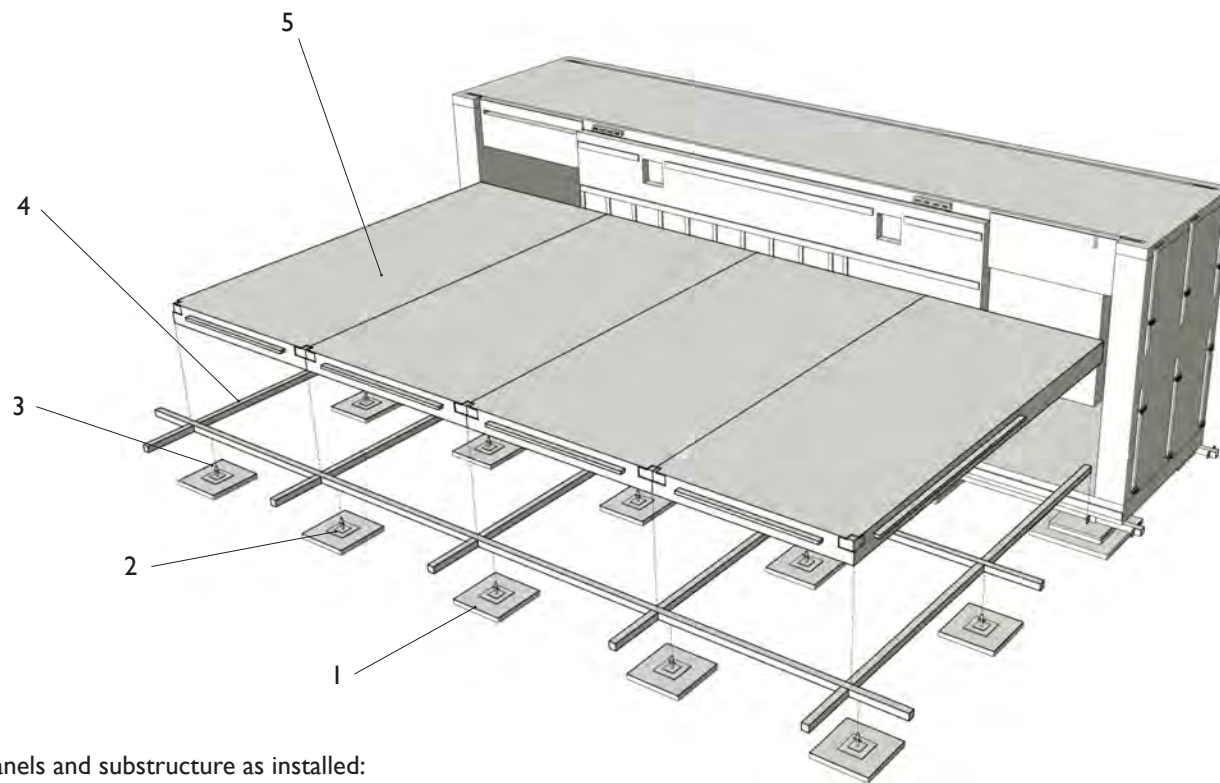


fig 2.3.1

Components placed during this step:

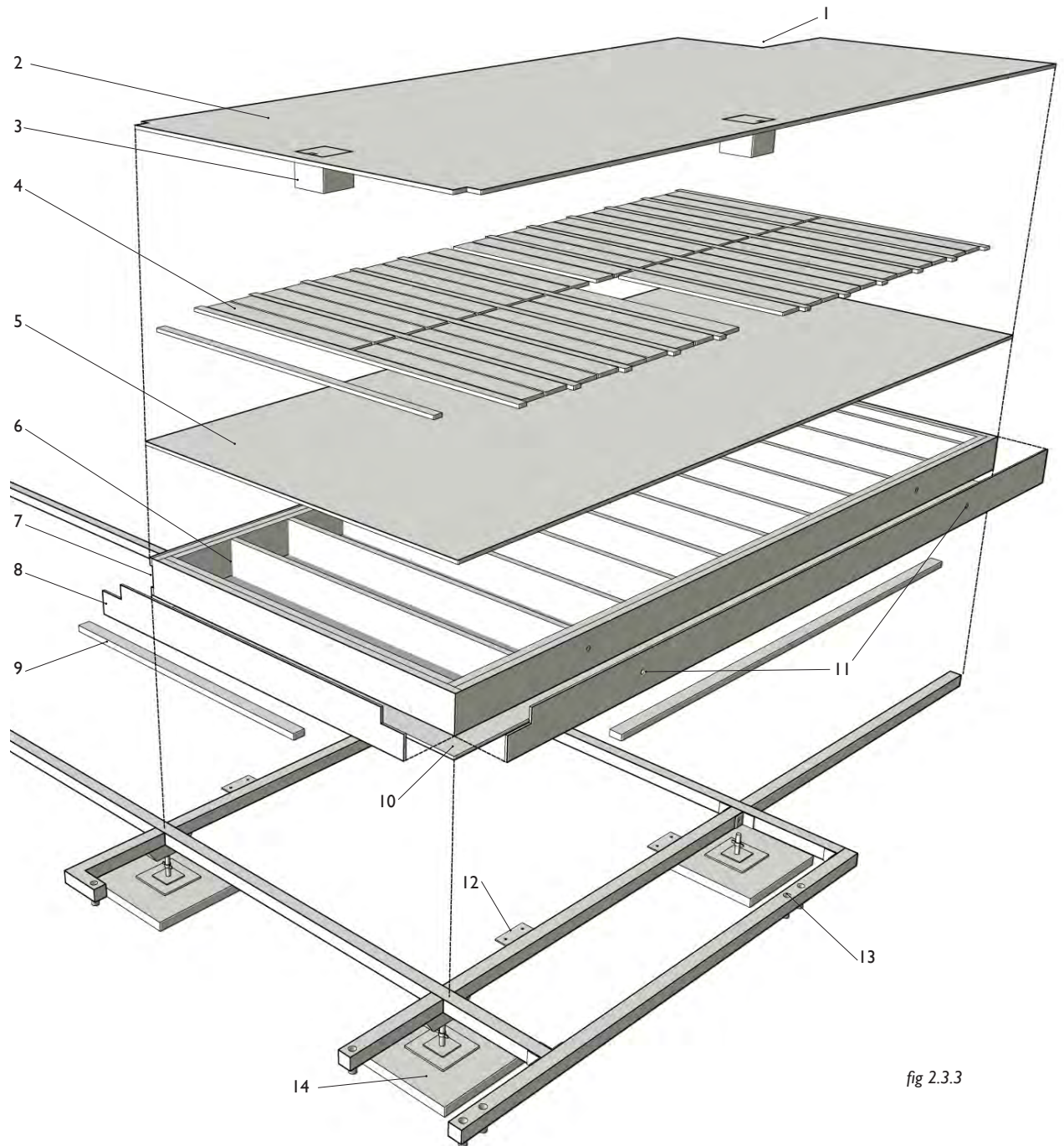
- 1 - approx 10 plywood cribbing pads
- 2 - 10 steel plates
- 3 - 10 adjustable scaffold feet
- 4 - steel substructure (17 pieces)
- 5 - 4 floor panels



Floor panels and substructure as installed:

- 1 - plywood cr bbing pad
- 2 - steel plate
- 3 - adjustable scaffold foot
- 4 - steel substructure
- 5 - floor panel

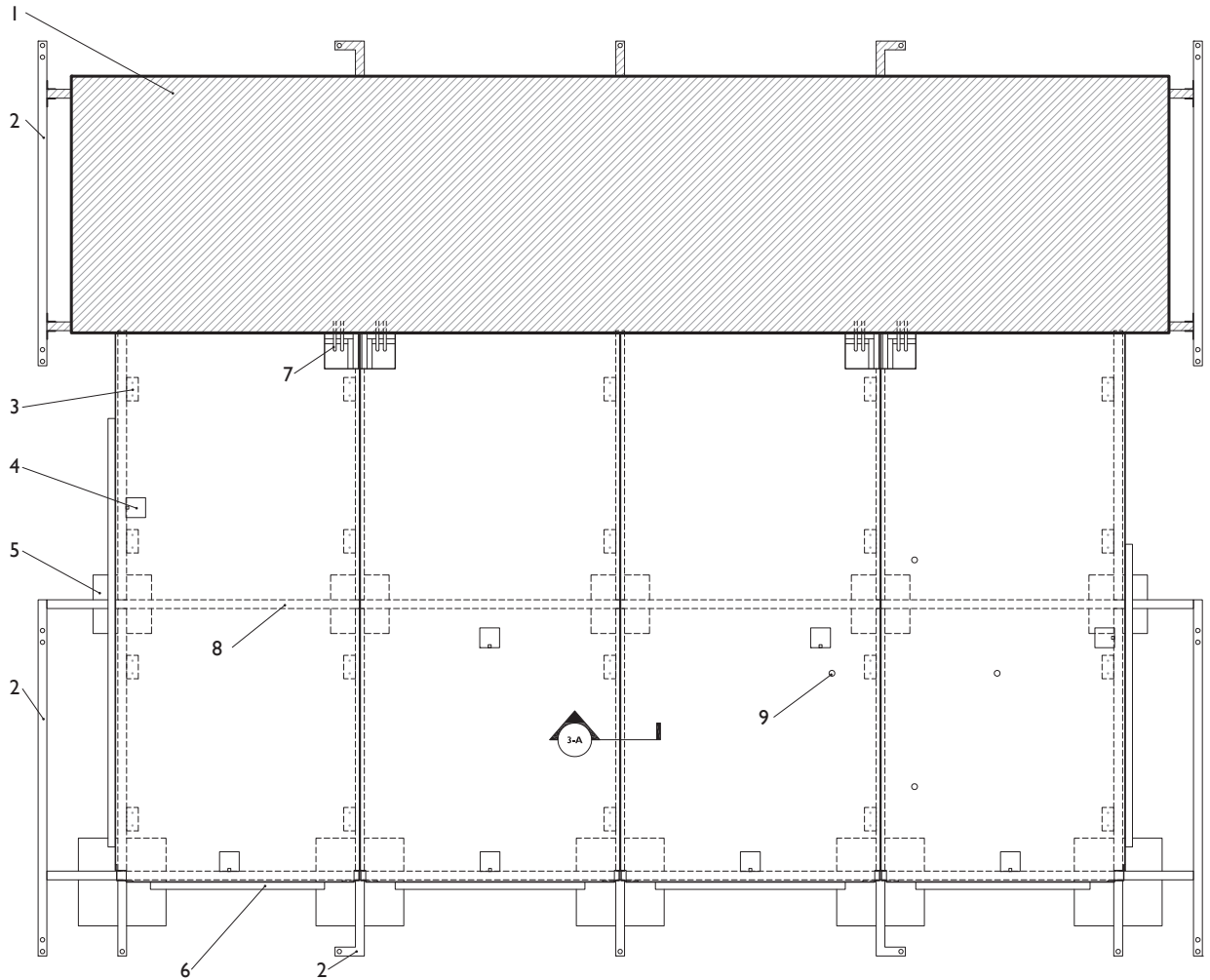
fig 2.3.2



Composition of Floor Panels

- 1 - cut out for electrical connection to densepack
- 2 - engineered maple flooring
- 3 - stainless steel receptacle box
- 4 - phase change materials and wood batons
- 5 - plywood sheathing
- 6 - wood frame with spray foam insulation
- 7 - tongue and groove connection
- 8 - plywood edging
- 9 - Douglas fir blocking for fastening mullion frames
- 10 - exterior grade plywood sheathing
- 11 - holes for eyelet bolts used for craning
- 12 - steel bracket to fasten floor panel to substructure
- 13 - connection points for deck substructure
- 14 - crbbing pads and scaffold feet

fig 2.3.3



- Floor panels plan:**
- 1 - densepack (shown for reference, hatched)
 - 2 - steel substructure to support deck
 - 3 - steel bracket for fastening floor panels to substructure
 - 4 - stainless steel receptacle box
 - 5 - cr bbing pads and scaffold feet
 - 6 - Douglas fir blocking for fastening mullion frames
 - 7 - cut-out for electrical connections to densepack
 - 8 - steel substructure below
 - 9 - threaded connection in floor for cable-suspended bed

fig 2.3.4

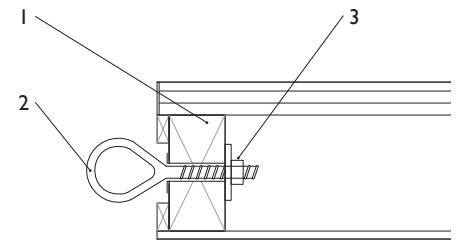


fig 2.3.5 eyelet bolt connection (used for craning)

- 1 - perimeter LVL
- 2 - eyelet bolt
- 3 - preinstalled sleeve & nut to receive eyelet

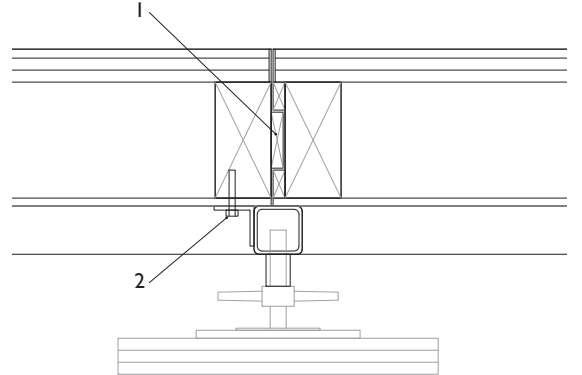


fig 2.3.6 DETAIL 3-A: tongue & groove connection between panels

- 1 - tongue & groove connection
- 2 - bolted connection to steel substructure

fig 2.3.7 placing the floor panels



STEP 4: ROOF PANELS & COLUMNS

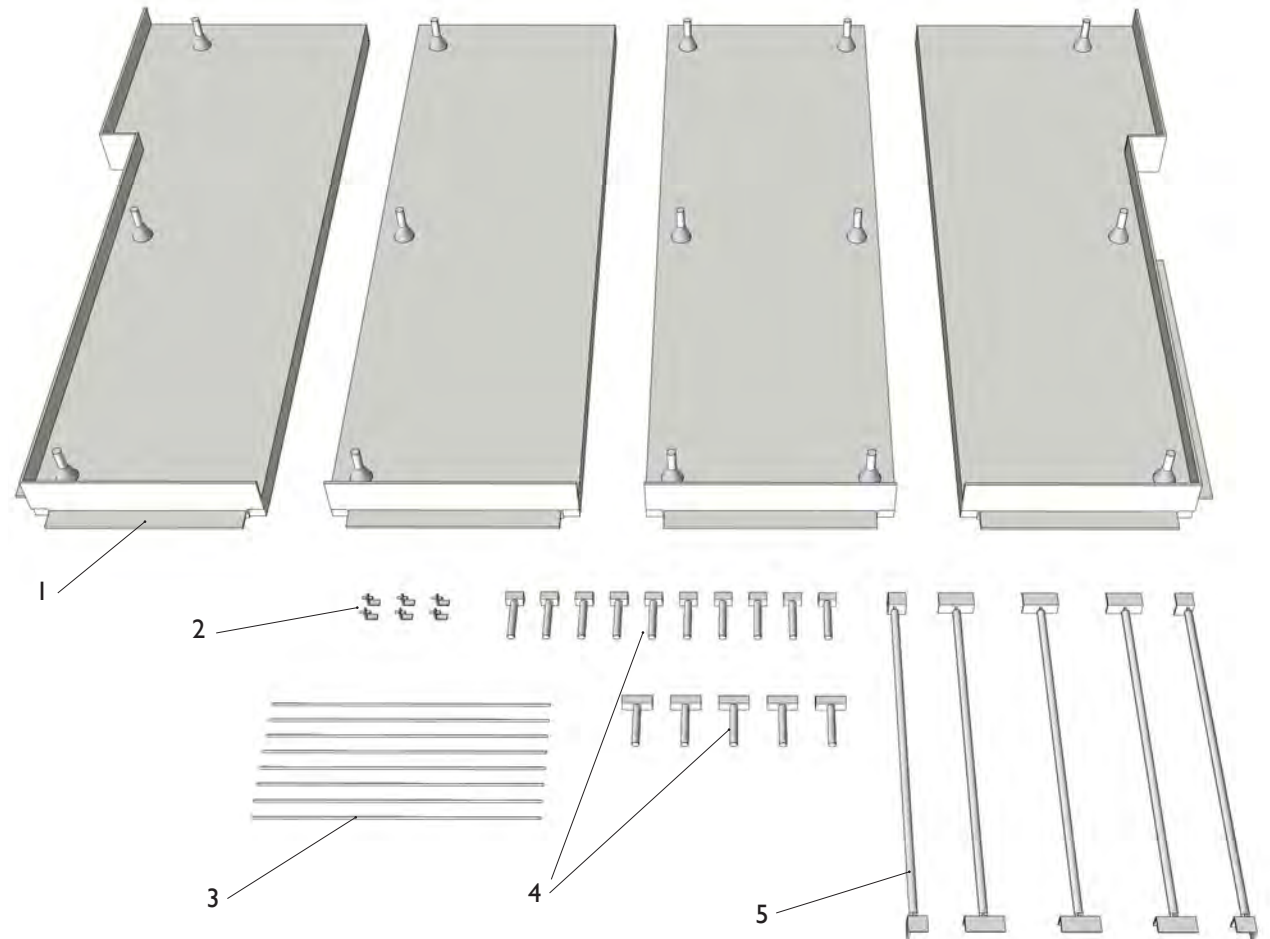
Before the roof panels can be installed, a scaffold holding a temporary support beam must first be erected on the floor panels. This beam holds the roof panels in place until the columns are installed.

All four roof panels must act structurally as a single diaphragm, making the connection between roof panels a particularly challenging detail. This is achieved with a series of different connections. While the north end of the roof panels rest on the densepack, the south end of the panels are supported by the columns. Two HSS steel lintels, embedded in the ceiling structure of the densepack, are used as anchorage points for the roof panels. On the two outer panels a steel hook, fastened to the underside of the panel drops into a hole in the HSS and after it has been slid into place, secures the panel to the densepack. At the joints between panels, a steel rod welded to an angle bracket is bolted to these steel lintels. As panels are slid into position, the steel rods sleeve into holes in the sides of the panels. Through the unsupported section of the roof, threaded rods run through entire panels and terminate in the perimeter structure of the adjacent panel. This occurs at two locations per panel. This effectively pulls the panels together, ensuring that they act as a single diaphragm. Lastly, the base and capital of the columns are bolted into the face of both the floor and roof panels, to stabilize them relative to each other.

Like the floor panels, the roof panels are craned off of the same roll-tite truck using eyelet bolts. Before being placed in their final position, they are craned onto the ground where the roof racking upstands can be installed. These will receive the roof racking steel installed in the next step, and also serve as fall-arrest tie-offs for workers on the roof who are guiding the panels into place.

After the first panel is placed the first column can be installed. The column is slid into place horizontally, allowing the base of the column to be concealed below the finished flooring.

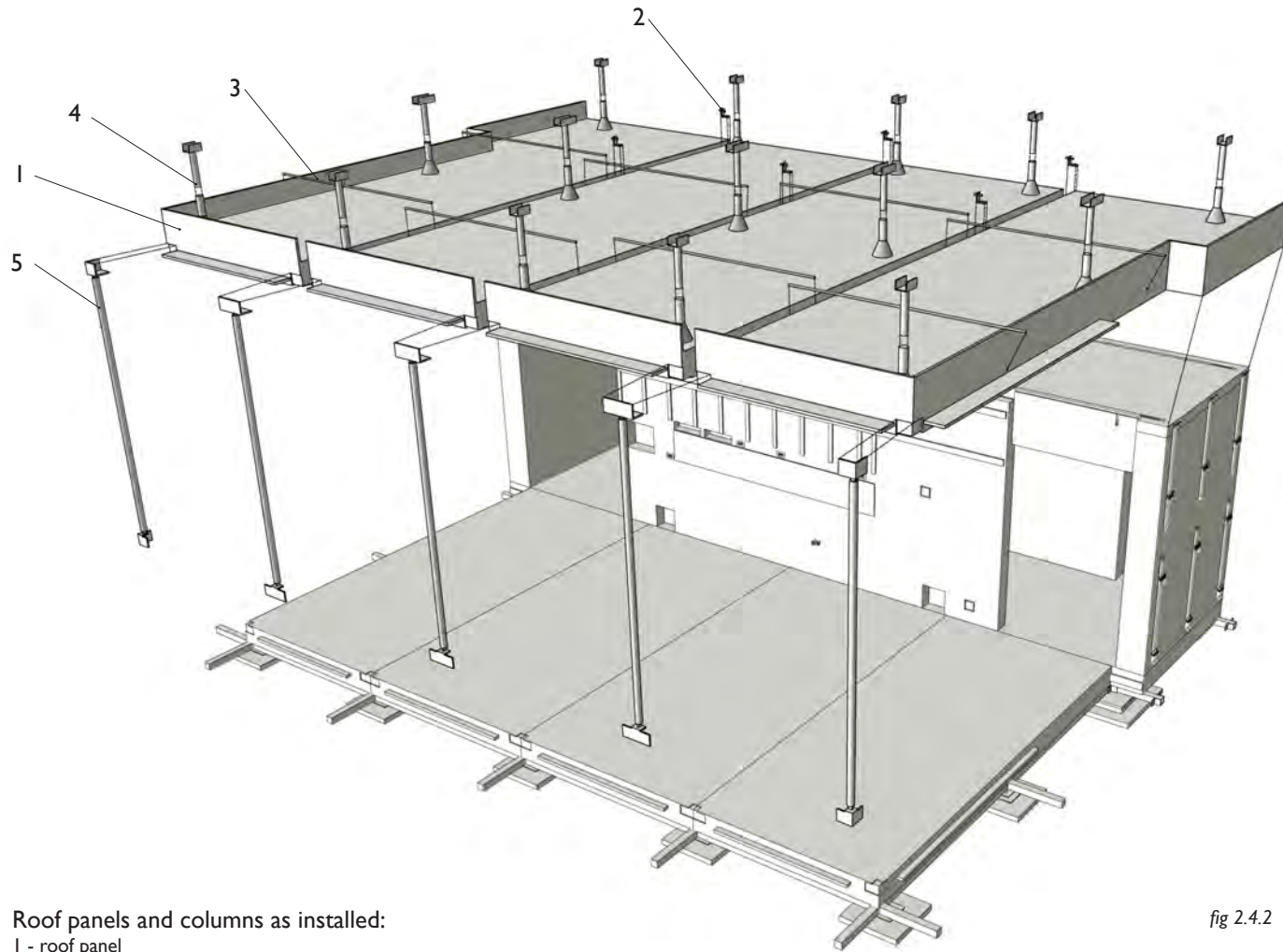
STEP 5: ROOF RACKING



Components placed during this step:

- 1 - 4 roof panels
- 2 - 6 angle brackets with steel rods
- 3 - 8 threaded rods
- 4 - 15 roof racking upstands
- 5 - 5 steel columns

fig 2.4.1



Roof panels and columns as installed:

- 1 - roof panel
- 2 - steel rod welded to angle bracket
- 3 - threaded rod
- 4 - roof racking upstand
- 5 - steel column

fig 2.4.2

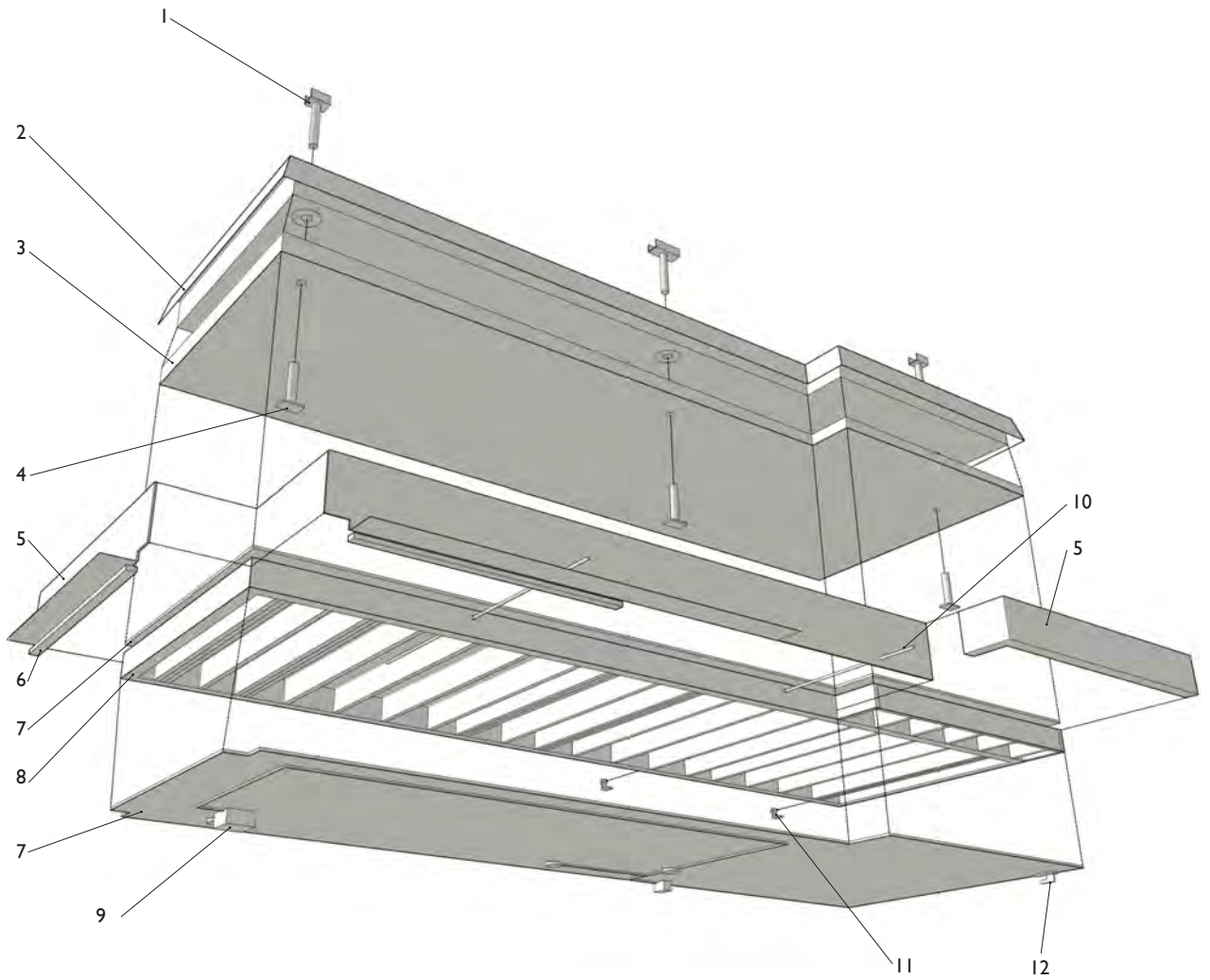


fig 2.4.3

Composition of Roof Panels

- 1 - roof racking upstand
- 2 - PVC roofing membrane
- 3 - sloped insulation
- 4 - steel upstand sleeve
- 5 - brakeform steel upstand
- 6 - Douglas fir blocking for fastening mullion frames
- 7 - plywood sheathing
- 8 - wood framing and spray foam insulation
- 9 - electrical rough in (for lights and interior blinds)
- 10 - threaded rod (connects roof panels together)
- 11 - steel angle bracket with steel rod (connects roof panels together and to densepack)
- 12 - steel hook (connects roof panels to densepack)

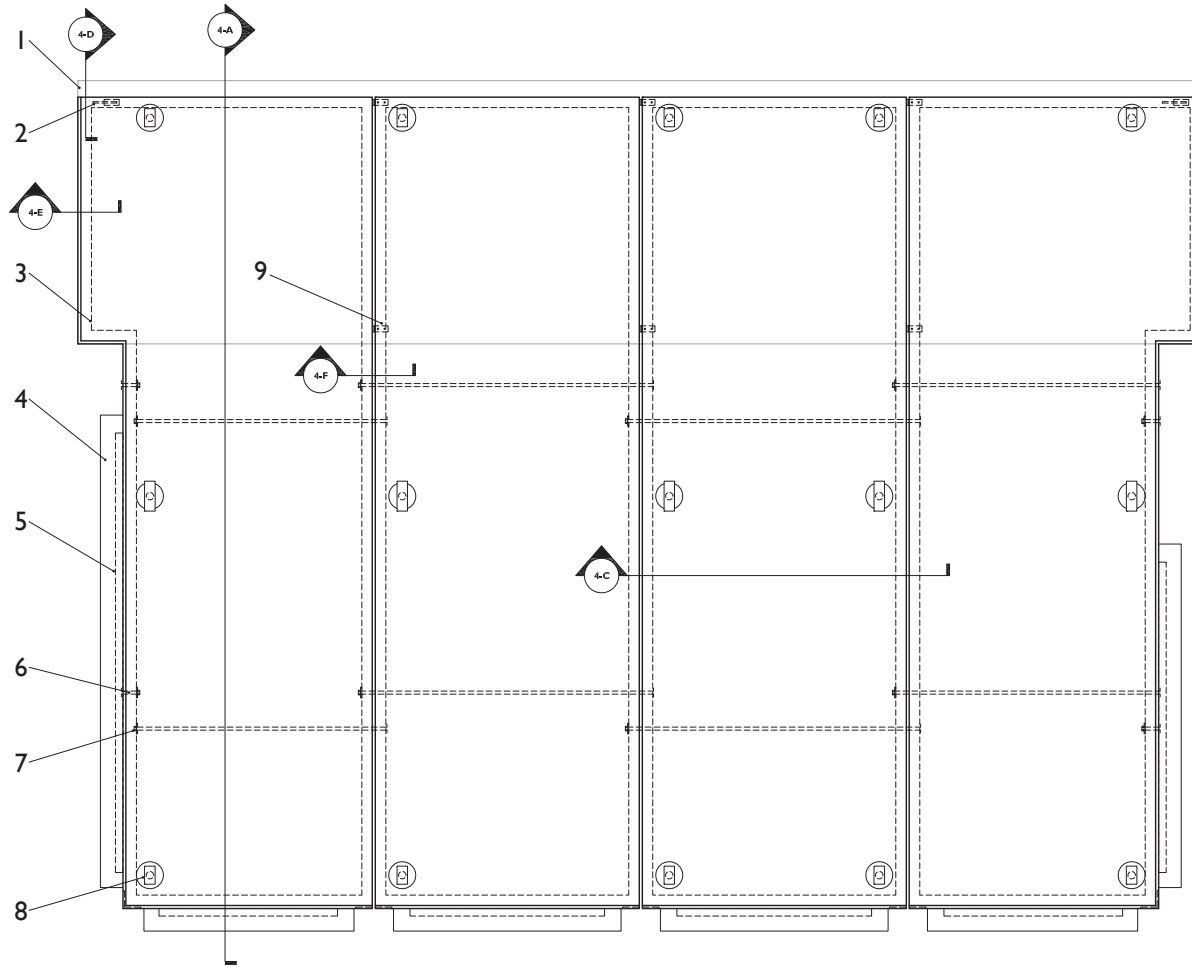


fig 2.4.4 Roof

- 1 - densepack below (shown for reference)
- 2 - steel hook preinstalled on roof panel (locked into steel lintel embedded in densepack ceiling)
- 3 - perimeter structure of roof panels
- 4 - brakeform steel upstand
- 5 - Douglas fir blocking for fastening mullion frames
- 6 - nut to receive craning eyelets
- 7 - nuts & conduit to receive threaded rods
- 8 - roof racking upstand
- 9 - steel angle bracket with steel rod between roof panels

fig 2.4.5 placing the roof panels



fig 2.4.6 temporary support beam used while placing roof panels



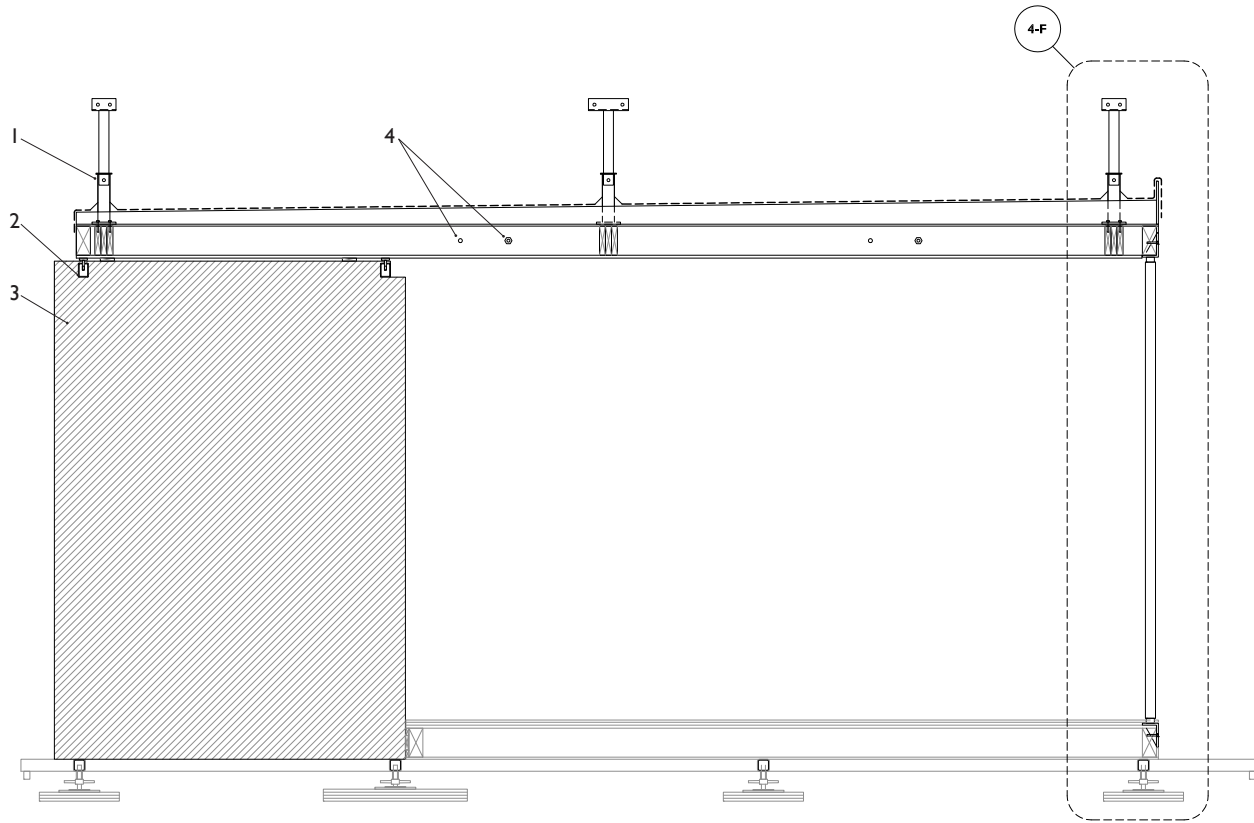


fig 2.4.7 Section

- 1 - bolted connection between upstand sleeve (preinstalled in roof panel) and roof racking upstand
- 2 - steel lintel embedded in ceiling structure of densepack
- 3 - densepack shown for reference, hatched
- 4 - preinstalled nuts and conduit to received threaded rods
- 5 - bolted connection to roof racking upstand
- 6 - upstand sleeve preinstalled in roof panel
- 7 - bolted connection between column capital and perimeter structure (of roof panel)
- 8 - bolted connection between column base and perimeter structure (of floor panel)

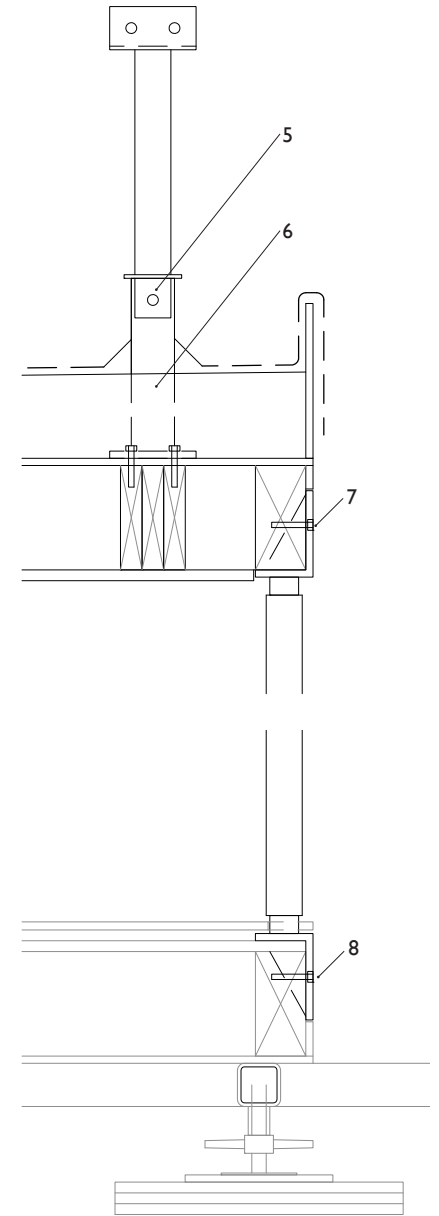


fig 2.4.8 Section

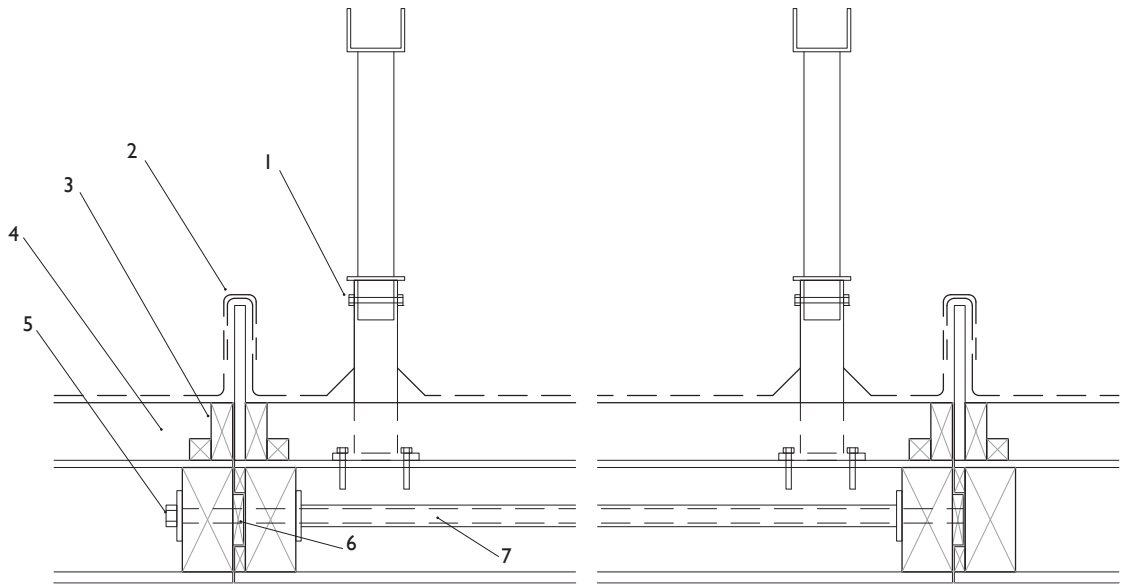


fig 2.4.9 Section

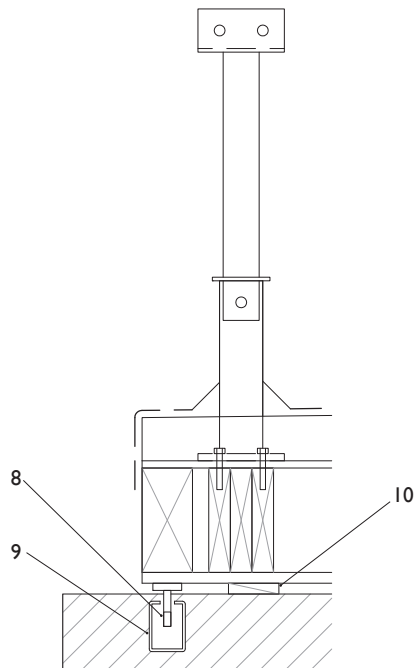


fig 2.4.10 Section Detail 4-D

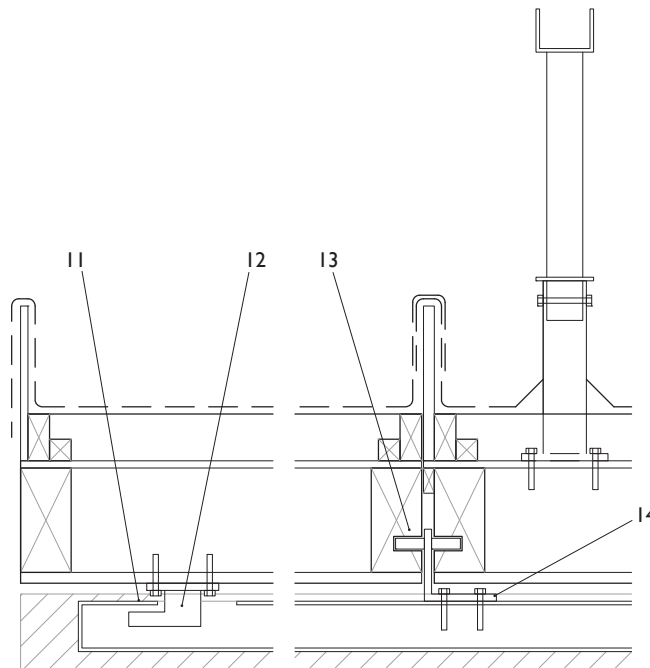


fig 2.4.11 Section Detail 4-E

fig 2.4.12 Section Detail 4-F

- 1 - bolted connection between upstand sleeve and roof racking upstand
- 2 - PVC roofing lapped over plywood upstand
- 3 - wood blocking as edging to sloped insulation
- 4 - sloped insulation
- 5 - preinstalled nut to receive threaded rod
- 6 - tongue and groove connection between roof panels
- 7 - conduit preinstalled in roof panel to receive threaded rod
- 8 - steel hook preinstalled on roof panel
- 9 - steel lintel embedded in densepack ceiling
- 10 - wood shim between roof panel and densepack
- 11 - steel lintel embedded in densepack ceiling
- 12 - steel hook preinstalled on roof panel
- 13 - angle bracket with steel rod inserted into sleeves in perimeter structure of roof panels
- 14 - bracket bolted to steel lintel

fig 2.4.13 tightening the threaded rods



fig 2.4.14 angle bracket between roof panels



The next step is to install the steel sections that make up the roof racking system. This consists primarily of five structural roof racking frames running north-south and, on top of these, HSS purlins running east-west. This system supports the solar panels, BIPV cladding panels, solar thermal collectors, inverters, heat dissipaters, weather sensors, and exterior venetian blinds as well as wiring bundles for all exterior electrical components.

This system was designed to be independent of the insulated building envelope below. The only connection between the roof racking system and the building below occurs at the sleeved and bolted joint at each of the fifteen roof racking upstands. Not only does this give the roof racking system spatial independence, it also creates a two-and-a-half foot high clear space between the solar panels and the insulated roof assembly. This allows for access to all the roof-mounted systems and ensures adequate air movement around the panels to prevent overheating.

Custom end brackets on both the roof racking frames and the purlins allow for the attachment of the exterior blind supports and the BIPV cladding supports.

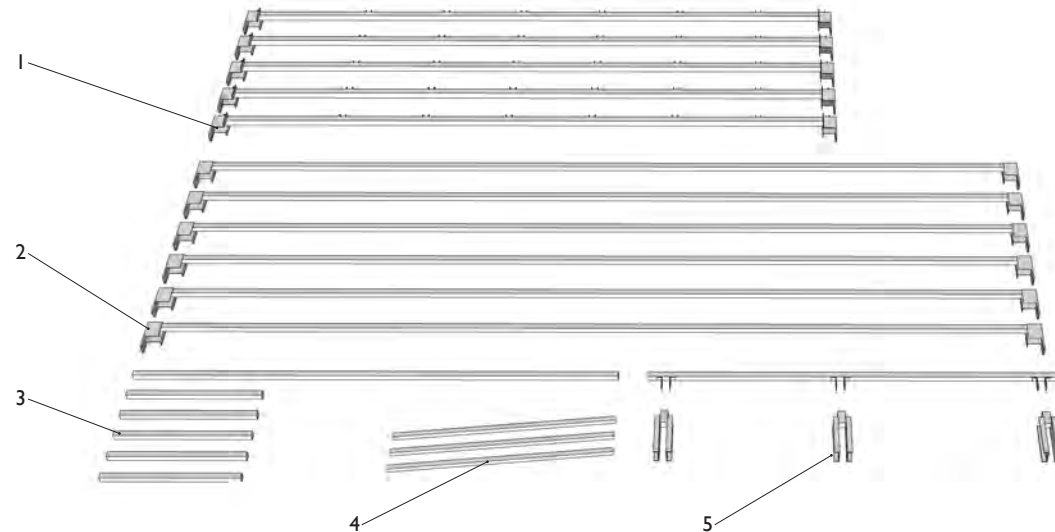
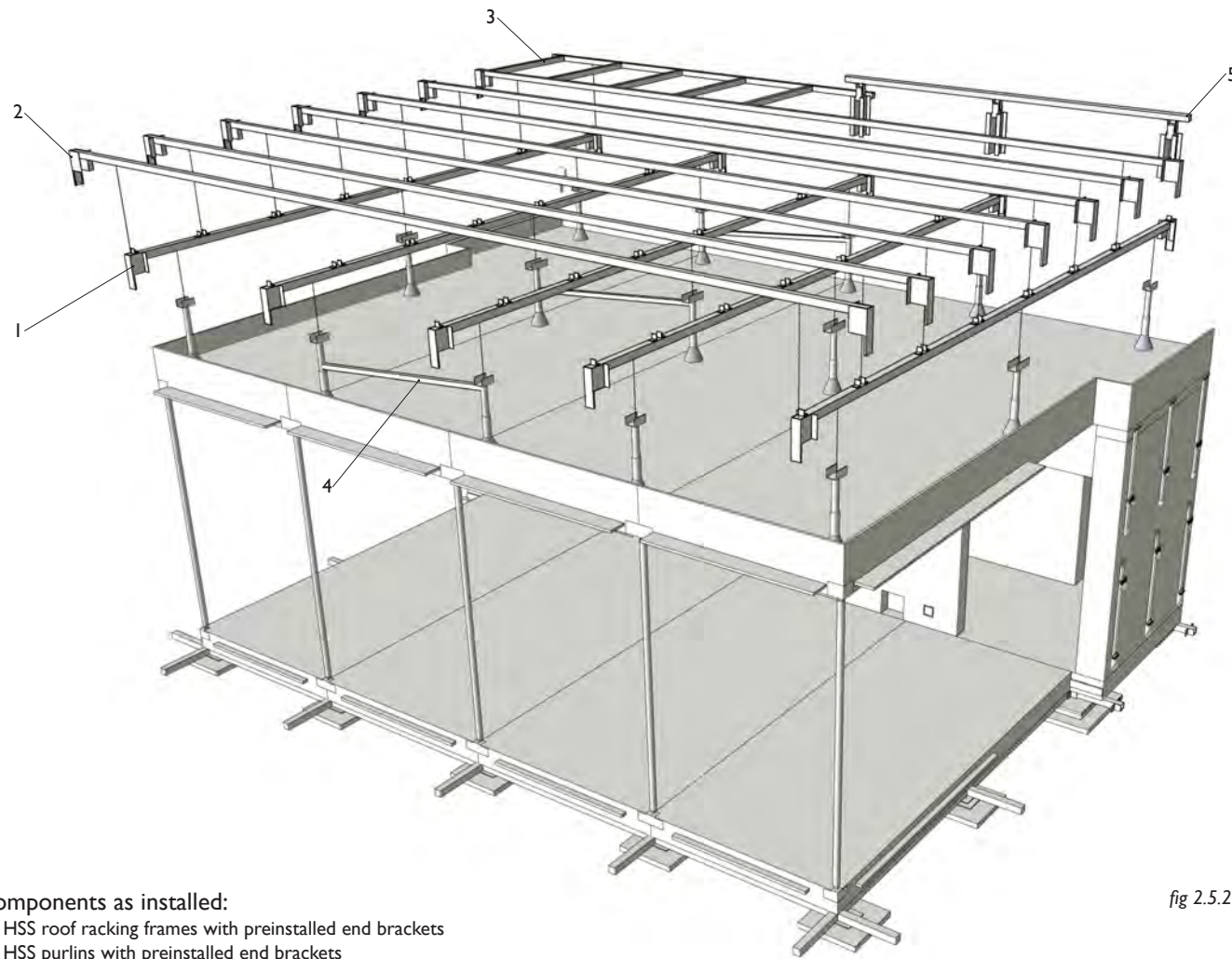


fig 2.5.1

Components placed during this step:

- 1 - 5 HSS roof racking frames with preinstalled end brackets
- 2 - 6 HSS purlins with preinstalled end brackets
- 3 - 6 short additional purlins
- 4 - 3 steel cross braces
- 5 - angled rack for solar-thermal collectors



Components as installed:

- 1 - HSS roof racking frames with preinstalled end brackets
- 2 - HSS purlins with preinstalled end brackets
- 3 - short additional purlins
- 4 - steel cross braces
- 5 - angled rack for solar thermal collectors

fig 2.5.2

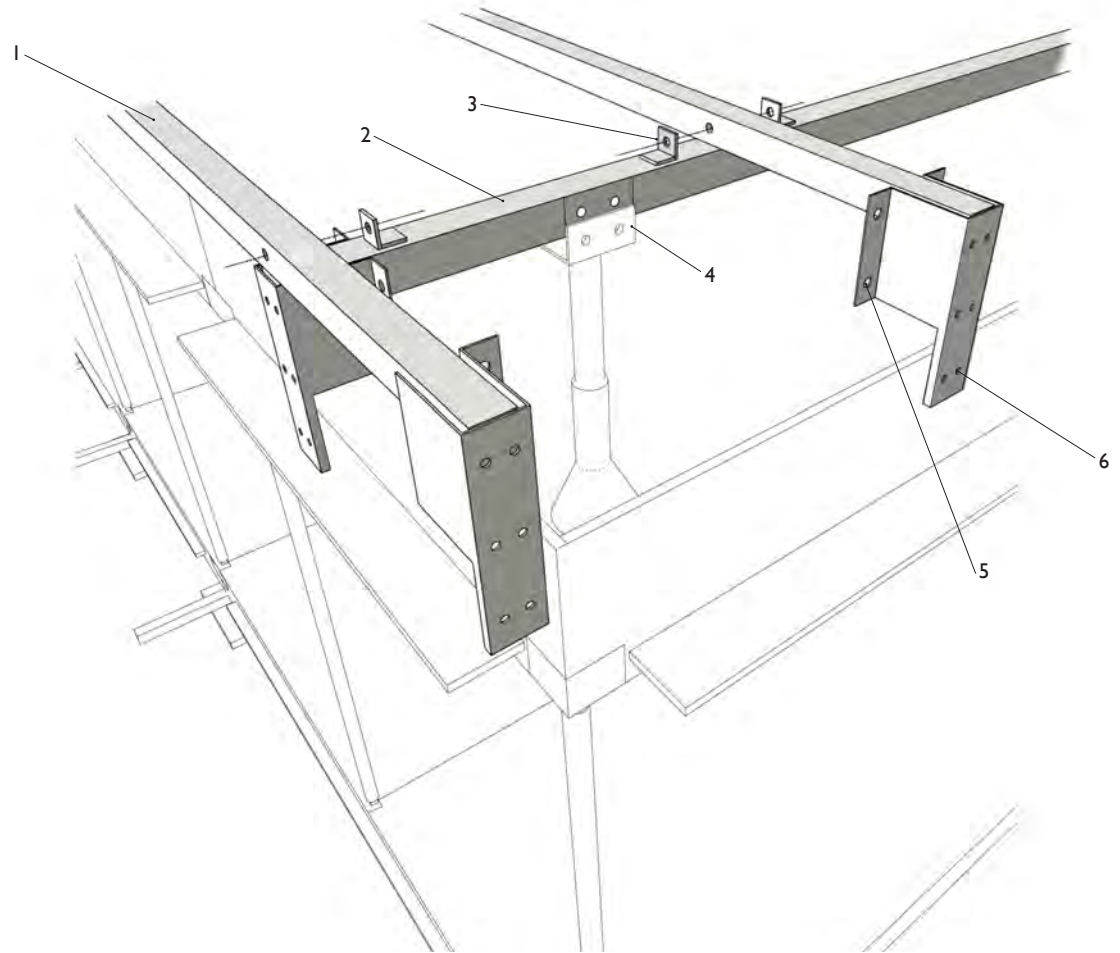


fig 2.5.3

Parts of Roof Racking Steel

- 1 - HSS purlin (holds solar panels and bears on roof racking frames)
- 2 - HSS roof racking frame
- 3 - brackets welded to roof racking frame provide bolted connection to purlins
- 4 - roof racking upstand, bolted to roof racking frame
- 5 - point of attachment for blind supports
- 6 - point of attachment for fascia cladding supports
(5 & 6 occur on brackets found at ends of both purlins and roof racking frames)

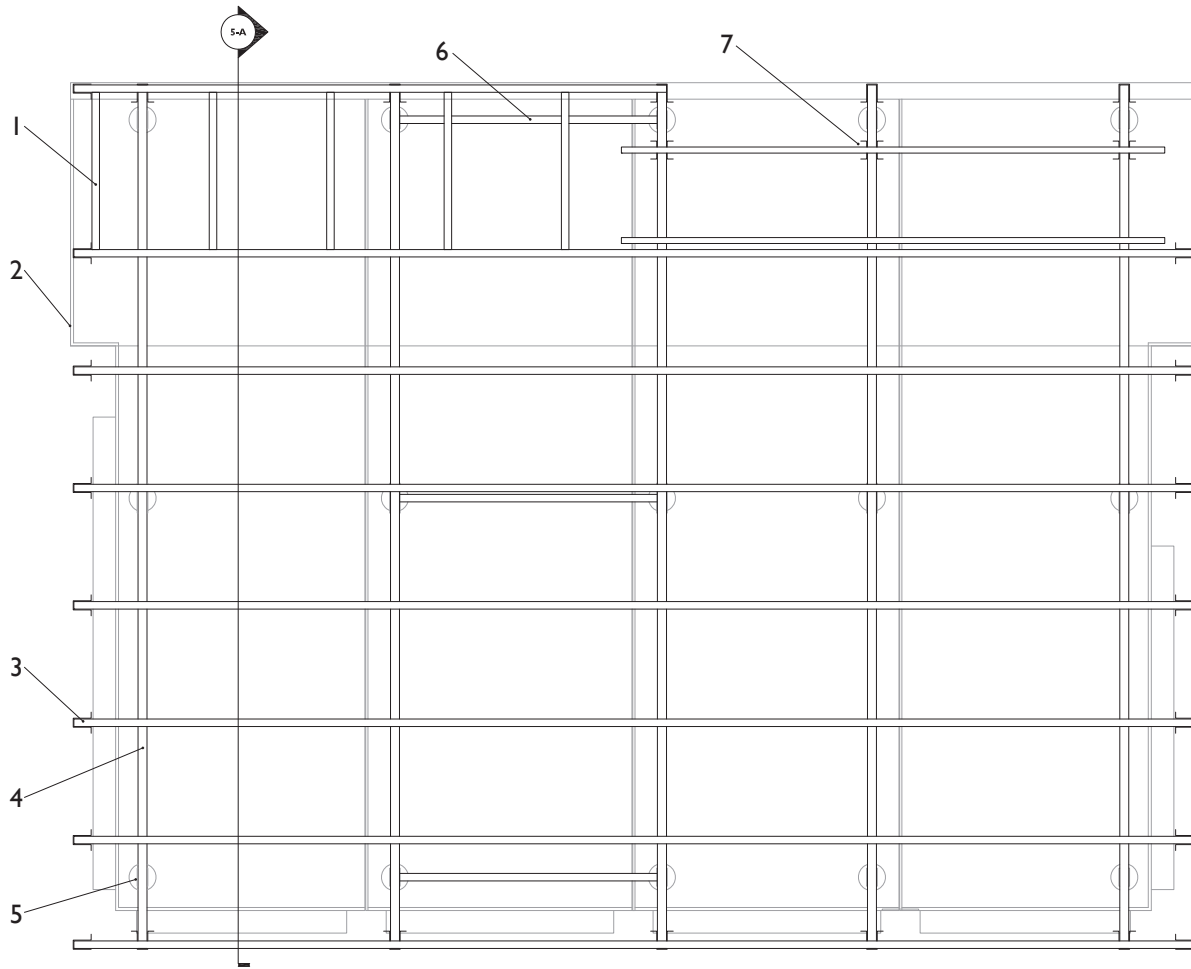


fig 2.5.4 Roof Steel Plan

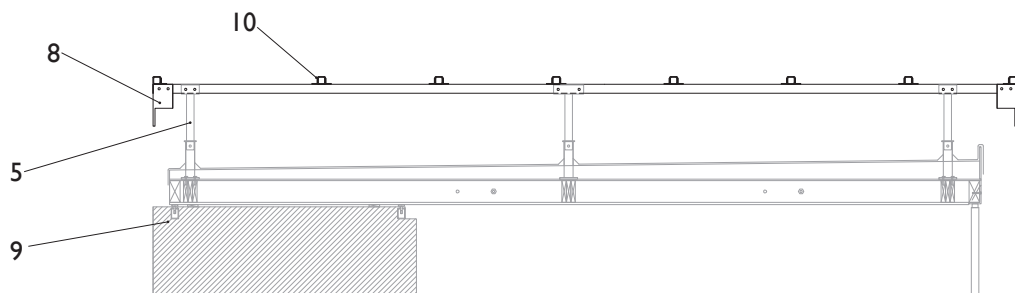


fig 2.5.5 Section 5-A

- 1 - additional short purlin (to hold solar panels)
- 2 - roof panels below (shown for reference)
- 3 - HSS purlin
- 4 - HSS roof racking frame
- 5 - roof racking upstand (shown for reference)
- 6 - steel cross bracing
- 7 - angled rack for solar thermal collectors
- 8 - end bracket on roof racking frame
- 9 - building below (shown for reference)
- 10 - brackets welded to roof racking frame hold purlins

fig 2.5.6 placing the first roof racking frame



fig 2.5.7 corner showing end brackets on roof racking frames and purlins



STEP 6: MULLION FRAMES

The height of the Douglas-fir mullion frames requires them to be disassembled for shipping.

The individual mullions must first be assembled into three frames, one for each glazed façade. Brakeform steel inserts are pre-installed on all vertical mullions and interlock with a friction fit rubber cap once the IGUs are in place. It is important to note that these inserts were fabricated in steel solely because of time constraints, and in order for the building to perform as designed in a cold climate in winter, would need to be replaced with a thermally inert material such as fibreglass or high-density plastic.

Douglas-fir blocking installed on the edges of the floor and roof panels provide a guide for correctly positioning the frames, and frames are mechanically fastened to this blocking.

The insulated ventilation panels and door frames are installed after the mullion frames.

fig 2.6.1 connecting vertical and horizontal mullions



fig 2.6.2 Mullions disassembled for shipping

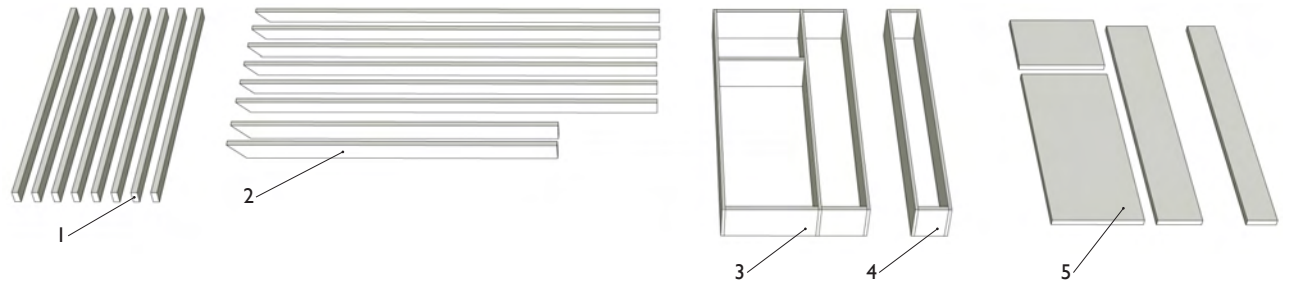
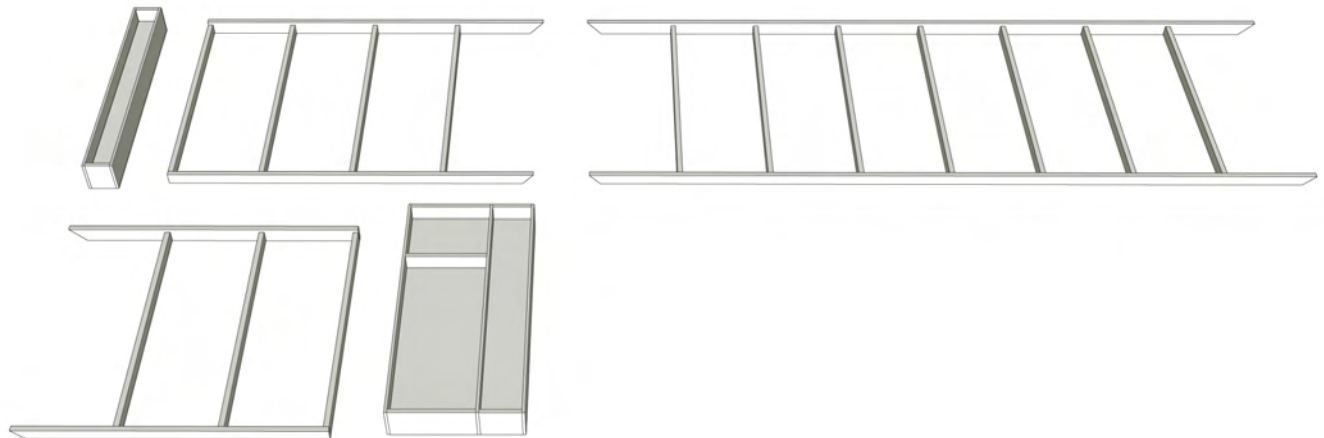
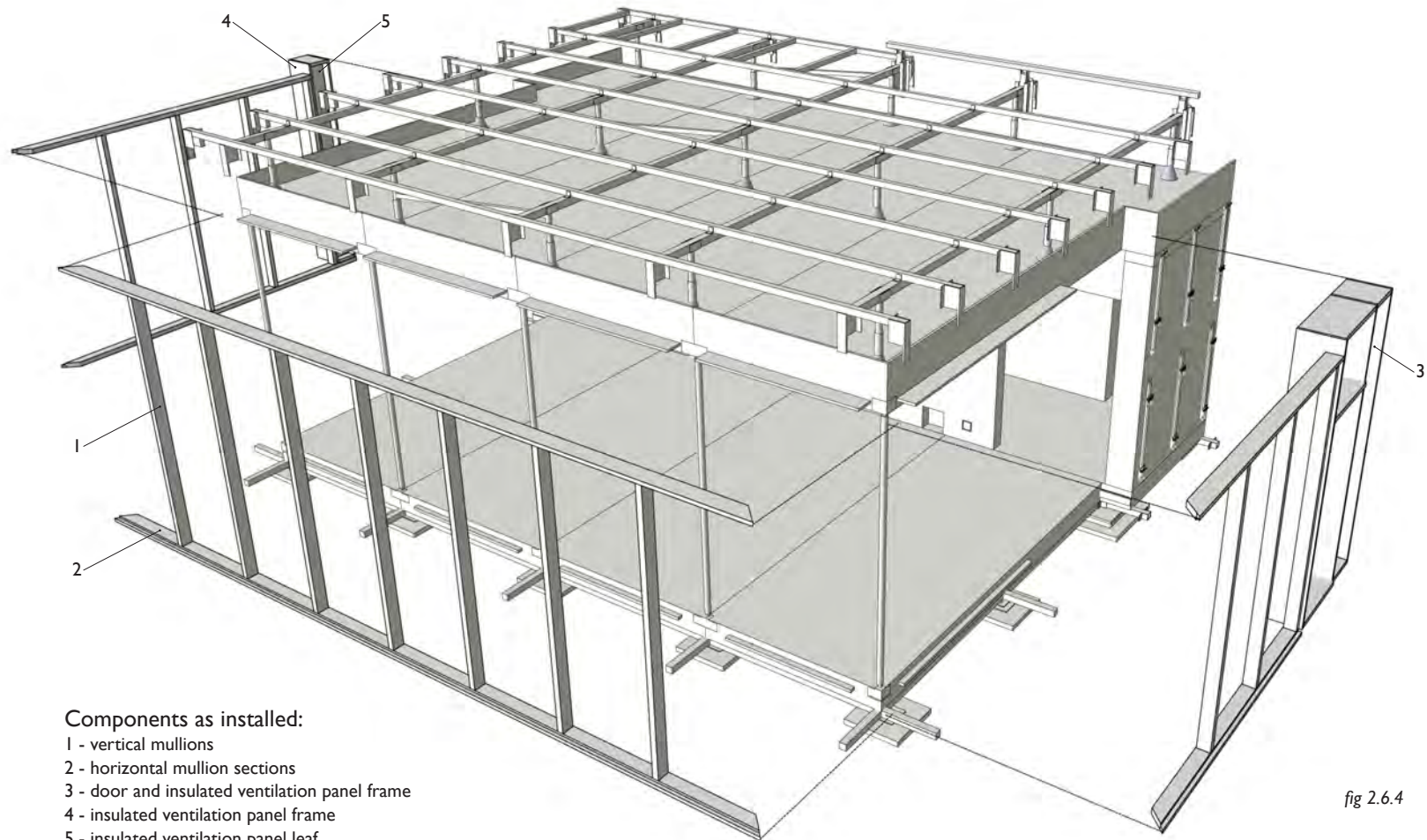


fig 2.6.3 Mullions assembled into frames



Components placed during this step:

- 1 - 14 vertical mullions (with glazing tape and brakeform steel inserts pre-installed)
- 2 - 8 horizontal mullion sections (with glazing tape pre-installed)
- 3 - 1 door and insulated ventilation panel frame
- 4 - 1 insulated ventilation panel frame
- 5 - insulated door & ventilation panel leaves (4 pieces)



Components as installed:

- 1 - vertical mullions
- 2 - horizontal mullion sections
- 3 - door and insulated ventilation panel frame
- 4 - insulated ventilation panel frame
- 5 - insulated ventilation panel leaf

fig 2.6.4

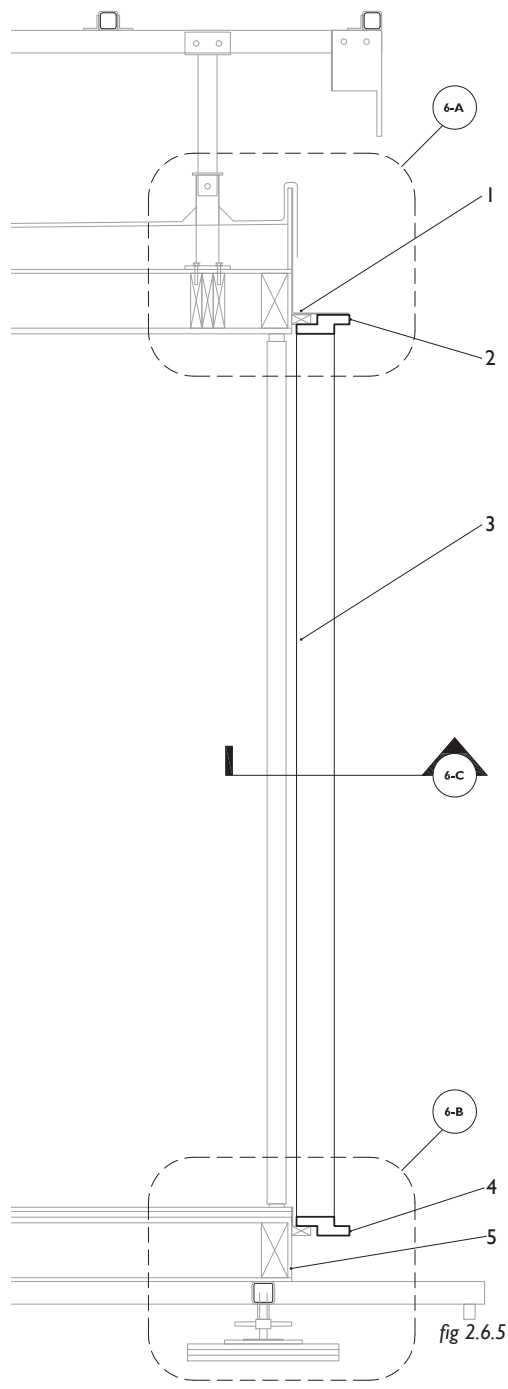


fig 2.6.5

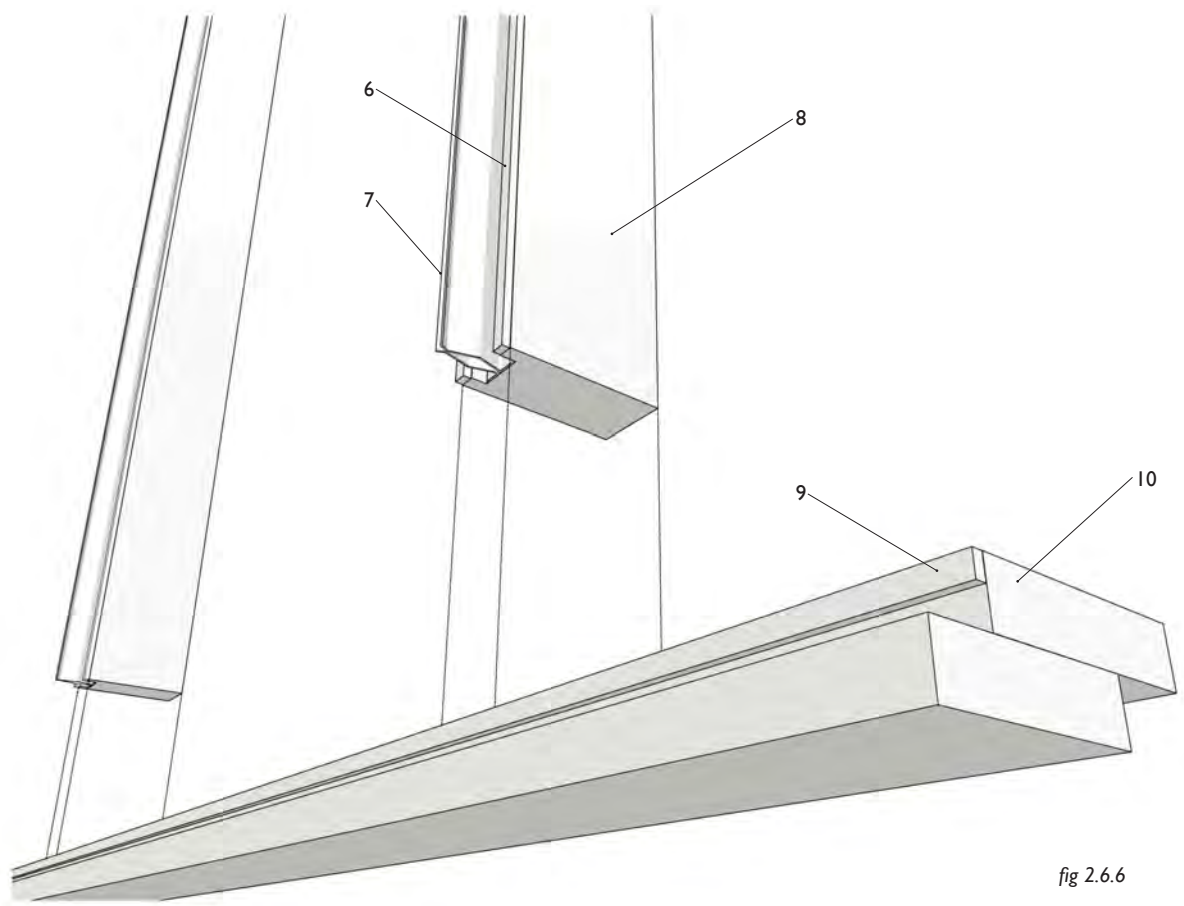


fig 2.6.6

- 1 - roof panel with wood blocking and brakeform steel upstand to receive mullion (shown for reference)
- 2 - horizontal head mullion (with glazing tape pre-installed)
- 3 - vertical mullion beyond
- 4 - horizontal sill mullion (with glazing tape pre-installed)
- 5 - floor panel with blocking to receive mullion (shown for reference)
- 6 - glazing tape
- 7 - brakeform steel inserts
- 8 - Douglas fir-clad mullion (with pine core)
- 9 - glazing tape
- 10 - Douglas fir sill mullion

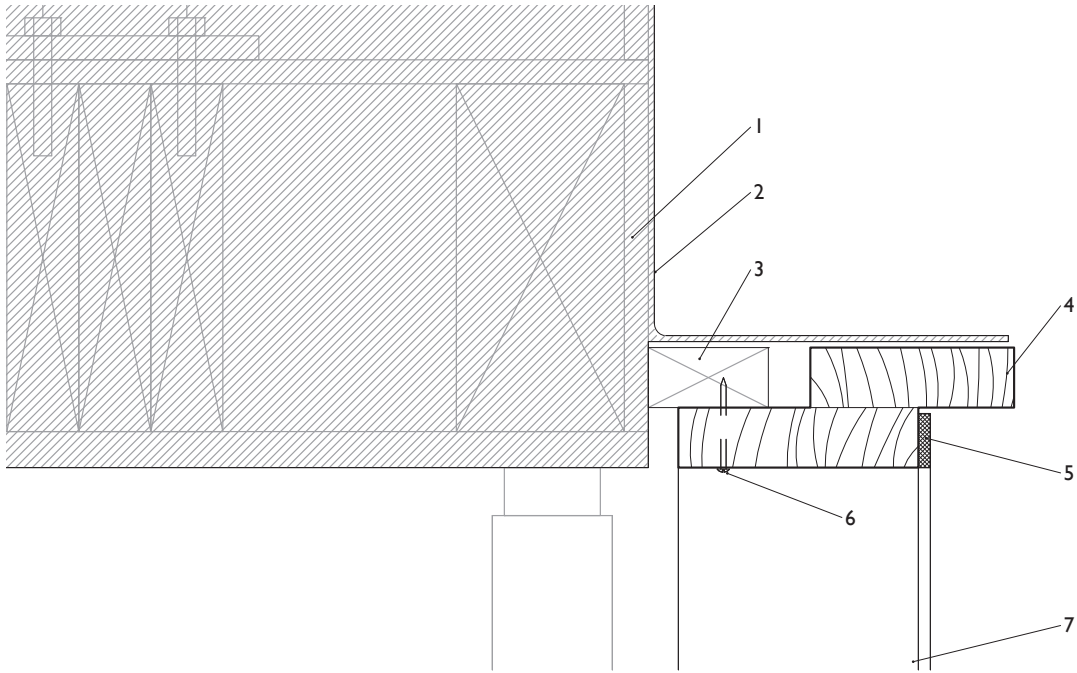


fig 2.6.7 Section Detail 6-A

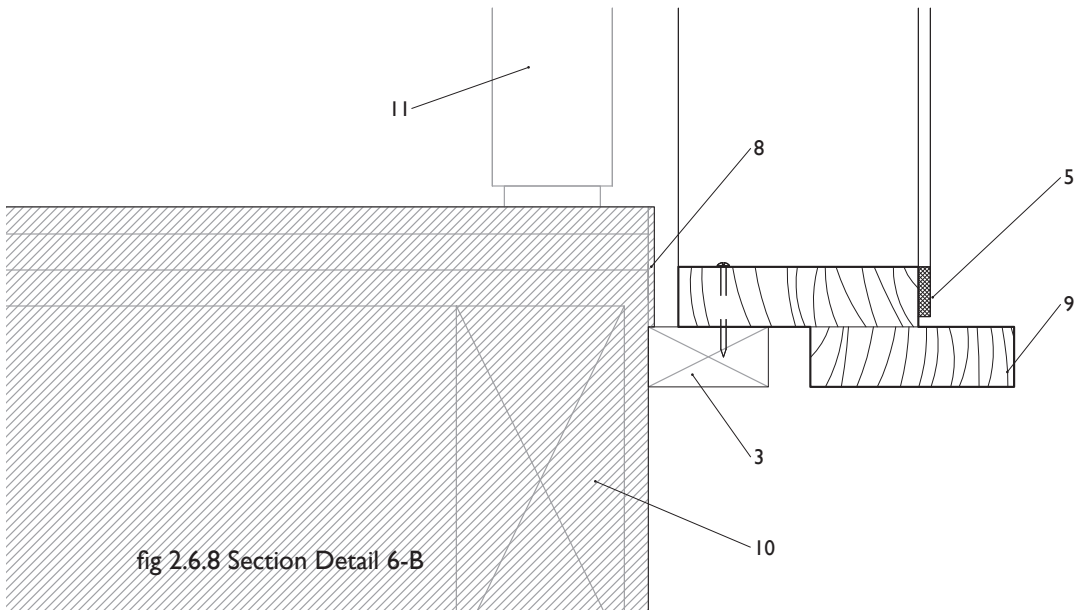


fig 2.6.8 Section Detail 6-B

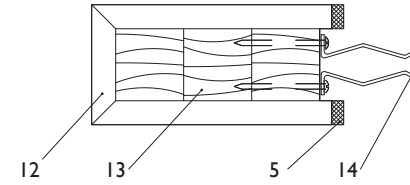


fig 2.6.9 Plan Detail 6-C

- 1 - roof panel (shown for reference)
- 2 - brakeform steel upstand to receive mullions
- 3 - Douglas fir blocking to receive mullion frames
- 4 - horizontal head mullion
- 5 - pre-installed glazing tape
- 6 - fastener
- 7 - vertical mullion beyond
- 8 - stainless steel edging (must be completely installed before mullions)
- 9 - horizontal sill mullion
- 10 - floor panel (shown for reference)
- 11 - column beyond (shown for reference)
- 12 - edge sawn Douglas fir
- 13 - pine core
- 14 - pre-installed brakeform steel inserts (fastened to core of mullion)

fig 2.6.10 The North House with mullions installed



STEP 7: BASE SUPPORT FRAME

The base support frame consists of steel framing channels that are fastened to the sides of the floor panels that support the glazing system, and provide a point of anchorage for the tension stays of the exterior blinds.

At the corners, where the glazing system is cantilevered, additional support is required. Hollow steel sections with welded brackets are installed between the sill mullions and the steel substructure below. They are fastened to the steel substructure, leaving a gap under the mullions. This gap provides a shim space that can be used to level the glazing system and ensure that it is properly supported.

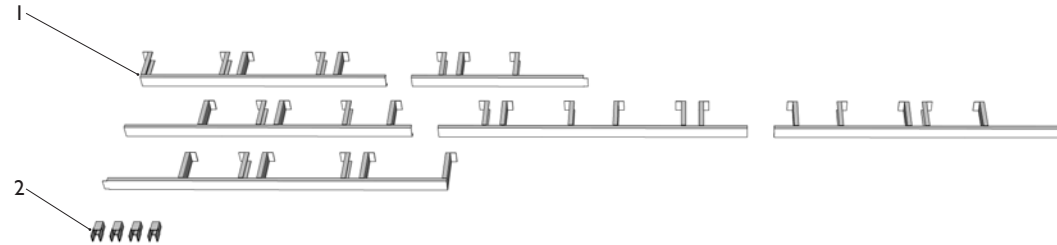
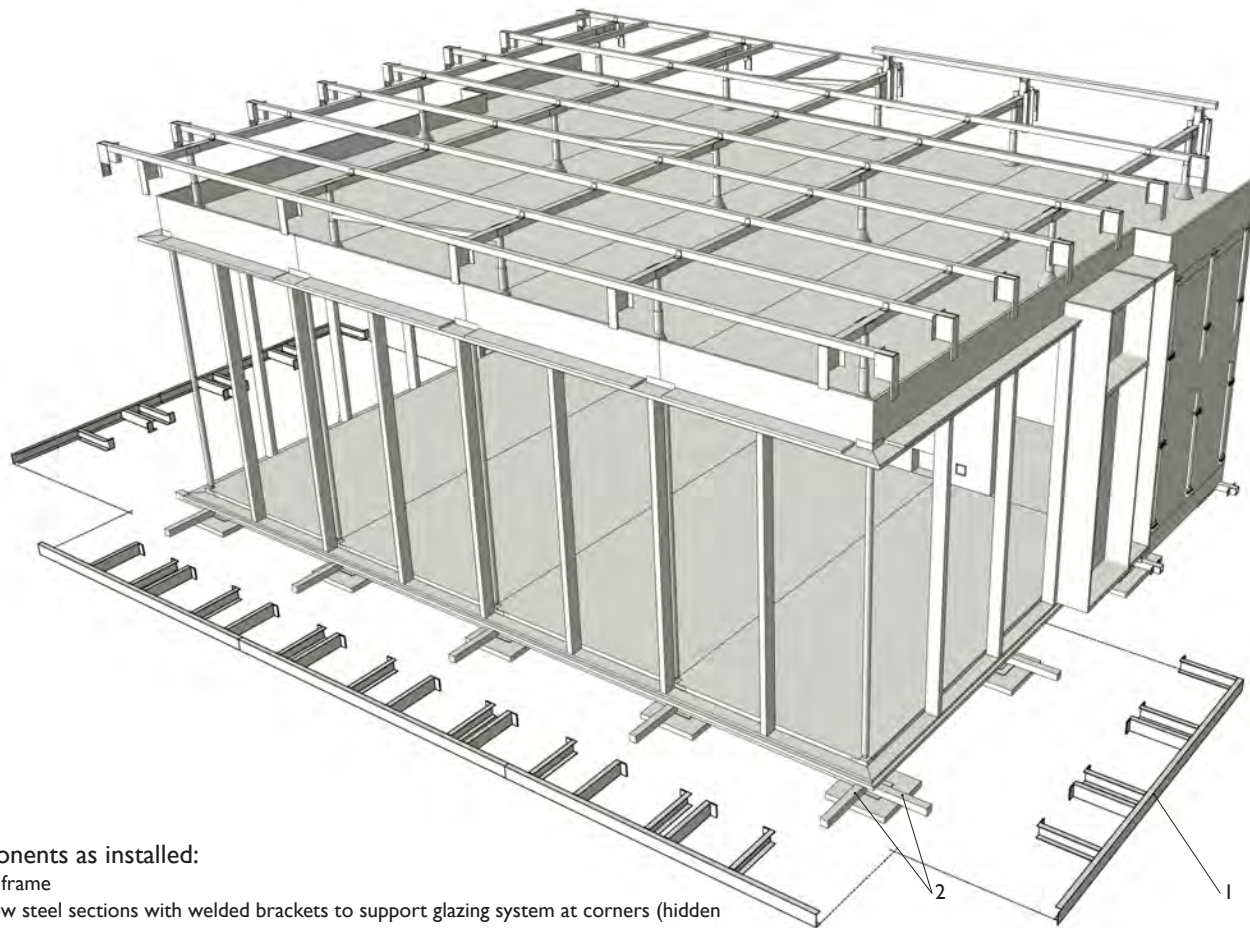


fig 2.7.1

Components placed during this step:

- 1 - 6 base support segments (includes preinstalled brackets for exterior blind tension stays)
- 2 - 4 hollow steel sections with brackets to support glazing system at corners

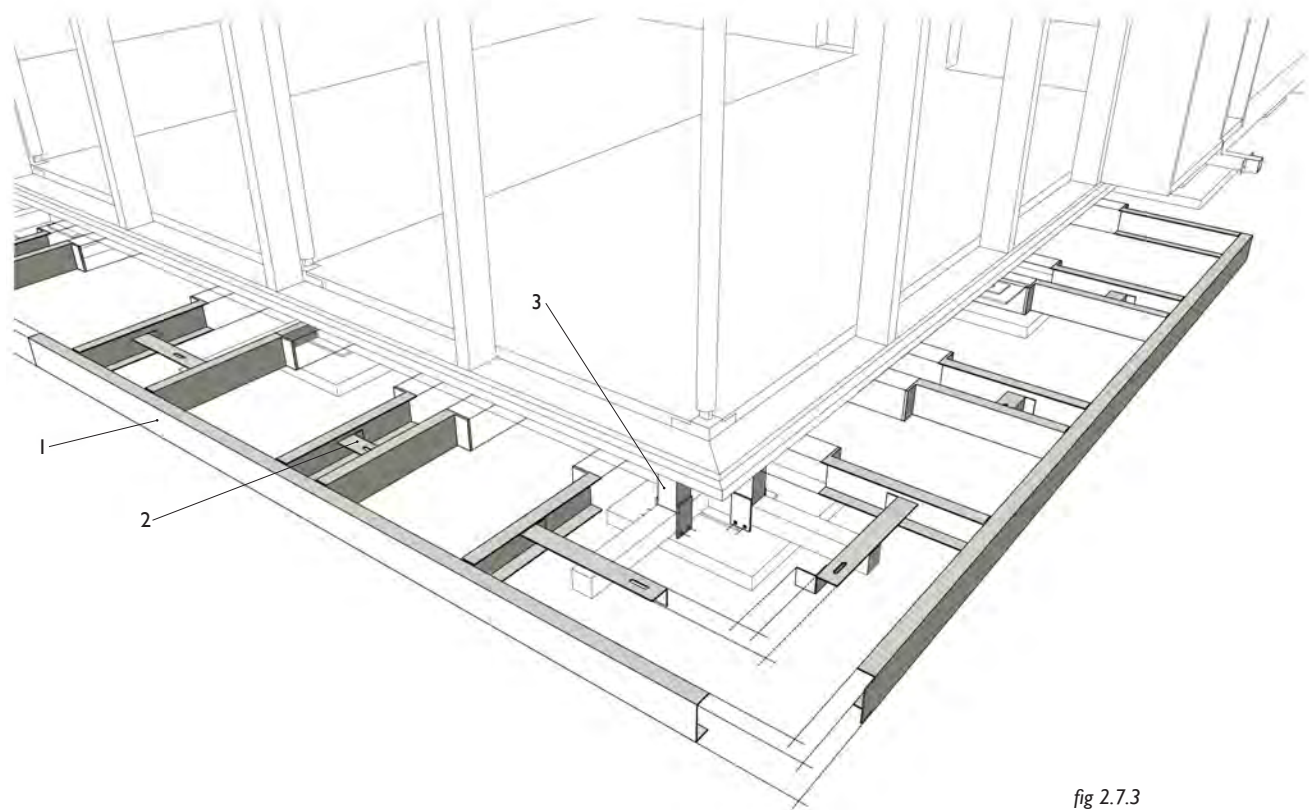


Components as installed:

1 - base frame

2 - hollow steel sections with welded brackets to support glazing system at corners (hidden below)

fig 2.7.2



Parts of Glazing Supports

- 1 - base support frame (composed of steel framing channel)
- 2 - brackets for exterior blind tension cables
- 3 - hollow steel section with welded brackets to support glazing system at corners

fig 2.7.3

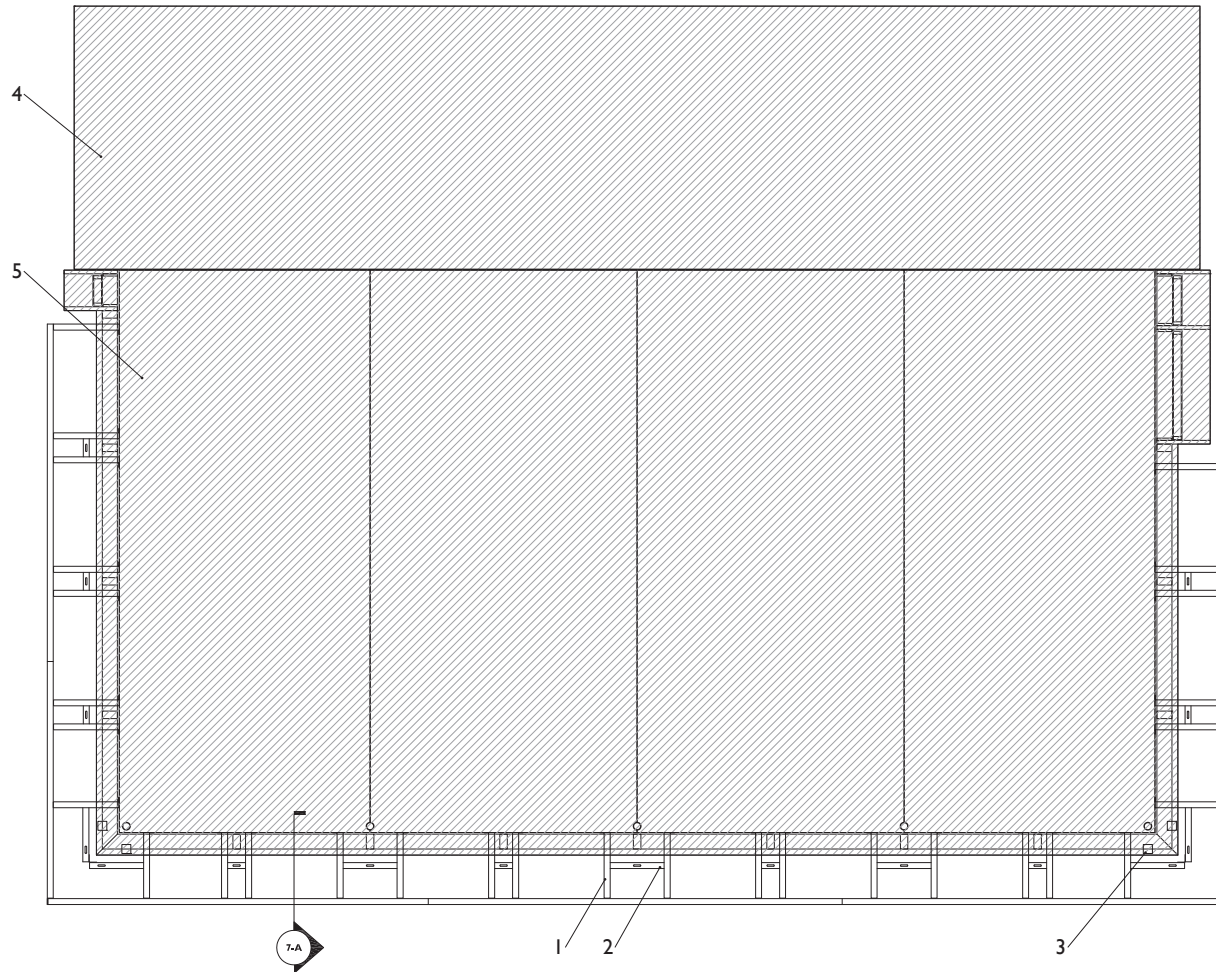


fig 2.7.4 Base Support Frame Plan

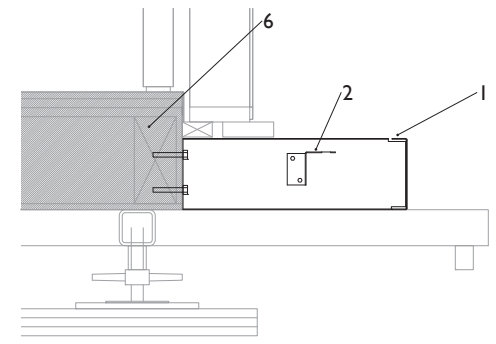
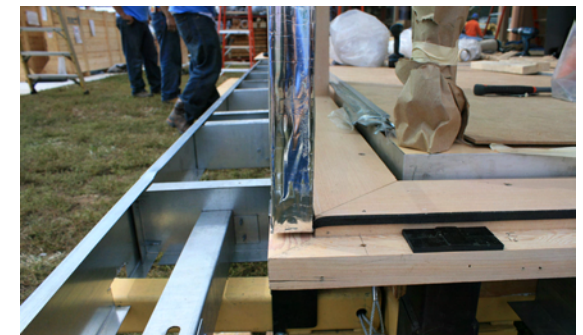


fig 2.7.5 Section Detail 7-A

- 1 - base support (composed of steel framing channel)
- 2 - brackets for exterior blind tension cables
- 3 - hollow steel section to support glazing system at corners
- 4 - densepack (shown for reference)
- 5 - floor panels, columns and mullions (shown for reference)
- 5 - floor panels (shown for reference)

fig 2.7.6 base supports at corner



STEP 8: IGUs & MULLION CAPS

The Insulated Glazing Units (IGUs) used for the North House are quad-layered units with semi-insulating spacers manufactured by Serious Materials Inc.. The units consist of two outer layers of glass and two inner Heat Mirror 88 films. All cavities are krypton filled. Standard units measure 9'-9 3/4" x 3'-7 1/2" and at 35 square feet are the maximum area of unit that can be manufactured using this spacer. By having as few units as possible, we have minimized the frame effect, meaning that the centre of glass R-value of 12.5 is only reduced to R-8 overall including frames.

The IGUs are held in place against the wood mullions using a fiberglass pressure plate at the head and sill, with a powder coated aluminum cover. Before the fiberglass pressure plates can be installed, the Blueskin peel-and-stick membrane that is pre-adhered to the roof panels must be lapped over the tops of the IGUs and onto the face of the glass where its edge will be held in place and concealed by the pressure plate. A friction fit rubber cap is installed at the face of each vertical joint and is held in place by the brakeform steel inserts pre-installed on the vertical mullions.

Lastly, the nylon corner inserts can be installed and fastened in place with two powder coated aluminum angles that overlap the edges of the corner IGUs.

fig 2.8.1 The North House with glazing installed

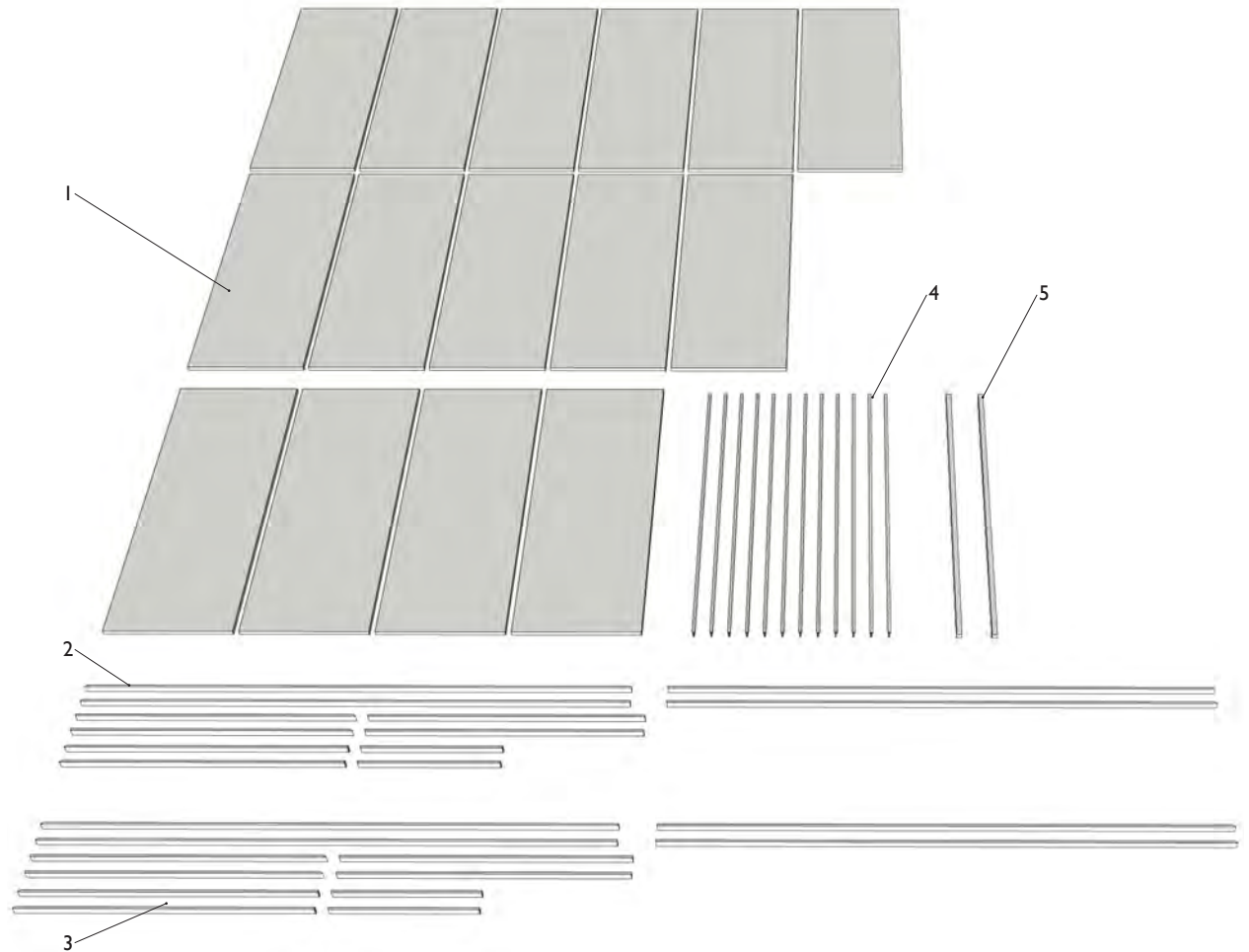
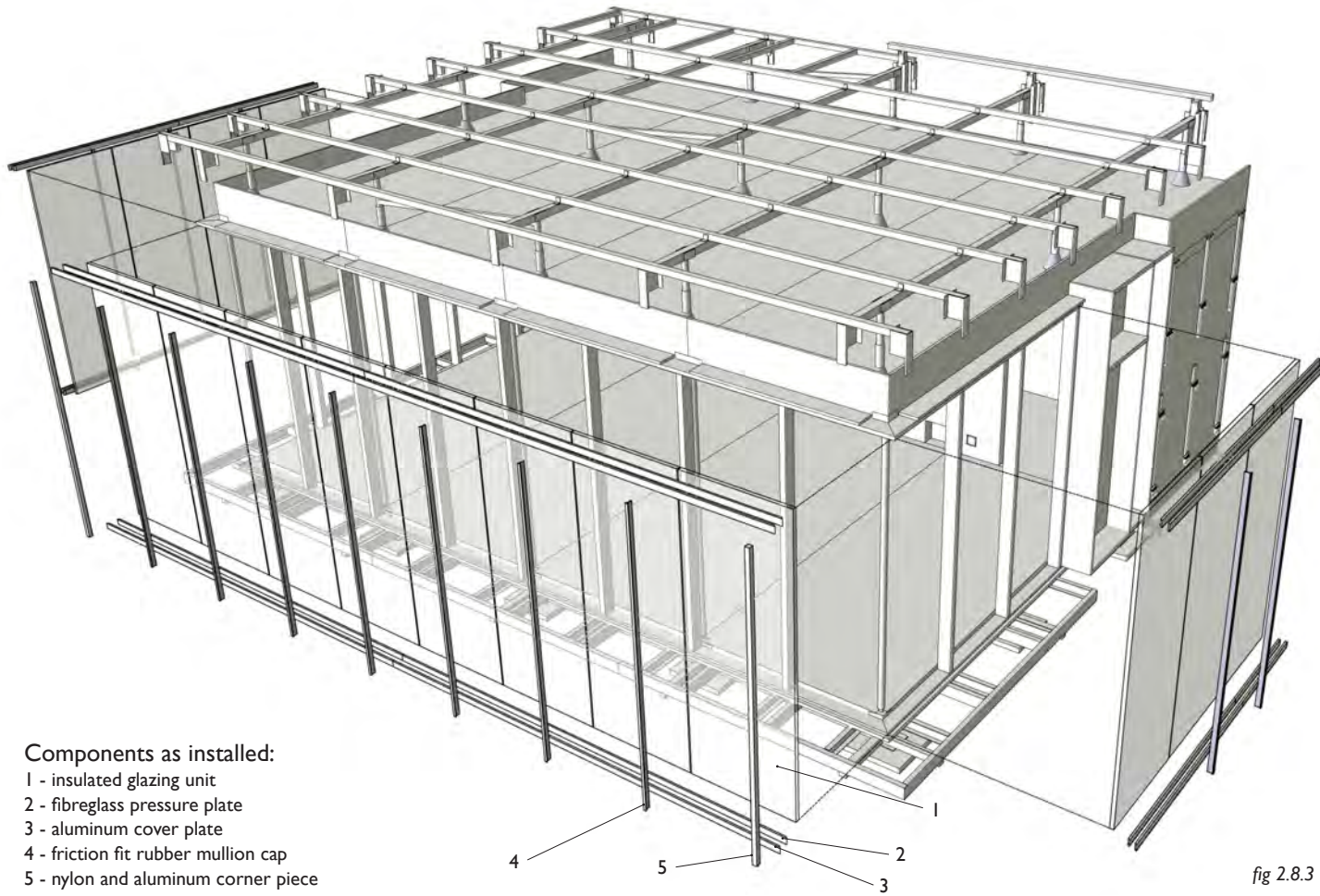


fig 2.8.2

Components placed during this step:

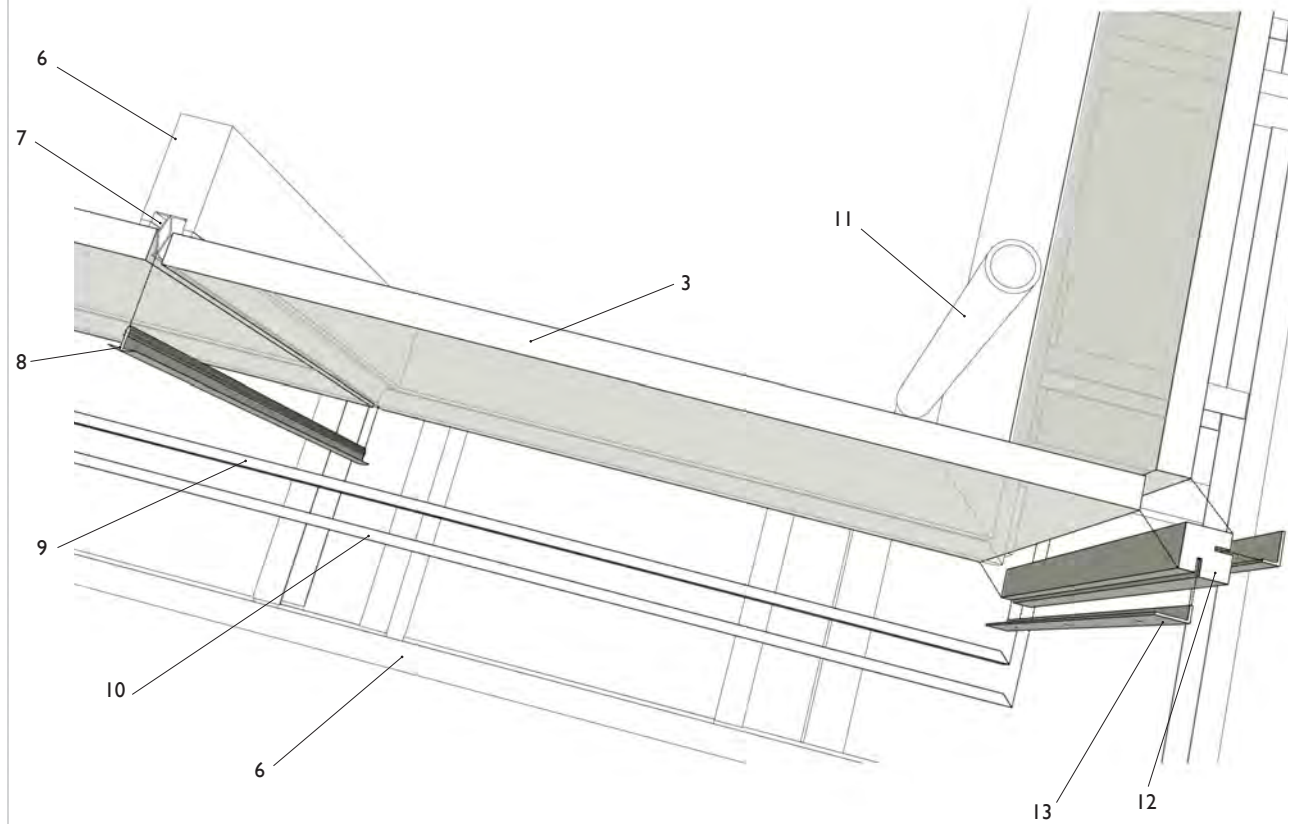
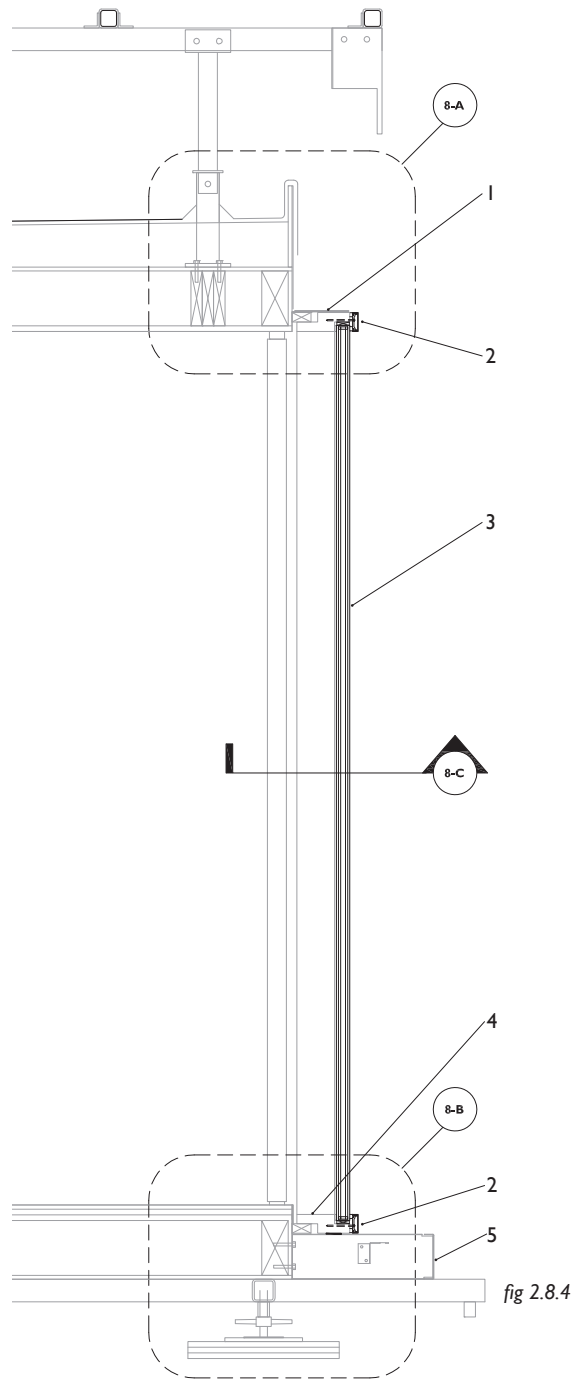
- 1 - insulated glazing units (15 pieces)
- 2 - fiberglass pressure plates (12 pieces)
- 3 - aluminum cover plates (12 pieces)
- 4 - 12 friction fit rubber mullion caps
- 5 - 2 nylon and aluminum corner pieces



Components as installed:

- 1 - insulated glazing unit
- 2 - fibreglass pressure plate
- 3 - aluminum cover plate
- 4 - friction fit rubber mullion cap
- 5 - nylon and aluminum corner piece

fig 2.8.3



- 1 - head mullion (shown for reference)
- 2 - fibreglass pressure plate and aluminum cap
- 3 - insulated glazing unit
- 4 - sill mullion (shown for reference)
- 5 - base support frame (shown for reference)
- 6 - vertical mullion (shown for reference)
- 7 - brakeform stainless steel inserts (to receive friction fit rubber mullion cap)

- 8 - friction fit rubber mullion cap
- 9 - fibreglass pressure plate
- 10 - aluminum cover plate
- 11 - column (shown for reference)
- 12 - milled nylon corner insert
- 13 - powder coated aluminum angle

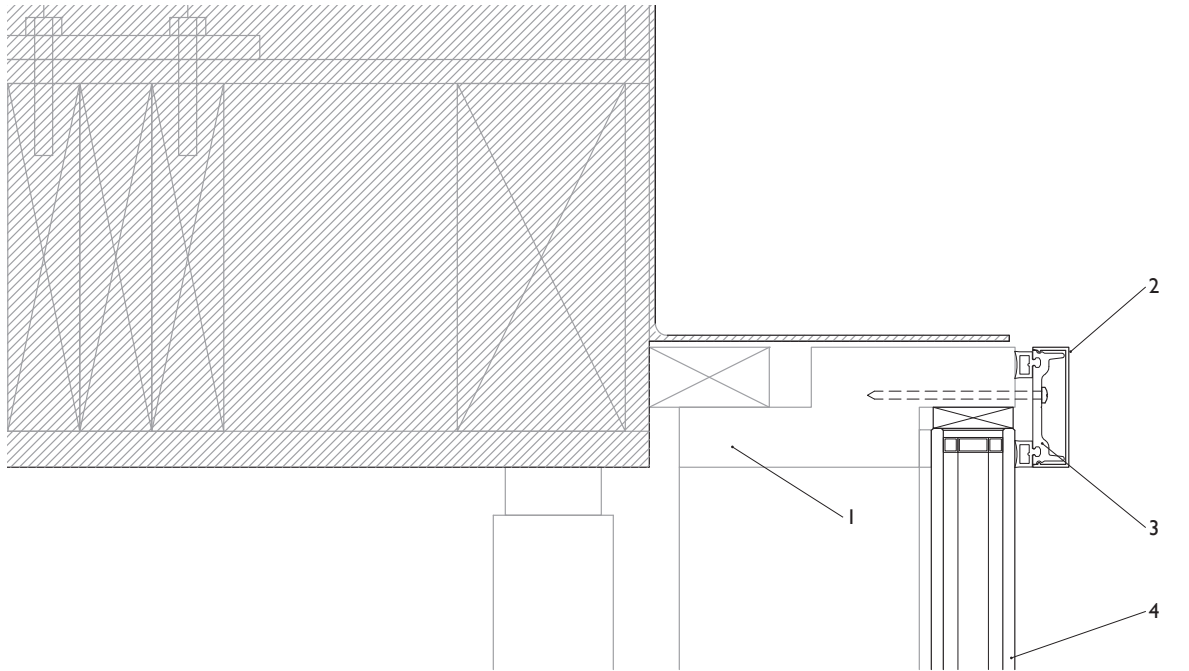


fig 2.8.6 Section Detail 8-A

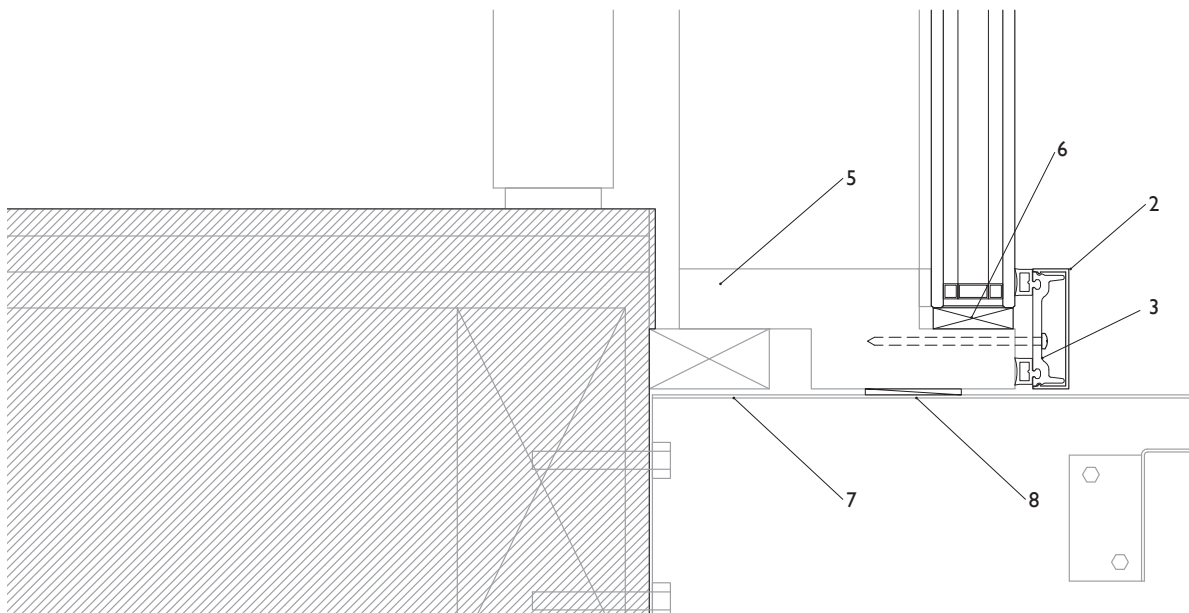


fig 2.8.7 Section Detail 8-B

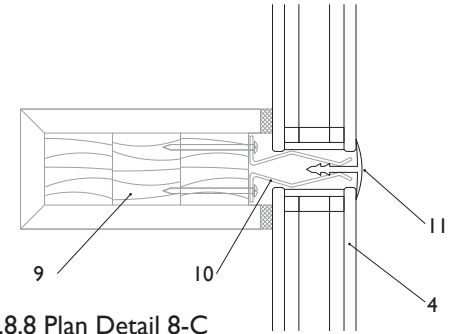


fig 2.8.8 Plan Detail 8-C

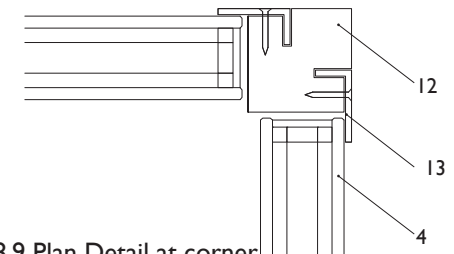


fig 2.8.9 Plan Detail at corner

- 1 - head mullion (shown for reference)
- 2 - aluminum cover plate
- 3 - fiberglass pressure plate
- 4 - quad-layer insulated glazing unit
- 5 - sill mullion (shown for reference)
- 6 - glazing block
- 7 - base support frame (shown for reference)
- 8 - wood shim
- 9 - vertical mullion (shown for reference)
- 10 - brakeform steel inserts (to receive mullion cap)
- 11 - rubber friction fit mullion cap
- 12 - milled nylon corner piece
- 13 - powder coated aluminum angle

STEP 9: ALUMINUM CLOSER PANELS

The powder coated aluminum closer panels installed in this step acts as a rainscreen and protect weather-proofing membranes below from physical and UV damage. They also conceal the connection between the roof panels and glazing system.

The closer panels are installed in two stages, the lower level, and the upper level. The lower panel must be installed first. Brackets attached to the visible portion of the panel hook over the upstand at the edge of the roof panels. These are mechanically fastened to the plywood blocking pre-installed on the edges of the roof panels. This bracket also holds a spring mechanism which is the key to the installation of the upper panel.

The upper panel also hooks over the roof upstand, and over the springs attached to the lower panel. When the upper panel is installed, the springs are compressed, which allows it to clip into place, holding it in position. In disassembly, this spring allows the upper panel to be easily removed without damaging or bending.

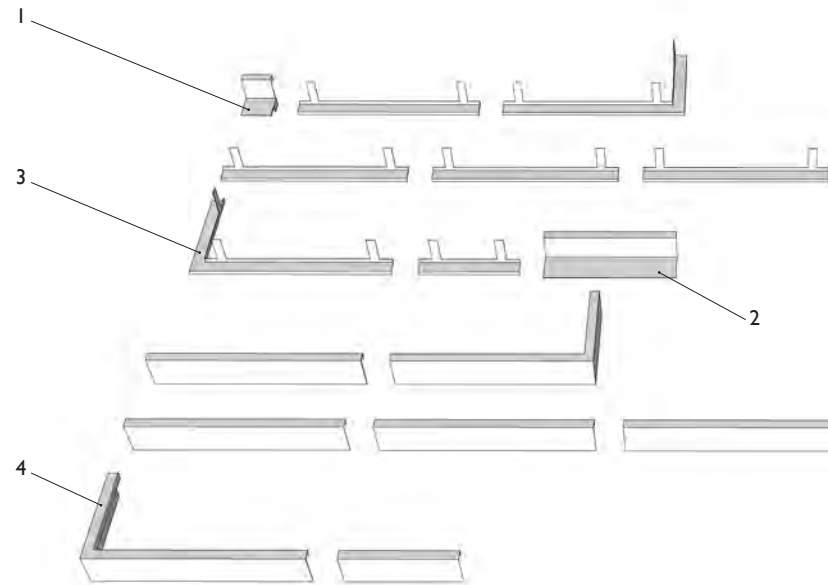


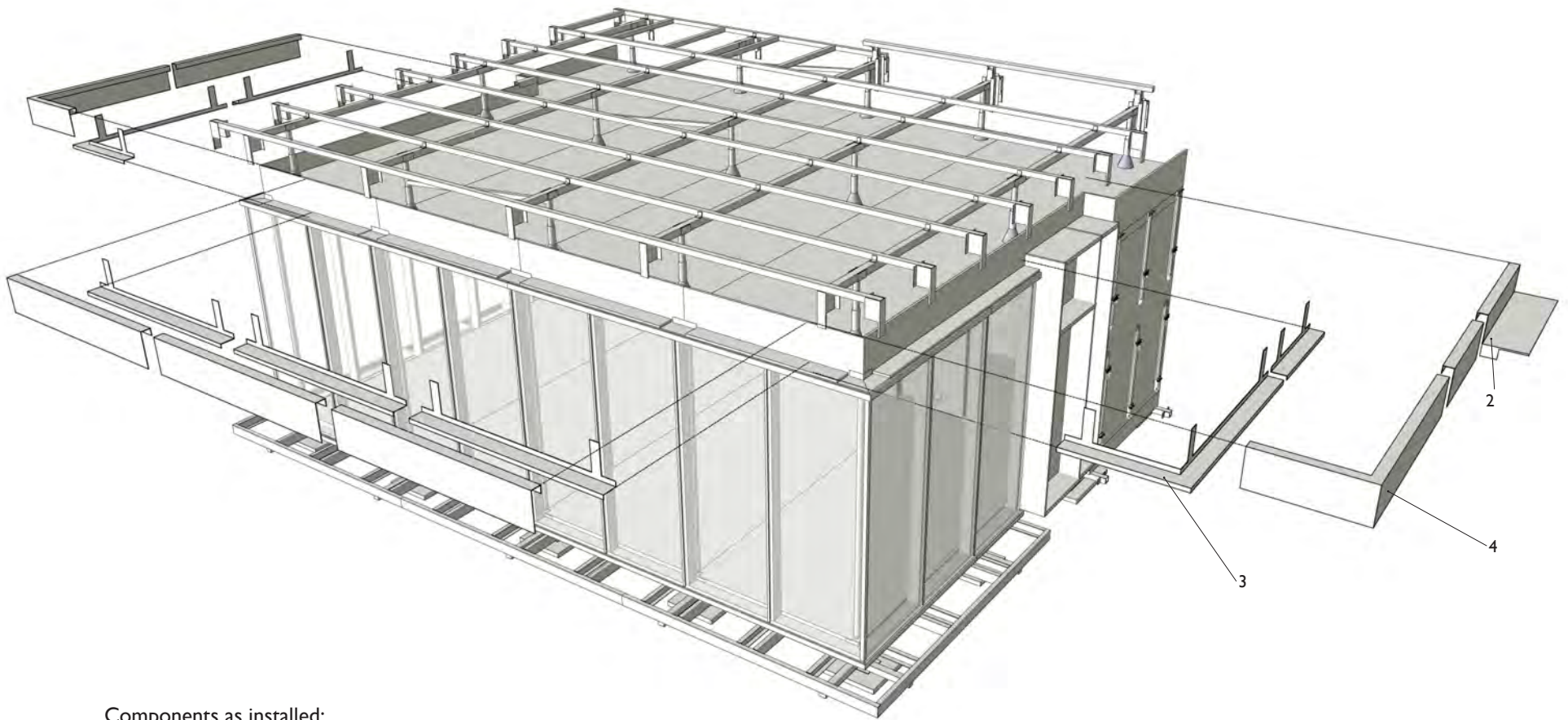
fig 2.9.2

fig 2.9.1 installing the corner panel



Components placed during this step:

- 1 - closer panel over insulated ventilation panel
- 2 - closer panel over door
- 3 - lower closer panel (7 pieces)
- 4 - upper closer panel (7 pieces)



Components as installed:

- 2 - closer panel over door
- 3 - lower closer panel
- 4 - upper closer panel

fig 2.9.3

Parts of Aluminum Closer Panel

- 1 - spring
- 2 - 6" bolt
- 3 - bracket
- 4 - upstand bracket (hooks lower panel to roof parapet)
- 5 - upper closer panel (hooks over parapet)
- 6 - exposed portion of lower panel

fig 2.9.4 close-up of lower closer panel

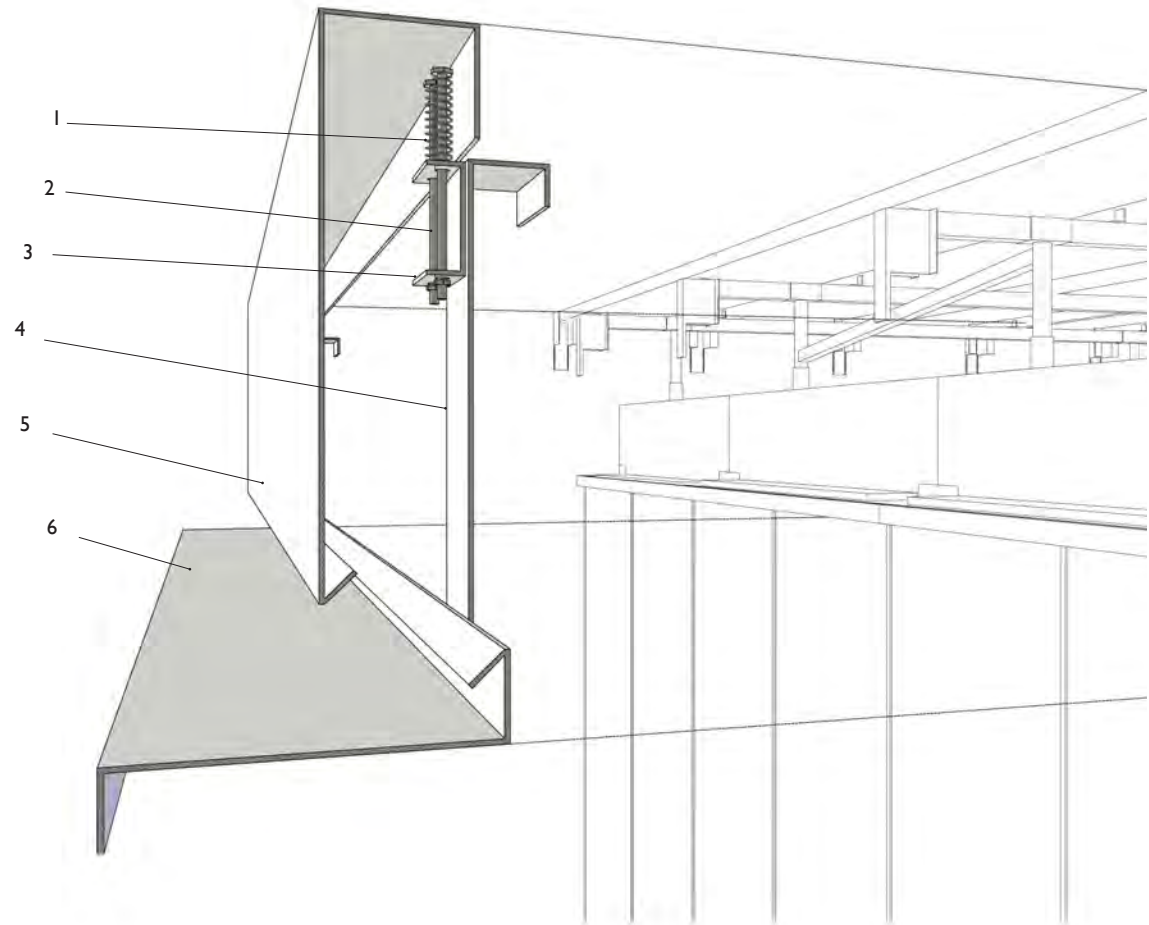
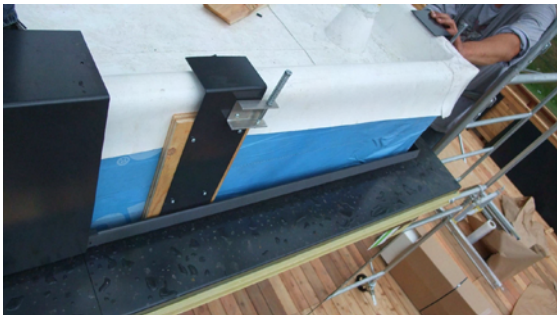


fig 2.9.5

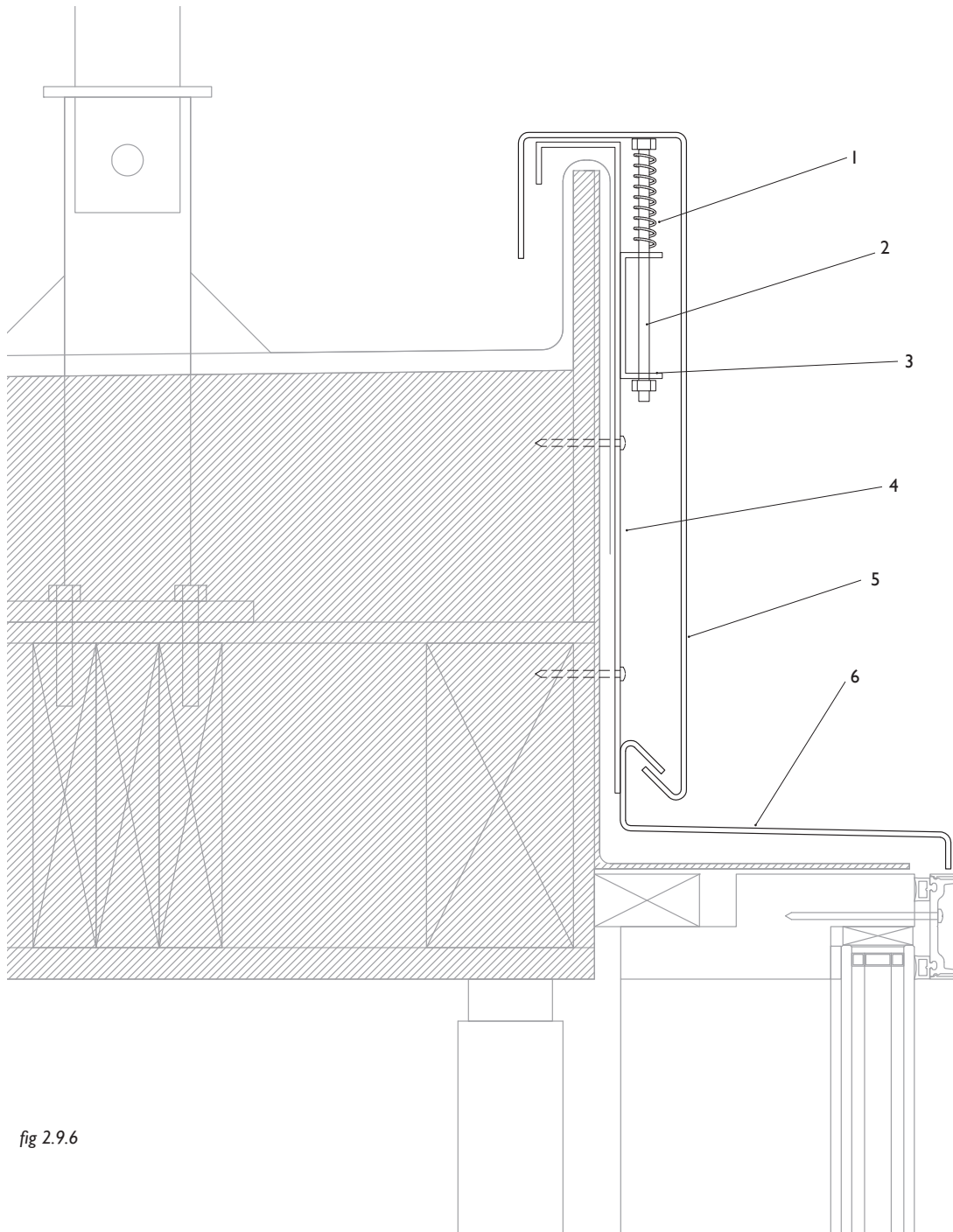


fig 2.9.6

- 1 - spring
- 2 - 6" bolt
- 3 - bracket
- 4 - upstand bracket (hooks lower panel to roof parapet)
- 5 - upper panel (hooks over parapet)
- 6 - exposed portion of lower panel

STEP 10: EXTERIOR BLIND SUPPORTS

The blind supports ensure that the exterior blinds are correctly positioned relative to the glazing system and the BIPV fascia (at this point not yet installed). They span between the custom end brackets found on the purlins and HSS frames, and are bolted to these brackets. Special brackets provided by Nysan Solar Control, the exterior blinds manufacturer, are preinstalled to the blind supports, and will hold the motor heads of the exterior blinds ensuring that they are positioned correctly.

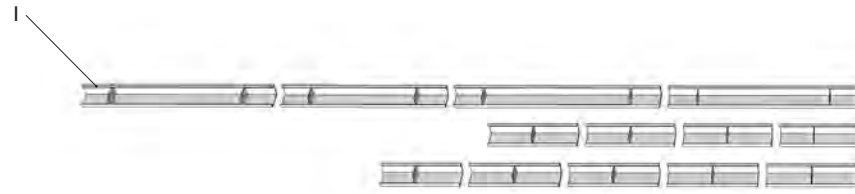


fig 2.10.2

fig 2.10.1 installing the blind supports



Components placed during this step:
1 - 13 blind supports

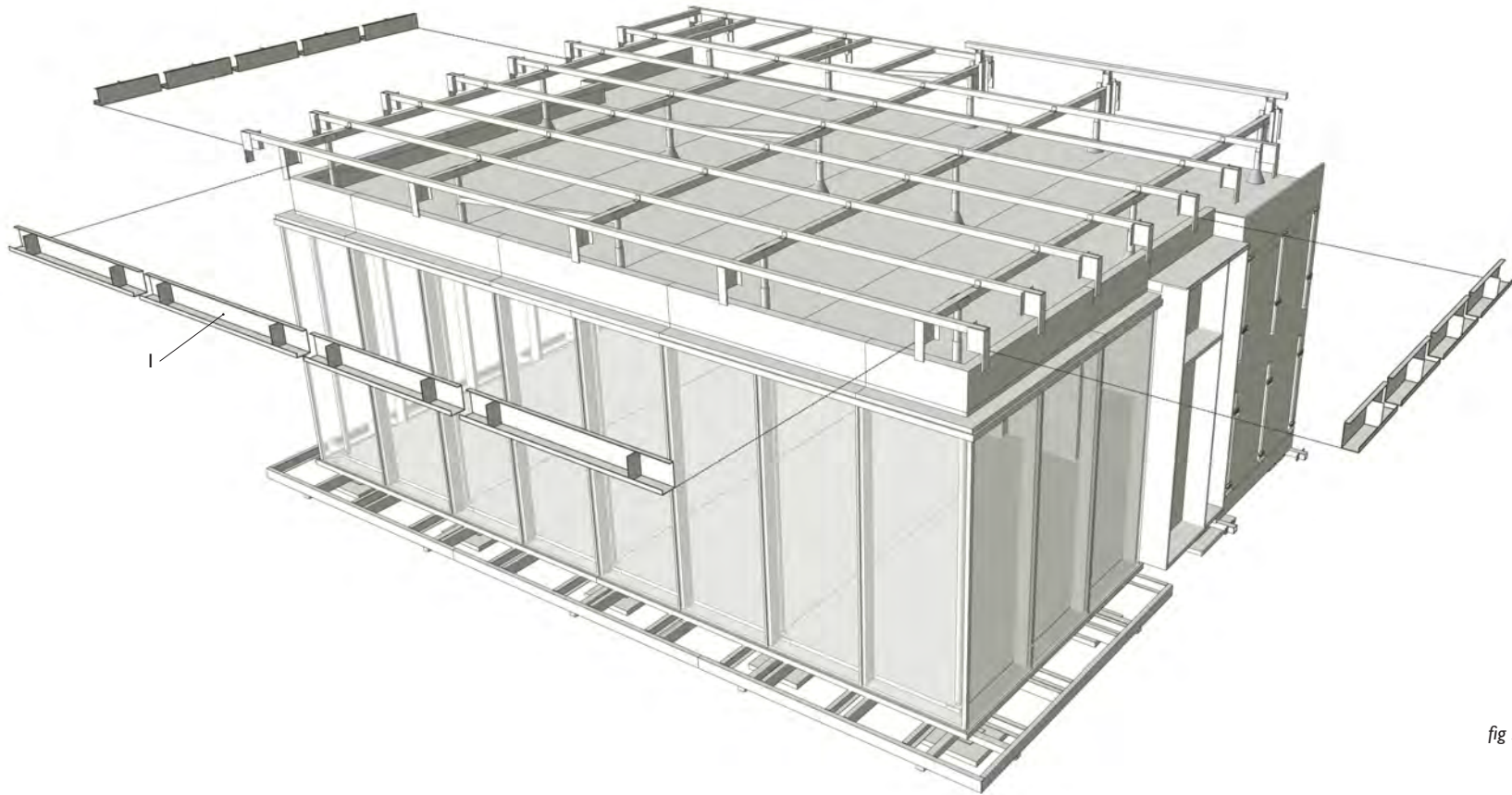


fig 2.10.3

Components as installed:
I - blind support

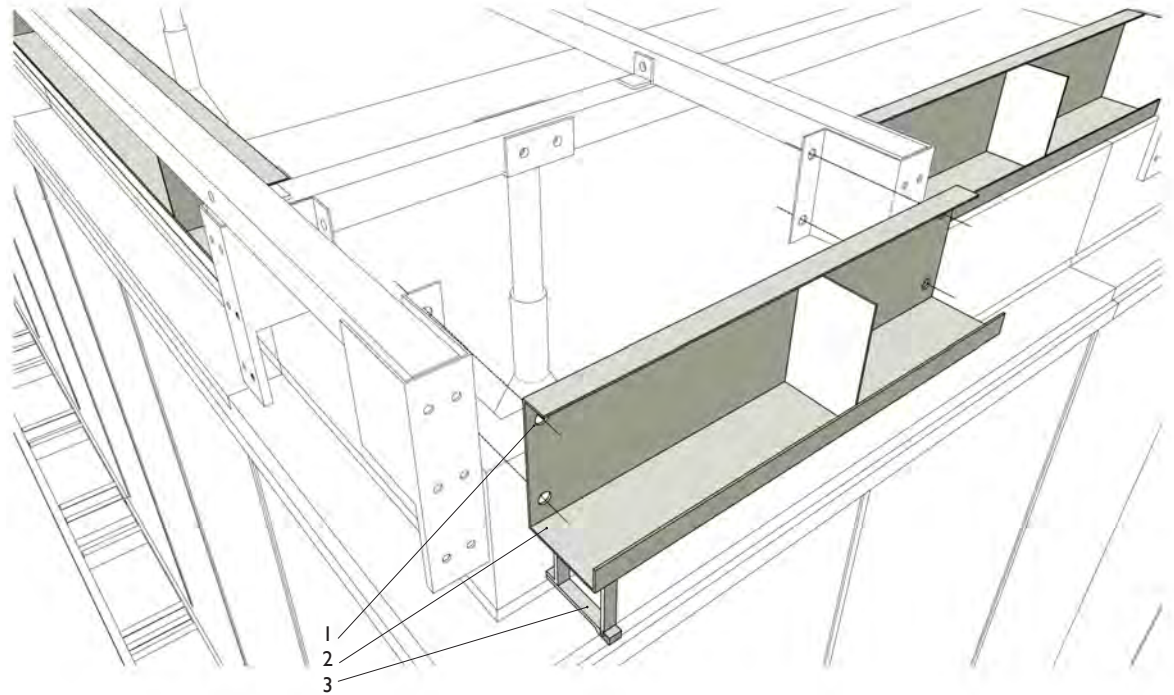


fig 2.10.4

Parts of Blind Supports

- 1 - bolted connection to roof racking frame end brackets
(similar condition at purlin end brackets)
- 2 - brakeform steel support
- 3 - blind bracket

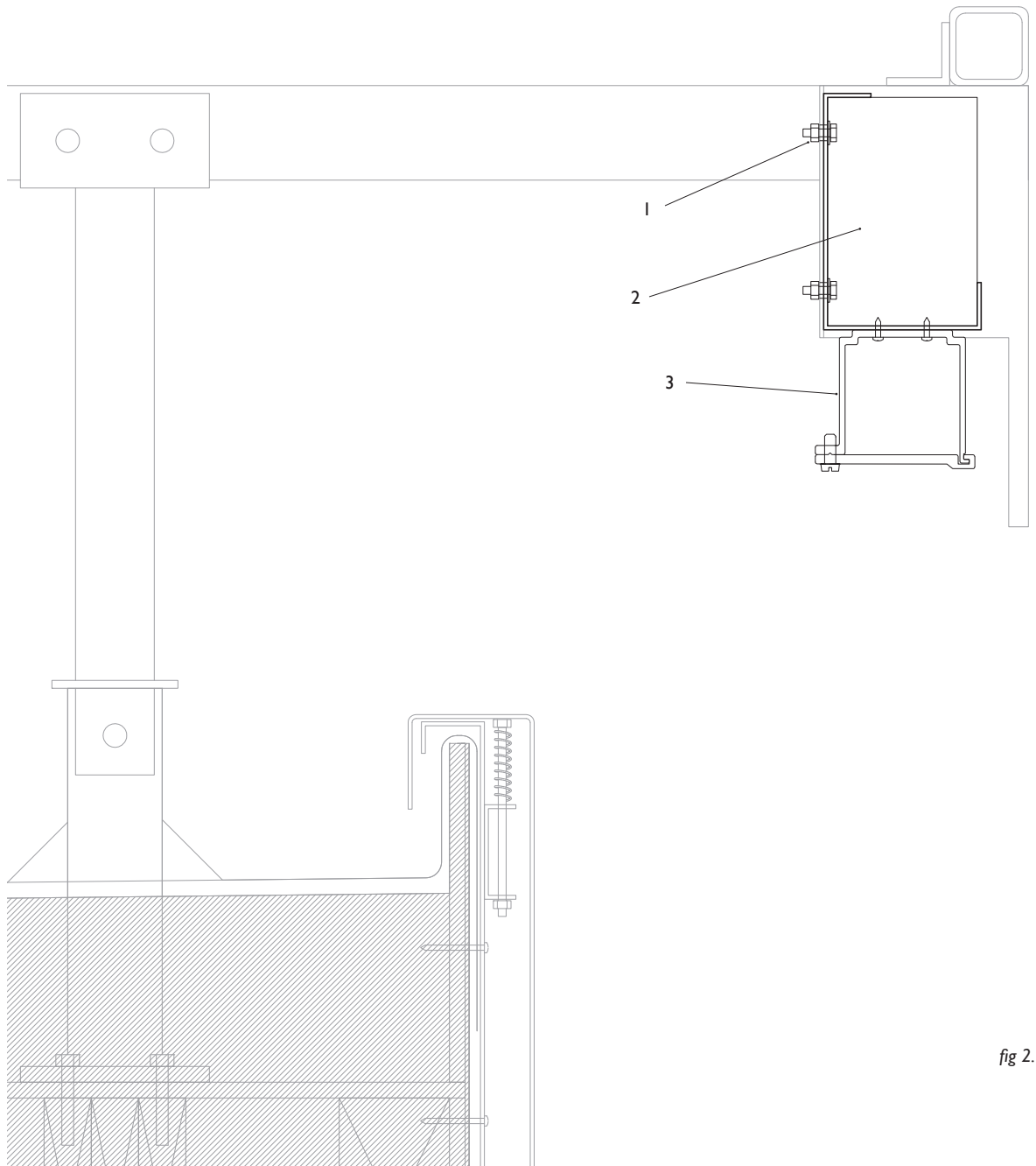


fig 2.10.5

- 1 - bolted connection to roof racking frame end brackets
(similar condition at purlin end brackets)
- 2 - brakeform steel support
- 3 - blind bracket

STEP 11: FASCIA CLADDING SUPPORTS

Like the blind supports, the fascia cladding supports also bolt to the end brackets of HSS frames and purlins. Vertical rails and brackets which will hold the BIPV cladding panels are pre-installed on these supports.

These rails and brackets are part of an aluminum cladding support system called QuadroClad manufactured by Hunter Douglas, and fit together with horizontal rails that are adhered to the back of the BIPV cladding panels.

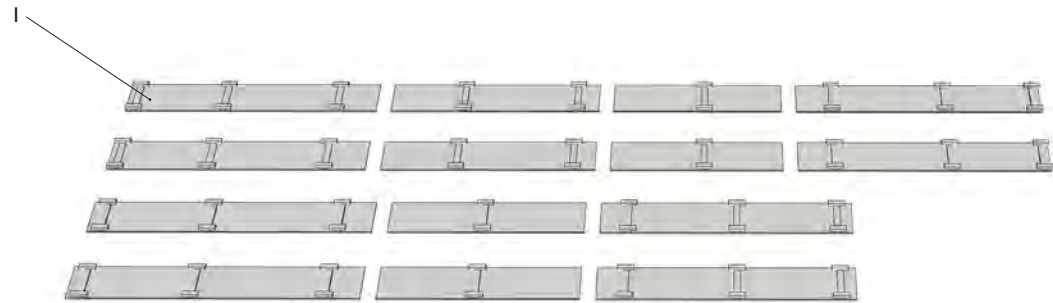
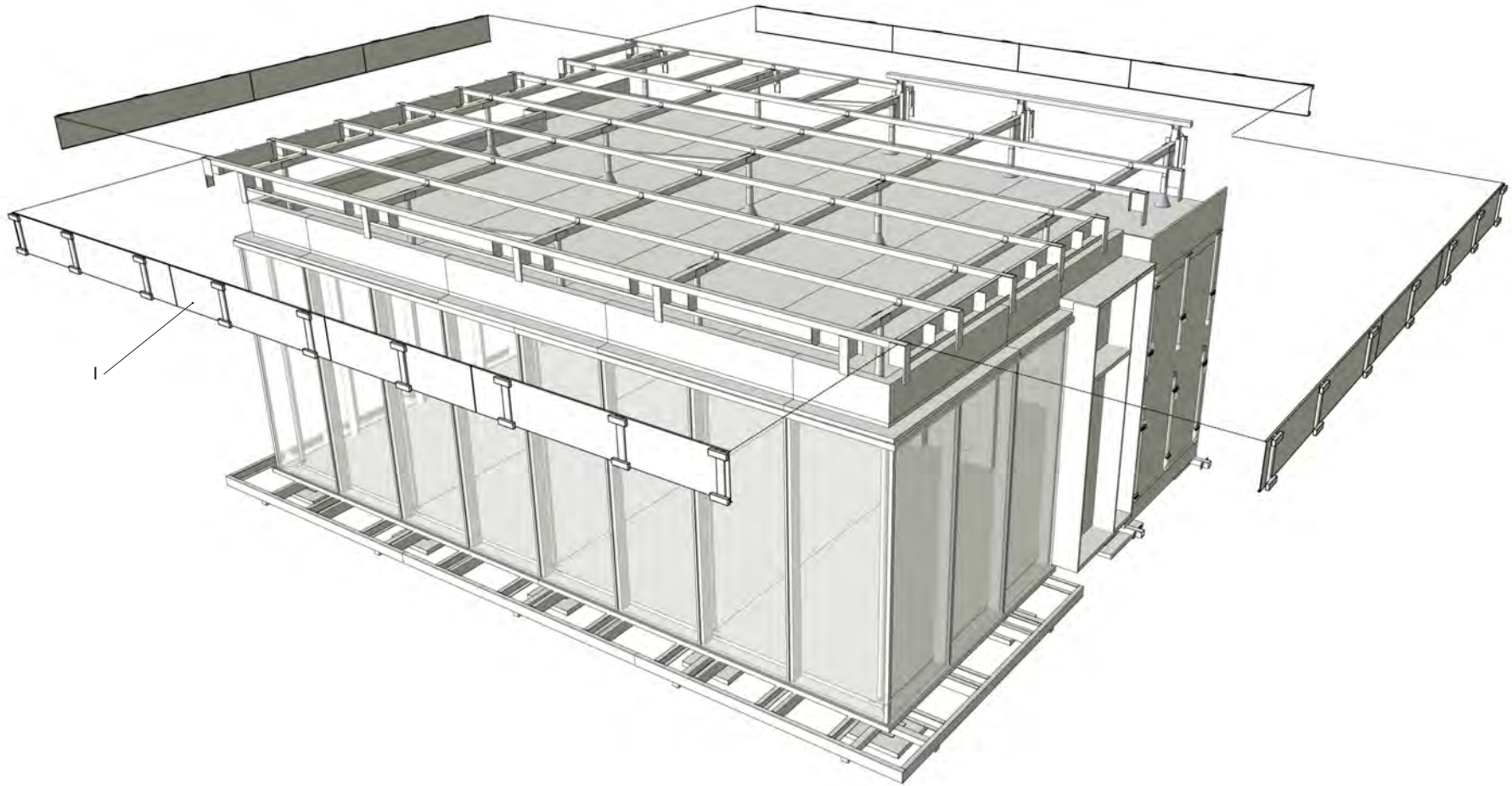


fig 2.11.2

fig 2.11.1 cladding supports as installed

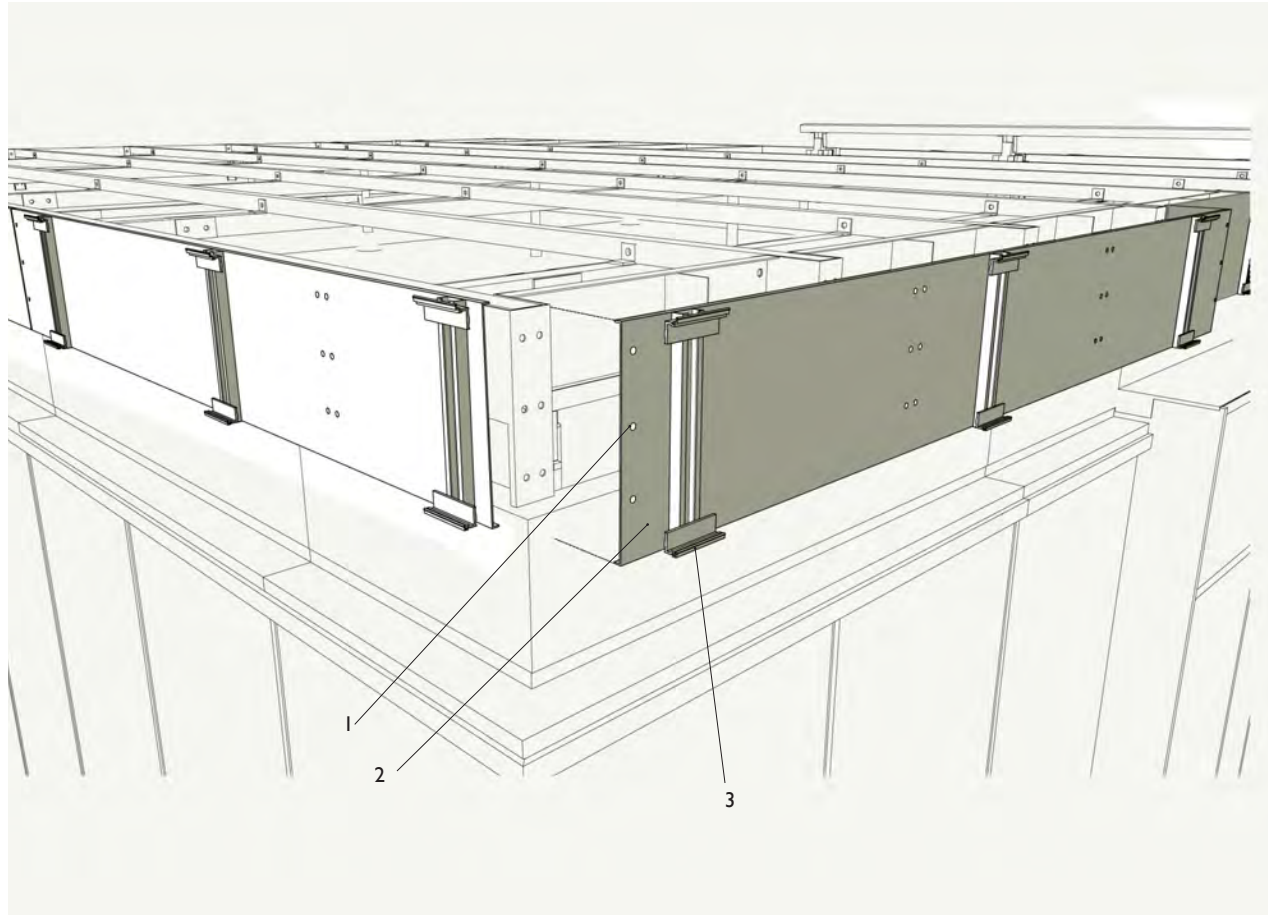


Components placed during this step:
1 - 14 fascia support panels



Components as installed:
I - fascia support panel

fig 2.11.3



Parts of Cladding Supports

- 1 - bolted connection to roof racking frame end brackets
(similar condition at purlin end brackets)
- 2 - brakeform steel panel
- 3 - aluminum cladding rail and bracket system

fig 2.11.4

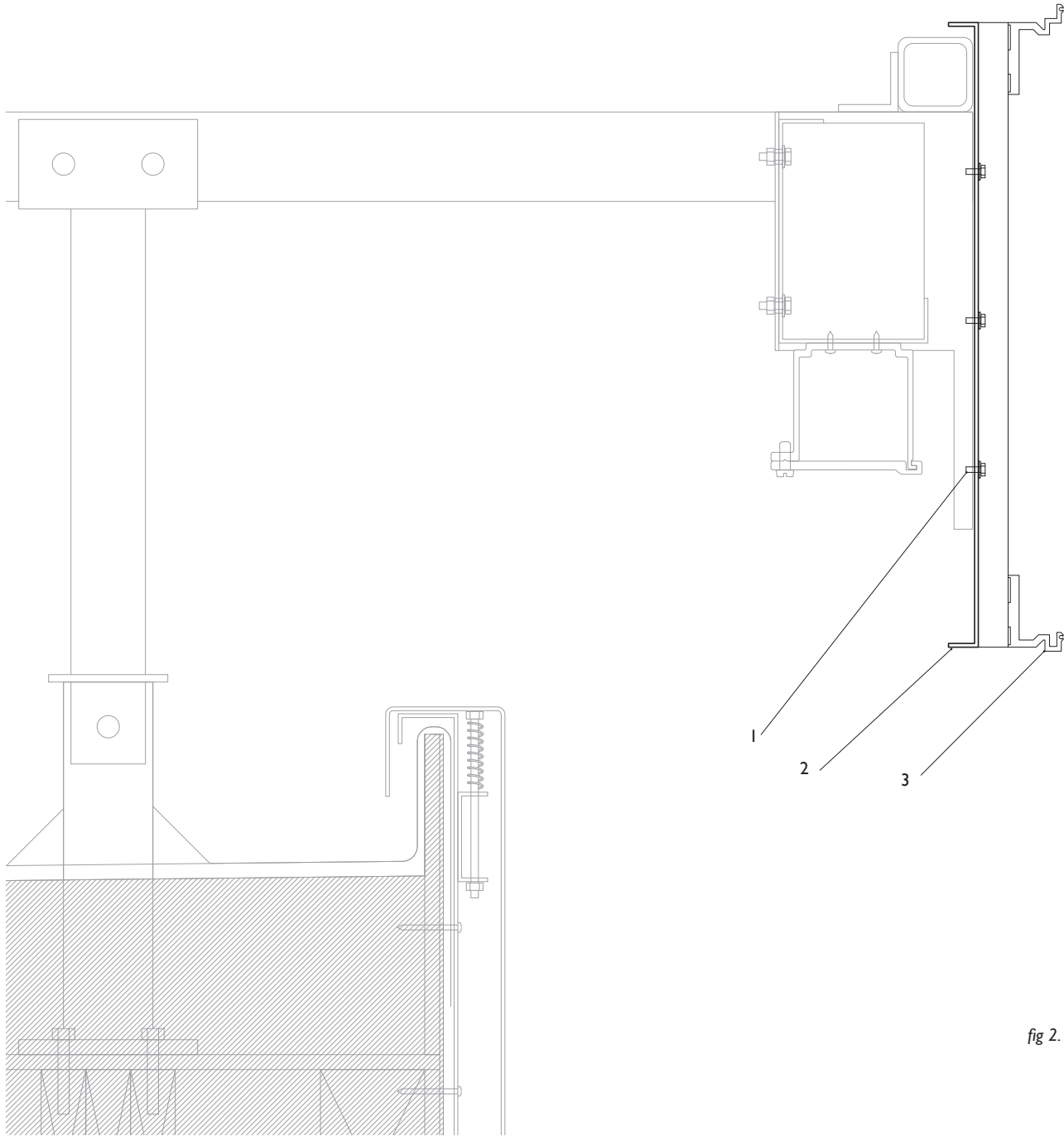


fig 2.11.5

- 1 - bolted connection to roof racking frame end brackets
(similar condition at purlin end brackets)
- 2 - brakeform steel panel
- 3 - aluminum cladding rail bracket system

STEP 12: EXTERIOR BLINDS

The automated exterior Venetian blinds are manufactured by Nysan Solar Control and consist of a motor head (with two motors for the top and bottom zones of the blind which can be operated separately), the aluminum slats that make up the blind and the lifting tapes which control them, and the tension cables. The brackets for the blinds have already been installed (Step 10), and pre-attached to the blind supports. This makes installation of the blinds very straightforward. They are simply hung from the brackets.

Once the blinds are in place, the tension cables can be installed. These pass through a cedar grate at the building's perimeter, which must also be installed at this time. The cables are secured through brackets in the base support frame, and should be tightened sufficiently to prevent the blinds from moving enough to hit the building in high winds.

For disassembly, blinds should be removed while in the fully retracted position. The tension cables can be released from below, and brackets opened to release the blind motor head.

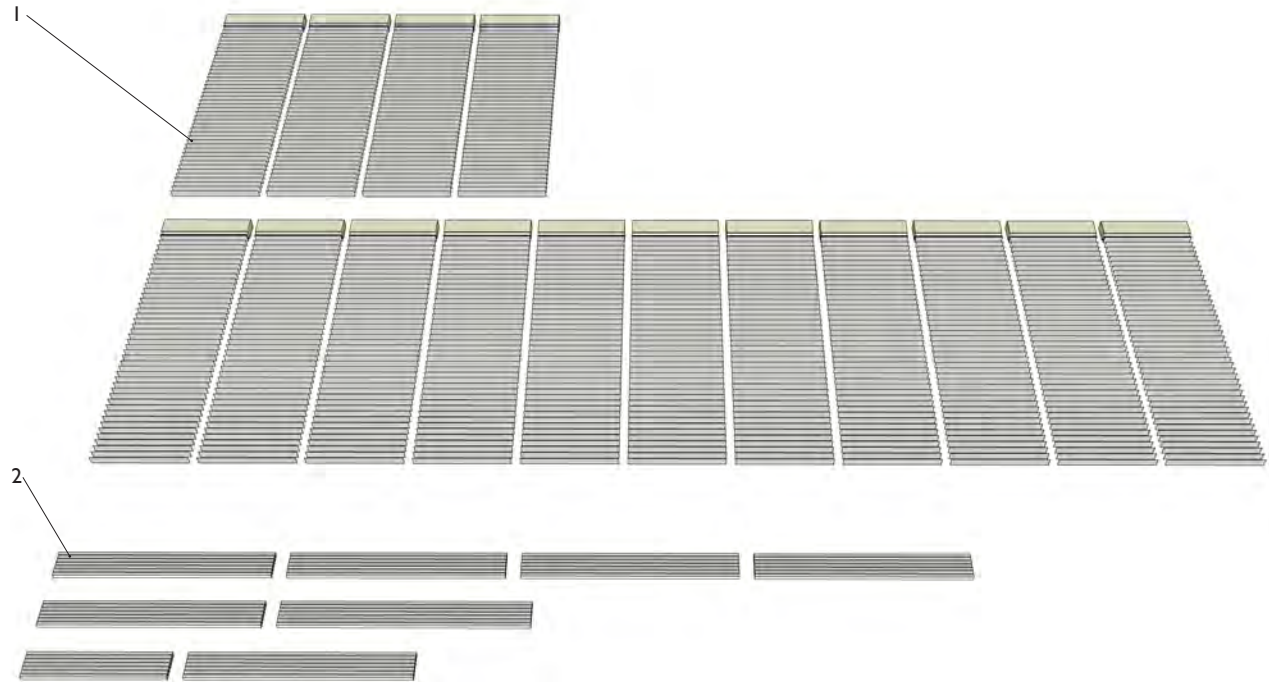


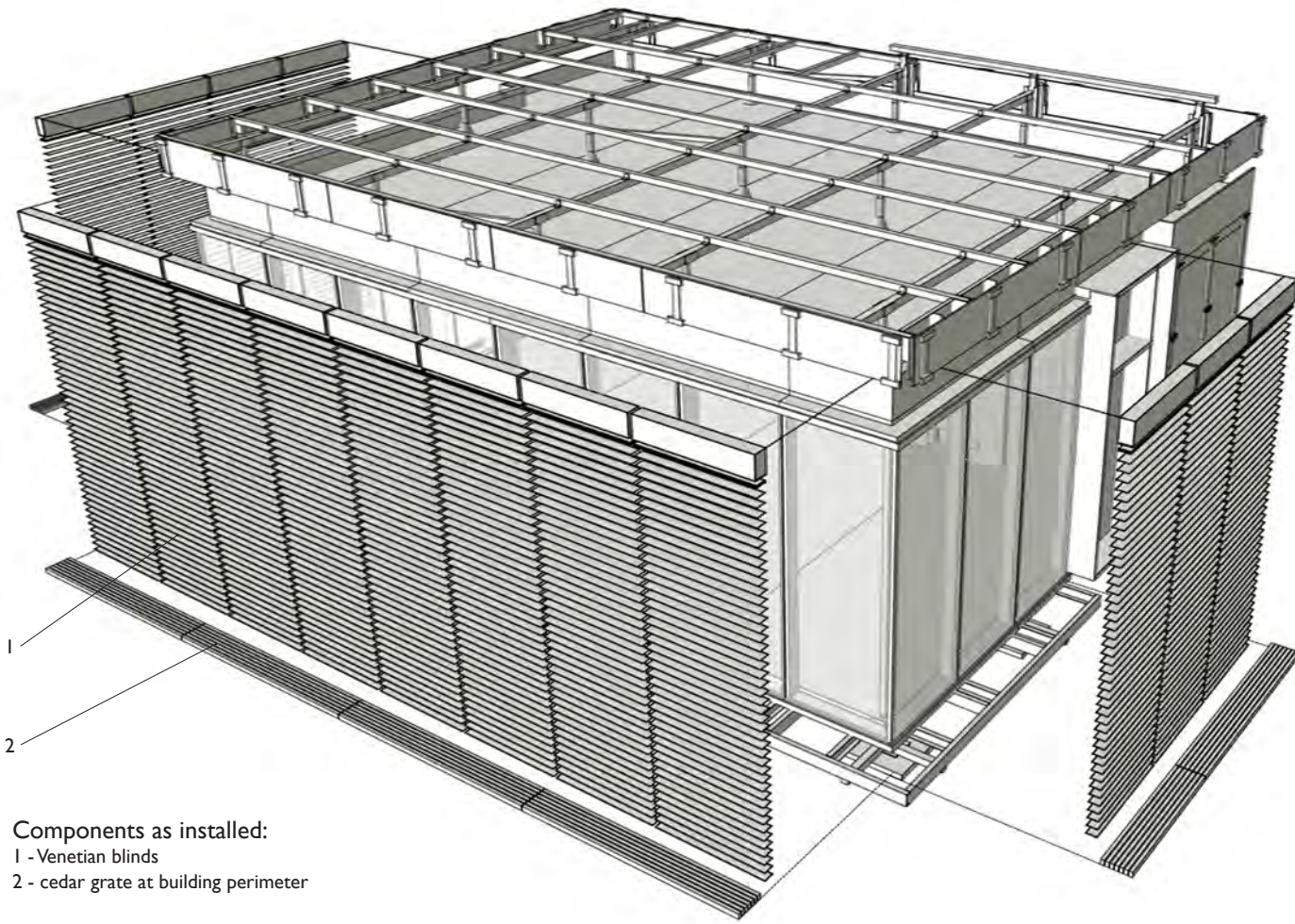
fig 2.12.2

fig 2.12.1 installing the blinds



Components placed during this step:

- 1 - exterior Venetian blinds (15 pieces)
- 2 - cedar grate at building perimeter (8 pieces)



Components as installed:
1 - Venetian blinds
2 - cedar grate at building perimeter

fig 2.12.3

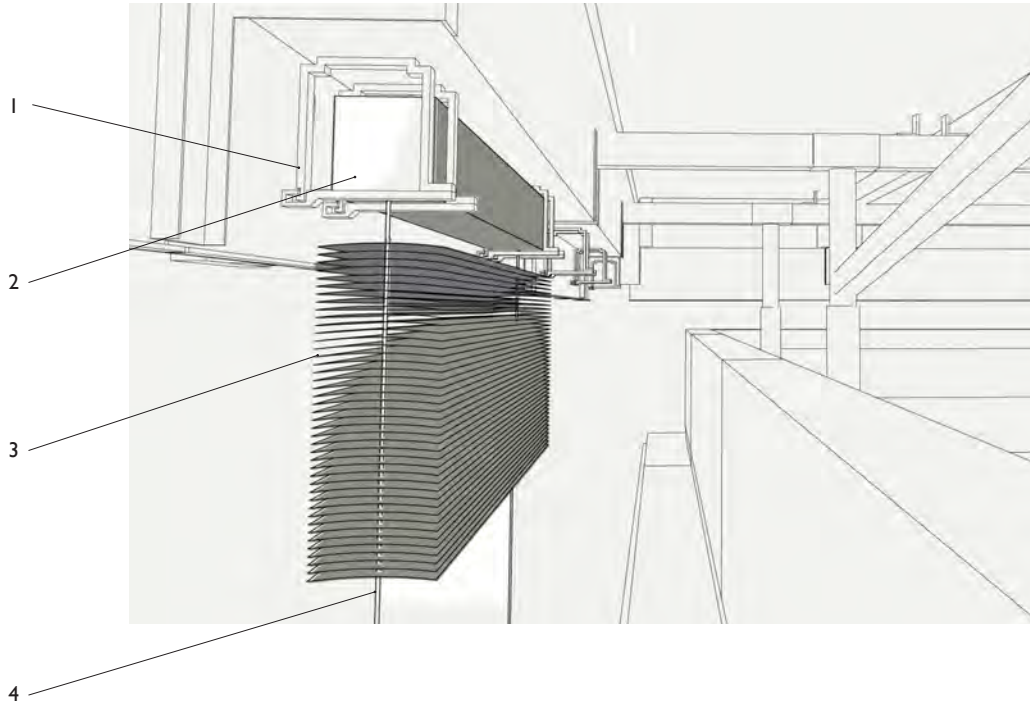


fig 2.12.5

- 1 - blind bracket pre-mounted to blind supports
- 2 - blind motor head
- 3 - aluminum slats in retracted position
- 4 - tension cable
- 5 - cedar grate

fig 2.12.4 installing the tension cables

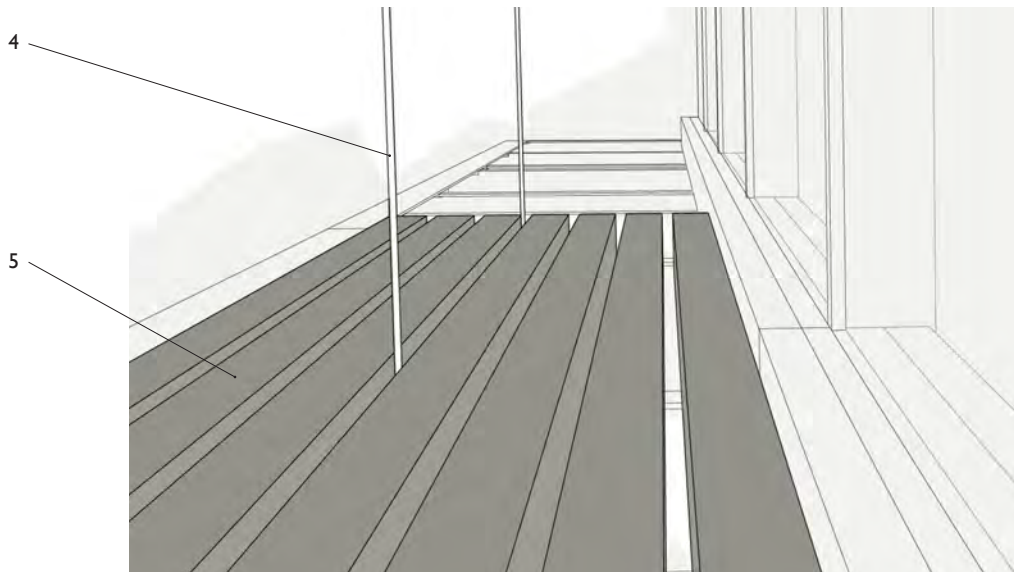


fig 2.12.6

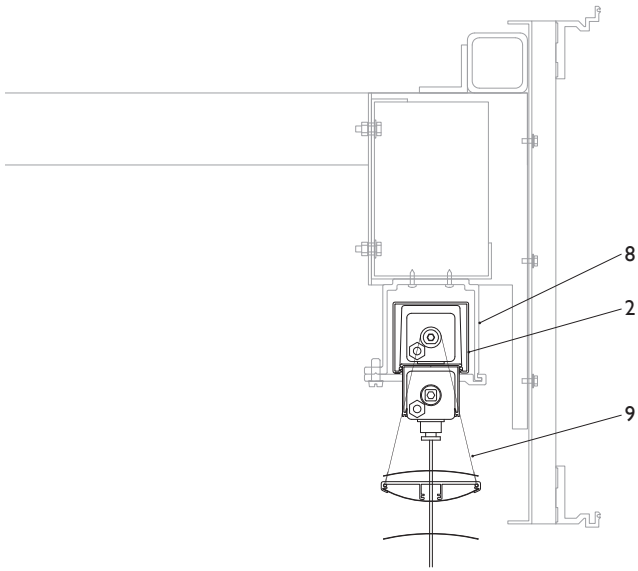


fig 2.12.7 Section Detail 12-A

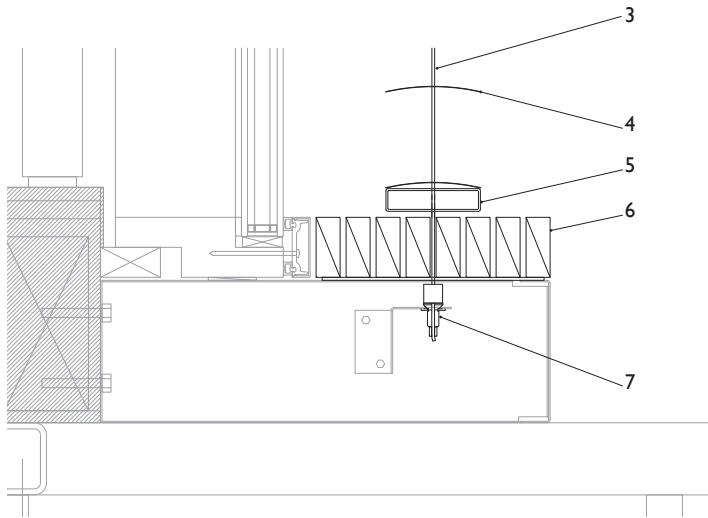


fig 2.12.8 Section Detail 12-B

- 1 - blind bracket pre-mounted to blind supports
- 2 - blind motor head
- 3 - tension cable
- 4 - aluminum slat (spaced every 4")
- 5 - bottom rail
- 6 - cedar grate
- 7 - tension cable fixed into pre-installed bracket
- 8 - blind bracket pre-mounted to blind supports
- 9 - lifting tape

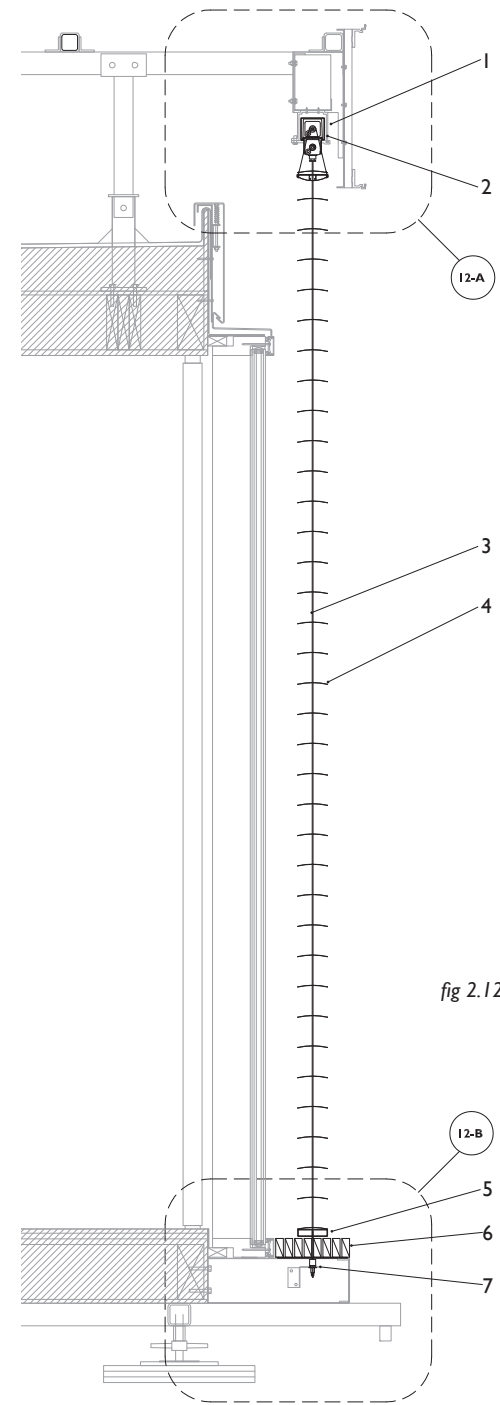


fig 2.12.9

STEP 13: BIPV CLADDING PANELS

The Building-Integrated Photovoltaic (BIPV) cladding panels manufactured by Schüco Inc. contain back-side contact, monocrystalline photovoltaic cells of the highest efficiency commercially available at the time of the competition. They are encapsulated between two layers of glass. These panels provide the cladding on the east, west and south facades. They will generate energy from low-angled sun in winter, and in the early morning and late afternoon throughout the year.

Two horizontal rails, which are part of the Hunter Douglas QuadroClad system, are adhered to the back of each panel well in advance of assembly. These lock into the brackets installed on the vertical rails pre-adhered to the fascia cladding supports (Step 2) and provide a frameless mounting system for the panels.

On the east and west elevations where there are multiple rows of cladding panels, the vertical rails and brackets are pre-installed to the walls of the densepack, and receive the BIPV panels in the same fashion.

A special hoist was designed to aid the installation of these panels as they are very heavy and very delicate. This hoist sat atop a lift of scaffolding and contained a pulley which was used to hoist and stabilize the panels during installation. The same hoist is used to remove the panels during disassembly.

fig 2.13.1 hoist mounted atop scaffolding

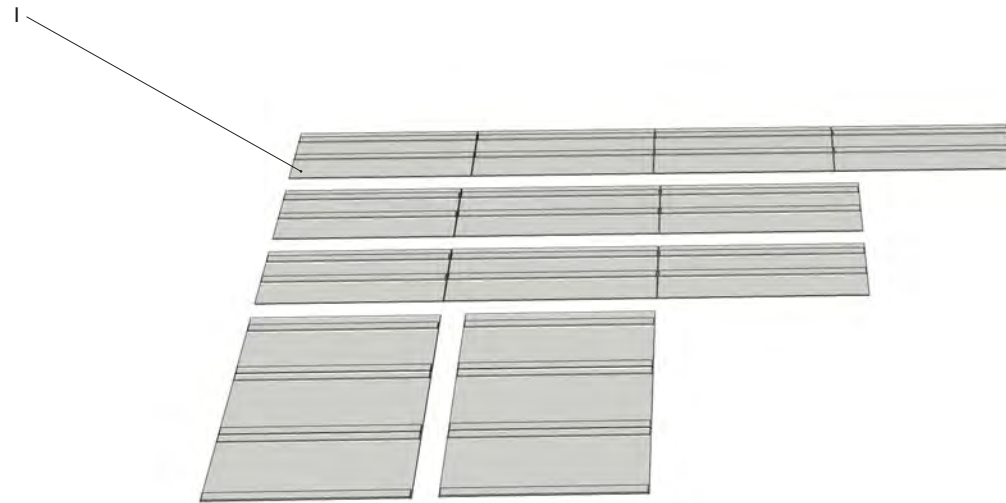
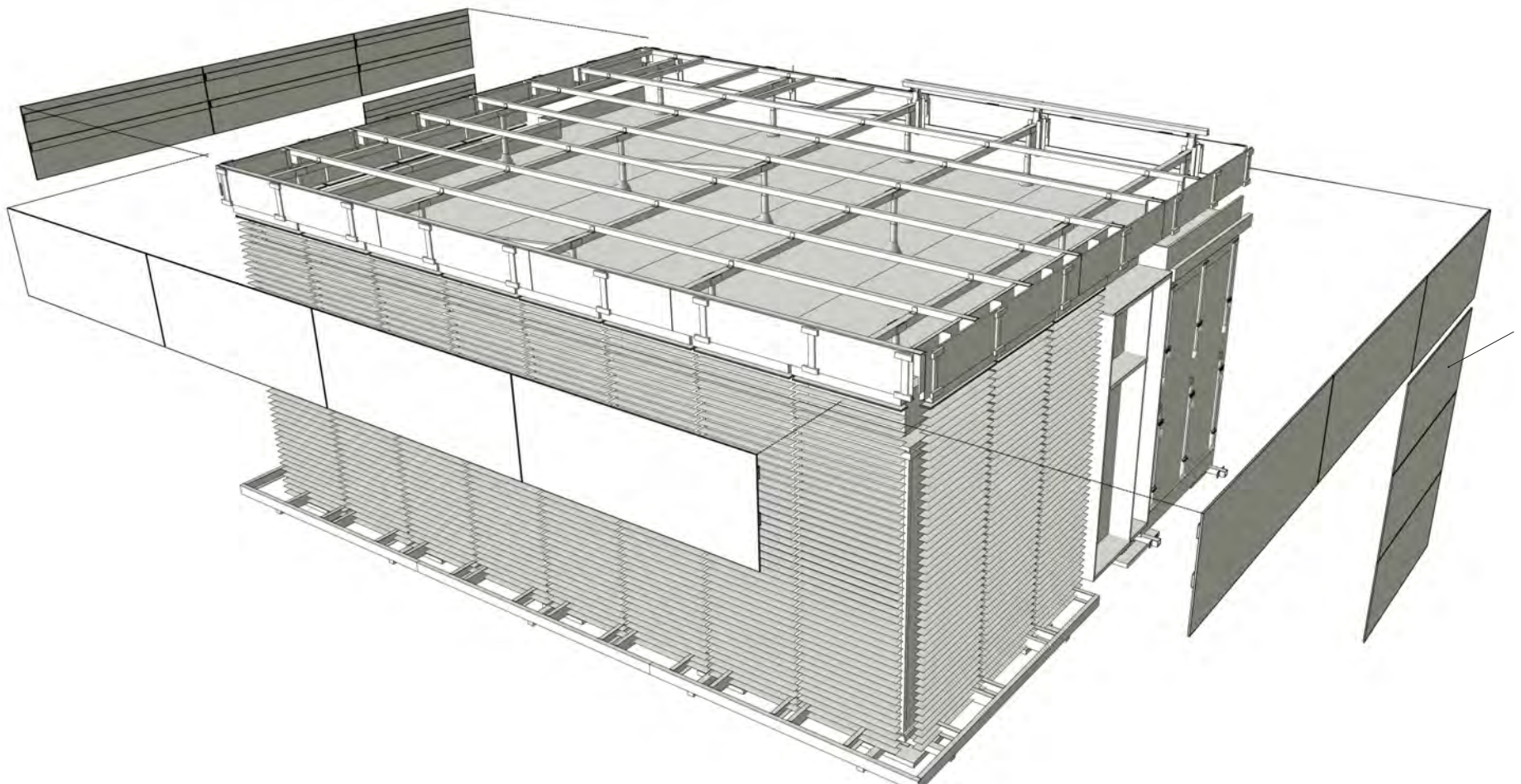


fig 2.13.2

Components placed during this step:

1 - 16 BIPV cladding panels



Components as installed:
1 - BIPV cladding panel

fig 2.13.3

Parts of BIPV Cladding Panels

- 1 - glass encapsulated photovoltaic cells
- 2 - horizontal aluminum rail
- 3 - rails and bracket system aluminum cladding
(installed in step 11)

fig 2.13.4 installing the BIPV cladding panels

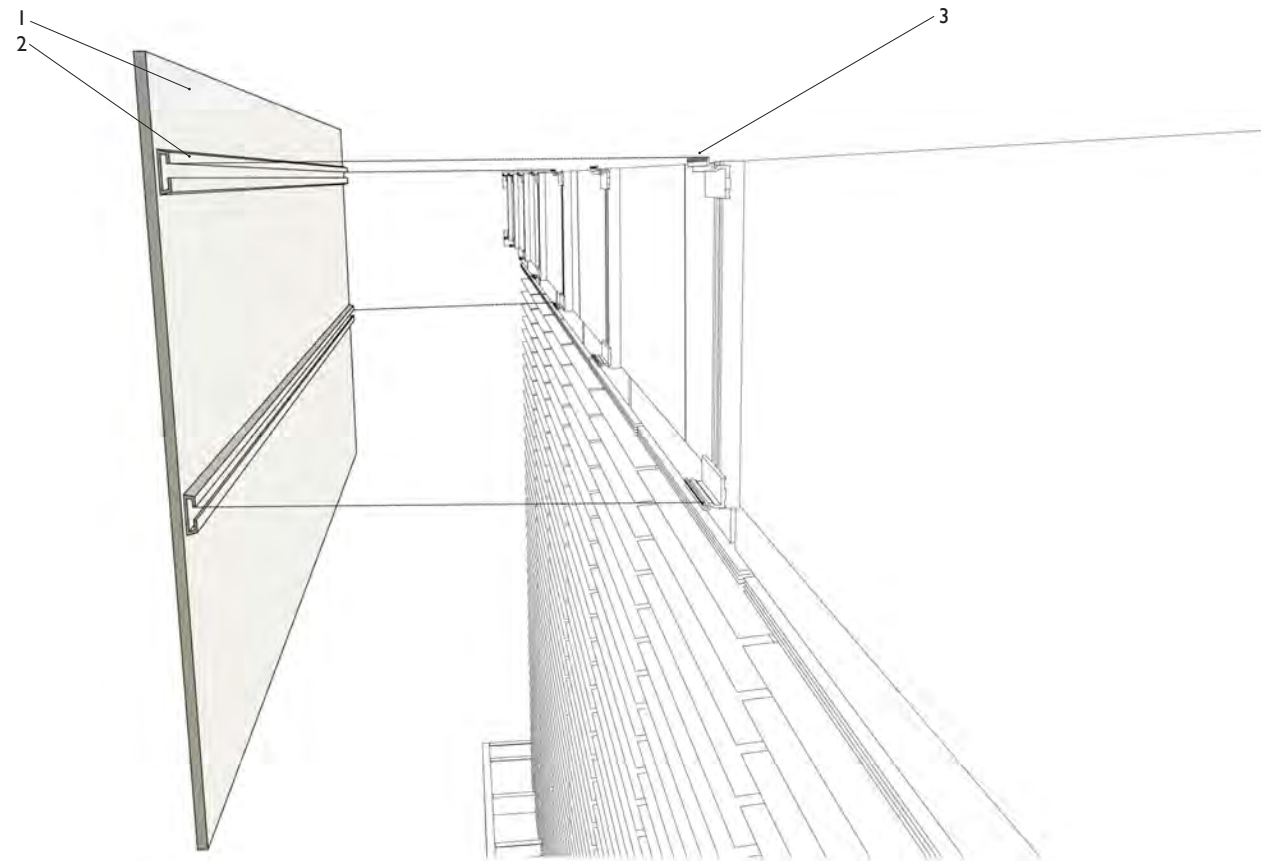


fig 2.13.5

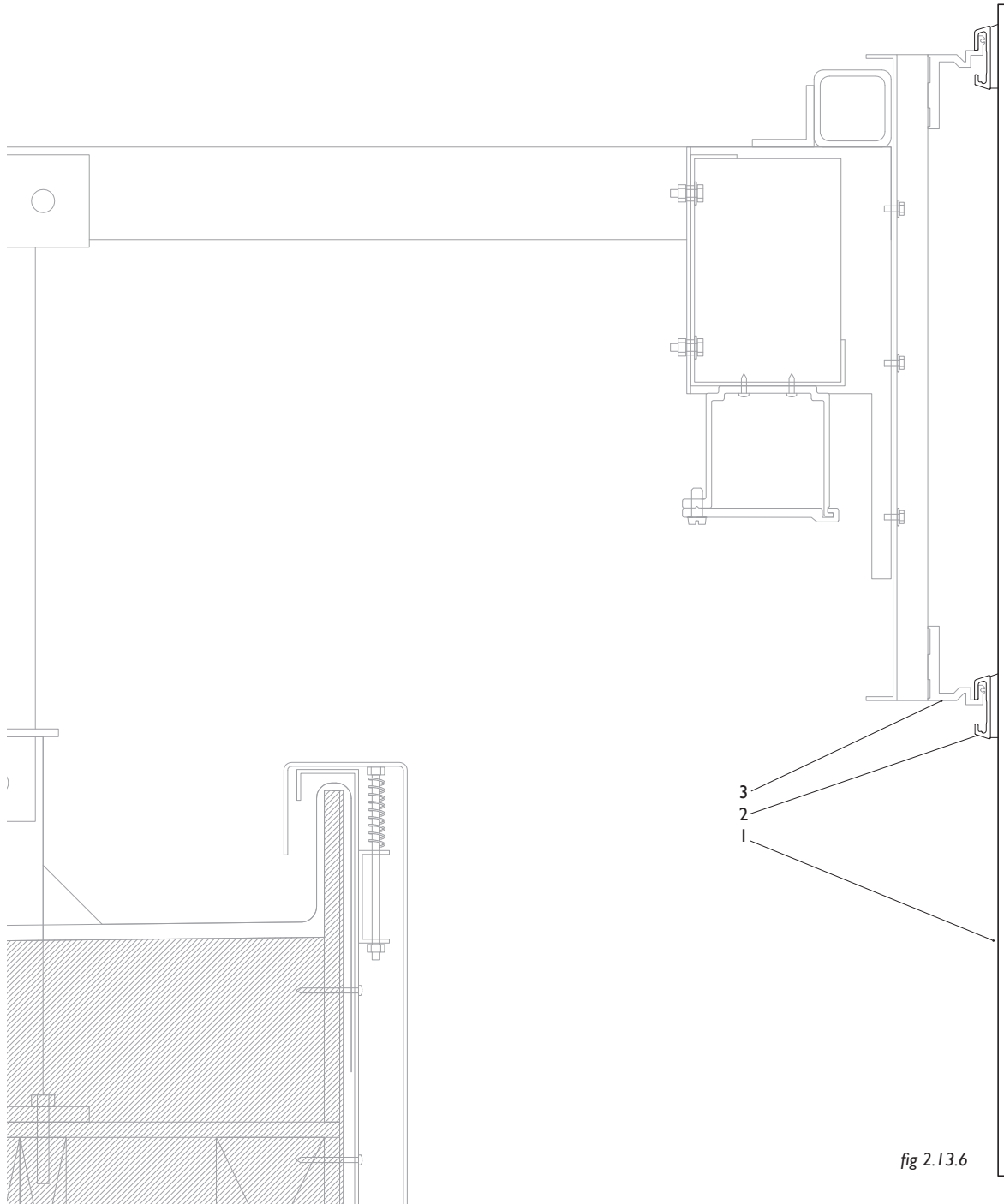
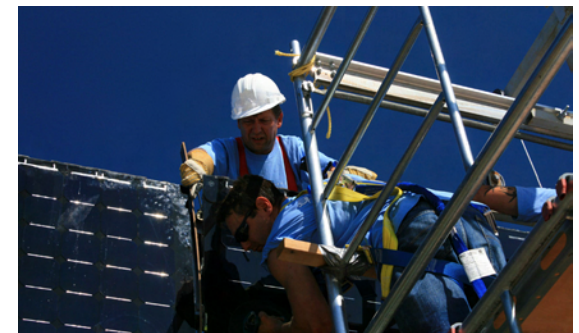


fig 2.13.6

- 1 - glass encapsulated photovoltaic cells
- 2 - horizontal aluminum rail
- 3 - rails and bracket system aluminum cladding
(installed in step 11)

fig 2.13.7
installing a BIPV cladding panel using suction cups and hoist



STEP 14: SOLAR PANELS & SOLAR THERMAL COLLECTORS

The roof-top solar array of the North House is composed of 46 monocrystalline photovoltaic panels manufactured by Day 4 Energy. The panels are mounted roughly two-and-a-half feet above the insulated roof surface, allowing adequate space to service or remove individual panels from below and also to provide ample space for air circulation around the panels thus preventing overheating that can lead to decreased efficiency.

Four custom designed brackets are pre-installed to the underside of each panel. These minimize the gaps between panels to allow for the maximum roof area to be covered with active solar cells.

All solar panels are numbered and should be installed according to this specific configuration and sequence. Because of the way the brackets must be slid into place, it is easiest to install an east-west row of panels before moving to the next row. As connections are made from the underside of the panels it is easiest to begin at the south and work towards the north where there is more convenient roof access.

Once a panel is in place, the brackets are bolted to the purlins below. Bolts can be freely accessed from the space below the panels.

The solar thermal collectors are bolted to an angled rack during this stage and necessary plumbing connections also made. Two panels, on which the heat dissipaters and inverters have already been mounted are also installed at this time.

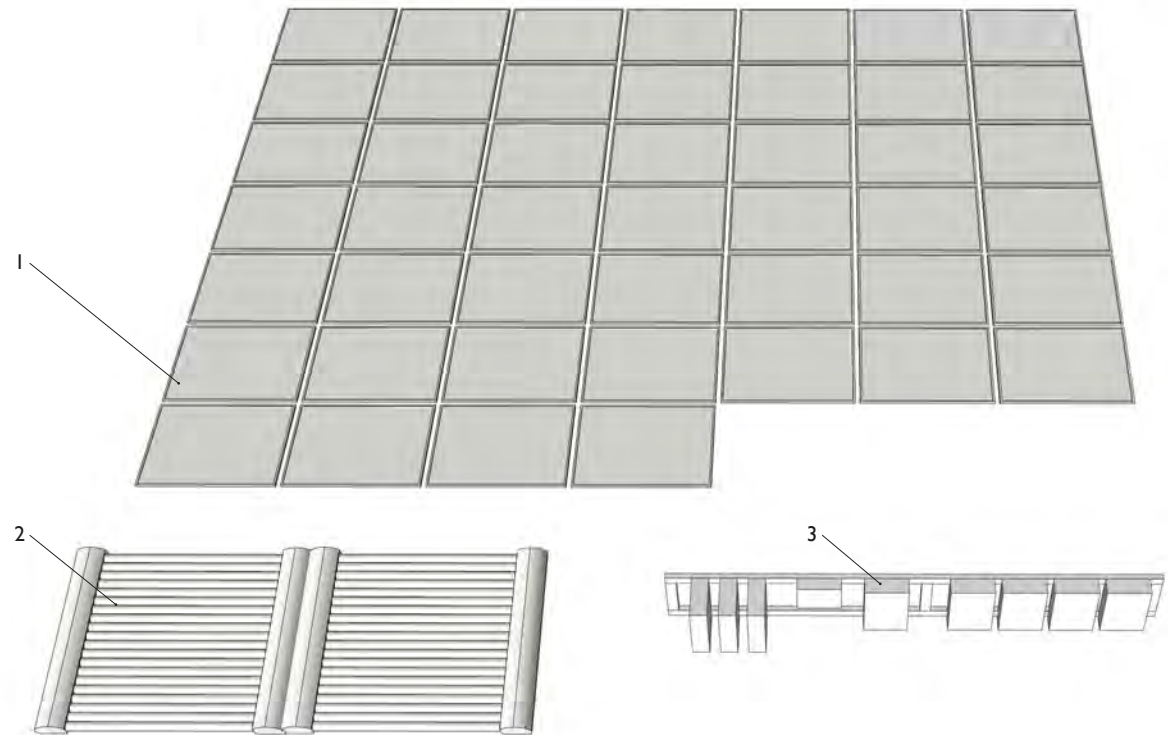
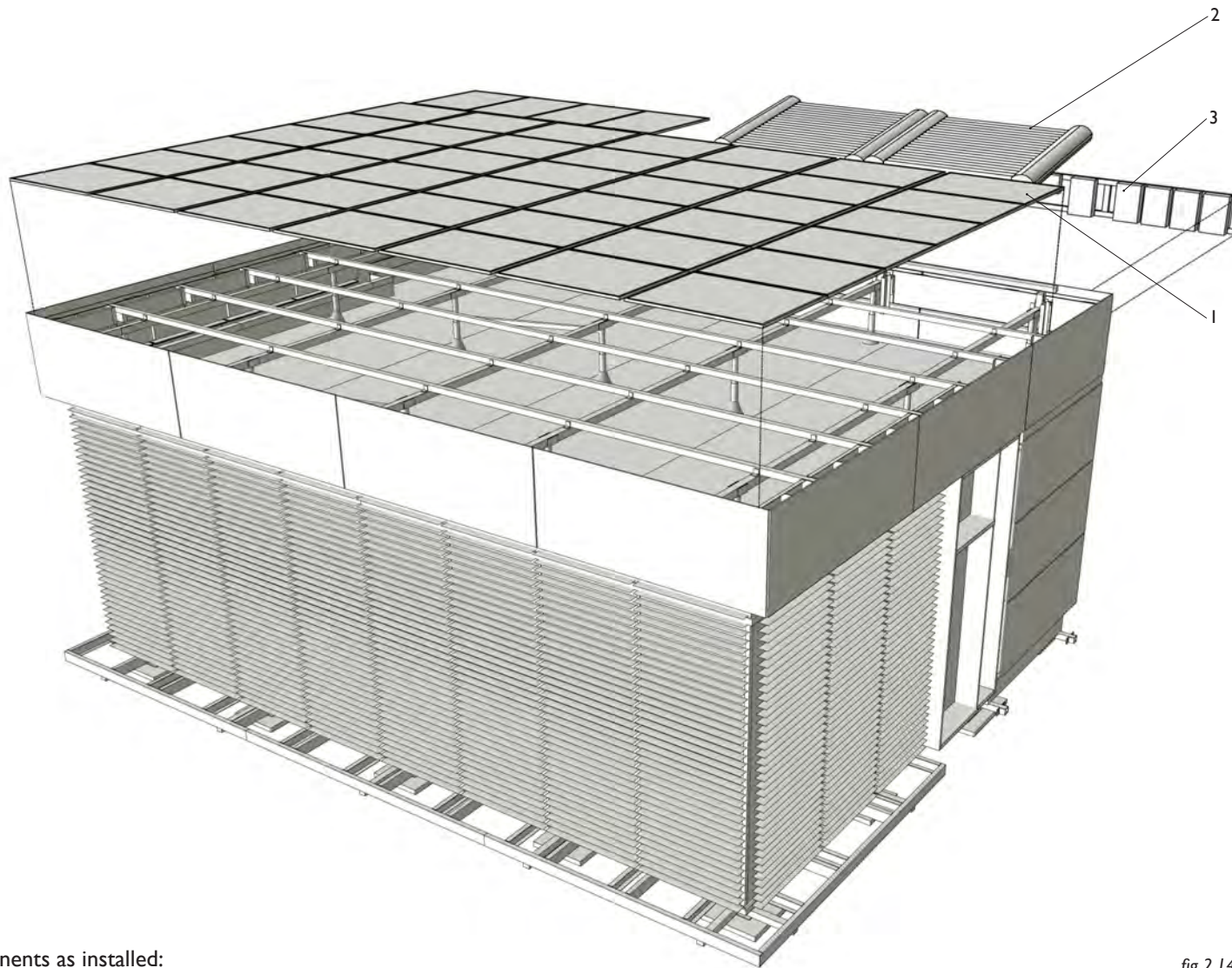


fig 2.14.1

Components placed during this step:

- 1 - 46 solar panels with pre attached brackets
- 2 - 2 solar thermal collectors
- 3 - 2 panels with pre-mounted inverters and heat dissipaters



Components as installed:

- 1 - solar panels with pre attached brackets
- 2 - solar thermal collectors
- 3 - panels with pre-mounted inverters and heat dissipaters

fig 2.14.2

Components installed during this step:

- 1 - brakeform aluminum bracket pre-attached to solar panel
- 2 - solar panel with aluminum frame
- 3 - solar thermal collectors as installed
- 4 - solar panels as installed

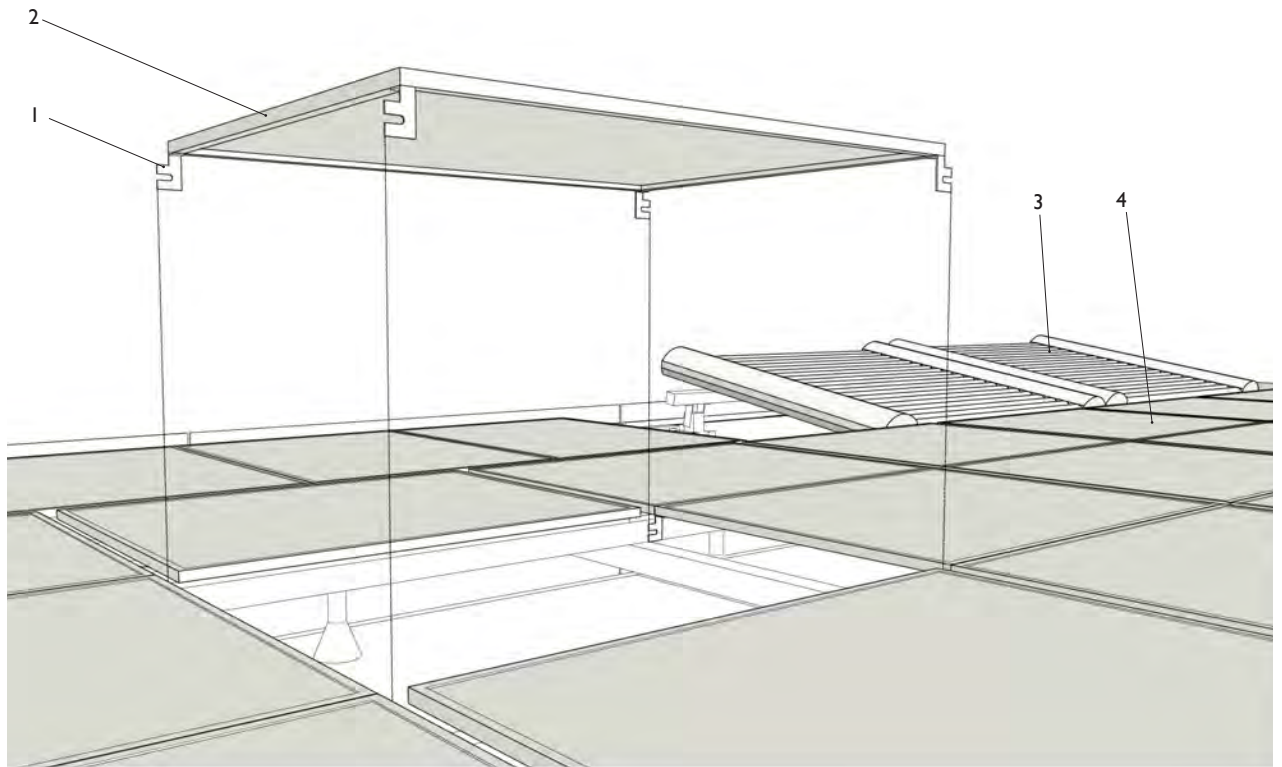


fig 2.14.3 installing the solar panels

fig 2.14.4



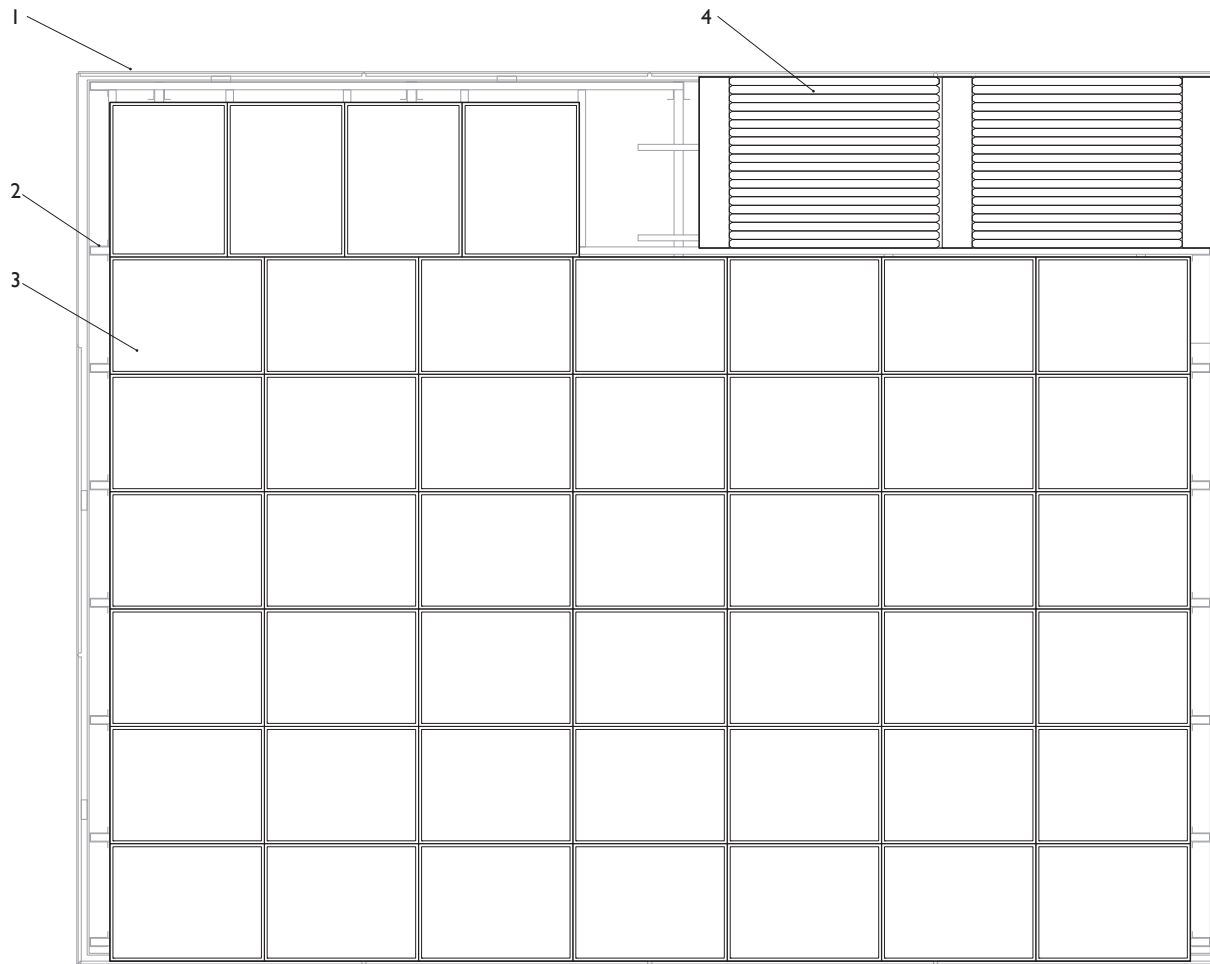


fig 2.14.5

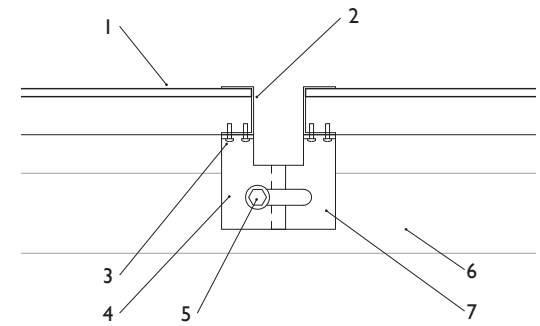


fig 2.14.6 solar panel bracket as installed

- 1 - solar panel
- 2 - aluminum frame of solar panels
- 3 - bracket bolted to frame
- 4 - brakeform steel bracket
- 5 - brackets bolted through purlin
- 6 - purlin (shown for reference)
- 7 - bracket as slid into position

fig 2.14.7
 close up of solar panel bracket as installed



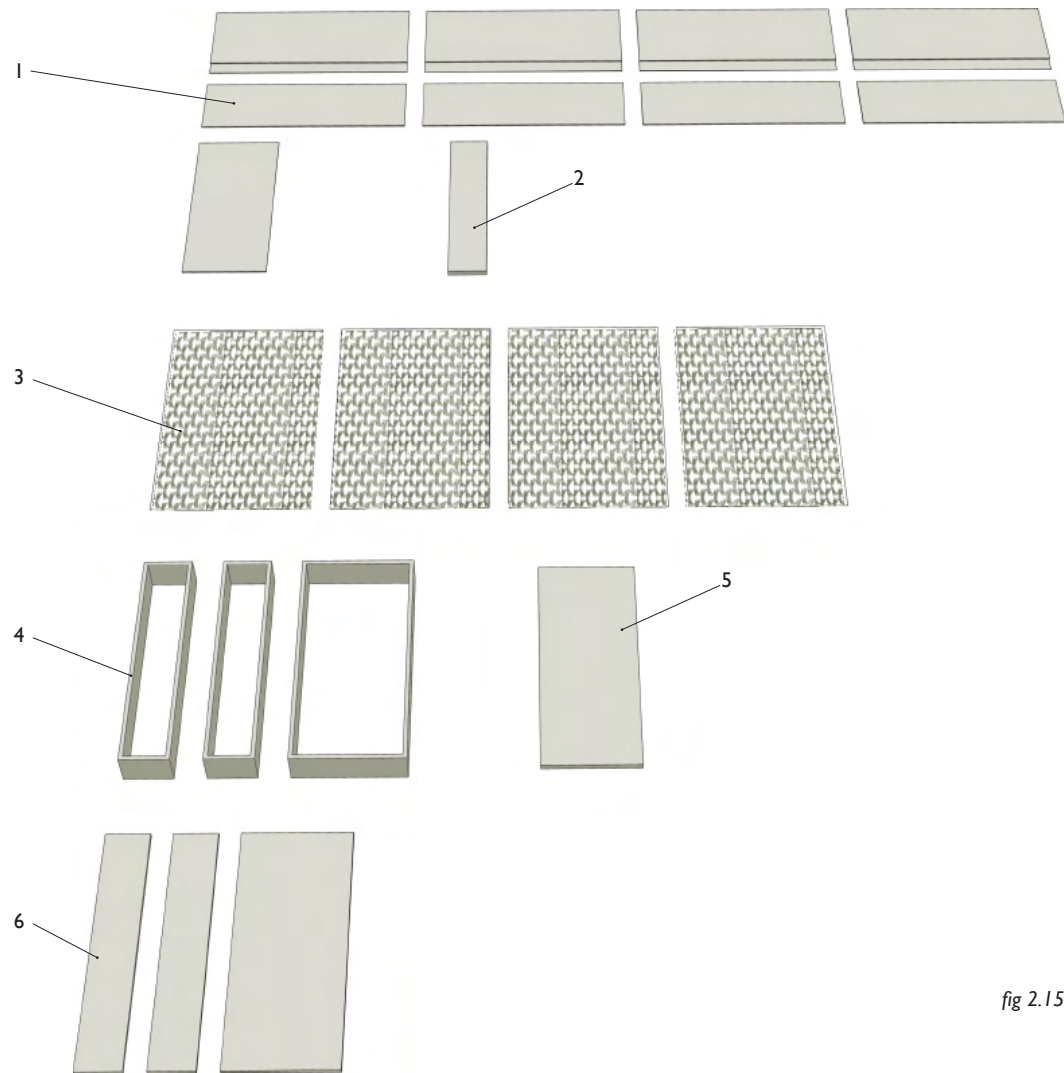
STEP 15: NORTH WALL

The North wall is clad in some areas with Crezon plywood panels, and in other with two panelized layers of metal mesh.

The plywood cladding panels are mounted using the QuadroClad façade system in an identical fashion to the BIPV cladding panels. Doors and windows should be installed in advance of the expanded metal cladding panels. A perforated metal panel provides partial concealment and easy access to the meter base located next to the North entrance.

The first layer of metal mesh cladding is perforated and powder coated. It conceals the AirBloc 33 UV resistant vapour permeable air and weather barrier membrane, on the opaque portions of the wall. The same material provides a door over the electrical meter base. The second layer is heavy-gauge expanded aluminum mesh which covers the first layer and also provides a screen over the shower window. The two layers of mesh are separated by metal standoffs, and are fastened to the north wall of the densepack.

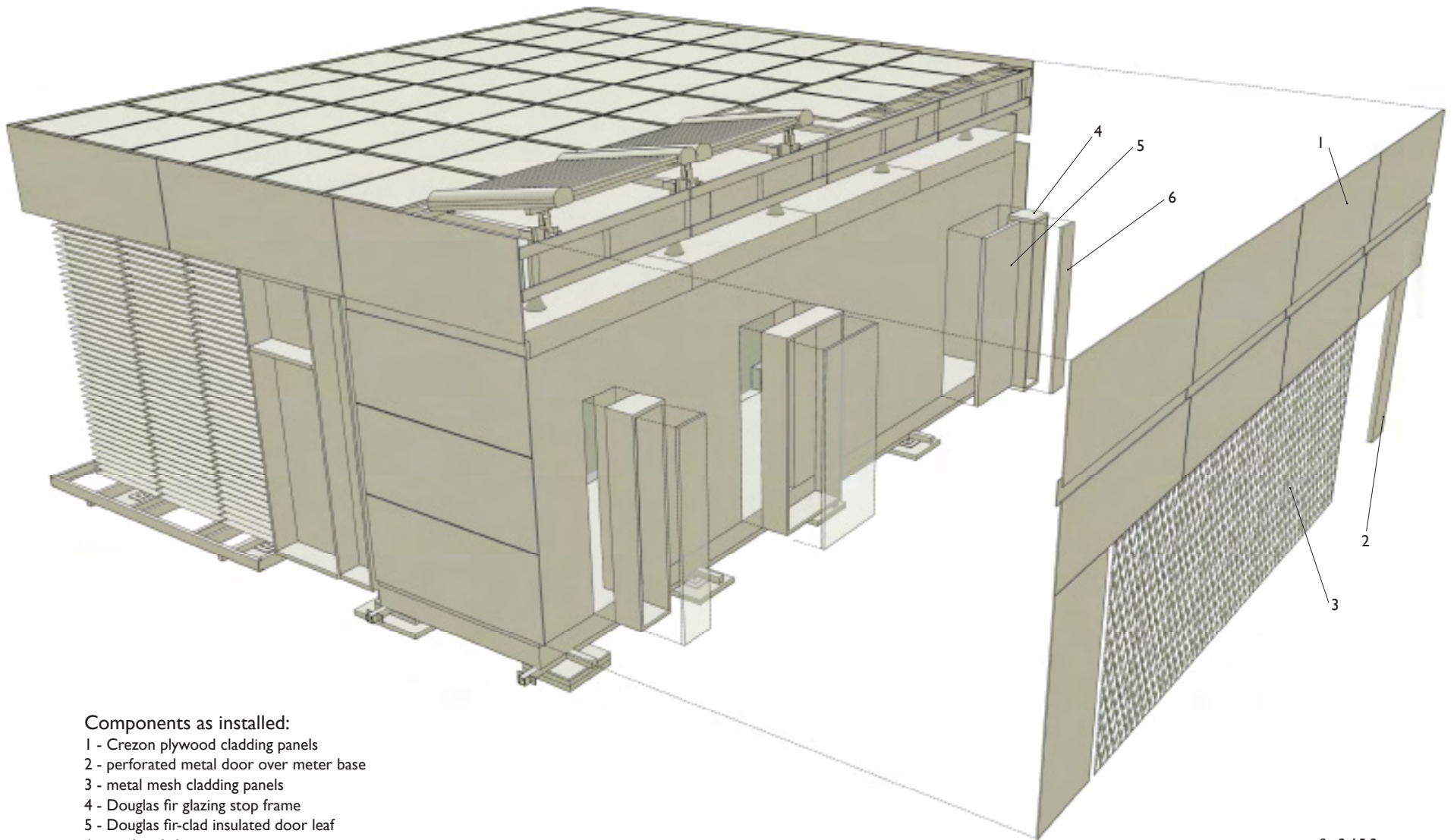
While door and window frames are pre-installed in the north wall of the densepack, the IGUs, glazing stops and the door leaf are not. The IGUs and glazing stops are installed from the inside of the densepack. Once the IGU is in place, the glazing stop, a Douglas-fir frame, is installed and mechanically fastened to the pre-installed window frame, holding the IGU in place.



Components installed during this step:

- 1 - 9 Crezon plywood cladding panels
- 2 - 1 perforated metal door over meter base
- 3 - 4 metal mesh cladding panels
- 4 - 3 Douglas fir glazing stop frames
- 5 - 1 Douglas fir-clad insulated door leaf
- 6 - 3 insulated glazing units

fig 2.15.1



- Components as installed:
- 1 - Crezon plywood cladding panels
 - 2 - perforated metal door over meter base
 - 3 - metal mesh cladding panels
 - 4 - Douglas fir glazing stop frame
 - 5 - Douglas fir-clad insulated door leaf
 - 6 - insulated glazing unit

fig 2.15.2

STEP 16: INTERIORS

Work on the interiors can begin as soon as the building is enclosed. This work can be divided into three main categories: the densepack, the kitchen and the ceiling.

Work in the densepack involves hanging glass doors, installing select millwork, and placing the suspended ceiling panels.

In the kitchen, once the Corian finish panels are installed, the Bulthaup cabinets are installed and the appliances are put in place and connected.

The suspended bed is then hung, and its mechanism calibrated before the living space ceiling is installed. Light fixtures on the living space ceiling are also installed at this time. This sculptural fabric ceiling consists of thousands of unique fabric cones, pre-assembled into large panels for easy installation. They are hung from eyelets pre-installed to the underside of the roof panels.

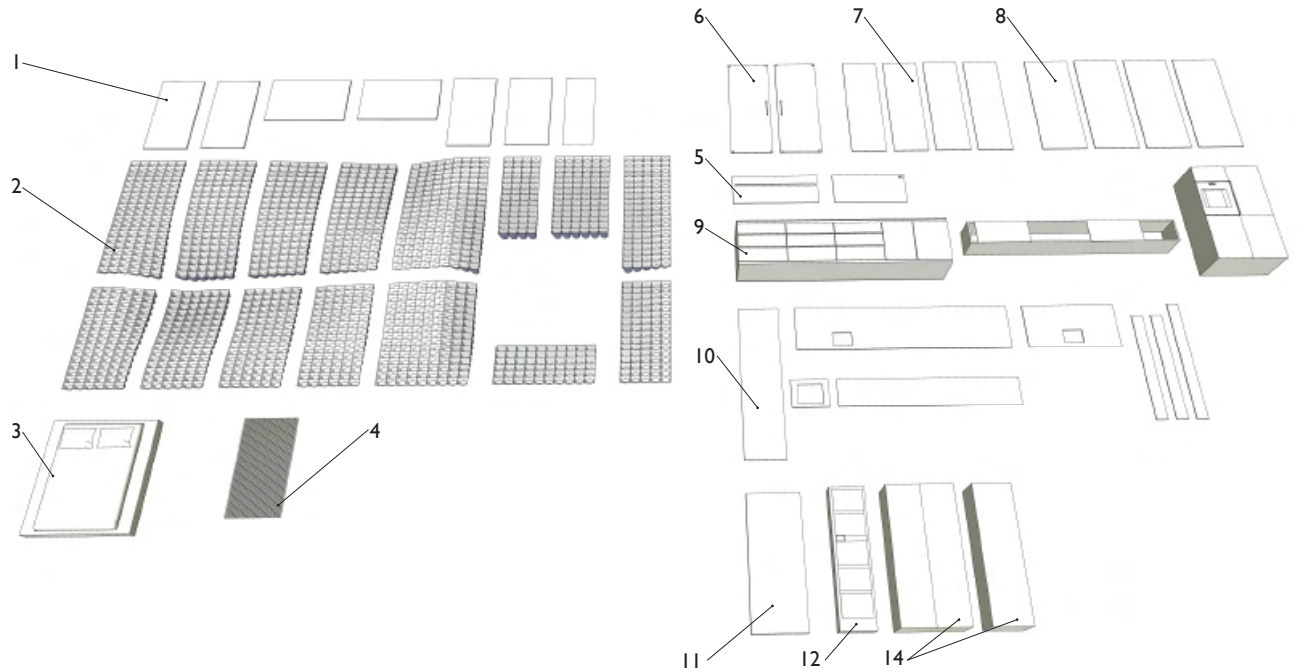
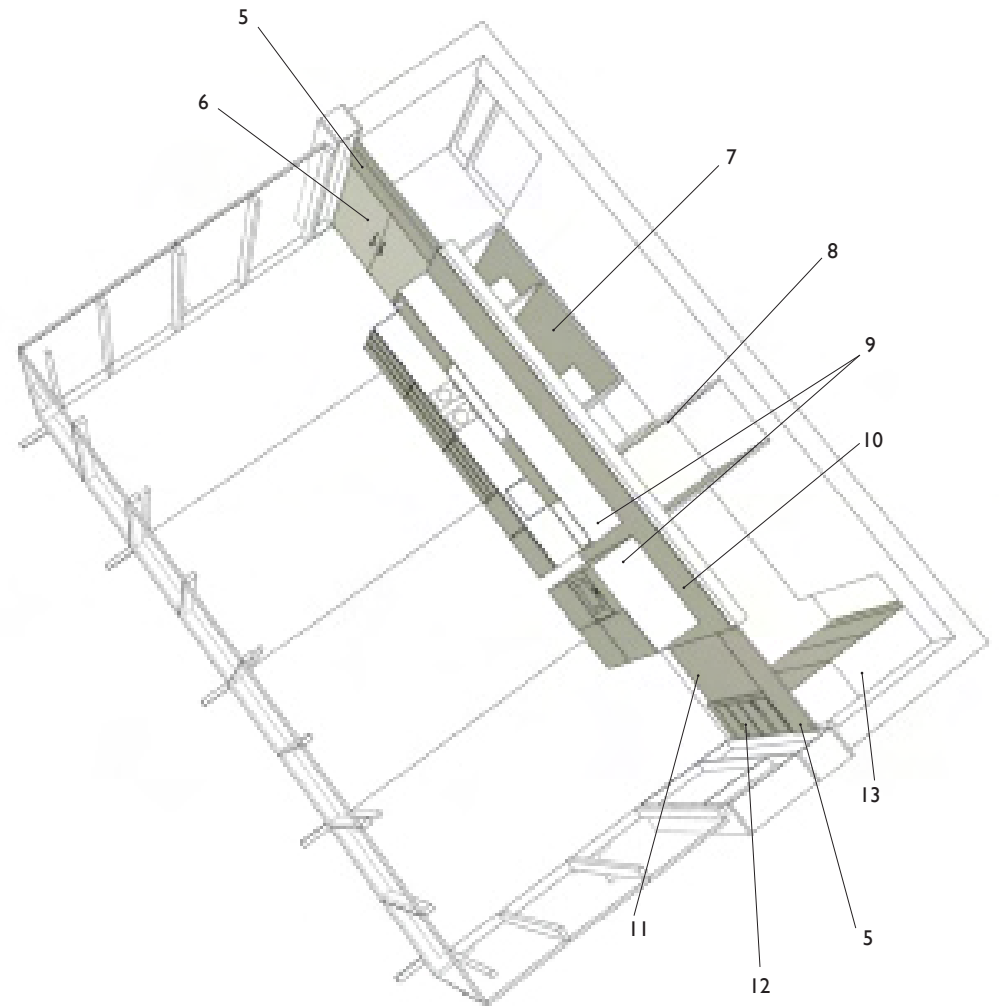
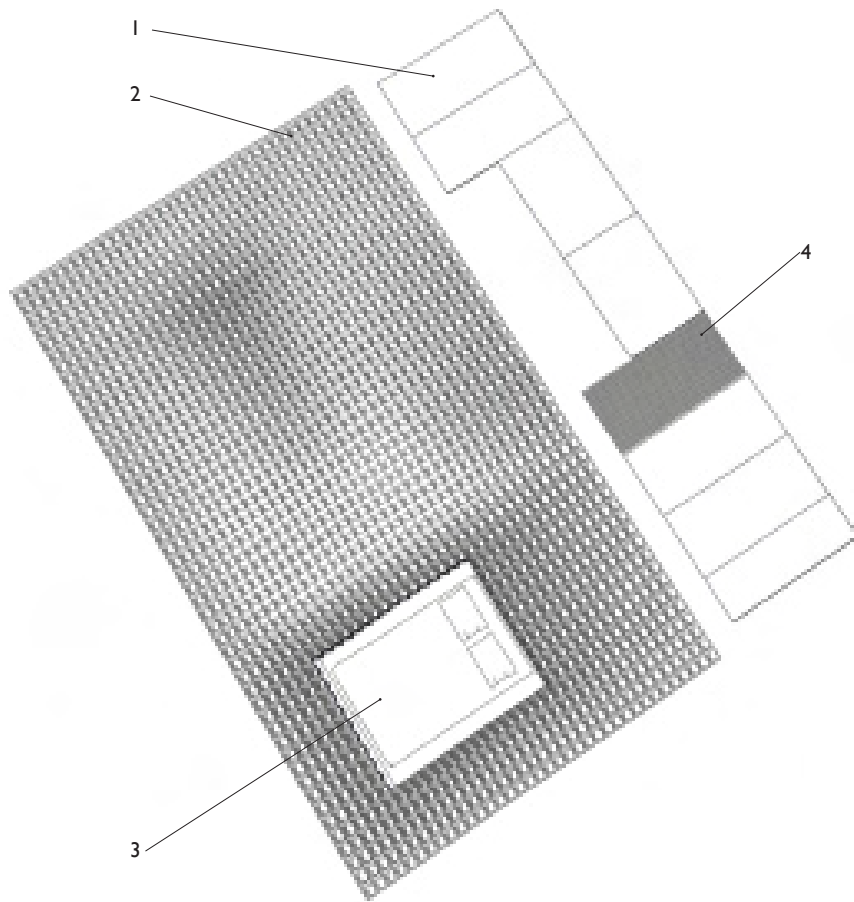


fig 2.16.1

Components installed during this step:

- | | |
|---|--|
| 1 - 7 Douglas fir acoustic ceiling panels | 8 - 4 glass doors in shower |
| 2 - 15 suspended sculptural ceiling panels | 9 - kitchen including appliances
(approx 16 pieces) |
| 3 - cable suspended bed (1 piece) | 10 - 8 Corian finish panels |
| 4 - maple slats above shower (1 piece) | 11 - 1 Douglas fir door |
| 5 - 2 Douglas fir transom panels | 12 - Douglas fir bookshelf (5 pieces) |
| 6 - 2 glass doors between densepack & living
space | 13 - Douglas fir storage closet (4 pieces) |
| 7 - 4 glass doors on mechanical closet | |



Components as installed:

- 1 - Douglas fir acoustic ceiling
- 2 - suspended sculptural ceiling
- 3 - cable suspended bed
- 4 - maple slats above shower
- 5 - Douglas fir transom panel
- 6 - glass doors between denspace & living space
- 7 - glass doors on mechanical closet
- 8 - glass doors in shower
- 9 - kitchen including appliances
- 10 - Corian finish
- 11 - Douglas fir door
- 12 - Douglas fir bookshelf
- 13 - Douglas fir storage closet

fig 2.16.2

STEP 17: EXTERIOR LANDSCAPE

The construction of the exterior landscape uses off-the-shelf scaffold parts as its base. The footings are similar to those that support the house, and these hold a framework of scaffold ledgers, onto which the cedar deck panels (also constructed with scaffold parts as substructure) can be placed. Like the substructure of the house, the separation of frame and panel allows the frame to be leveled before the panel is installed. Deck panels should be installed starting at the perimeter of the house, working outwards.

Planters of various types frame the deck, and a row of storage cabinets line the North of the site. They house the supply water, grey water, and black water tanks. Concealed beneath the deck is a heat rejection pond, which ships in three pieces and is assembled and levelled onsite.

Because of variations in grade, extra flexibility is required at the ends of the ramps. Checker plates are used to extend the ramps as necessary and to ensure they maintain a consistent slope as they meet the ground. The stairs at the North entrance are the only completely site built element. This is necessary because of unpredictable grade variation. Lastly, the canopy at the North Entrance, consisting of an aluminum frame and expanded aluminum mesh panels, is installed and anchored to the scaffold substructure.

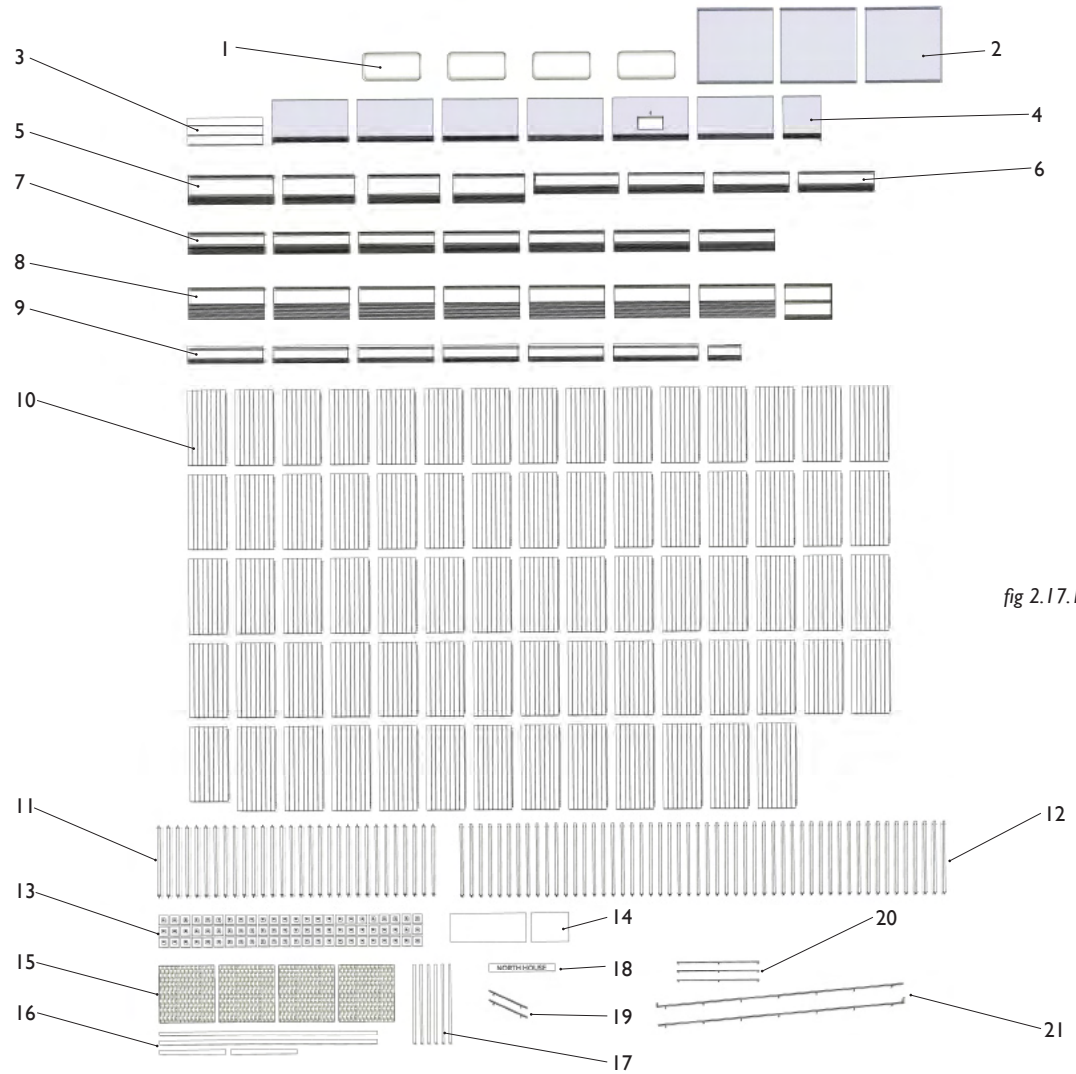


fig 2.17.1

Components as installed:

- | | | |
|---|--|--|
| 1 - 4 water storage tanks | 8 - 8 planters with cantilevered bench | 15 - 4 expanded metal mesh panels |
| 2 - heat rejection pond (3 pieces) | 9 - 7 low perimeter planter | 16 - 4 powder coated aluminum angle segments |
| 3 - site built stair (approx 11 pieces) | 10 - 73 cedar deck panels | 17 - 6 powder coated aluminum columns |
| 4 - 7 storage cabinets | 11 - 30 single ledger scaffold frame | 18 - 1 North House entry sign |
| 5 - 4 herb garden planters | 12 - 52 double ledger scaffold frame | 19 - 2 handrails at stair |
| 6 - 4 tall perimeter planters | 13 - 72 scaffold feet with cr bbing pads | 20 - 3 towel drying rails |
| 7 - 7 tall planters | 14 - 2 checker plates for base of ramps | 21 - 2 handrails at exit ramp |

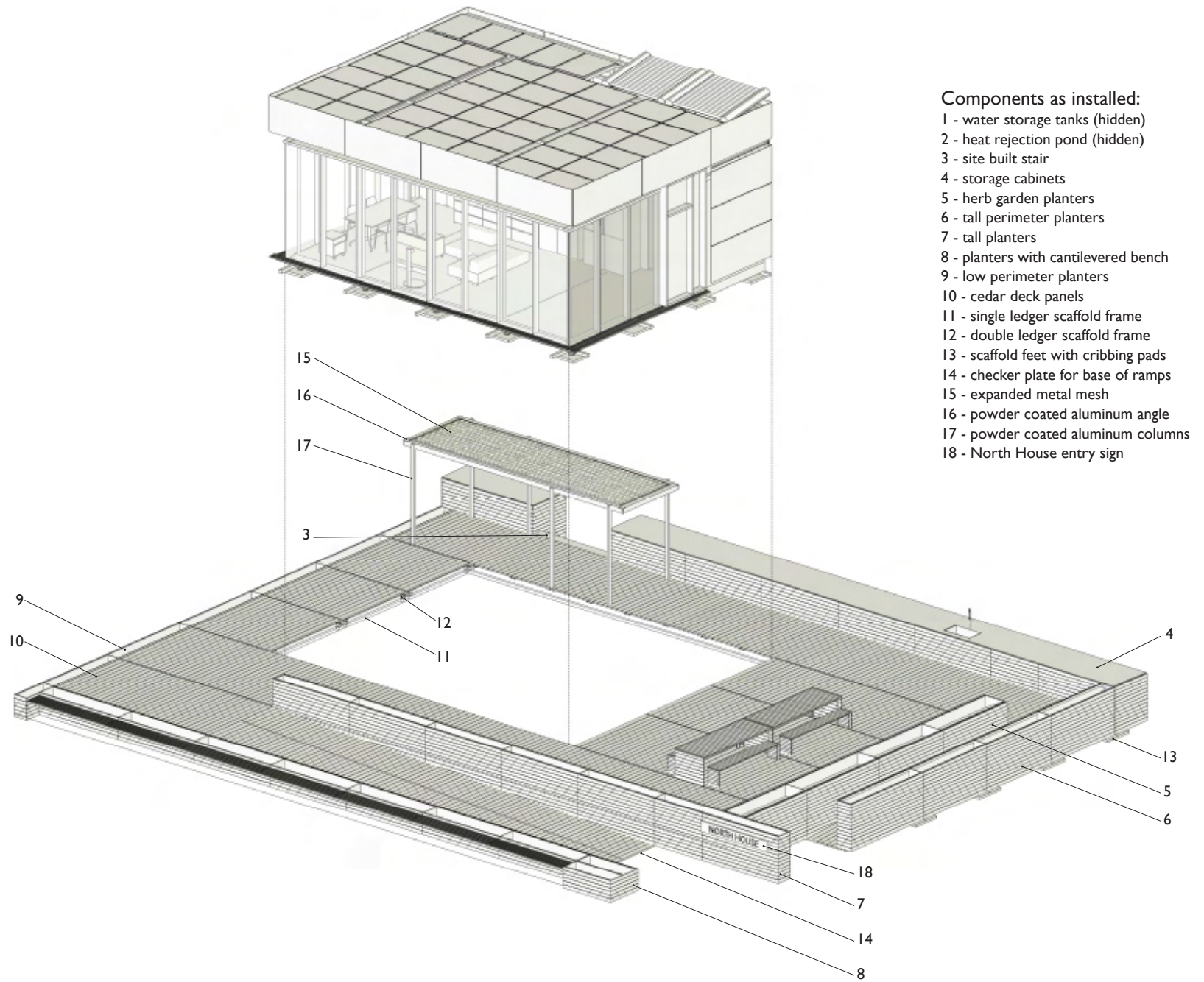


fig 2.17.2

NORTH HOUSE ON DISPLAY



fig 3.1 The National Mall at night



fig 3.2 The North House on the National Mall



fig 3.3 Interior view of living space



fig 3.4 Interior view of densepack

NORTH HOUSE ON DISPLAY

From October 8th to 18th of 2009, the North House was open to the public and the media on the National Mall in Washington D.C.. During this time the house was visited by 20,000 people, peaking at roughly 500 visitors per hour.

In addition to conducting public tours, Team North along with nineteen other teams, participated in ten contests which evaluated the houses both qualitatively and quantitatively:

Architecture was evaluated by a jury who judged the projects based on design and implementation as well as documentation.

The **Market Viability** contest was centered around the criteria of livability, buildability, marketability and accurate cost estimating.

The **Engineering** jury evaluated functionality, innovation and reliability as well as documentation.

Lighting Design was judged on the quality of electric and natural light, the ease of operation for the lighting controls, flexibility, energy efficiency, building integration as well as documentation.

The **Communications** contest evaluated teams websites and other promotional material, and also assessed the quality of the tours given to the public.

The **Comfort Zone** contest measured the interior temperature and humidity of the houses, and rated its ability to stay within a prescribed range.

The **Hot Water** contest tested the houses' ability to produce hot water at various times during the day and was intended to simulate typical washing and bathing tasks.

The **Appliances** contest monitored the performance of household appliances including the refrigerator, freezer, dishwasher and clothes washer and dryer. The frequency and parameters of their operation simulated typical conditions of an inhabited house.

The **Home Entertainment** contest simulated cooking, lighting and television-watching within the home. While objective measurements were taken to ensure that all of these systems were fully operational, the teams also hosted two dinner parties and a movie night which were judged by members of other teams.

The final and most heavily weighted competition was **Net Metering**. Instead of simply measuring the amount of energy produced, only surplus energy was counted, making the energy draw required to perform all of the tasks required for other contests an important factor in this contest.



fig 3.5 The north main entry with canopy



fig 3.6 View of living space with cable-suspended bed and exterior Venetian blinds



fig 3.7 The North House main entry at night



fig 3.8 The North House main entry during the day



fig 3.9 Front elevation at night with interior blinds



fig 3.10 Front elevation during the day with exterior blinds & visitors



fig 3.11 Southwest corner at night



fig 3.12 Southwest corner by day

DISASSEMBLY

DISASSEMBLY

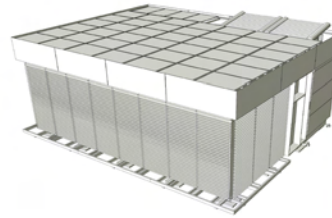
At 5:00pm on October 18th, after closing on the last day of public tours, the disassembly of the North House began. Because all of the connections that join the components of the North House together are completely reversible, the disassembly process closely resembles the assembly process in reverse. As with assembly, multiple activities can occur simultaneously during disassembly. As components were removed from the building they were packed and loaded on to trucks, ready to be reassembled in a new location.



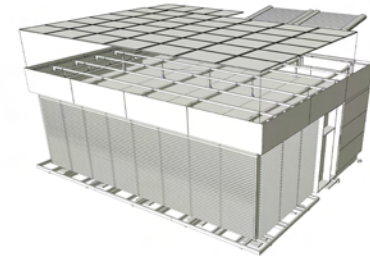


fig 4.1

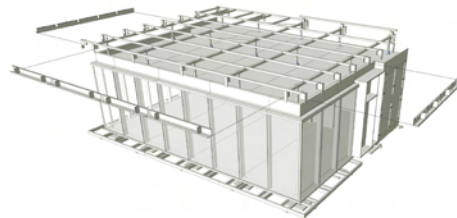
- 1 - begin disassembly
- 2 - unbolt and remove solar panels
- 3 - remove BIPV cladding using scaffold and hoist
- 4 - detach exterior blinds from brackets
- 5 - unbolt cladding supports
- 6 - unbolt blind supports
- 7 - unclip aluminum closer panels
- 8 - remove mullion caps and IGUs
- 9 - unscrew base support frames
- 10 - unscrew and disassemble mullion frames
- 11 - unbolt purlins and roof racking frames
- 12 - remove threaded rods through roof panels, unbolt columns and crane roof panels onto truck one at a time
- 13 - unbolt floor panels from substructure and crane panels onto truck one at a time
- 14 - crane densepack onto truck
- 15 - remove remaining footings to clear the site



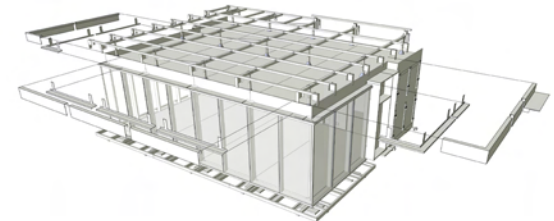
1



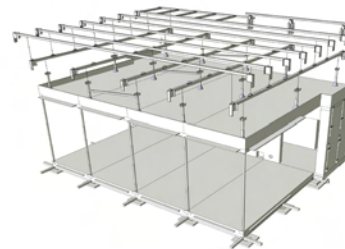
2



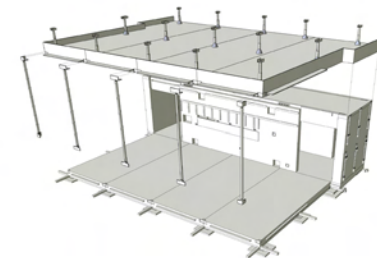
6



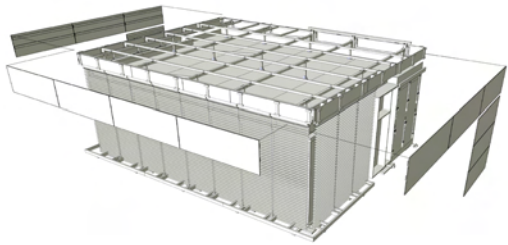
7



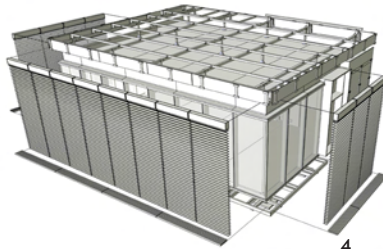
11



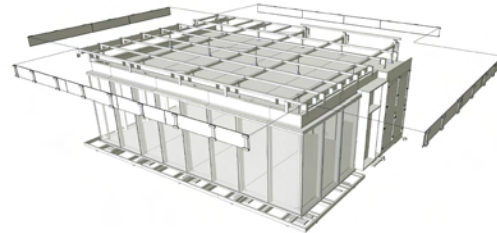
12



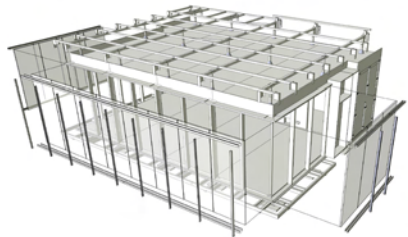
3



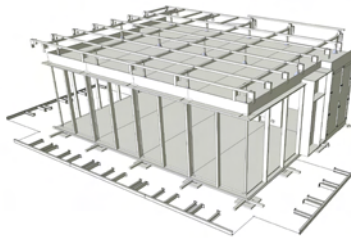
4



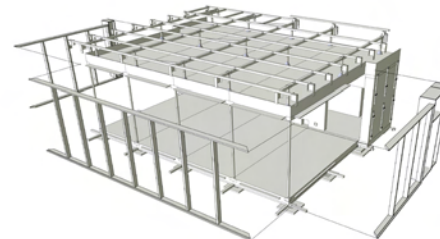
5



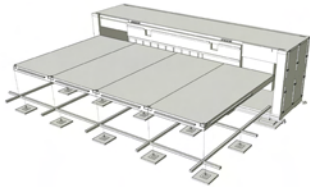
8



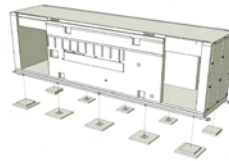
9



10



13



14



15

fig 4.2

CONCLUSION

REFLECTION / PROJECTION

The typical American House, as Kieran and Timberlake describe it, consists of more than 40,000 parts which come together, over a period of months, at a site to which they are anchored.¹⁸ The North House consists of approximately 476 parts (with an additional 385 for the exterior landscape), and can be assembled, inspected and balanced in under a week. Moreover, it can be disassembled in two days.

What can we learn from the example of the North House, and where might that knowledge take us next? The next section of this thesis explores the possibilities offered by the component-based architecture of the North House and anticipates the potential for their further application in other projects. This exploration is organized in terms of three qualities of component-based architecture: adaptability, off-site fabrication and demountability, with a focus on demountability as this is the most unusual quality of the North House prototype, and the quality least familiar to architectural discourse.

ADAPTABILITY

One primary goal of the North House project was to create a building that would act as a research laboratory to monitor long-term performance. Expanding on the built proof-of-concept prototype, its component-based design invites the potential for individual building elements or entire systems to be replaced for comparative monitoring. The current iteration of the North House could act as a control or baseline for monitoring the building's performance, and any modifications could be tested against that baseline, enabling researchers to provide concrete comparative data of a type that is normally very difficult to measure from built projects. It would also allow researchers to compare the predictions of energy modeling with real world findings. By comparing data generated by digital modeling software used to assess the building's performance such as TRNSYS, ESP-r, EnergyPlus, ECOTECH, WINDOW, THERM5 and WUFI, with data gathered from the long-term monitoring of the house's performance, one could gauge the accuracy of the software used, and identify discrepancies between digital and constructed conditions. This research would offer valuable data to the building industry. It would also allow researchers to compare the predictions of energy modeling with real-world findings. During the design development phase of the North House project, many option studies for the glazing system and the exterior shading device were investigated. In the future, these, and other alternates can be tested using the North House prototype. Solar technology is evolving quickly, and new products are coming to market all the time. It is also possible to replace the active solar systems, as more efficient ones become available. According to the National Renewable Energy Laboratory (NREL) the efficiency of the best research cells have increased from 27.6% in 1988 to 40.7% in 2008,¹⁹ and this trend is expected to continue.

Adaptability also has wide applications outside of its facilitation of research. As a residence, North House could expand or be reconfigured to meet the changing needs of its occupants. For example, additional rooms could be added to the prototype to accommodate families with children, or individuals who want space to work at home.

Similarly, these additions could be removed if the extra space was no longer required. The principles and techniques tested in the North House prototype, for example elements of the DReSS facade system, could also be applied to multi-unit residential buildings, or to commercial buildings. North House's component-based approach to construction facilitates the repair or replacement of components or systems without causing damage to any adjacent parts of the house. Adaptable buildings are sustainable buildings, because they have the ability to evolve along-side their inhabitants and to be retrofitted in order to maintain a life-long efficient performance, or for components with the shortest lifespan to be replaced. With this ease of repair and reconfiguration, adaptable buildings have a good chance of a long lifespan.

OFF-SITE FABRICATION

North House was built largely by a single fabricator, MCM 2001, Inc. Exceptions to this include the mechanical system, electrical system and the insulated glazing units. Through the collaboration of architect and fabricator, the process by which the house was manufactured and the strategies by which it could be assembled and disassembled, were customized to the needs of the team. The significant input and design on the part of the fabricator enabled the house to be easily built and assembled with the available expertise, machinery and man-power possessed by the team, and within the constrictive schedule imposed by the Solar Decathlon competition. While in Toronto at the manufacturing facilities of MCM 2001 Inc., the team had access to a workforce of up to 30 people at a time, and specialized equipment including full wood, metal and finish shops. Factory-building the components of the North House also served to greatly shorten the construction schedule by allowing for the simultaneous production of many components, by separate teams of fabricators. The fabrication phase of the project was limited to 10 weeks including all production and coordination of the shop drawings. As each component was completed it could be test fit and added to the building as it was gradually being assembled. When assembling the house in Washington, on the other hand, the team was limited to portable tools, and had a professional assembly team of twelve, who were assisted by students.

Building houses in factories has long been a dream of architects. As Jean Prouvé wrote in the 1940s, architecture lagged behind while “everything else in the world has been advancing at a rapid rate of industrialization.”²⁰ This is largely still true today.²¹ Factory-built houses could begin to approach the precision of construction and assembly that we see in automobiles and other mass produced products, along with a similar price reduction due to the rationalization and optimization of manufacturing and labour processes. If houses were mass produced, all of the details could be finely tuned and refined, and this superior product could be made affordable and widely available. Other advantages of factory-built houses, even if not mass produced, include the ability to decrease construction tolerances, reduce construction waste, and eliminate weather related delays. Because their process of manufacture uses resources effectively, minimizes waste and minimizes necessary transport of materials, equipment and people, buildings that are fabricated off-site have a significant potential to be sustainable buildings.

Finally, off-site mass production may be made more attractive by the contemporary notion of mass customization. In his 1993 work entitled *Mass Customization: The New Frontier of Business Competition*, Joseph Pine described the shift from mass production to mass customization and popularized it as a concept. Kieran and Timberlake describe it this way in relation to architecture:

*You have a choice. Build architecture the way Henry Ford showed you to build automobiles at the turn of the twentieth century - but, by the way you can only use one type of structure, one type of cladding, one type of interior finish, one type of exterior cladding. Or, build architecture the way Michael Dell builds his computers at the beginning of the twenty-first century, Use what is appropriate. Let the customers have it their way. And have it faster, better, and cheaper.*²²

Mass customization offers great potential for variety within a predetermined set of components, making factory-built houses even more commercially viable.

DEMOUNTABILITY

While a quick time frame for disassembly was a requirement of the Solar Decathlon, the utility of a demountable building does not end there. Disassembly rather than demolition enables components to be effectively reused or recycled at a building's end-of-life. Demountability also enables components to be 'swapped out' to extend high performance lifespans, and also makes them more suitable for adaptive reuse.²³

While still very uncommon in the building industry, Design for Disassembly (DfD) is a practice that is growing in popularity in product design. In Germany and Japan legislation is already in place requiring manufacturers to consider a design which allows components to be separated for efficient recycling.²⁴ The greatest hindrance to effective recycling is the inability to separate different materials from one another,²⁵ which often leads to an energy-intensive recycling process with the recovered material being of a significantly lower quality than the original materials used, or to materials being discarded altogether. In addition to DfD legislation, Extended Producer Responsibility (EPR) legislation makes producers responsible for the entire life-cycle of their products, further increasing the incentive to create products which are easy to reuse and recycle.

There are historical precedents for demountable buildings but they are relatively few, and were mainly used for applications of exhibition, as in the case of the North House, or for buildings required only for a short time, for temporary resource-extraction based communities, disaster relief or military applications. The Nissen Hut, for instance, precursor to the Quonset hut, was a temporary building used extensively by the British in World War One.²⁶ It was an ideal design for disassembly because it employed a small number of simple, interchangeable components that were mass produced, and could be assembled using simple tools. Another example is the temporary housing and barracks designed by Jean Prouvé and used in French colonies in Africa in the 1950s.²⁷ An innovative and widely publicized example of a demountable building which celebrated its component based design was Renzo Piano Building Workshop's design for the IBM Travelling Exhibition Pavilion. It was constructed out

of modular arches that created a barrel vault when connected together with wood ties.²⁸ The stage sets that Mark Fisher created for touring rock concerts are also notable because of their scale, technical complexity, and the speed with which they can be assembled and disassembled.²⁹

But beyond particular applications where disassemblable structures are demanded by their program, all buildings could benefit from the designers' consideration of their end-of-life scenario, whether for the whole building or any of its constituent parts. Recently, a few projects have been completed with the goal of facilitating building disassembly and materials reuse. In 1998 the Canada Mortgage and Housing Corporation (CMHC) published a manual, *Designing for Disassembly* by Vince Catalli. The work was born out of his firm's undertaking to deconstruct a 6000 square foot residential building and salvage all suitable materials for reuse. From this exercise he evaluated conventional residential construction in terms of ease of disassembly and established guidelines as well as revised building details to facilitate disassembly. The U.S. Environmental Protection Agency (EPA) undertook a similar project in 2003, deconstructing a house and reusing as much material as possible in a building constructed on the same site. Included in this project was a study comparing the cost of the building's deconstruction to the cost of its demolition. Surprisingly it concluded that if there are no hazardous materials that require increased caution and expensive procedures to remove safely, the cost of deconstruction is actually slightly less than the cost of demolition, even before considering any revenue generated from the reuse of recovered materials.³⁰ The EPA also funded the *DfD Case Study Home*, a new building designed to facilitate disassembly and adaptive reuse. This design featured repositionable interior walls, and a disentangled HVAC system.³¹ Several sets of guidelines for DfD have been attempted, among them are those prepared by Catalli, and a DfD design manual commissioned by the city of Seattle³², but one of the most concise and clear set of guidelines can be found in the work of Robert Bogue.*

136 tons of building-related construction and demolition waste is produced each year in the United States. The EPA has estimated that 92% of this waste is generated from renovation and demolition activities.³⁴ Unfortunately, only 20-30% of this waste is currently recycled. The amount of building-related waste is so great that in the U.S. it is estimated to be roughly equivalent to the volume of municipal solid waste landfilled every year.³⁵ It is imperative to maximize the portion of this waste that can be recycled, as this would not only prevent valuable resources from being sent to landfill, but it would also decrease the need for raw materials to be extracted and processed. The use of recycled and reused materials saves energy and produces fewer greenhouse gas emissions by cutting carbon associated with resource extraction, manufacturing, transportation and construction activities.³⁶

Architects' awareness of these issues is imperative, as design is the stage in a building's life where there is the greatest opportunity for effecting change. In their publication *Design for Disassembly in the Built Environment* the EPA assesses the impact of building-related waste, and reiterates the important role that design can play. According to *Final Report: Design for Deconstruction and Reuse* (prepared for the EPA by the University of Florida) the biggest obstacles to effective deconstruction of buildings lie in the initial design of a building, which today employs techniques which make disassembly and material reuse difficult, as well as with designers' failure to specify reused materials, ensuring a market for recovered products.³⁷ Designers have the ability to implement changes that are both relatively simple and inexpensive, and will effectively result in a significantly greater instance of building deconstruction and material reuse.

***SELECTED DfD GUIDELINES**

Product structure

- Create a modular design
- Minimize the component count
- Optimize component standardisation
- Minimize product variants

Materials

- Minimize the use of different materials
- Use recyclable materials
- Eliminate toxic or hazardous materials

Fasteners, joints and connections

- Minimize the number of joints and connections
- Make joints visible and accessible, eliminate hidden joints
- Use joints that are easy to disassemble
- Mark non-obvious joints
- Use fasteners rather than adhesives

Characteristics of components for disassembly

- Good accessibility
- Low weight
- Robust, minimize fragile parts
- Non-hazardous
- Preferably unpainted

Disassembly conditions

- Design for automated disassembly
- Eliminate the need for specialized disassembly procedures
- DfD with simple and standard tools³³

“If current housing replacement rates remain constant, approximately 41 million housing units will be demolished in the next 50 years, resulting in the creation of 3.3 billion tons of material debris. The complexity of building systems, quality and types of materials, and connecting devices used in post-1950s buildings make the recovery of materials for reuse and recycling extremely difficult. Buildings built after 1950, compared to pre-1950, often use a lesser percentage of wood; engineered lumber and composite materials; pneumatic nails instead of hand-driven nails; drywall in lieu of wood lathe and plaster; and plastics for siding, plumbing pipe, and other materials.

The housing to be designed and built from 2000 to 2050, in large part, will have materials that are infeasible for reuse and recycling and will be technically and economically prohibitive to adapt and disassemble with maximum materials recovery. If the next cycle of housing designed from 2000 to 2050 allowed for recovery of just 25% of their materials debris, these materials would be sufficient to build about two-thirds of the housing units built during the next 50 years. In order to address these environmental impacts, housing must be designed for near zero-waste and “closed-loop” materials management through design for disassembly of systems, components, and assemblies.”

— U.S. Environment Protection Agency, Solid Waste and Emergency Response (5101T), OSWER Innovations Pilot ³⁸

While the North House was not designed with the eventual dismantling and recycling of its components as a primary priority, it does satisfy many of the guidelines that have been established for DfD. In developing the design, the team made a considerable number of innovations in developing component system and in methods of joining them together, a significant part of the challenge of mainstreaming design for disassembly. The primary qualities of North house that make it ideal for design for disassembly are as follows:

All connections are completely reversible. Typically, bolts and screws were used instead of nails, and in special circumstances, other types of reversible connections were used. This includes threaded and sleeved connections between roof panels, friction fit mullion caps to hold the IGUs in place, a spring loaded clip connection for the aluminum closer panels, and a two part rail system for the BIPV cladding panels. All of these connections can easily be accessed, and can withstand repeated disassembly, leaving components in a suitable condition for reuse.

Components are made up of simple sub-assemblies. Many components of the North House consist of either a component assembly that is made of very few parts that are easy to separate, for example the substructure and footings, mullion frames, roof racking steel, base support frames and aluminum closer panels. These are all made up of components that are made of a single material. Alternately, many of North House’s complex component assemblies could be reusable without separation such as the solar panels, IGUs and exterior Venetian blinds.

Systems are disentangled from one another. The mechanical system is located almost entirely within the densepack and is easily accessed through removable ceiling panels. All wiring on the living space ceiling is surface mounted, and wiring for the solar array is exposed and accessible, making it easy to remove, alter or replace. The roof racking steel holds the active solar systems away from the insulated enclosure of the building, which is also independent of the substructure and footing system.

Other aspects of the North House’s design, however, are not in keeping with some of the guidelines proposed for DfD, and could present obstacles to material recovery and reuse. For example, exposed fasteners are recommended, while the North House has mainly concealed fasteners. One the other hand, as it has reversible connections, this could easily be overcome by providing an adequate explanation of how the building is to be disassembled. Other problematic elements include the house’s more complex components like the floor panels, which in addition to combining structure and insulation, have the finish flooring nailed to wood batons below making it and the phase change material below it difficult to remove. The roof panels, and the densepack combine different materials in ways that make them similarly difficult to separate. There are also elements which are finished in such a way that might discourage their reuse or recycling, or at least complicate it, as the finish would be difficult to remove. These include powder coated metal elements such as the aluminum closer panels and the steel columns. All exterior steel is coated with a zinc rich primer, and all of the wood elements are finished.

Overall, North House meets the majority of the design for disassembly principles, and most of its components could feasibly be reused or recycled at its end-of-life.

EXTENDED PRODUCER RESPONSIBILITY

A prefabricated demountable building like the North House which was built primarily by a single manufacturer, is a significant step towards factory made buildings with Extended Producer Responsibility. EPR requires manufacturers to be responsible for their products throughout the product life-cycle.³⁹ Essentially, exactly what Buckminster Fuller intended for his Dymaxion houses as far back as 1927.⁴⁰ The key incentives behind EPR are to promote more sustainable design practices, by shifting the responsibility for the entire product life-cycle (especially end-of-life) to the producer, rather than placing that responsibility on the consumer, or the government. This is intended to improve the quality of product design to minimize the use of hazardous materials, and materials which are difficult to reuse or dispose of safely, and to ensure that materials are used and reused more efficiently. It can also present a valuable economic incentive for manufacturers to find ways to incorporate recycled and reused materials into new products. The North American group Clean Production Action outlines key principles that make EPR successful in their paper entitled *How Producer Responsibility for Product Take-Back can promote eco-design*.^{*} EPR and product take-back laws are currently gaining in popularity, especially in automotive, electronic and packaging industries. These industries have been targeted for EPR because they create a large portion of the waste stream, and contain valuable and potentially hazardous materials, qualities that they share with building industry waste. If we as architects desire to pursue factory built buildings, we should consider EPR, and strive to design processes of manufacture that can incorporate historic building waste (demolition waste from existing buildings), and create buildings that can provide valuable, useable materials back to the fabricator at their end-of-life.

THE DESIGN OF MANUFACTURE

The greatest advantages of component-based building can be seen when the three categories of adaptability, off-site fabrication and demountability are considered together. North House was constructed as a one-off proof-of-concept prototype. If we consider the possibilities of mass production and mass customization, the prospect of adaptable housing becomes more feasible. Repairs would take on the character of automotive repairs, where the defective part could be replaced with a readily available spare part, without affecting any adjacent components. Additions or renovations could happen swiftly, adding off-the-shelf components, and returning components that are no longer required, to the manufacturer.

Instead of architects aspiring to an assembly line for buildings similar to that of the automotive industry's past, we should look to the future of automotive and product design, and design building systems where in addition to being component-based, the components themselves can be disassembled for maximum recycling and reuse. The real design challenge then lies not just in the design of the building, but in the design of its manufacture, and projected lifecycle. Included in this design challenge is the need to anticipate how building materials can be repurposed in a way that provides valuable resources back to the manufacturer or other industrial agents. Through the collaboration of fabricators and architects on the design of both the building and its process of manufacture, a building product could be created which would be maximally adaptable, giving it a long lifespan, and allowing it to be fully disassembled at the end of its life with the greatest possibility for the reuse and the recycle of its component parts.

*SELECTED EPR GUIDELINES

- *The responsibility for a product at its end of life must clearly be on the producer of that product.*
- *Producers must be responsible for their own products (and not for a general portion of the market share) – this encourages incentive for producers to implement environmentally sound principles, and to design for ease of disassembly, reuse and recycling*
- *The full life-cycle cost of the product (or subcomponents of that product) are embedded in the retail price – this gives a competitive advantage to materials that are easy to deal with at the end-of-life, and decreases the use of hazardous materials due to the additional expense of handling them at the product's end-of-life*
- *High rates of recycling are mandated and producers must be responsible for achieving these rates.⁴¹*

NOTES

NOTES

1. Weatherbase: Historical Weather for Toronto, Ontario, <http://www.weatherbase.com/weather/weather.php3?s=042617&refer=> .
2. Kathy Velikov and Lyn Bartram, “North House: Developing Intelligent Building Technology and User Interface in Energy Independent Domestic Environments”(Paper Presented at the Passive and Low Energy Architecture Conference PLEA 2009: Architecture, Energy and the Occupant’s Perspective, Quebec City, June 22-24 2009).
3. Georgina Foley, and Living Steel, *Houses of Steel: Living Steel’s international architecture competitions* (Images Publishing, Mulgrave, Vic: 2009).
4. U.S. Department of Energy: Solar Decathlon Rules 2009. Rule 8-7.
5. U.S. Department of Energy: Solar Decathlon, “About the Solar Decathlon,” <http://www.solardecathlon.org/about.cfm>.
6. Beatriz Colomina, “The Exhibitionary House,” in *At the end of the Century One Hundred Years of Architecture*, edited by Russell Ferguson (Los Angeles: The Museum of Contemporary Art, Los Angeles, 1998), 129.
7. Ibid, 151.
8. Amy Lelyveld, “A Brave New Home: Breuer’s House in the Museum Garden,” in *Marcel Breuer American Houses*, edited by Monica Gili (Barcelona: Editorial Gustavo Gili, SA, 2001), 140.
9. Tag Gronberg, “Speaking Volumes: The “Pavillon de l’Esprit Nouveau”,” *Oxford Art Journal* 15, No.2 (1992): 58–69.
10. Beatriz Colomina, “The Exhibitionary House,” in *At the end of the Century One Hundred Years of Architecture*, edited by Russell Ferguson (Los Angeles: The Museum of Contemporary Art, Los Angeles, 1998), 143.
11. Arts & Architecture. Arts & Architecture Mag: the Case Study House Program, <http://www.artsandarchitecture.com/case.houses/index.html>.
12. John McHale, *R. Buckminster Fuller* (New York: G. Braziller, 1962), 27.
13. Ibid, 22.
14. Stephen Kieran and James Timberlake, *Loblolly House Elements of a New Architecture* (New York: Princeton Architectural Press, 2008), 143.
15. Barry Bergdoll and Peter Christensen, eds., *Home Delivery Fabricating the Modern Dwelling* (New

- York: The Museum of Modern Art, 2008), 226.
16. Stephen Kieran, and James Timberlake, *Loblolly House Elements of a New Architecture* (New York: Princeton Architectural Press, 2008), 100.
 17. Ibid, 57.
 18. Ibid, 23.
 19. NREL Photovoltaic Research, Best Research-Cell efficiencies, http://www.nrel.gov/pv/thin_film/docs/kaz_best_research_cells.ppt.
 20. Jean Prouvé, “We need factoryed houses”, *The Poetics of the Technical Object* (Weil am Rhein, Germany: Vitra Design Museum, 2005), 176.
 21. Stephen Kieran and James Timberlake, *Refabricating Architecture: How Manufacturing Methodologies are Poised to Transform Building Construction* (New York: McGraw-Hill, 2004), 105.
 22. Ibid, 133.
 23. U.S. Environment Protection Agency. Solid Waste and Emergency Response (5101T). *Oswer Innovations Pilot, Design for Disassembly in the Built Environment*. EPA 500-F-04-025 July 2004, www.epa.gov/oswer/iwg.
 24. *German end-of-life vehicle act, 2002 & Japanese end-of-life vehicle recycling initiative, 1996*
 25. William McDonough and Michael Braungart, *Cradle to Cradle* (New York: North Point Press, 2002), 99.
 26. Robert Kronenburg, *Portable Architecture* 3rd Edition (Oxford; Burlington MA: Architectural Press, 2003), 3.
 27. Robert Rubin, “About Jean Prouvé’s Tropical House”, http://hammer.ucla.edu/exhibitions/detail/exhibition_id/105.
 28. Ziyang Po, “IBM Traveling Pavilion by Renzo Piano,” <http://ziyangpoharchitecture.blogspot.com/2009/11/ibm-pavilion.html>.
 29. Robert Kronenburg, *Portable Architecture* 2nd Edition (Oxford; Boston: Architectural Press, 2000), 112.
 30. Powell Center for Construction and Environment, “Final Report: Design for Deconstruction and Reuse Distillation of a Home,” the US EPA Office of Solid Waste and Emergency Response, <http://www.unbuild-rebuild.org/pdfs/Dfr03-20.pdf>.

31. U.S. Environment Protection Agency Solid Waste and Emergency Response, “Oswer Innovations Project Success Story: Deconstruction,” www.epa.gov.
32. DFD Seattle, Lifecycle Building Challenge. “Dfd Design for Disassembly in the built environment: a guide to closed-loop design and building,” <http://www.lifecyclebuilding.org/files/DfdSeattle.pdf>.
33. Robert Bogue, “*Design for Disassembly: a critical twenty-first century discipline*” *Assembly Automation* Volume 27, Number 4 2007. p. 288.
34. U.S. Environment Protection Agency, Solid Waste and Emergency Response (5101T), *Oswer Innovations Pilot, Deconstruction and Building with Reused Materials Training*, EPA 500-F-05-014, www.epa.gov/oswer/iwg.
35. David Malin Roodman and Nicholas Lenssen, “*A Building Revolution: How Ecology and Health Concerns Are Transforming Construction*,” *Worldwatch* Paper 124 (Washington, DC: Worldwatch Institute, March 1995), p. 24.
36. U.S. Environment Protection Agency, Solid Waste and Emergency Response (5101T), *OSWER Innovations Pilot, Deconstruction and Building with Reused Materials Training*, EPA 500-F-05-014, www.epa.gov/oswer/iwg.
37. Powell Center for Construction and Environment, “Final Report: Design for Deconstruction and Reuse Distillation of a Home,” the US EPA Office of Solid Waste and Emergency Response, <http://www.unbuild-rebuild.org/pdfs/DfR03-20.pdf>.
38. U.S. Environment Protection Agency, Solid Waste and Emergency Response (5101T), *OSWER Innovations Pilot, Deconstruction and Building with Reused Materials Training*, EPA 500-F-05-014, www.epa.gov/oswer/iwg.
39. Office for Economic Co-operation and Development, http://www.oecd.org/document/53/0,3343,en_2649_34395_37284725_1_1_1_1,00.html.
40. John. R. McHale. *Buckminster Fuller*. New York: G. Braziller, 1962.
41. Clean Production Action. *How Producer Responsibility for Product Take-Back Can Promote Eco-Design..* http://cleanproduction.org/pdf/cpa_ecodesign_Apr08.pdf (accessed Feb 6, 2010).

BIBLIOGRAPHY

SELECTED BIBLIOGRAPHY

- Anderson, Mark and Peter. *Prefab Prototypes Site Specific Design for Offsite Construction*. New York: Princeton Architectural Press, 2007.
- Arieff, Allison, and Bryan Burkhart. *PREFAB*. Salt Lake City: Gibbs Smith, 2002.
- Arts & Architecture. Arts & Architecture Mag: the Case Study House Program. <http://www.artsandarchitecture.com/case.houses/index.html> (accessed Jan 24, 2010).
- Bahamon, Alejandro, ed. *Prefab: adaptable, modular, dismountable, light, mobile architecture*. New York: Loft Publications S.L.: 2002.
- Banham, Reyner. *The architecture of the well-tempered environment*. Chicago: University of Chicago Press, 1984.
- Bergdoll, Barry and Christensen, Peter eds. *Home Delivery Fabricating the Modern Dwelling*. New York: The Museum of Modern Art, 2008.
- Robert Bogue, “Design for Disassembly: a critical twenty-first century discipline” *Assembly Automation* Volume 27, Number 4 2007. p. 288.
- Buchanan, Michael. *Prefab Home*. Salt Lake City: Gibbs Smith, 2004.
- Catalli, Vince and Maria Williams. “Designing for Disassembly.” *Canadian Architect*, January, 2001, <http://www.canadianarchitect.com/issues/ISarticle.asp?aid=1000149177>.
- Catalli, Vince. “Design for Disassembly: Early planning means an economic afterlife for buildings.” *SAB*, October 27, 2009, <http://www.sabmagazine.com/blog/2009/10/27/design-for-disassembly/#more-533>.
- Colomina, Beatriz. “The Exhibitionary House.” In *At the end of the Century One Hundred Years of Architecture*. Edited by Russell Ferguson, 126–166. Los Angeles: The Museum of Contemporary Art, Los Angeles, 1998.
- Clean Production Action. *How Producer Responsibility for Product Take-Back Can Promote Eco-Design*. http://cleanproduction.org/pdf/cpa_ecodesign_Apr08.pdf (accessed Feb 6, 2010)
- Decker, Julie and Chris Chiei. *Quonset Hut: Living for a Modern Age*. New York: Princeton Architectural Press, 2005.

- DFD Seattle. Lifecycle Building Challenge. "Dfd Design for Disassembly in the built environment: a guide to closed-loop design and building." <http://www.lifecyclebuilding.org/files/DfDseattle.pdf> (accessed Feb 3, 2010).
- Foley, Georgina, and Living Steel. *Houses of Steel: Living Steel's international architecture competitions*. Mulgrave, Vic: Images Publishing, 2009.
- Fuller, Buckminster, and Robert Marks. *The Dymaxion World of Buckminster Fuller*. Garden City; New York: Anchor Press, 1973.
- Gibb, Alistair G.F.. *Off-Site Fabrication: Prefabrication, Pre-Assembly and Modularisation..* Caithness, Scotland: Whittles Publishing, 1999.
- Gorman, Michael John. *Buckminster Fuller: Designing for Mobility*. London: Thames & Hudson, 2005.
- Gresleri, Giuliano. *L'Esprit Nouveau*. Milan: Electa, 1979.
- Gronberg, Tag. "Speaking Volumes: The "Pavillon de l'Esprit Nouveau"." *Oxford Art Journal* 15, No.2 (1992): 58–69.
- Kieran, Stephen, and James Timberlake. *Refabricating Architecture: How Manufacturing Methodologies are Poised to Transform Building Construction*. New York: McGraw-Hill, 2004.
- Kieran, Stephen, and James Timberlake. *Loblolly House Elements of a New Architecture*. New York: Princeton Architectural Press, 2008.
- Kronenburg, Robert. *Portable Architecture 2nd Ed*. Oxford; Boston: Architectural Press, 2000.
- *Houses in Motion: The Genesis, History and Development of the Portable Building 2nd Ed*. West Sussex, UK: Wiley-Academy, 2002.
- *Transportable Environments*. London; New York: Spon Press, 2002.
- *Portable Architecture 3rd. Ed*. Elsevier . 2003.
- Lelyveld, Amy. "A Brave New Home: Breuer's House in the Museum Garden." In *Marcel Breuer American Houses*, edited by Monica Gili, 138–143. Barcelona: Editorial Gustavo Gili, SA, 2001.
- McDonough, William, and Michael Braungart. *Cradle to Cradle*. New York: North Point Press, 2002.
- McHale, John. R. *Buckminster Fuller*. New York: G. Braziller, 1962.
- Mostaedi, Arian. *Great Spaces: Flexible Homes*. Barcelona: Links, 2006.

- NREL Photovoltaic Research, Best Research-Cell efficiencies. http://www.nrel.gov/pv/thin_film/docs/kaz_best_research_cells.ppt (accessed Jan 20, 2010).
- Office for Economic Co-operation and Development. *Fact Sheet: Extended Producer Responsibility* http://www.oecd.org/document/53/0,3343,en_2649_34395_37284725_1_1_1_1,00.html (accessed Jan 14, 2010).
- Pine, B. Joseph II. *Mass Customization: The new frontier in business competition*. Boston: Harvard Business School Press, 1993.
- Po, Ziyang, "IBM Traveling Pavilion by Renzo Piano," <http://ziyangpoharchitecture.blogspot.com/2009/11/ibm-pavilion.html> (accessed Feb 3, 2010).
- Powell Center for Construction and Environment. "Final Report: Design for Deconstruction and Reuse Distillation of a Home." The US EPA Office of Solid Waste and Emergency Response, <http://www.unbuild-rebuild.org/pdfs/DfR03-20.pdf> (accessed February 5, 2010).
- Prouvé, Jean. "We need factoryed houses." *The Poetics of the Technical Object*. Weil am Rhein, Germany: Vitra Design Museum, 2005.
- Robert Rubin, "About Jean Prouvé's Tropical House." http://hammer.ucla.edu/exhibitions/detail/exhibition_id/105 (accessed Jan 24, 2010),
- Roodman, David Malin, and Nicholas Lenssen, "*A Building Revolution: How Ecology and Health Concerns Are Transforming Construction*," Worldwatch Paper 124 (Washington, DC: Worldwatch Institute, March 1995), p. 24.
- Seguin, Patrick. *Jean Prouvé*. New York: Sonnabend Gallery, 2007.
- Siegal, Jennifer. *MOBILE: The art of Portable Architecture*. New York: Princeton Architectural Press, 2002.
- *More Mobile: Portable Architecture for today*. New York: Princeton Architectural Press, 2008.
- Scortes, Christopher. *LOT-EK: Mobile Dwelling Unit*. New York: D.A.P., 2003.
- Sparke, Penny, Brenda Martin, and Trevor Keeble. *The Modern Period Room: The construction of the exhibited interior 1870 to 1950*. London; New York: Routledge, 2006.
- Staib, Gerald, Andreas Dorrhofer, and Markus Rosenthal. *Components and Systems / Modular Construction*. Munich: Edition Detail, 2008.
- Taschen, Angelika, ed. *Prefab Houses*. New York: Taschen America, 2009.

- Thün, Geoffrey, Philip Beesley, Kathy Velikov, Robert F. Woodbury, eds.. *North House Team North: Entry to the Solar Decathlon*. Waterloo: Riverside Architectural Press, 2008.
- Topham, Sean. *Move House*. Munich; New York, 2004.
- Trulove, James G. *PreFab Now*. New York: Collins Design, 2007.
- U.S. Department of Energy: Solar Decathlon. "About Solar Decathlon." <http://www.solardecathlon.org/about.cfm> (accessed January 9, 2010).
- U.S. Department of Energy: Solar Decathlon. "Rules." http://www.solardecathlon.org/pdfs/sd2009_rules.pdf (accessed January 9, 2010).
- U.S. Environment Protection Agency. Solid Waste and Emergency Response (5101T). *Oswer Innovations Pilot, Design for Disassembly in the Built Environment (EPA 500-F-04-025 July 2004)*, www.epa.gov/oswer/iwg (accessed January 9, 2010).
- Velikov, Kathy, and Lyn Bartram. "North House: Developing Intelligent Building Technology and User Interface in Energy Independent Domestic Environments." Paper Presented at the Passive and Low Energy Architecture Conference PLEA 2009: Architecture, Energy and the Occupant's Perspective, Quebec City, June 22-24 2009.
- Weatherbase: Historical Weather for Toronto, Ontario, <http://www.weatherbase.com/weather/weather.php?s=042617&refer=> (accessed Jan 24, 2010).

BUILDING CODES

U.S. Department of Energy: Solar Decathlon 2009 Rules. Version 1.2. September 29, 2008.

U.S. Department of Energy: Solar Decathlon 2009 Building Code. Version 1.0. September 3, 2009.

International Code Council. 2006 International Residential Code.

Ministry of Municipal Affairs and Housing, Building and Development Branch. 2006 Ontario Building Code.

PRODUCT DATA

Alumicor. 2500 Series stick curtain wall system. <http://www.alumicor.com/products/curtainwall/stickbuilt/curtainwall2500.php> (accessed Feb. 6, 2010).

Amico. Expanded metal. <http://amico-grating.com/expanded-metal.htm> (accessed Feb. 6, 2010).

Bakor. Air-bloc 33. <http://www.bakor.com/data/datasheets/AirBloc33.pdf> (accessed Feb. 6, 2010).

Bakor. Blueskin. <http://www.bakor.com/data/datasheets/BlueskinSA.pdf> (accessed Feb. 6, 2010).

Bulthaup. Products, system b1. <http://www.bulthaup.com/bulthaup/internet/en/home.nsf/contentview/7E0E2B959074F1ADC12573AD00543ACC> (accessed Feb. 6, 2010).

Canadian general tower. Roofing membrane. http://www.cgtower.com/ind_roofing.htm (accessed Feb. 6, 2010).

Cosella Dorken. Delta-Cool 24. <http://www.cosella-dorken.com/bvf-ca-en/products/pcm/products/cool24.php> (accessed Feb. 6, 2010).

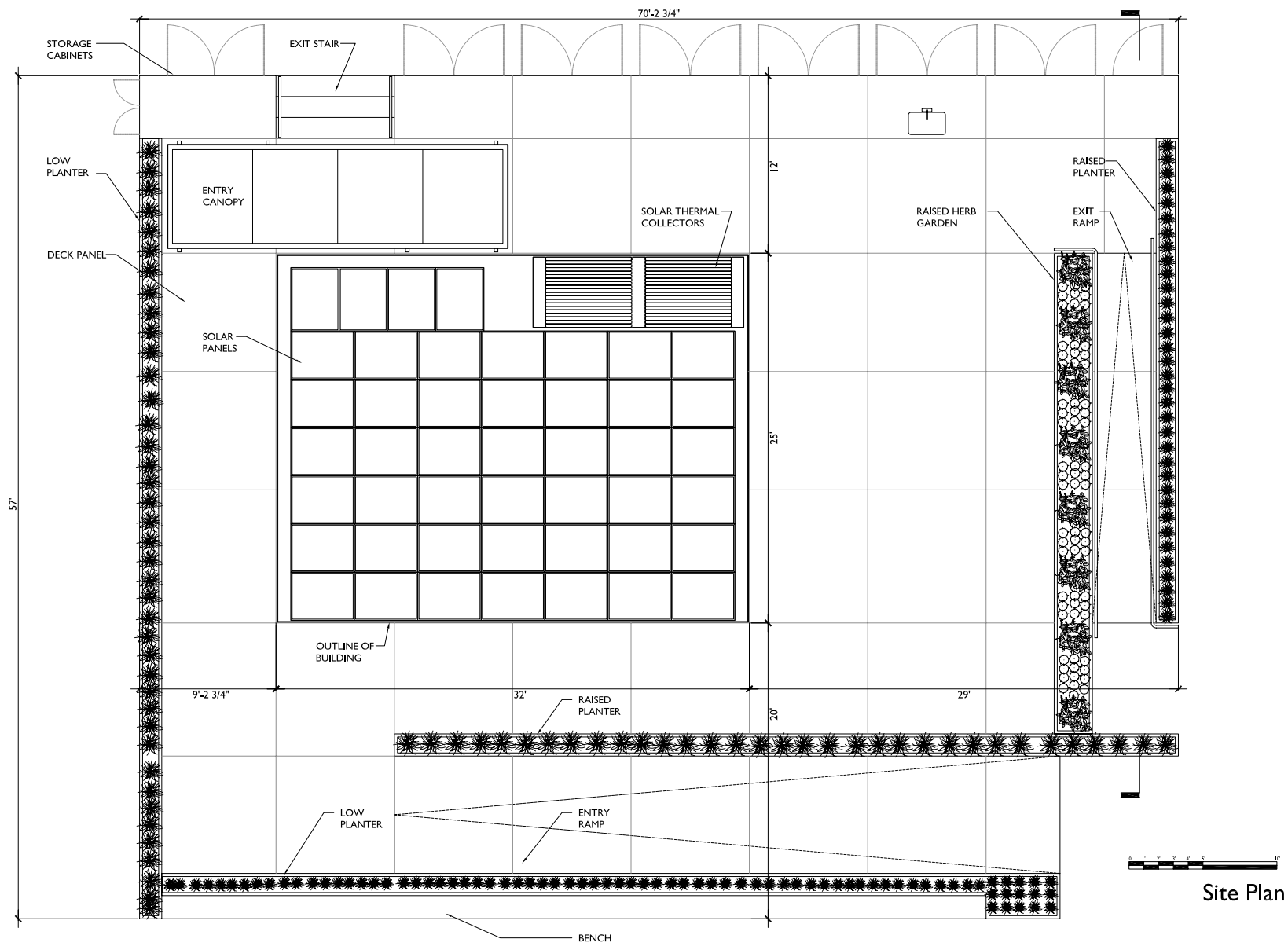
Day 4. 48Mc-S Photovoltaic modules. http://www.day4energy.com/downloads/Day4-48MCS_Specs-EN.pdf (accessed Feb. 6, 2010).

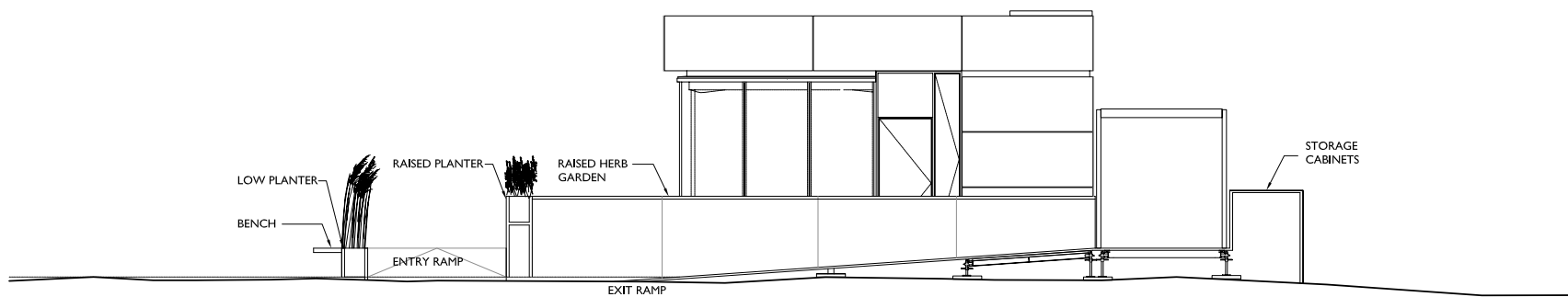
Decoustics. Madero / Quadrillo. <http://www.decoustics.ca/finishes/quadrillo/quadrillo-1.html> (accessed Feb. 6, 2010).

Demilec. Spray foam insulation. <http://www.demilec.com/demilec/dprode.html> (accessed Feb. 6, 2010).

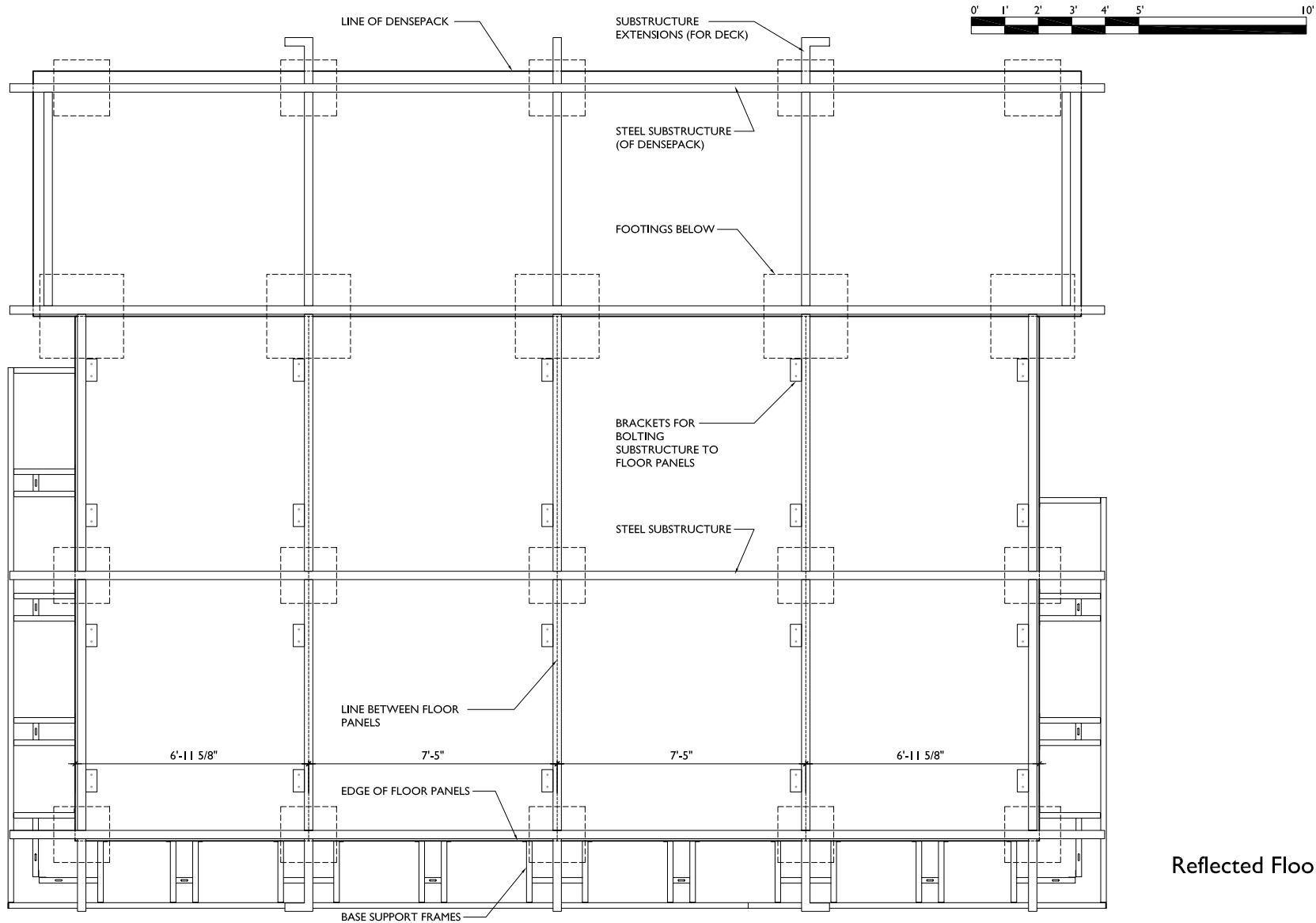
Draper Incorporated. Interior blinds. http://www.draperinc.net/Window_Shade_Pages/MotorizedFlexShade2.htm (accessed Feb. 6, 2010).

APPENDIX A - SELECTED AS-BUILT DRAWINGS

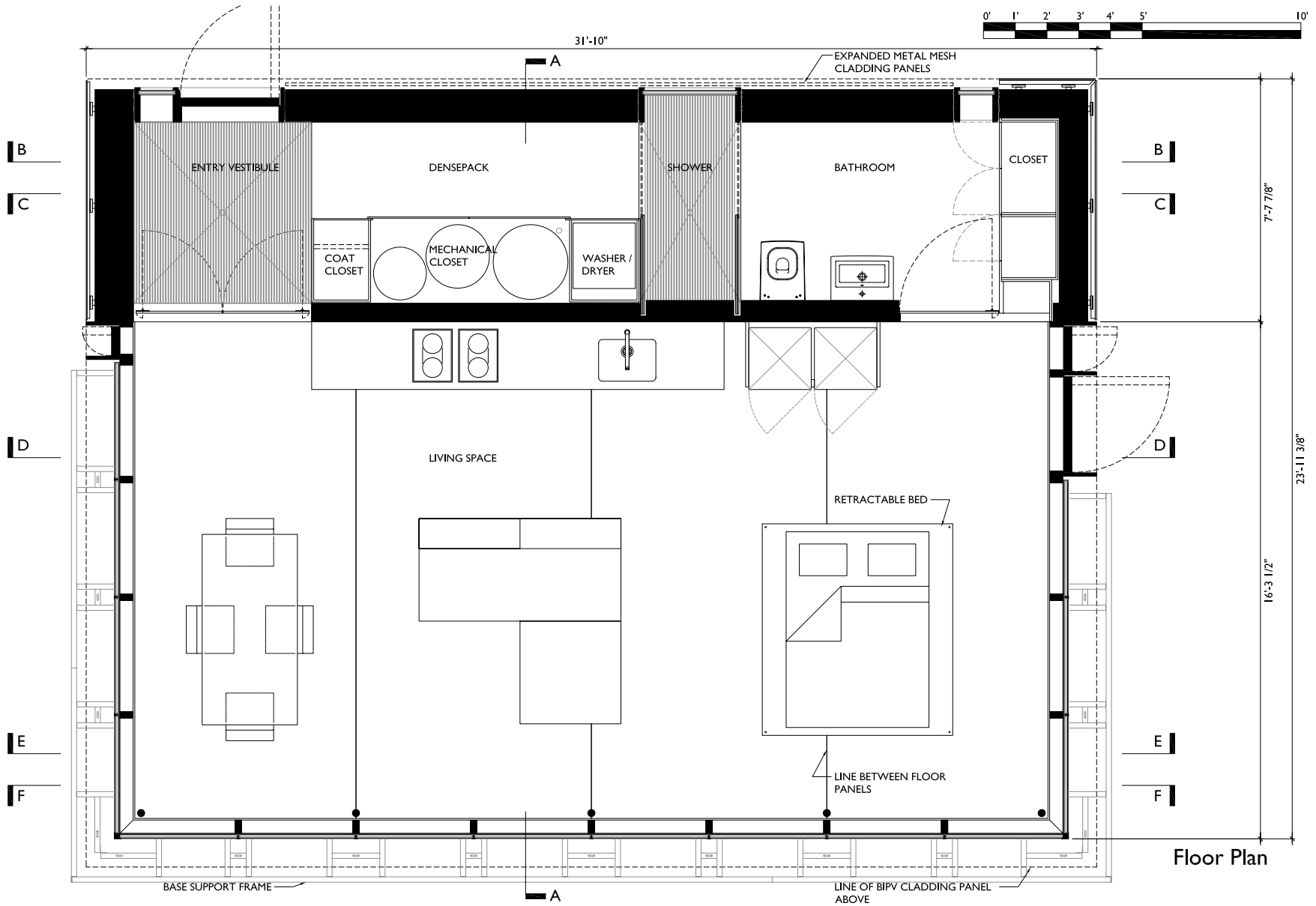




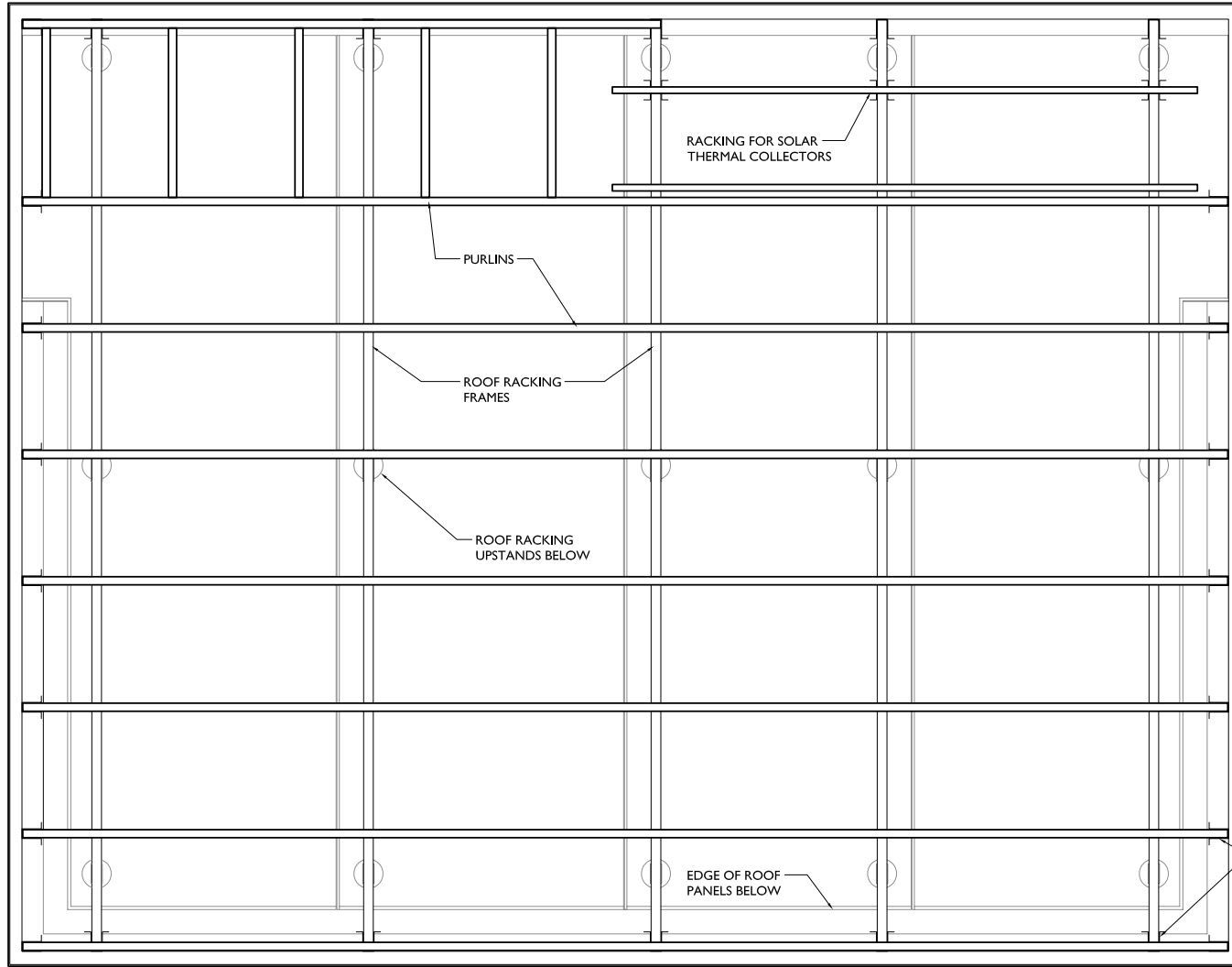
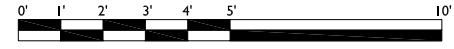
Site Section



Reflected Floor Plan



Floor Plan

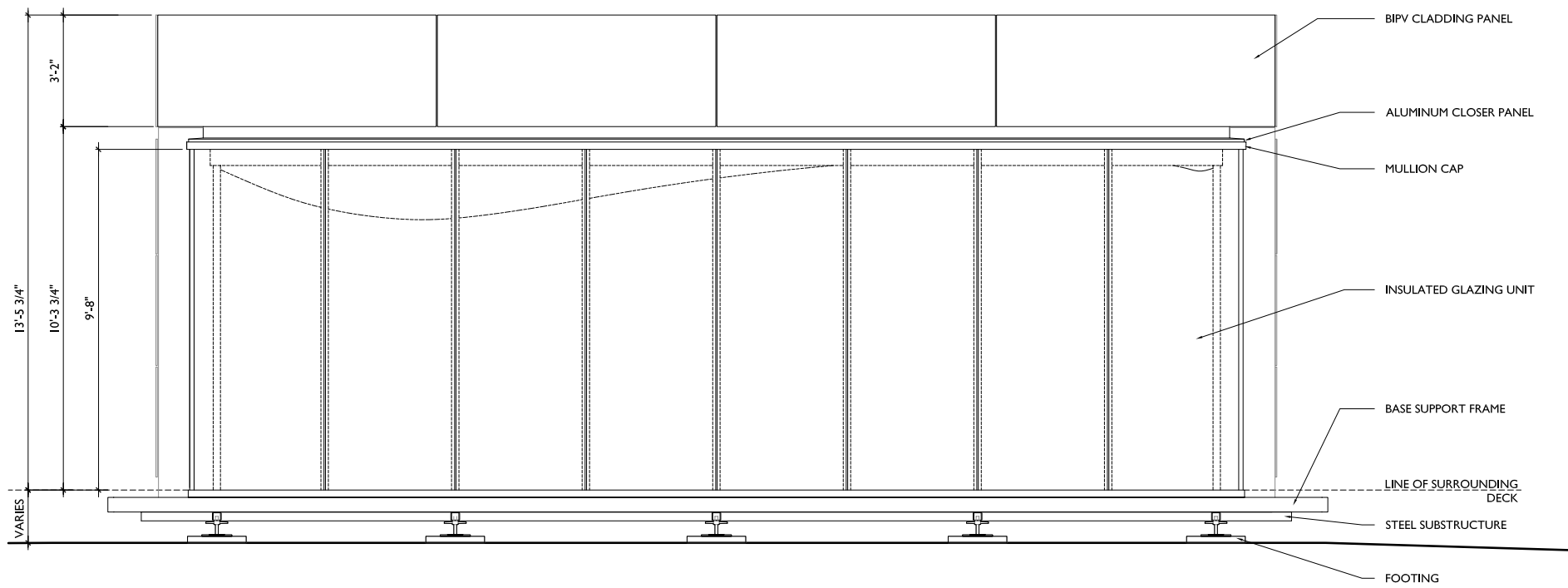


CLADDING SUPPORTS

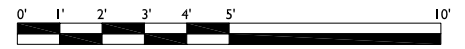
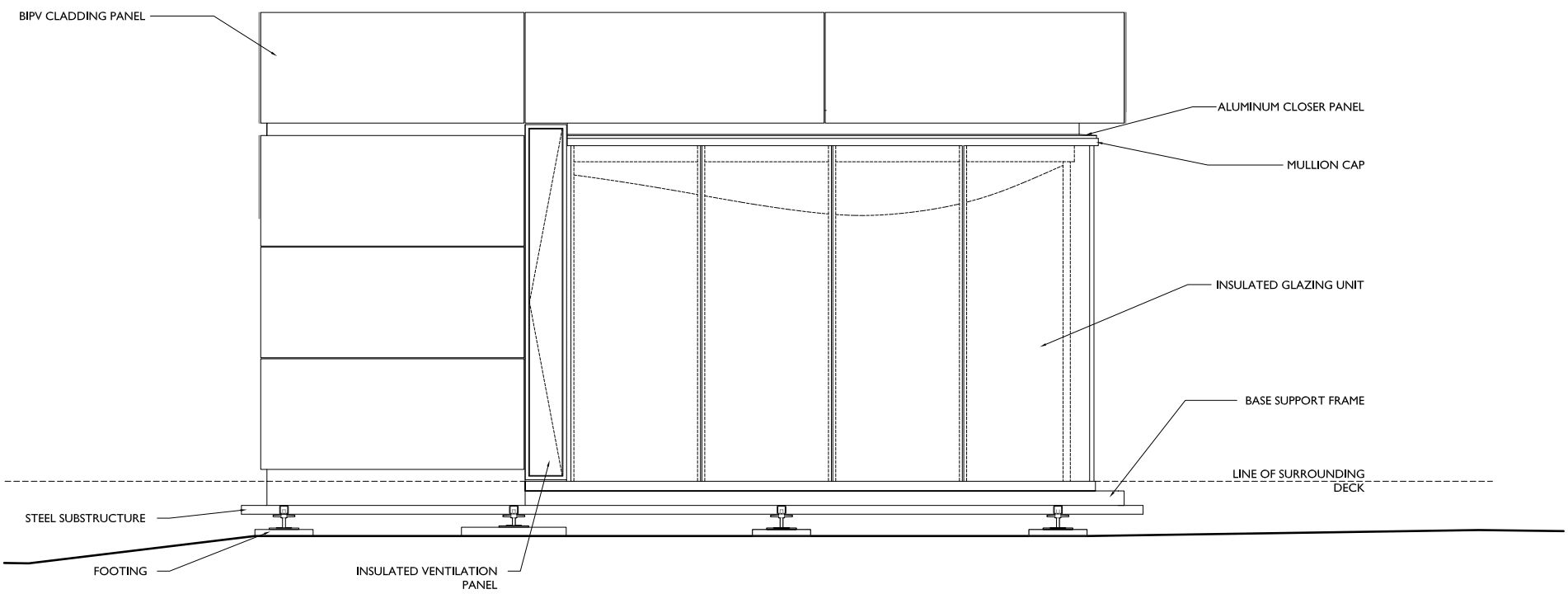
END BRACKETS (TO RECEIVE BIPV CLADDING AND EXTERIOR BLINDS) ON ROOF RACKING FRAMES AND PURLINS

Roof Racking Plan

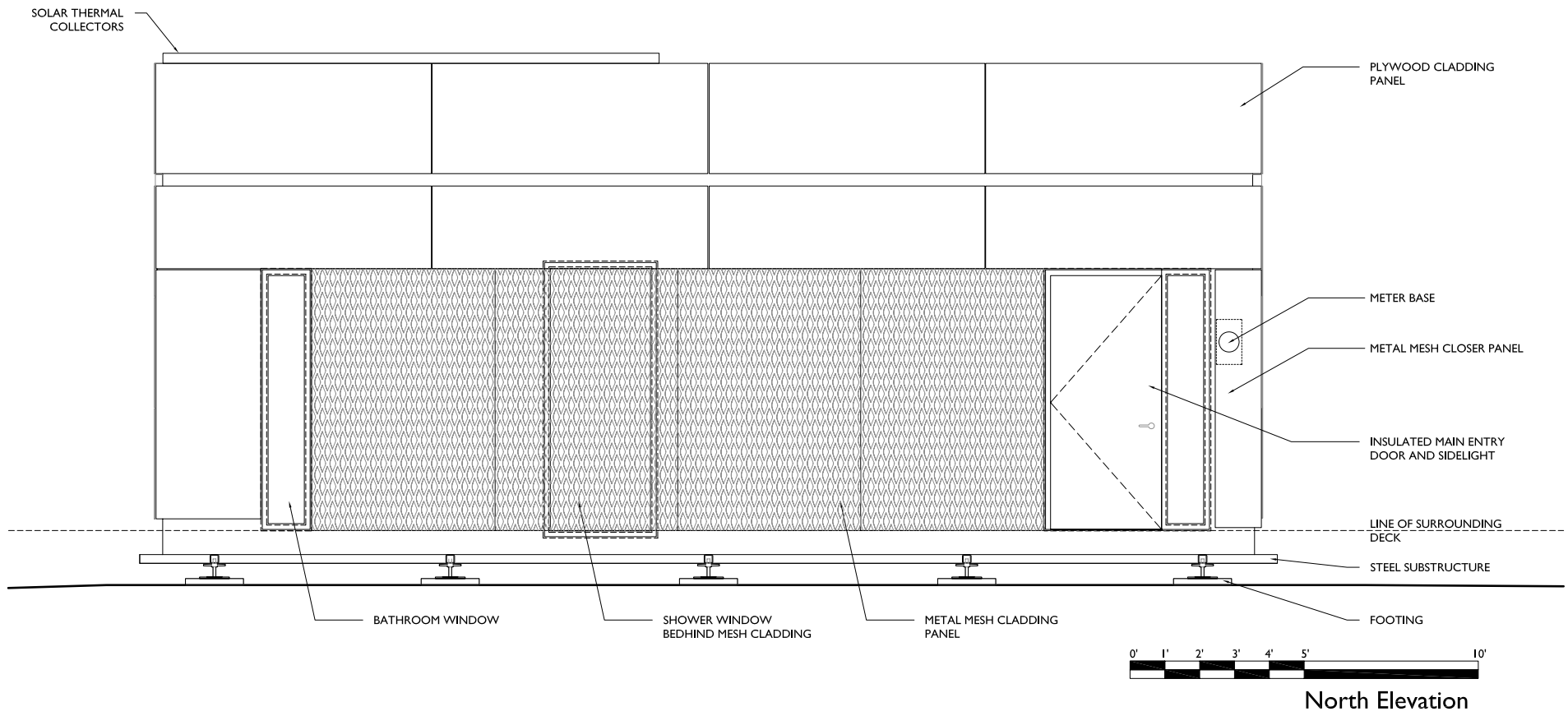
BIPV CLADDING PANELS

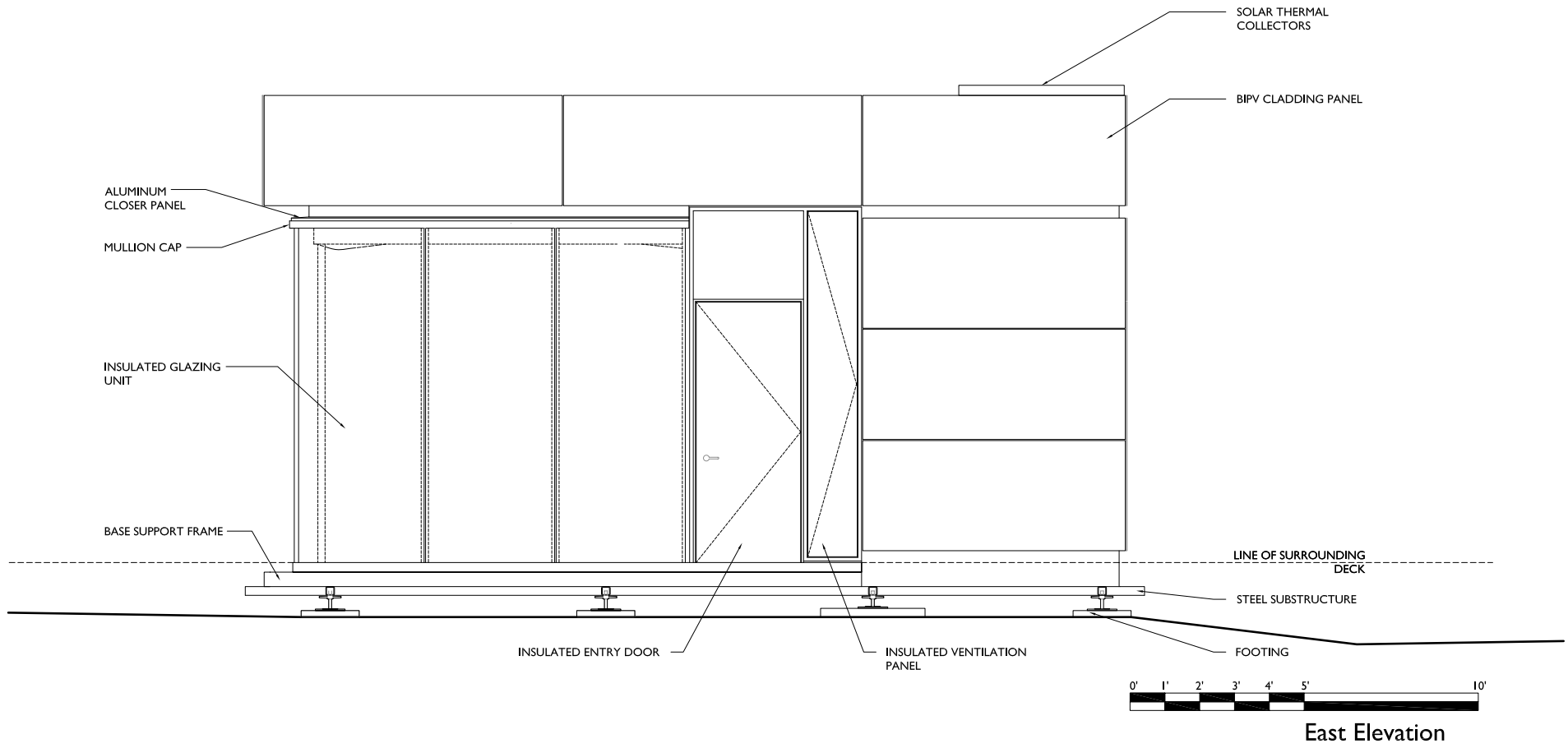


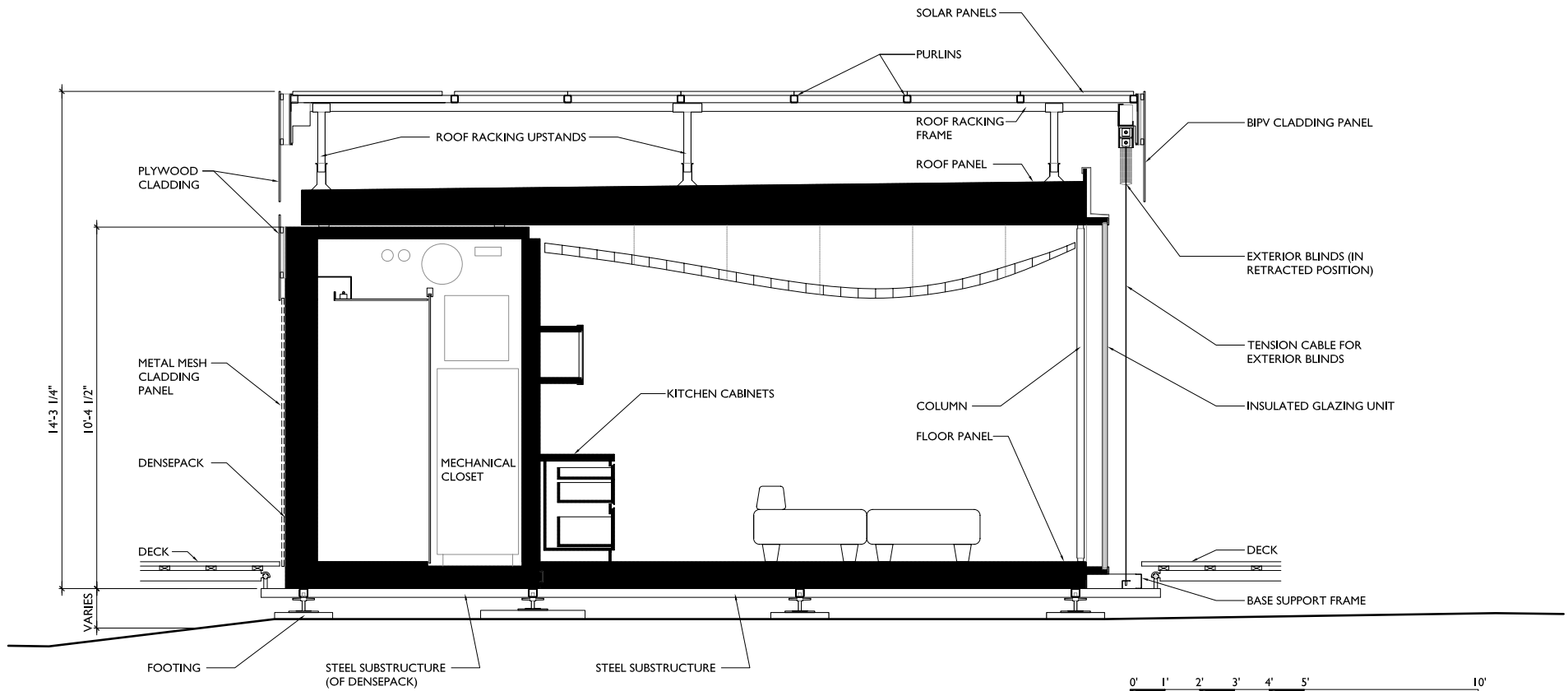
South Elevation



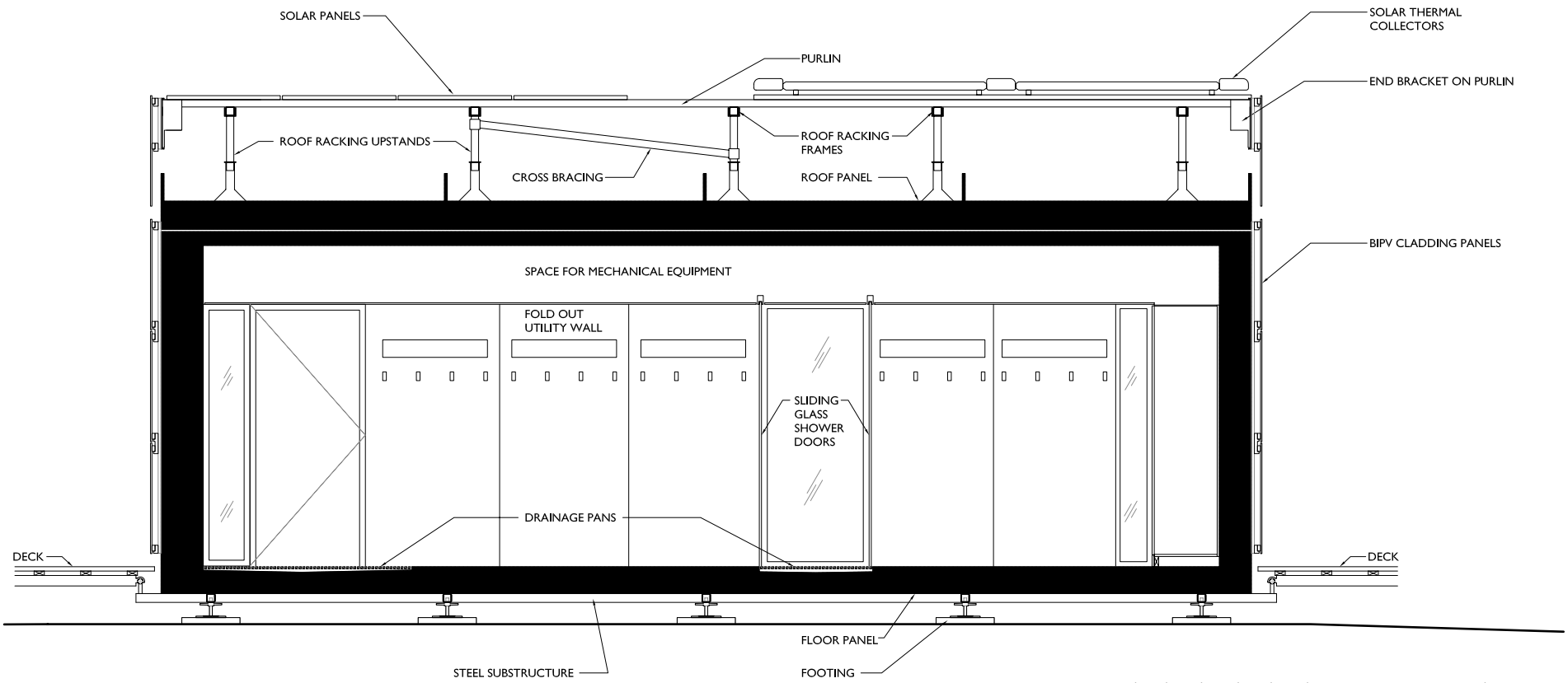
West Elevation



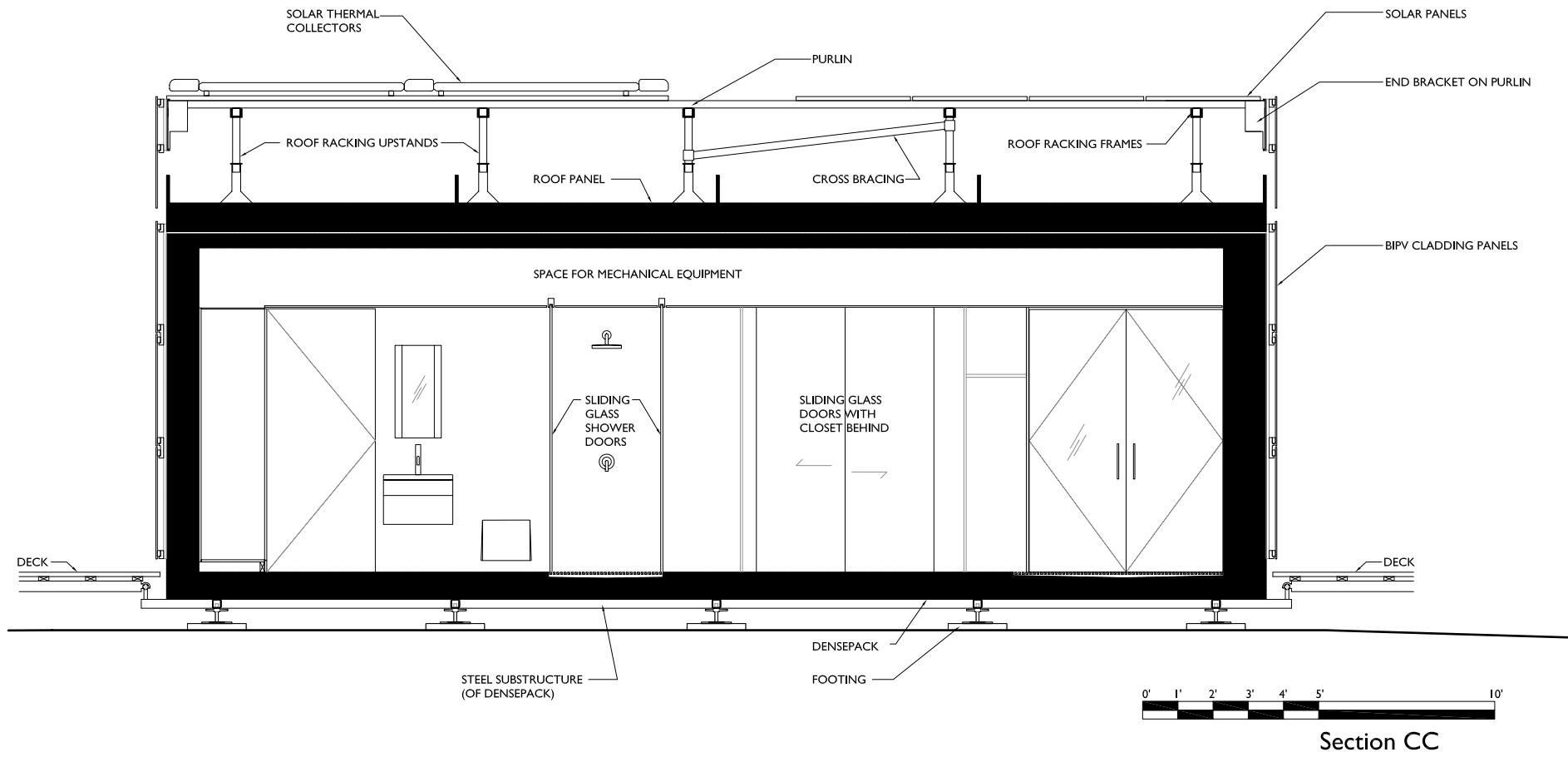


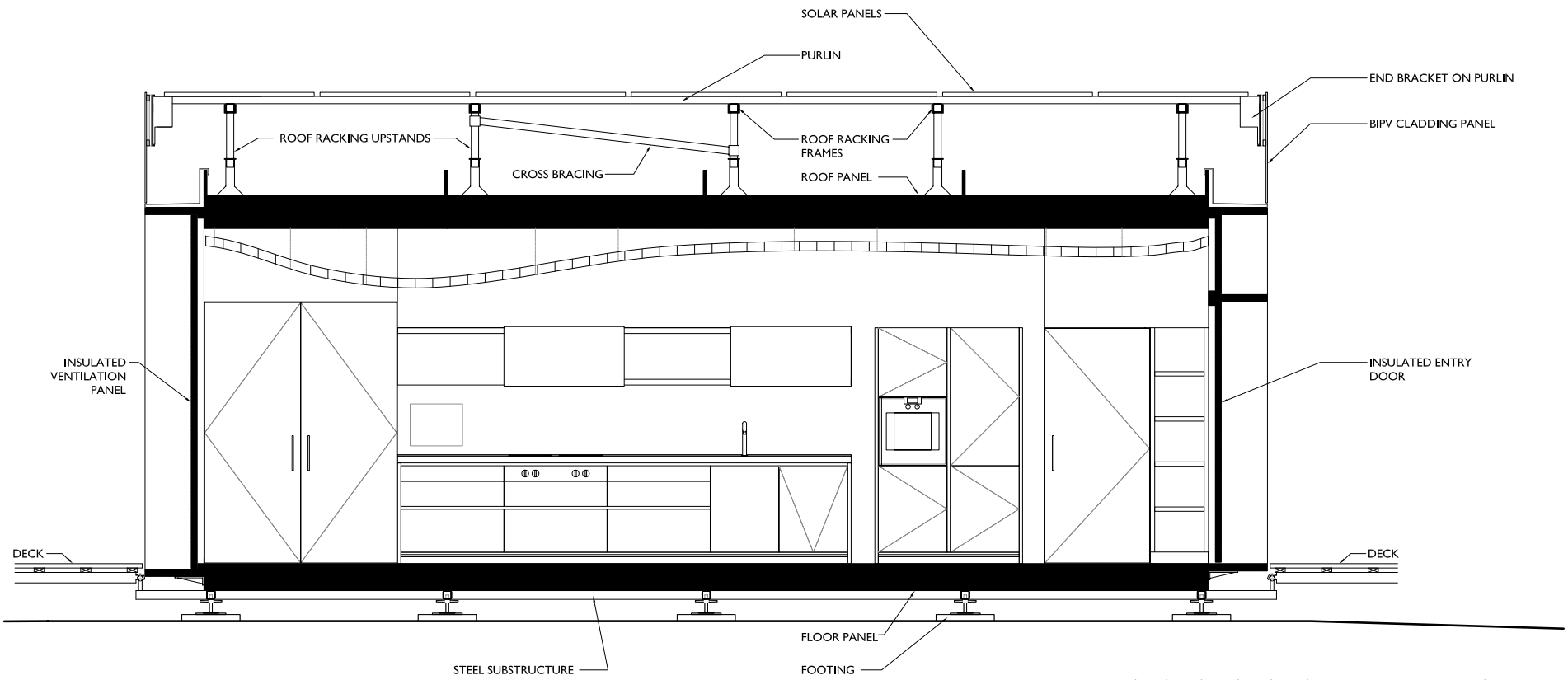


Section AA

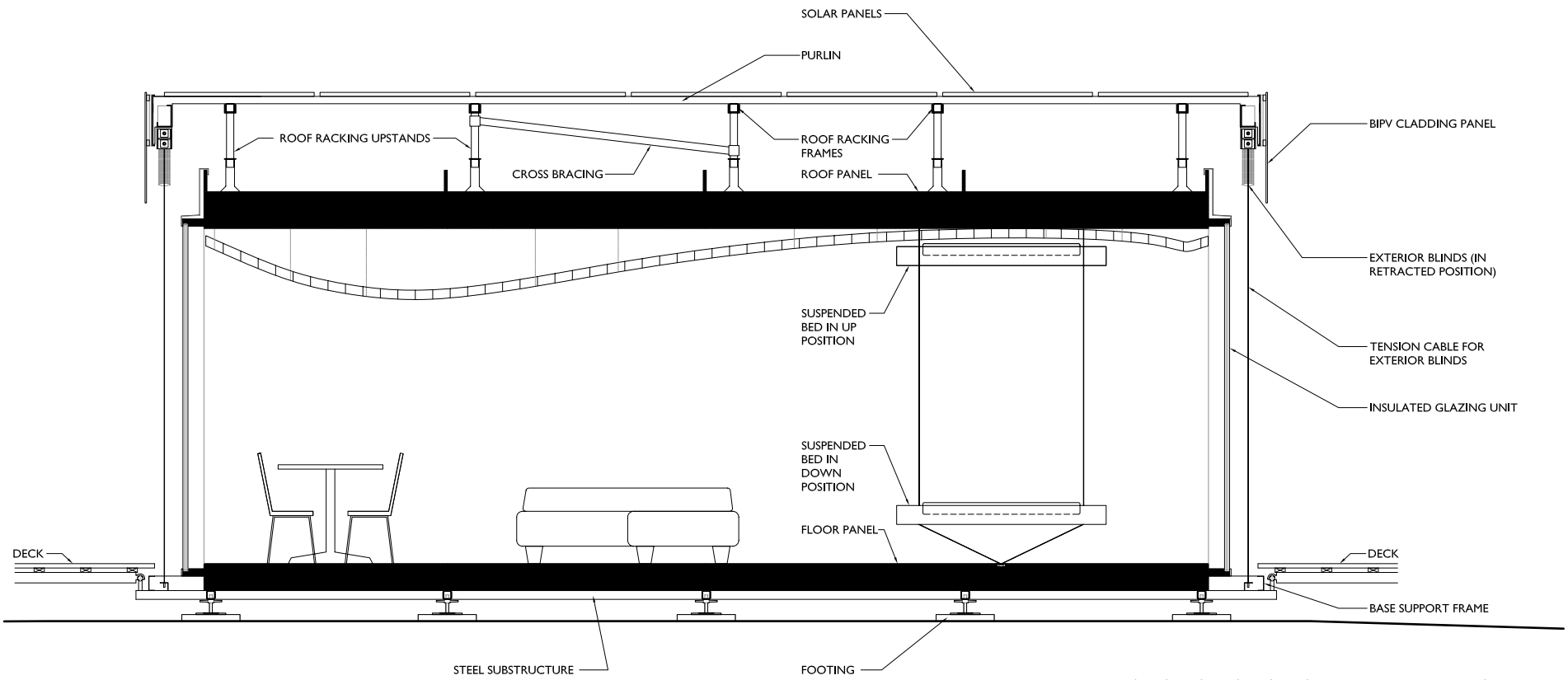


Section BB

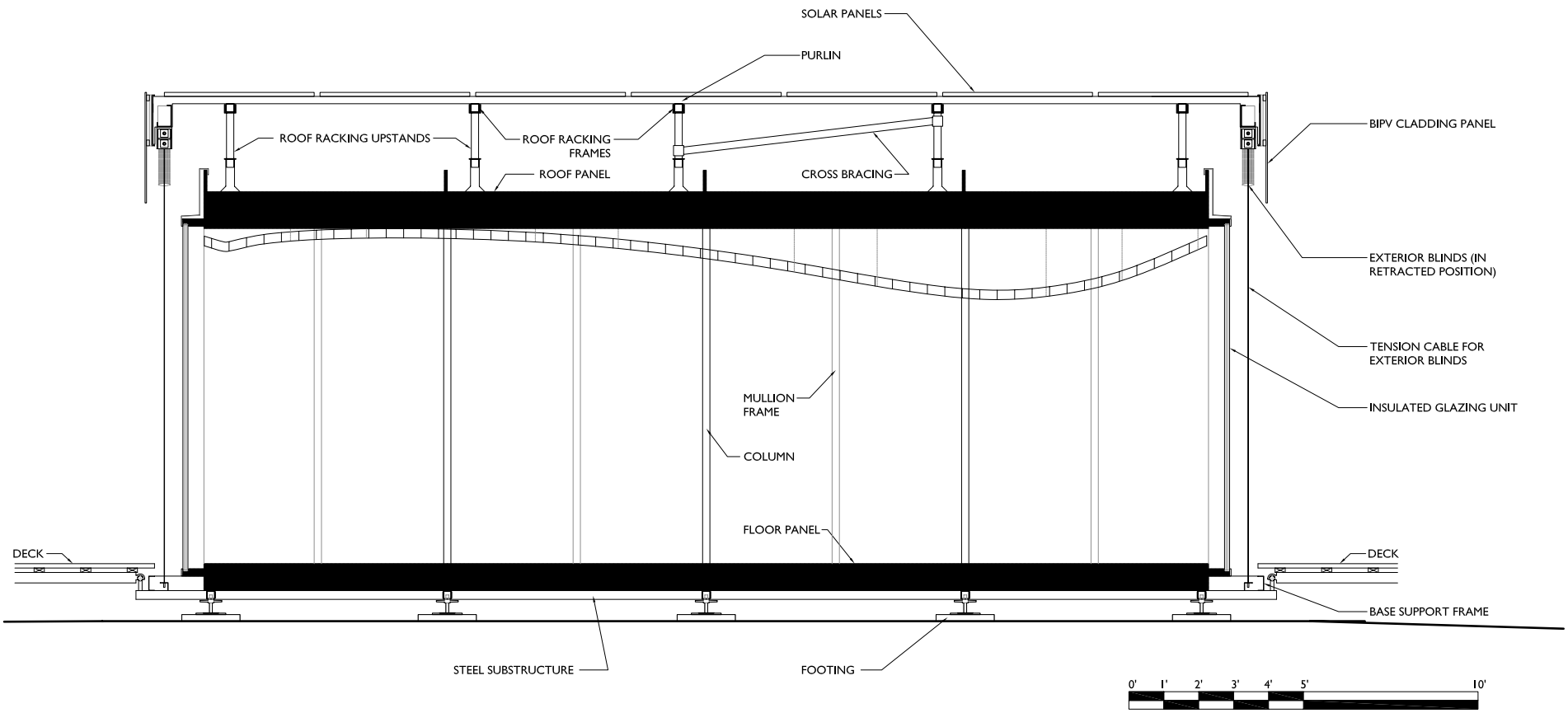




Section DD



Section EE



APPENDIX B - EXTENDED ACKNOWLEDGEMENTS

I would like to extend my thanks to all of the following people:

Faculty Team: Geoffrey Thün, Kathy Velikov, David Lieberman, Dr. John Straube, Philip Beesley, Donald McKay, Rick Haldenby & Dr. Michael Collins. (University of Waterloo)
Dr. Alan Fung (Ryerson University)
Dr. Lyn Bartram & Dr. Rob Woodbury (Simon Fraser University)

Core Architectural Student Team: Lauren Barhydt, Chris Black, Maun Demchenko, Natalie Jackson, Jen Janzen & Bradley Paddock.

Core Engineering Student Team: Sebastien Brideau, Brent Crowhurst, Ivan Lee, Bart Lomanowski, Andrew Marston, Toktam Saied & Humphrey Tse.

Interaction Design Student Team: Rob Mackenzie, Kevin Muise & Johnny Rodgers.

Additional Student Team: Fabio Almeida, Wade Brown, Eric Bury, Aya Dembo, Brittany Hanam, Andrew Haydon, Andrea Hunniford, Davis Marques, Lindsey Nette, Matt Peddie, David Schellingerhoudt, Sonja Storey-Fleming, Jamie Usas & Allan Wilson.

MCM 2001 Inc. Fabrication Team: Jack Debski, Gregory Rybak, Sean Baldwin, Witek Jasinski, Mikola Minzak, Krzysztof Banasek, Piotr Dabrowski, Zbigniew Gembora, Adam Golaszewski, Ryszard Goryl, Wladyslaw Iwaniec, Oleg Izvekoy, Philip Lesniak, Maks Matuszewski, Pawel Noga, Richard Pelly, Danny Pietrangelo, Krzysztof Plaza, Jan Sawczak, Luke Statkiewicz & Lukasz Szczepanek.

Structural Engineer: Cory Zurell

Red Electric Team: Dan Pelkman, Robin Sanders & Nicolas Stroeder.

Mechanical Team: Al Davies (Eco-Options Geosolar), Steve Davies (Ecologix Heating Technologies), Aaron Goldwater (Goldwater Solar Services) & Gord Walsh (Status Air).

Controls Design: Chris Brandson (Vertech Solutions) & Reid Blumell (Embedia Technologies)

Mackie Moving Systems: John Fyfe & Fred Taphouse.

Bulthaup Canada Kitchen Systems: Antje Bulthaup & Stefan Sybydlo.