

Doubling and Desire

by

Diana Zepf

A thesis
presented to the University of Waterloo
in fulfilment of the
thesis requirement for the degree of
Master of Architecture

Waterloo, Ontario, Canada, 2010

© Diana Zepf 2010

Author's Declaration

I hereby declare that I am the sole author of this thesis. This is a true copy of the thesis, including any required final revisions, as accepted by my examiners.

I understand that my thesis may be made electronically available to the public.

Abstract

This thesis proposes that an investigation into the phenomenon of doubling may engage architecture with a type of desire that has deep rooted connections with the complexities of human nature, with the very human condition of desiring to know who/what/where/when/how we are. It proposes that an experience of doubling is suggestive of a specific kind of affective space that tests this relationship, expanding into the interval we have formed between our body, its being and space. The proposal is to explore the material, spatial, and psychological characteristics of such a phenomenon - to understand the virtual space created through this doubling and its architectonic characteristics.

The design ambition of this thesis is to construct an architectural fiction that engages with this doubling. If architecture has the capacity to embody the ambitions and anxieties of society, the work produced attempts to invoke, through choreographed doublings manifested by the movement of figure and light through constructions in time, that human condition of desire that is concerned with finding/defining itself in the unknown - not to provide an answer for what the unknown is, but to engage with its enigmatic nature. By engaging in the protean dynamics of doubling and desire, this thesis attempts to poeticize the interval between the body and its built environment.

Acknowledgements

Supervisor

Dereck Revington

Committee

Anne Bordeleau

John McMinn

External

Yvonne Lammerich

THANK YOU

To all involved. This was a process and journey that became richer with your input and support.

Table of Contents

iii	Author's Declaration
v	Abstract
vii	Acknowledgements
ix	Table of Contents
xi	List of Illustrations
p1	Prologue : A Duet of Shade and Light
p7	Introduction
p11	Chapter 1 Doubling and Desire
p12	Introduction: Eros, the River of Desire
14	Ted Hughes: Desire Arising
20	Narcissus: The Emergence of Doubling
24	Woodman & Artaud: Doubling between Figure and Ground
36	Conclusion
p41	Chapter 2 Types of Doubling
p42	Introduction
44	Ontological Doubling
48	Oneiric Doubling
54	Phenomenological Doubling
60	Conclusion: Doubling, a Portal Metaphor
p63	Chapter 3 Doubling and Design
p64	Design Intent
70	Cycle 1: Reflection
94	Cycle 2: Shadow
122	Cycle 3: Iridescence
p147	Epilogue : Drawing Conclusions
p153	References
p159	Appendix: Experiencing the Work

List of Illustrations

f.001 pxviii by Author 'Doubling : Utterance and Audition'

PROLOGUE: A Duet of Shade and Light

f.002 p2-3 by Author 'Tone of the Void : Film Stills'

f.003 p4-5 by Author 'Tone of the Void : Graphic Film Narrative'

INTRODUCTION

f.004 p7 by Author 'Doubling : Utterance and Audition'

CHAPTER ONE: Doubling and Desire

f.005 p12-13 by Author 'River of Desire : Film Stills'

f.006 p14 David Spriggs 'Force'
(www.davidspriggs.com)

f.007 p15 by Author 'River / Desire : Photo 1'

f.008 p15 by Author 'River / Desire : Photo 2'

f.009 p16 David Spriggs 'Emergence of Perception'
(www.davidspriggs.com)

f.010 p17 by Author 'River / Desire : Photo 3'

f.011 p17 by Author 'River / Desire : Photo 4'

f.012 p18 David Spriggs 'Emergence of Perception' - detail
(www.davidspriggs.com)

f.013 p19 by Author 'River / Desire : Photo 5'

f.014 p19 by Author 'River / Desire : Photo 6'

f.015 p20 Carravaggio 'Narcissus'
(www.lightandmatter.com/html_books/5op/ch02/ch02.html)

f.016 p21 by Author 'Withheld : Photo 1'

f.017 p22 Ernst Mach 'Inner Perspective'
(www.payer.de/fremd/mach.htm)

LIST OF ILLUSTRATIONS

f.018	p23	David Spriggs	'Manifold' (www.davidspriggs.com)
f.019	p26	Antonin Artaud	'Portrait of Paule Thevenin or Paule with Irons' (Artaud & Rowell 1996, 115)
f.020	p26	Francesca Woodman	'From Angel Series, Italy, May 1977 - August 1978' (Sollers & Woodman 1998, 103)
f.021	p28	Francesca Woodman	'Providence, Rhode Island, 1976' (Sollers & Woodman 1998, 83)
022	p29	Francesca Woodman	'From Angel Series, Italy, May 1977 - August 1978' (Sollers & Woodman 1998, 103)
023	p30	Francesca Woodman	'Then at One Point, Providence, Rhode Island, 1976' (Sollers & Woodman 1998, 60)
024	p31	Francesca Woodman	'From Space ² , Providence, Rhode Island, 1975 - 1976' (Sollers & Woodman 1998, 61)
025	p32	Antonin Artaud	'Portrait of Paule Thevenin or Paule with Irons' (Artaud & Rowell 1996, 115)
026	p33	Antonin Artaud	'Self Portrait 11 May 1946' (Artaud & Rowell 1996, 86)
027	p34	Antonin Artaud	'Spell for Roger Blin' (Artaud & Rowell 1996, 48-49)
028	p34	Antonin Artaud	'The Theater of Cruelty' (Artaud & Rowell 1996, 79)
029	p35	Antonin Artaud	'The Projection of the True Body' (Artaud & Rowell 1996, 129)
030	p39	Francesca Woodman	'Providence, Rhode Island, 1975 - 1976' (Artaud & Rowell 1996, 54)
031	p39	by Author	'House of Doors'

CHAPTER TWO: Types of Doubling

032	p42-43	by Author	'Tone of the Void : Film Stills'
033	p44	Unknown Artist	'Allegory of the Cave' (http://img441.yfrog.com/i/allegoryofthecaveillusi.jpg/)
034	p45	Unknown Artist	'Untitled' (http://vilmamachado.typepad.com/blog_de/2009/03/index.html)
035	p46	Gustave Doré	'Conversion of Saul' (http://www.creationism.org/images/DoreBiblelllus/index.htm)

036	p46	Samuel van Hoogstraten	'The Shadow Dance' (Stoichita 1997, 130)
037	p48	Joseph-Benoit Suvée	'The Invention of the Art of Drawing' (Warner 2006, 158)
038	p49	Paul Nadar	'Daguerre (+ Honoré de Bazac') (www.artnet.com/artist/584572/paul-nadar.html)
039	p50	Sir John Tenniel	'Alice Pushes through the Mirror' (www.fromoldbooks.org/LewisCaroll-AliceThroughTheLookingGlass/)
040	p51	Juliet Quintero	'Alice's House : Axonometric' (www.aas.bartlett.ucl.ac.uk/architecture/programmes/units/unit12_04.htm)
041	p52	Anish Kapoor	'Ishi's Light' (Kapoor & Baume 2008, 106)
042	p53	Anish Kapoor	'S-Curve' (Kapoor & Baume 2008, 27)
043	p54	Oskar Schlemmer	'Egocentric Space Lines' (Schlemmer & Maur 1972, 44)
044	p55	Norman McLaren	'Pas de Deux' - film still detail (http://fifid.com/subject/2839965/)
045	p56	Thanos Vovolis	'Masks for Aeschylus' - detail (www.didaskalia.net/issues/vol7no1/vovolis_zamboulakis.html)
046	p57	Francesca Woodman	'Self-Portrait Talking to Vince' (Sollers & Woodman 1998, 50)
047	p58	Margaret Watts-Hughes	'Daisy Form' (Watts-Hughes 1914, 38)
048	p60	Francesca Woodman	'Study for Space ² , Providence, Rhode Island, 1975 - 1978' (Sollers & Woodman 1998, endpapers)

CHAPTER THREE: Doubling and Design

DESIGN INTENT

049	p64	by Author using John Gibson's	'Eos Collage' 'Sculpture of Aurora' (http://homepage.mac.com/cparada/GML/Eos.html)
050	p65	by Author	'Stills Diagram'
051	p66	by Author	'Cycle Diagram'
052	p67	by Author	'Projection Diagram'

LIST OF ILLUSTRATIONS

CYCLE 1 : REFLECTION

053	p70	by Author	'Cycle 1 : Doubling at Dusk, Portal 1'
054	p71	by Author	'Cycle 1 : Doubling at Dusk, Portal 2'
055	p72	by Author	'Spatial Arrangement of Video Projection'
056	p72-73	by Author	'Cycle 1 : Film Narrative in Stills'
057	p74-5	by Author	'Cycle 1 : Doubling, Dawn Sequence'
058	p77	by Author	'Cycle 1 : Doubling, Detail'
059	p78-9	by Author	'Cycle 1 : Doubling, Dusk Sequence'
060	p80	Francesca Woodman	'A Woman A Mirror A Woman is a Mirror for a Man' (Sollers & Woodman 1998, 71)
061	p80	Francesca Woodman	'A Woman A Mirror A Woman is a Mirror for a Man' (Sollers & Woodman 1998, 71)
062	p81	Francesca Woodman	'From Space ² , Providence, Rhode Island, 1975 - 1976' (Sollers & Woodman 1998, 73)
063	p81	Francesca Woodman	'From Space ² , Providence, Rhode Island, 1975 - 1976' (Sollers & Woodman 1998, 72)
064	p82	by Author	'Withheld : Photo 01'
065	p83	by Author	'Withheld : Photo Composition'
066	p84	by Author	'Cycle 1 : Material, One-way Glass'
067	p85	by Author	'Cycle 1 : Model Construction'
068	p86	by Author	'Cycle 1 : Pinhole Camera'
069	p87	by Author	'Cycle 1 : Pinhole Photos, different light exposures in Portal 1'
070	p87	by Author	'Cycle 1 : Pinhole Photos, different light exposures in Portal 2'
071	p87	by Author	'Cycle 1 : Key Pairing of Stills'
072	p88-89	by Author	'Cycle 1 : Diagram of Light in Time through Construction'
073	p88-89	by Author	'Cycle 1 : Film Narrative in Stills'
074	p90	Georges Lakhovsky	'Formation of Primordial Cells' (Lakhovsky 1951, 161)
075	p91	by Author	'Cycle 1 : Drawing, Construction in Time'
076	p92	by Author	'Cycle 1 : Drawing, Doubling at Dawn'

077	p93	by Author	'Cycle 1 : Drawing, Doubling at Noon'
078	p93	by Author	'Cycle 1 : Drawing, Doubling at Dusk'
CYCLE 2 : SHADOW			
079	p94	by Author	'Cycle 2 : Doubling at Dusk, Passage 1'
080	p95	by Author	'Cycle 2 : Doubling at Dusk, Passage 2'
081	p97	by Author	'Spatial Arrangement of Video Projection'
082	p96-97	by Author	'Cycle 2 : Film Narrative in Stills'
063	p98-99	by Author	'Cycle 2 : Doubling at Dawn'
064	p101	by Author	'Cycle 2 : Doubling, Detail'
065	p102-3	by Author	'Cycle 2 : Doubling at Dusk'
086	p104	Francesca Woodman	'It Must Be Time For Lunch Now, New York, 1979' (Sollers & Woodman 1998, 119)
087	p104	Francesca Woodman	'From Angel Series, Italy, May 1977 - August 1978' (Sollers & Woodman 1998, 103)
088	p105	Francesca Woodman	'Providence, Rhode Island, 1976' (Sollers & Woodman 1998, 83)
089	p105	Francesca Woodman	'New York, 1979' (Sollers & Woodman 1998, 126)
090	p106	by Author	'Through & Through 1 : Film Still'
091	p106	Lisa Robinson	'Departed' (www.lisamrobinson.com/new_index.php)
092	p107	by Author	'Through & Through 1 : Video in Stills'
093	p108	by Author	'Through & Through 2 : Photo 01'
094	p109	by Author	'Through & Through 2 : Model Photos'
095	p110	by Author	'Cycle 2 : Material, Translucent Stretch Textile'
096	p111	by Author	'Cycle 2 : Model Construction'
097	p112	by Author	'Cycle 2 : Test Photos of Internal Lighting'
098	p113	by Author	'Cycle 2 : Test Photos, Passage 1 light advancing'
099	p113	by Author	'Cycle 2 : Test Photos, Passage 2 light receding'
100	p113	by Author	'Cycle 2 : Key Pairing of Stills'

LIST OF ILLUSTRATIONS

101	p114	by Author	'Cycle 2 : Photo Array, Passage 1'
102	p115	by Author	'Cycle 2 : Selected Sequence, light & figure advancing, Passage 1'
103	p116-7	by Author	'Cycle 2 : Diagram of Light through Construction'
104	p116-7	by Author	'Cycle 2 : Film Narrative in Stills'
105	p118	Leonardo da Vinci	'Study of Shadow Projection' (Stoichita 1997, 63)
106	p119	by Author	'Cycle 2 : Construction in Time'
107	p120	by Author	'Cycle 2 : Doubling at Dawn and Dusk (Day 1)'
108	p121	by Author	'Cycle 2 : Doubling at Dawn and Dusk (Day 2)'

CYCLE 3: IRIDESCENCE

109	p122	by Author	'Cycle 3 : Doubling at Dawn, Cusp 1'
110	p123	by Author	'Cycle 3 : Doubling at Dusk, Cusp 2'
112	p125	by Author	'Spatial Arrangement of Video Projection'
112	p124-5	by Author	'Cycle 3 : Film Narrative in Stills'
113	p126-7	by Author	'Cycle 3 : Doubling, Dawn Sequence'
114	p128-9	by Author	'Cycle 3 : Doubling, Detail'
115	p130-1	by Author	'Cycle 3 : Doubling, Dusk Sequence'
116	p132	Francesca Woodman	'Some Disordered Interior Geometries' - detail (www.web.ncf.ca/ek867/2009_04_01-15_archives.html)
117	p132	Francesca Woodman	'Self Portrait Talking to Vince' (Sollers & Woodman 1998, 50)
118	p133	Francesca Woodman	'Roma, May 1977 - August 1978' (Sollers & Woodman 1998, 111)
119	p133	Francesca Woodman	'On Being an Angel, Providence Rhode Island, 1977' (www.heenan.net/woodman/providence/rhode-island-27.shtml)
120	p134	by Author	'Colour of Breath : Collage'
121	p134	by Author	'Colour of Breath : Vocal Reaffirmation'
122	p135	by Author	'Colour of Breath : Colour Change in Time'
123	p136	by Author	'Cycle 3 : Material, Equilateral Acrylic Prism'
124	p137	by Author	'Cycle 3 : Model Construction'

125	p138	by Author	'Cycle 3 : Test Photo of Internal Lighting'
126	p139	by Author	'Cycle 3 : Test Photos, seperating light through Cusp 1'
127	p139	by Author	'Cycle 3 : Test Photos, white light through Cusp 2'
128	p139	by Author	'Cycle 3 : Test Photos, exhalation across surface of Cusp 2'
129	p140-1	by Author	'Cycle 2 : Rhythm of Breath as a Notation'
130	p140-1	by Author	'Cycle 2 : Film Narrative in Stills'
131	p142	Unknown Author	'Prism Experiments' (www.gutenberg-e.org/lowengard/C_Chap01.html)
132	p143	by Author	'Cycle 3 : Construction in Time'
133	p144	by Author	'Cycle 3 : Doubling at Dawn'
134	p145	by Author	'Cycle 3 : Doubling at Dusk'

EPILOGUE: Drawing Conclusions

135	p150	Francesca Woodman	'Roma, May 1977-August 1978' (Sollers & Woodman 1998, 107)
136	p151	Francesca Woodman	'Roma, May 1977-August 1978' (Sollers & Woodman 1998, 106)

APPENDIX: Experiencing the Work

137	p159	by Author	'Exhibition - Entrance off Main Street'
138	p160	by Author	'Exhibition - Set-up Diagram'
139	p161	by Author	'Exhibition - Entrance Space 1'
140	p161	by Author	'Exhibition - Entrance Space 1'
141	p162	by Author	'Exhibition - Screening Space, Right Video Screen 1'
142	p162	by Author	'Exhibition - Screening Space, Right Video Screen 2'
143	p163	by Author	'Exhibition - Screening Space, Select Shots of Stills on Light Panels'
144	p163	by Author	'Exhibition - Screening Space, Left Video Screen'

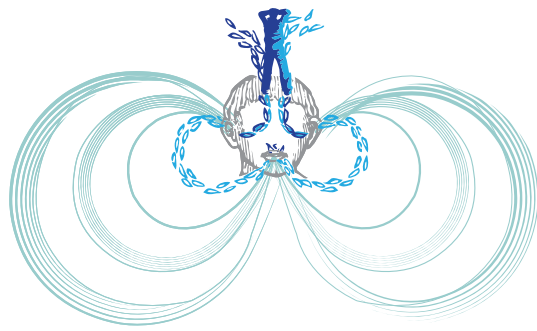

f.001

by Author 'Doubling: Utterance and Audition'

PROLOGUE:

Duet

A DUET OF SHADE AND LIGHT

Two girls there are : within the house
One sits; the other, without.
Daylong a duet of shade and light
Plays between these.

- *Sylvia Plath* from "Two Sisters of Persephone"
(Plath 1981, 31)

f.002

(this page & opposite) by Author 'Tone of the Void : Film Stills'



RIGHT

“Are you twins?” We looked at each other and laughed. Four years separate my sister and I, which in your youth is significant; at that age you want to believe that you are original and try to differentiate yourself in many ways - having a twin implies that there is someone else more or less like you, that parts of you exist outside of yourself.

Over the years we have been asked this same question multiple times and as the questions began to build I started to ask myself: Why did people have to know if we were twins or not? Why was having a twin so remarkable? Through the lens of hindsight past experiences of doubling began to resurface and link together. At 14 I believed that I was having an embodied recollection of a past life. On several occasions, on the brink of sleep, I felt I had once been a man of generous proportions. I felt it in my body, the space around me would expand.

Then there was the house I grew up in. On climbing the stairs into the attic my sister and I had shared, the doubling of the whole arrangement was suddenly obvious - the attic is bifur-



LEFT

cated; two doors face each other, opening onto similar rooms housing genetically similar people. There was something about it that was haunting, that spoke directly to my curiosity surrounding that question that resonated with this space: “are you twins?”

Suddenly, I no longer focused on the bodies of my sister and I, but on the nebulous contact boundary between those seemingly mirrored spaces that grew us. Sometimes my light was on when hers was off (f.002). Sometimes the light or dark coincided. The light was how we knew the other was there. I am here, I am not, she is here, she is not - the varying light became the tone of our presences and absences. What followed this observation was a video work that, masquerading as a diptych, is spatially true to life (f.003). The rooms’ filling and emptying of light over time creates a rhythm of occupation that variously coincides and differs, beating out an anagram in Morse code.

These observations and video work are the catalyst to the trajectory of this thesis.

PROLOGUE: A DUET OF SHADE AND LIGHT

s p a c e s / d o u b l e d

.....

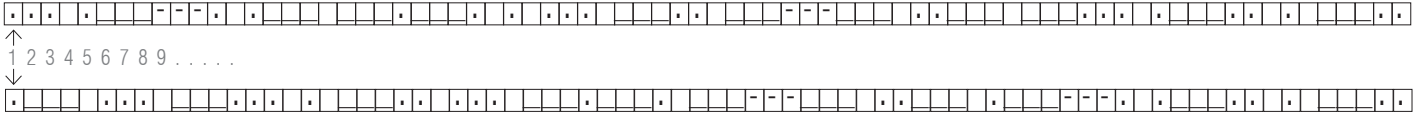

.....

a s / b e d s / c o u p l e d



TIME/ frames

1

2

3

←
etc...



f.003

by Author 'Tone of the Void : Graphic Film Narrative'



left



right



Title Tone of the Void
Date 13 March 2008
Size n/a
Technology video projection

Introduction

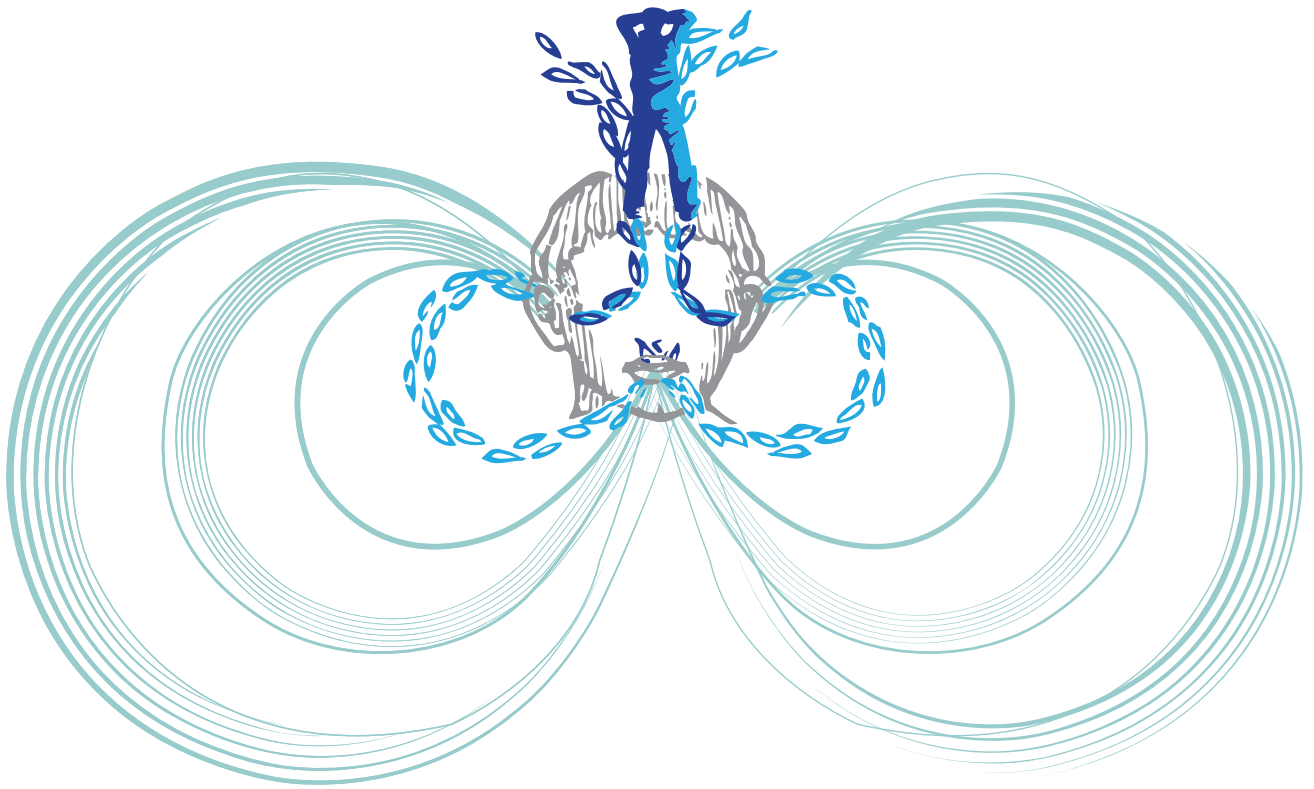

f.004

by Author 'Doubling: Utterance and Audition'

Introduction

This thesis seeks to enter into the desirous realm of doubling....

Chapter one begins with Anne Carson's' interpretation of Eros, the Greek god desire. Here the metaphor of water is used to move us through the dynamic relationship that begins to emerge between doubling and desire. Specifically, it is proposed that desire moves in protean transformations that are less concerned with the objects of desire than with a life driving force that is constantly pushing us to question the limits of the nature of our being. Doubling emerges as a phenomenon that shares in these protean tendencies, allowing for a brief and uncanny engagement with the dynamics of desire.

From beneath the surface of water where desire is described as arising in Ted Hughes' poem "Stump Pool in April," we emerge out of the river to look back upon it, where the myth of Narcissus introduces the phenomenon of doubling as a temptuous surfacing within its skin, a beckoning to merge with the depths desire occupies below. This then sets the tone for a reading into selected works by artists Francesca Woodman and Antonin Artaud that explicitly and materially engage the body of the subject within the work with a doubling that disturbs this proverbial skin of water. Proposing that this skin is a divide stretched between the body-as-flesh (figure) and its external environment (ground) their works are attempts at creating a portal through, to where an unmediated experience of being might be experienced. It is here that doubling is most cogently presented as a phenomenon that occurs along the rippling surface between what we understand as our body's limits and 'what else is out there.'

As doubling and desire seem to engage us with a line of questioning into the nature of our being and its relationship to its

milieu, chapter two then moves to examine the material and spatial properties of the phenomenon of doubling as it manifests itself in the interval between three binaries we have traditionally used to approach the definition of our being: the ontological (the doubling between body and universals), the oneiric (between body and dreams) and the phenomenological (between body and its sensed surroundings).

Informed by a richer understanding of these types of doublings, chapter three, the design portion of this thesis, takes the form of a series of constructed narratives in which three doublings - in reflection, shadow and iridescence - are choreographed and documented. These distil the ambition of the thesis as the construction of an architectural fiction of how one might engage the phenomenon of doubling as a material and spatial participant in generating atmospheres that key into this very protean condition of desiring.

Embedded within this thesis and its design explorations is an interest in atmosphere and force over a concern with form. Through its investigation into the philosophical, mythic and poetic associations with doubling and the provocative choreography of atmospheric events of doubling, it asks whether the consideration and incorporation of this phenomenon into the architect's design repertoire might embed within a project an enriched meaning within the user's experience of the work. As doubling is proposed to operate between our body and its milieu, the following chapters hope to illustrate the potentials that lie in the expanded interval that these experiences of doubling can open onto. Can experiences of doubling deepen the sense of mutual desiring that might be felt between and occupying body and its designed surroundings?

The undiscoverable house, where this lava flower
blows, where storms and exhausting bliss are
born, when will my search for it cease?

- *Gaston Bachelard* from *The Poetics of Space*
(Bachelard 1994, 51)

EROS: the River of Desire

As Alberto Perez-Gomez states in his book *Built upon Love*, “it is perhaps obvious that human desire has shaped the built environment” (Perez-Gomez 2006, 3) and yet he goes on to point out that once built, we find faults and build anew according to what we conceive of as new desires - we are continually transforming the built environment in an effort to keep pace with the driving force of desire that streams through us. He proposes that if desire is the protean force initiating our urge to continually create or build, a better understanding of these desires might inform a richer more meaningful architecture irrespective of the polarizing form vs. function approaches. His work is an exhaustive and thoroughly engaging investigation of Eros, the Greek god of desire and love and its connections to architecture.

Everything in existence has a beginning, with one exception: the beginning itself. ... In reality, the beginning is the one moment that you, as an unwitting target of winged Eros, cannot control. All that this moment brings, both good and evil, bitter and sweet, comes gratuitously and unpredictably.

- Anne Carson

(Carson 1986, 152)

Indeed Eros has been interpreted by Plato to Socrates, Sigmund Freud to Carl Jung and many others. As their interpretations of *what* Eros sets us to desiring varies: power, eroticism, self-knowledge, transcendence, happiness & desire for the other (Silverman 2000, 8), this thesis proposes a common thread - that Eros generates within us a longing for a profound sense of ‘completeness of being’ that might be had by engaging with what is other than or unknown to the desiring being. It is sympathetic with Anne Carson’s interpretation of Eros as *the beginning itself* in which “as you handle it you come into contact with what is inside you, in a sudden and startling way. You perceive what you are, what you lack, what you could be. ... A mood of knowledge floats out over your life. ... Something is lifting you towards an understanding so complete and clear it makes you jubilant” (Carson 1986, 152-153). This thesis does not aim to define what this ‘something’ is but rather understands the drive to engage with its enigmatic nature as the crucial life force that makes us human, that pushes us to define the nature of our

f.005

(opposite) by Author ‘River / Desire - Film Stills’

being both philosophically and creatively. Perhaps philosopher Joachim Gasquet was contemplating Eros' role in the human condition when he said, "the world is an immense Narcissus in the act of thinking about himself" (Bachelard 1983, 24).

If Eros is the river of desire that flows through all of us, when Anne Carson adds that a glance into Eros' depths (f.005) is a glance "down into time, at the realities you once knew," (Carson 1986, 153) she might as well be describing the first experience of the phenomenon of doubling. As *the* beginning Eros sets both desire and time in motion within us. When we look into Eros's depths a doubling manifests itself in which we perceive our current being along its surface superimposed over our past in its depths. This is a self-reflective doubling whereby we face the perpetual transformation of our being, where we are in brief contact with our desire as it moves out from under us.

This thesis is sympathetic with Alberto Perez-Gomez's imperative to re-engage architecture with a type of desire that has deep rooted connections with the complexities of human nature. However since desire is as protean as water through our fingers, this thesis hopes to engage with its enigmatic nature through the provocative phenomenon of doubling as Anne Carson starts to describe it, as a self-reflective experience that manifests between the desiring body and the protean unknown. The phenomenon of doubling has temporal and ephemeral qualities that have the capacity to engage one with an atmosphere in which the play of dynamic forces is emphasized over form, function or beauty. The next few pages start to describe the forces at work within desire itself before moving on to investigate the phenomenon of doubling as it engages with it in more detail.

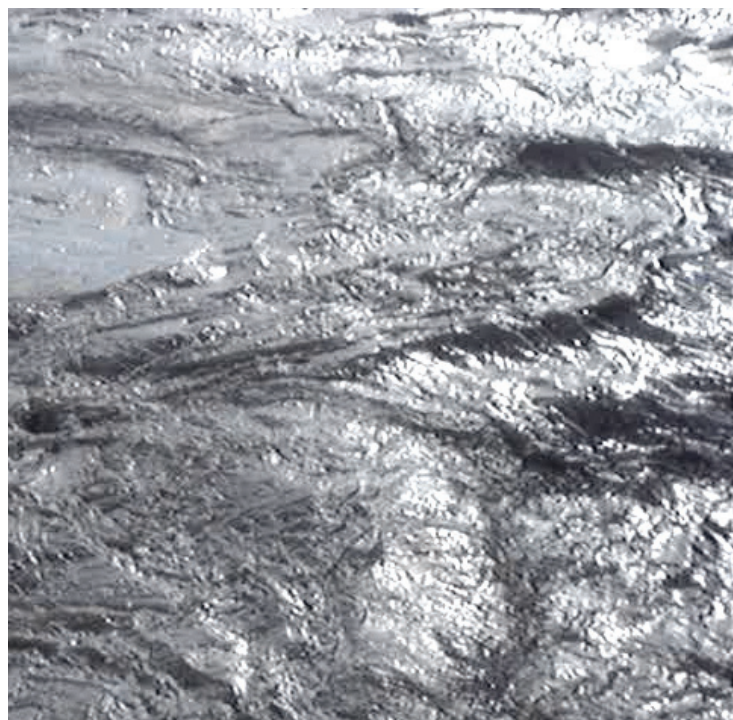
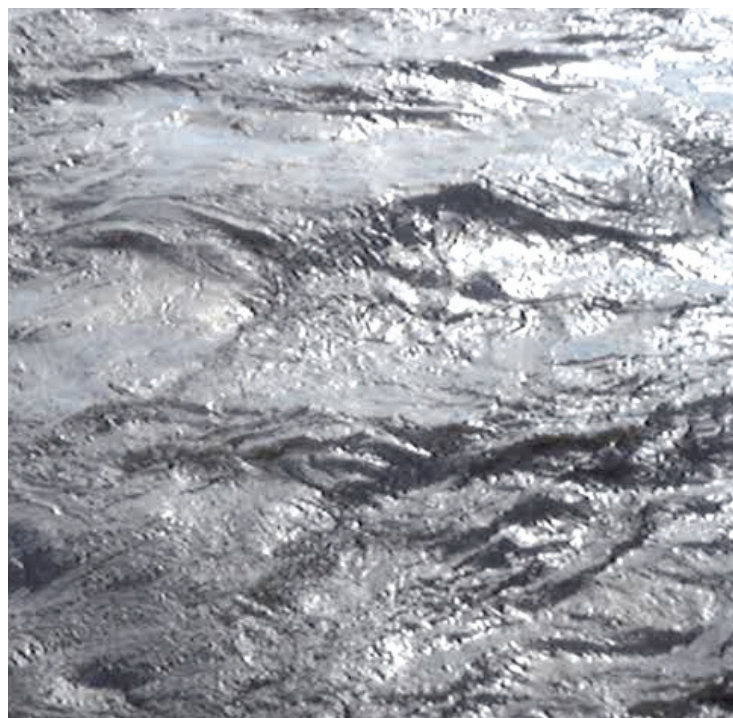
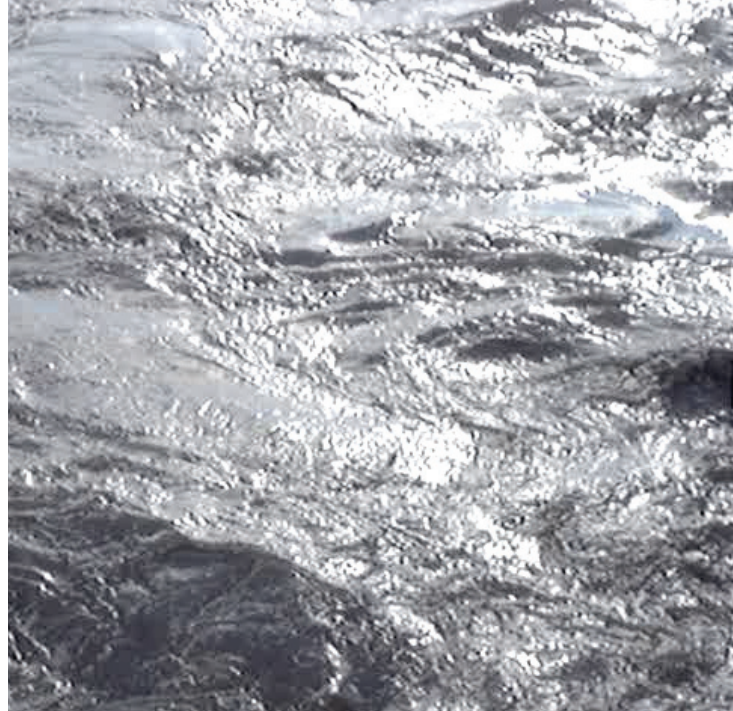

STUMP POOL IN APRIL

- *Ted Hughes* (Hughes 1984, 40)

Crack willows in their first pale eclosion
 Of emerald. The long pool
 Is simmering with oily lights. Deep labour
 Embodied under filmy spanglings. Oxygen
 Boils in its throat, and the new limbs
 Flex and loosen. It keeps
 Making the effort to burst its glistenings
 All down its living length.

The river is trying
 To rise out of the river.

April
 Has set its lights working. Its broad wings
 Creased and humped in their folds, convulse
 To lift out over the daffodils.

The soft strokings
 Of south wind keeps touching all its membranes
 Into spasming torments. It knows
 The time has come for it to alter
 And to fly, and somehow to tangle
 With the hill-wood - waiting high there, flushed
 In her bridal veil of haze violet.

f.006

David Spriggs 'Force'

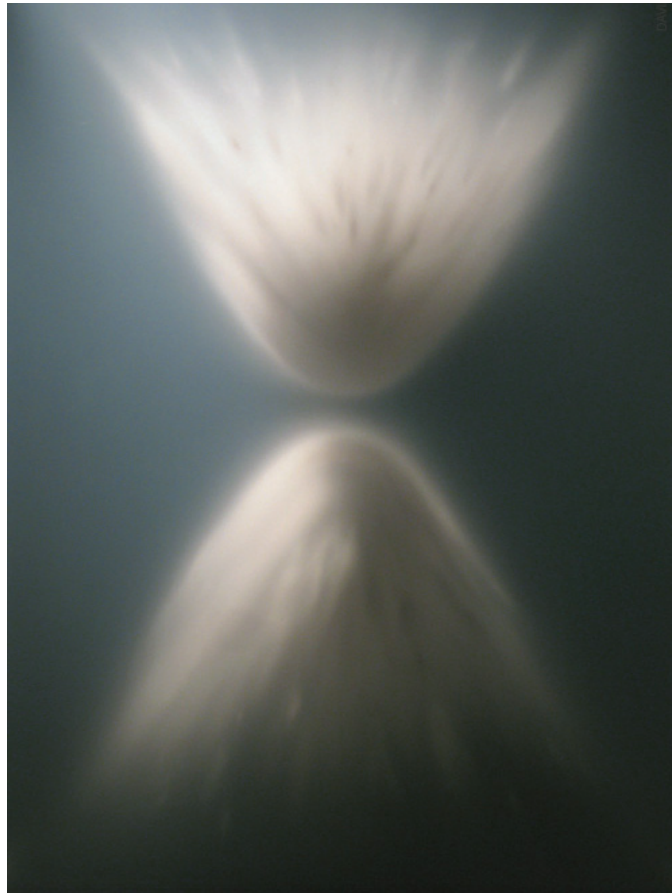

TED HUGHES: Desire Arising

How does desire affect the organism; how could one describe the dynamic forces that operate between them?

The two sensations are coupled together like 'wrestlers' and form a 'combat of energies,' even if it is a disembodied combat, from which is extracted an ineffable essence, a resonance, an epiphany erected within a closed world.

- *Gilles Deleuze*

(Deleuze and Bacon 2003, 57)

Ted Hughes' poem "Stump Pool in April" is an imagined account of desire arising in the body of water, of the material affect to the internals of its body the very moment, as Anne Carson [quoted p12] says, Eros hits its target - the moment it comes into contact with what it is and what it lacks. Hughes describes this moment as a first 'eclosion' or a hatching from an undeveloped state - the point at which water's body springs into metamorphosis. From this point forward the river flows, expanding and stretching to pull itself apart into glutinous layers, its subcutaneous body tangling in its own ropey extensions. As desire arises in the body, it couples with it "like 'wrestlers'" to "form a 'combat of energies'" that thickens and aerates (Deleuze and Bacon 2003, 57) causing the body to 'flex and loosen,' to 'alter.'

f.007

(opposite top) by Author 'River / Desire : Photo 1'

f.008

(opposite bottom) by Author 'River / Desire : Photo 2'

Wisp of Willow

coaxes swan song from flushing ghosts.

Heaving Breath - a lathered throat

stampeding,

herding dreaming currents

into easy elopement.

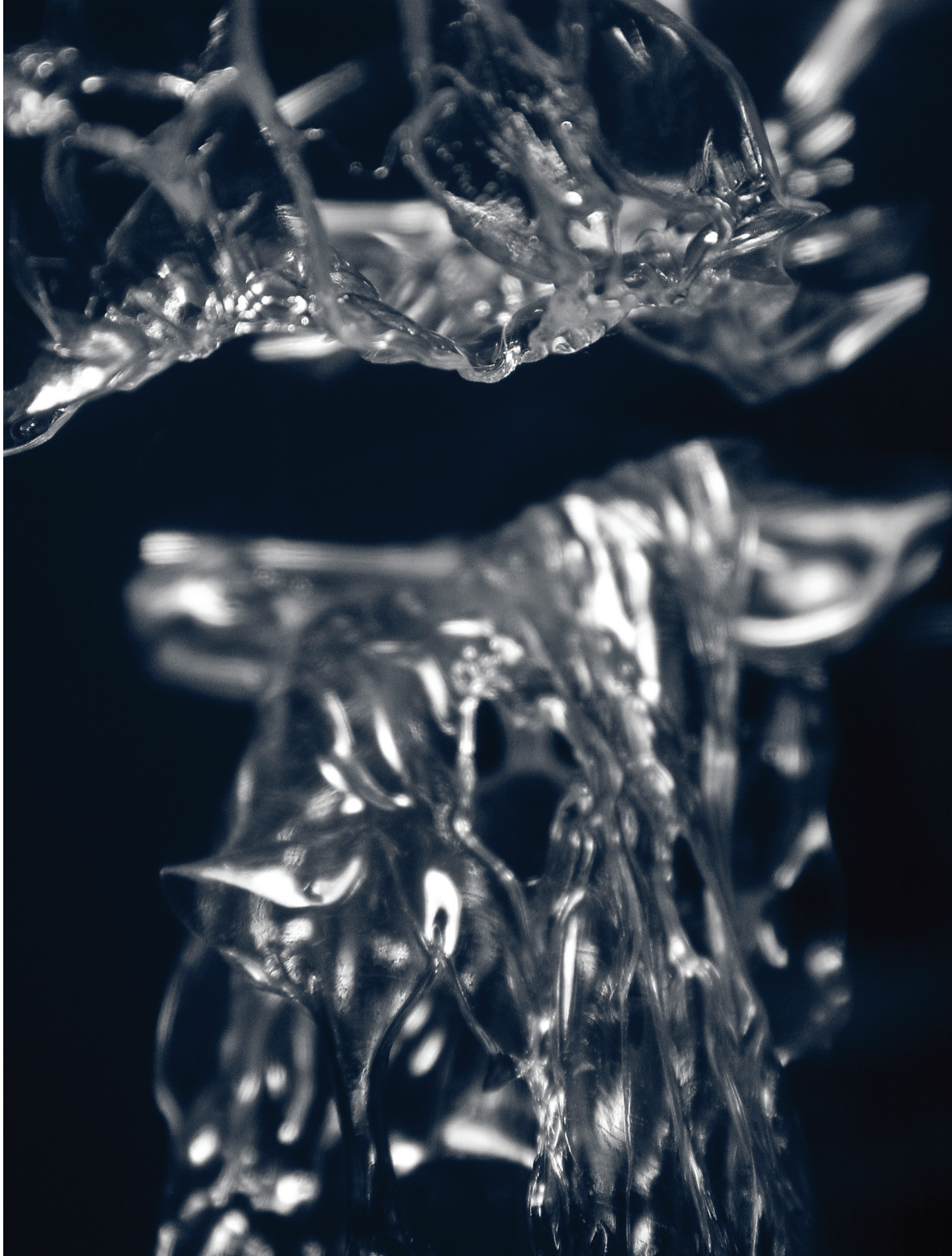

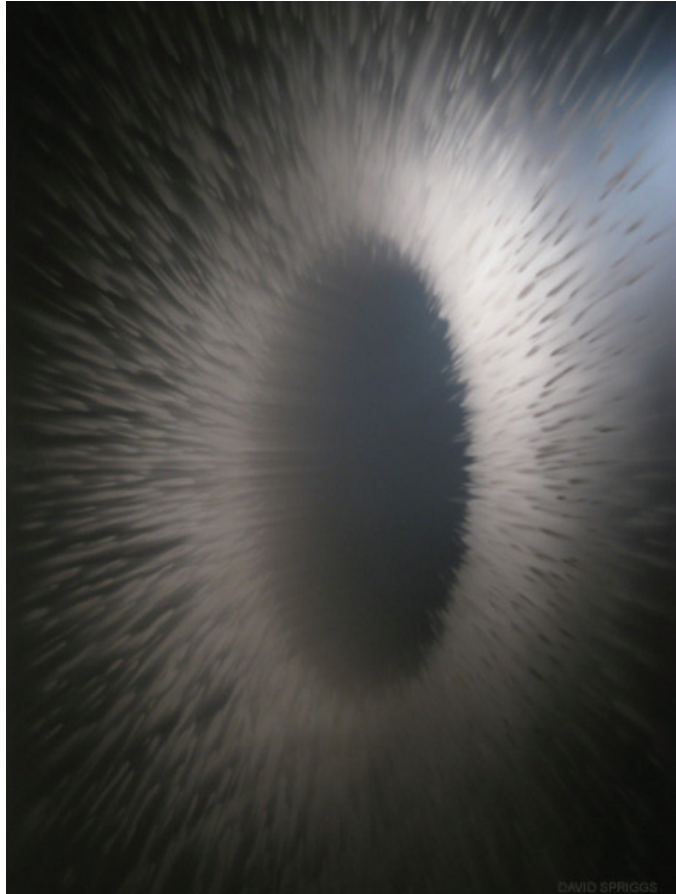

f.009

David Spriggs 'Emergence of Perception'

After a close reading of Ted Hughes' poem, this author attempted the translation of these forces into matter through a maquette and some writings (f.007-008, f.010-011, f.013-014). The works revolve around the phrases like "oxygen boils in its throat" and "burst its glistenings" as they resonate with forces of transformation.

The before or after of the transformation isn't the focus of the works, but rather the dynamics of the transformation itself – the effect it has on the body's material in its current happening. The gluey, headlong wantonness in the maquette is brought forth through an aerated melting of its matter in an attempt to invoke the river's 'deep labour' in transforming itself. Here the hot breath of air is the unseen force that desire's arising coaxes to boil and rip through the river's material, altering it through convulsing folds and expanding gaps.

f.010

(opposite top) by Author 'River / Desire : Photo 3'

f.011

(opposite bottom) by Author 'River / Desire : Photo 4'

Expectation enlongates.
Enchanted,
desire wriggles in pursuit -
rushing its pupation,
pushing and dragging rapids,
melting,
to possess one single thing.

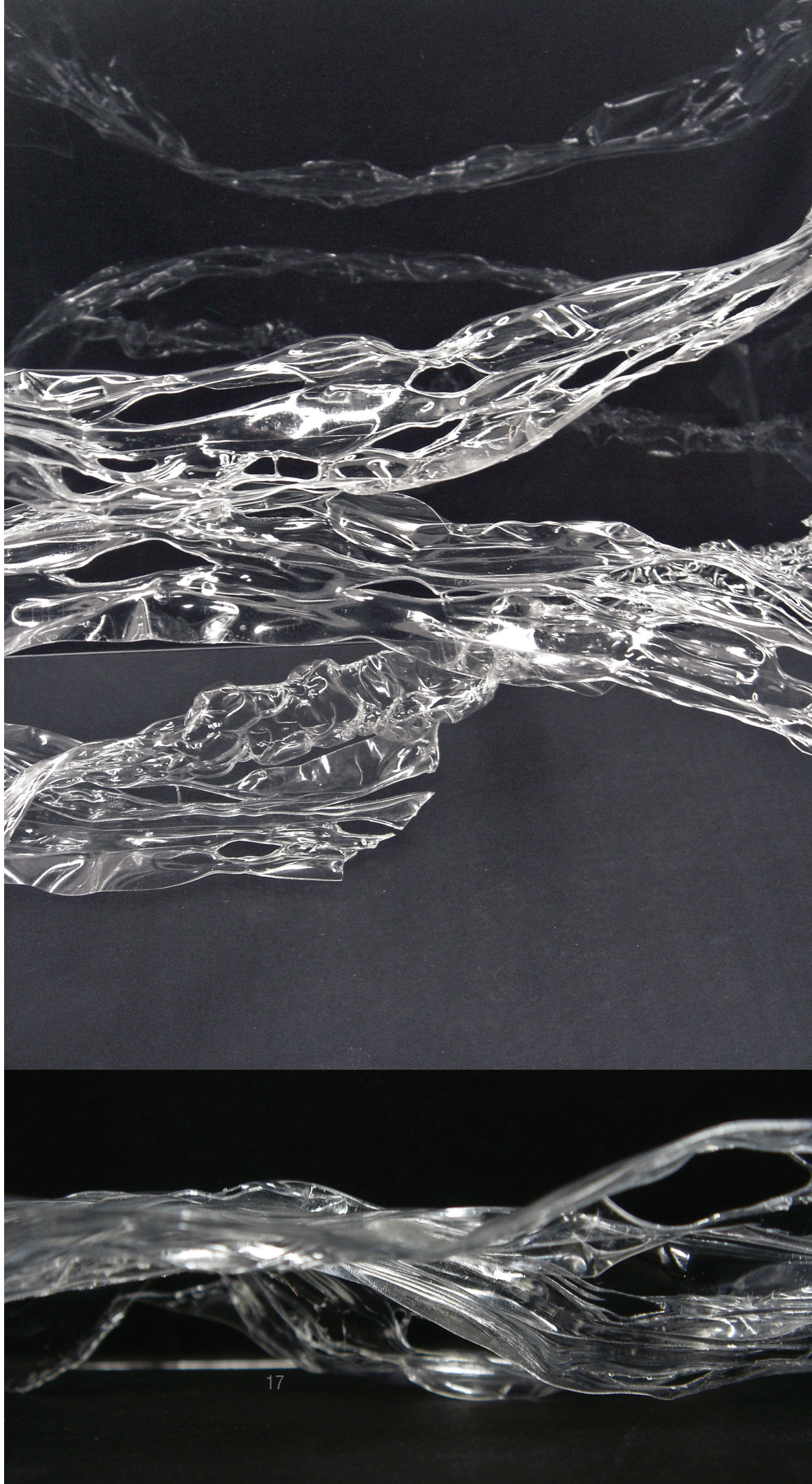



f.012

David Spriggs 'Emergence of Perception' - detail

David Spriggs' sculptures (f.006, f.009, f.012) seem to resonate with the transformative force that Ted Hughes sees as essentially linked to desire's arising within the body. Spriggs shoots light through spaced out transparent layers of paint sprayed plastic films (f.012). The subjects depicted in his sculptures are abstract forces that seem strikingly similar to nebulae and force of dynamite blasts. When viewed in person his statically rendered forces seem to be sucked up into the interval the work creates. For Spriggs, the skin of the films separating and agglutinating in the viewer's experience of the work becomes a portal to the elsewhere or 'other' that desire sets us moving towards; his works play at the mouth of the expanding gaps within the body that desire's arising within it initiates.

f.013

(opposite top) by Author 'River / Desire : Photo 5'

f.014

(opposite bottom) by Author 'River / Desire : Photo 6'

A desiring body is one that is in the midst of change.

A tiny vibration labours.
Travels fibrous lengths
to possess whiteness,
to expose its breadth -
flustered,
awash in all the colours of the world.

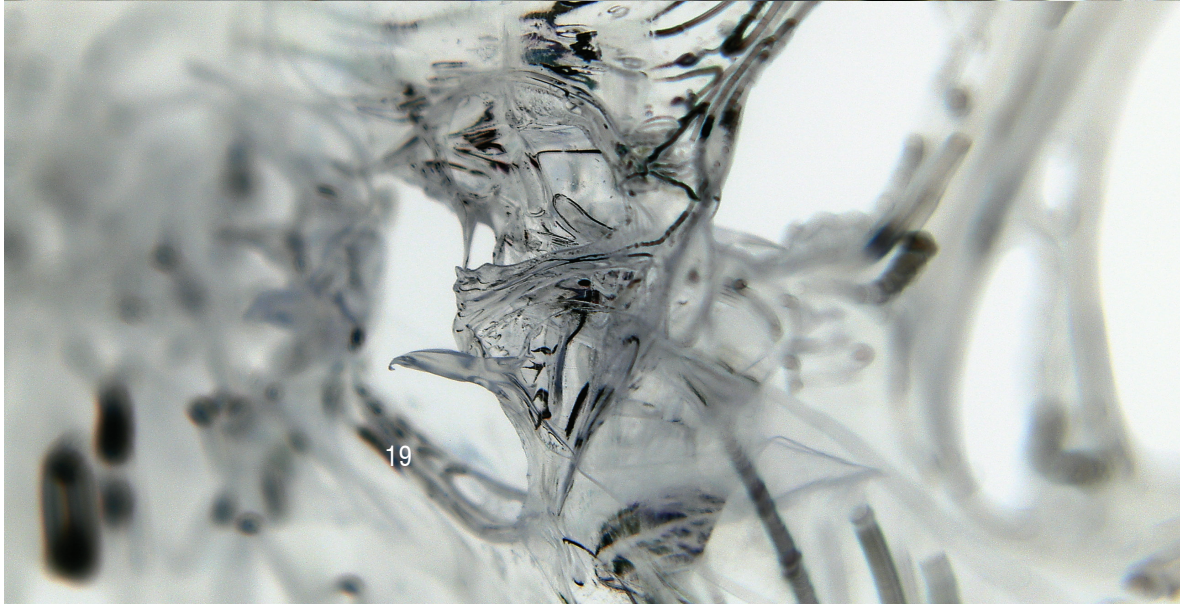



f.015

Carravaggio 'Narcissus'

NARCISSUS: the Emergence of Doubling

So thin the veil we almost touch each other.

- *Ovid* from "Echo and Narcissus"

(Gregory & Ovid 2001, 99)

The Narcissus myth propels us out of the body of water where desire was arising. It is here, along the skin of water, that doubling emerges in a deep-rooted relationship with the human condition of desiring.

Narcissus is bent over the water's surface completely enraptured with what he sees there (f.015) - as if beneath a veil, a darker version of himself stares back at him with equal intensity. *This*, the most beautiful thing he has ever seen, arrests his gaze; he cannot blink, he cannot breathe. He bends even closer, and with his lips he breaks the surface to touch it with a kiss. But the kiss is not returned. His beloved distorts and is sucked into unreachably dark depths, returning only hesitantly as Narcissus pulls back. In the wake of the water's obliteration of his beloved, Narcissus becomes aware that the other he desires is his own reflection, yet he does not turn away. What was a



f.016

by Author 'Withheld : Photo 1'

beautiful temptation is now, with the impossibility of touching it, an obsession. Narcissus is transformed by the impossibility of the unmediated experience of kissing himself; his yellow locks hover as petals in a perennial gaze over the surface of water to attempt this union in perpetuity.

For Narcissus, sight does not touch, it distances. To close the distance he must cross the skin of water, the divide that keeps his beloved just out of reach. Only then might he enjoy the unmediated experience of kissing himself, of coming into contact with the complete and clear understanding of himself that Eros intimates resides in its depths. What makes this a phenomenon of doubling is that Narcissus does not see a 'reflection,' he sees an unknown and untouched aspect of himself, he imbues it with a meaning that is intimately tied to his desire to 'engage with himself' in a way that might make him whole.

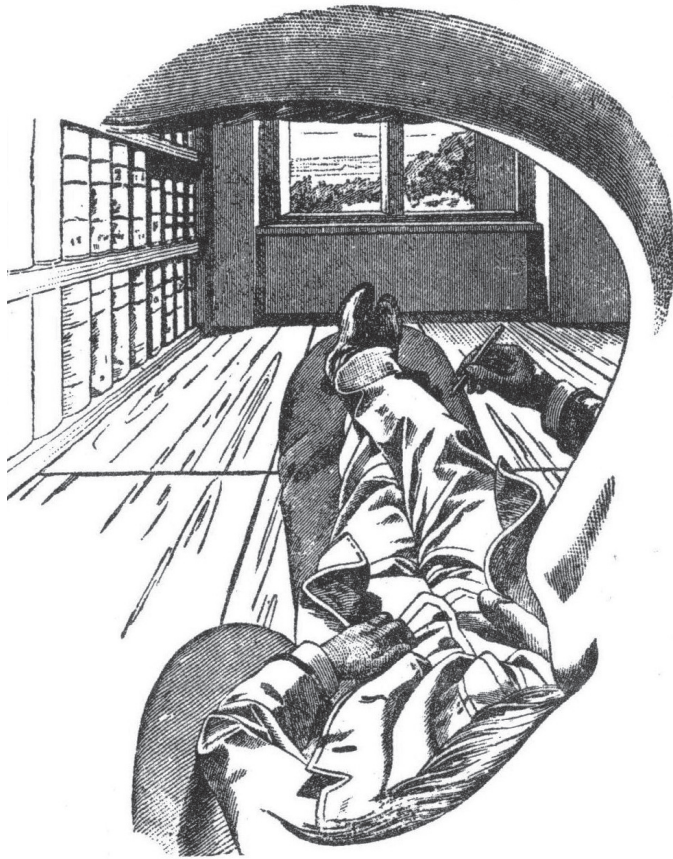

f.017

Ernst Mach 'Inner Perspective'

This is an ancient myth that is still strongly embedded within our culture today. In it, the water's surface is a powerful metaphor for that contact boundary where our experience of doubling engages with our desire to an entrancing affect, it emphasizes how rooted and perpetual the act of desiring is in the human condition. The role of doubling here is pivotal because it keys into the specific desire to understand and engage with ourselves completely in a way that manifests itself in the spatial and material realm outside our inner being.

This doubling into the skin of water complicates what we understand as our personal boundaries. I assume that everything I am is inside of me, and that everything I am not is outside of me. For the most part, and most people still think in Cartesian terms, this boundary, between inside and outside me is assumed to be along the surface of skin. When, as in the Narcissus myth, we behold ourselves in a space that we assume is outside of ourselves (the realm of the Other) we become enthralled (f.017); our grasp on how we exist in the world becomes complicated.



FOR ONCE THEN SOMETHING

-Robert Frost

Others taught me with having knelt at well-curbs
Always wrong to the light, so never seeing
Deeper down in the well than where the water
Gives me back in a shining surface picture
Me myself in the summer heaven godlike
Looking out of a wreath of fern and cloud puffs.
Once, when trying with chin against a well-curb,
I discerned, as I thought, beyond the picture,
Through the picture, a something white, uncertain,
Something more of the depths--and then I lost it.
Water came to rebuke the too clear water.
One drop fell from a fern, and lo, a ripple
Shook whatever it was lay there at bottom,
Blurred it, blotted it out. What was that whiteness?
Truth? A pebble of quartz? For once, then, something.

(online-literature.com/frost/745)

f.018

David Spriggs 'Manifold'

In an experience of doubling is the intimation that there is something that we have yet to become or understand - that there is something out there that we must engage with.

The poetic associations with doubling are steeped in an uncanny self-awareness that is rife with an uncertainty concerning the limits of our being and our ability to imagine the potentials that lie just beyond the surface of water. In Robert Frost's poem "For Once Then Something," he writes of "something" just beneath his watery reflection, a glimmer of the "uncertain" (f.018). Is Narcissus really enraptured with his reflection in the surface of water, or is he trying to see past it, to the unknown in desire's depths from which it might have come?

An experience of doubling can generate an uncanny atmosphere that beckons one to embrace the unknown glimmering just beneath that divide, coaxing us, as Ted Hughes' poem does, to engage in the protean movements of desire, "to alter...and to somehow tangle with" it.

WOODMAN AND ARTAUD: Doubling between Figure and Ground

Between me and it is something between.

I and it will both be gone soon.

Between me and it are love and desire.

As we are abstract are we still here.

- *William Bronk* "Persistent Abstract"

(Bronk 1997, 184)

f.019

(opposite top)

Antonin Artaud 'Portrait of Paule Thevenin or Paule with Irons'

f.020

(opposite bottom)

Francesca Woodman 'From Angel Series, Italy, May 1977 - August 1978'



WOODMAN AND ARTAUD: Doubling between Figure and Ground

Gone are the days when humanity was completely 'united' in a single belief system. Whole societies have moved from poly- to mono-theism and back; the world has gone from flat to round, from the center of the cosmos to a speck in the multi-verse; scientific progress is built upon disproving formerly 'true theories' while continually discovering more and more about ourselves and our world that we never knew existed. As each of these ways of contextualizing ourselves within our greater milieu is re-formulated, people become split; not everyone can agree on what the true way of being is.

The practice of architecture itself, the design of how people live and physically navigate the built environment, has undergone so many re-writes stating 'this, no wait *this* is the way to live' that it has been itself fractured into a multitude of manifestoes on the 'right way' of dwelling in and experiencing space. With so many philosophies, sciences and theories co-representing our being, no one has been able to recover the confidence in 'truth and reality' we once had.

This uncertainty in the context of our being and fate has set us to the task of recuperation. This is not a just a nostalgia for simpler times. The uncanny affects of doubling are of the sorts that imply that there might indeed be some sort of greater understanding to be had in the depths of its experience. The following modernist artists use the phenomenon of doubling to place us on the brink of a collapse from which they hope a new affirmed being will arise. Like Narcissus, a doubling entices them to

bend over the surface of water to embrace what desire holds in its depths. But unlike Narcissus, they do not pull back at the shock of its surface. Their works are attempts to purposefully disturb the surface of that which holds them back from the full emersion of their being.

The human subjects in the works of Francesca Woodman and Antonin Artaud desire an almost impossible transformation that will affect their passage into a 'truer' state of being that for them lies somewhere between their body (figure) and its greater milieu figure (ground); for Woodman it is between body and the material environment, for Artaud it is between his body and the abstraction of the world. They attempt to catalyze this transformation by engaging this traditionally conceived divide through a doubling that seems to disturb the boundary, that tries to expand and occupy it as a way to engage with that 'truth and reality' that Eros seems to hold in its depths, that might maybe lie in the inbetween.

When looking at their selected works side by side one is struck by how complimentary they are; as if Artaud's heads (f.019) could complete Woodman's bodies (f.020). Both depict the body-as-flesh as anatomically incomplete and both infer through the presence of a doubling of some aspect of the self into the environment, a transformation that might indicate the trace of another type of existence free of the figure / ground delineation.

FRANCESCA WOODMAN (1958 - 1981)





f.022

Francesca Woodman 'From Angel Series, Italy, May 1977 - August 1978'

Then at one point I did not need to translate the notes; they went directly to my hands.

- *Francesca Woodman*
(Sollers & Woodman 1998, 60)

f.023

Francesca Woodman

'Then at One Point, Providence, Rhode Island, 1976'



then at one point i did not need
to translate the notes; they went
directly to my hands

WOODMAN'S DOUBLING

Francesca Woodman (1958 - 1981) spent much of her life doubling her own body into the negative space of the photograph, a space in which she staged imagined narratives using her own body as subject. Not only was the medium of photography a means of doubling herself into another virtual space, in selected photographs (f.021, f.022) she explicitly depicts a further doubling of her photographed body into the matter of its environment.

Here the doubling of the body's form into the material of the foreground occupies the center of each composition, amassing an air of great importance. Here a doubling as an immolation (f.021) and as a burrowing (f.022) are laid, as if evidence, at the feet of the subject's incomplete body-as-flesh. Behind this implicit heat and coarseness, the body-as-flesh is clean and posed at ease. Are these doublings an afterimage - the result of a transformative event in which the body-as-flesh attempted a union with the material external to its nakedness? Doubling here is read as an active coupling between the figure and its ground - its presence indicative of a desire to transform, to pass on into some other space where they exist homogeneously intertwined.



We are two unknowns in a single equation, we
and our world, functions one of the other.

- *William Bronk*

(Tymieniecka 1985, 335)

f.024

Francesca Woodman

'From Space ², Providence, Rhode Island, 1975 - 1976'

WOODMAN'S FIGURE / GROUND

There is a definite tone of sublimation in Woodman's notations (f.023) in which a rarefaction of bodily experience is desired. Her works express a longing for a type of simultaneity; a more direct, unmediated experience of what is external to the body. It is in this annotated photo that we come to understand her subject's desire for the amalgamation of the two. Both figure and ground are partial; the subjects' heads (the part of the figure that is most associated with identity) are missing; parts of the background are torn and thrust into the foreground (f.023, f.024). What has more presence than either figure or ground is the active consolidation of the two. In these photos doubling is used to create a type of composite body, a dissolving agent, blurring the line that divides the body and the wall.

Woodman's use of doubling is evidence of her body's attempts to unite with the room; a transformative event that cannot be fully witnessed or grasped - an enthralling and enigmatic translation of the subject's body into a realm 'external' to it. This doubling initiates the pushing open of a virtual doorway onto the gap she sees between her body and the material environment. Through this we catch a glimpse of a rarefied existence where the boundary between the body-as-flesh and its greater milieu is no longer a hindrance to the 'translation of notes.'

ANTONIN ARTAUD (1896 – 1948)



f.025

Antonin Artaud 'Portrait of Paule Thevenin or Paule with Irons'

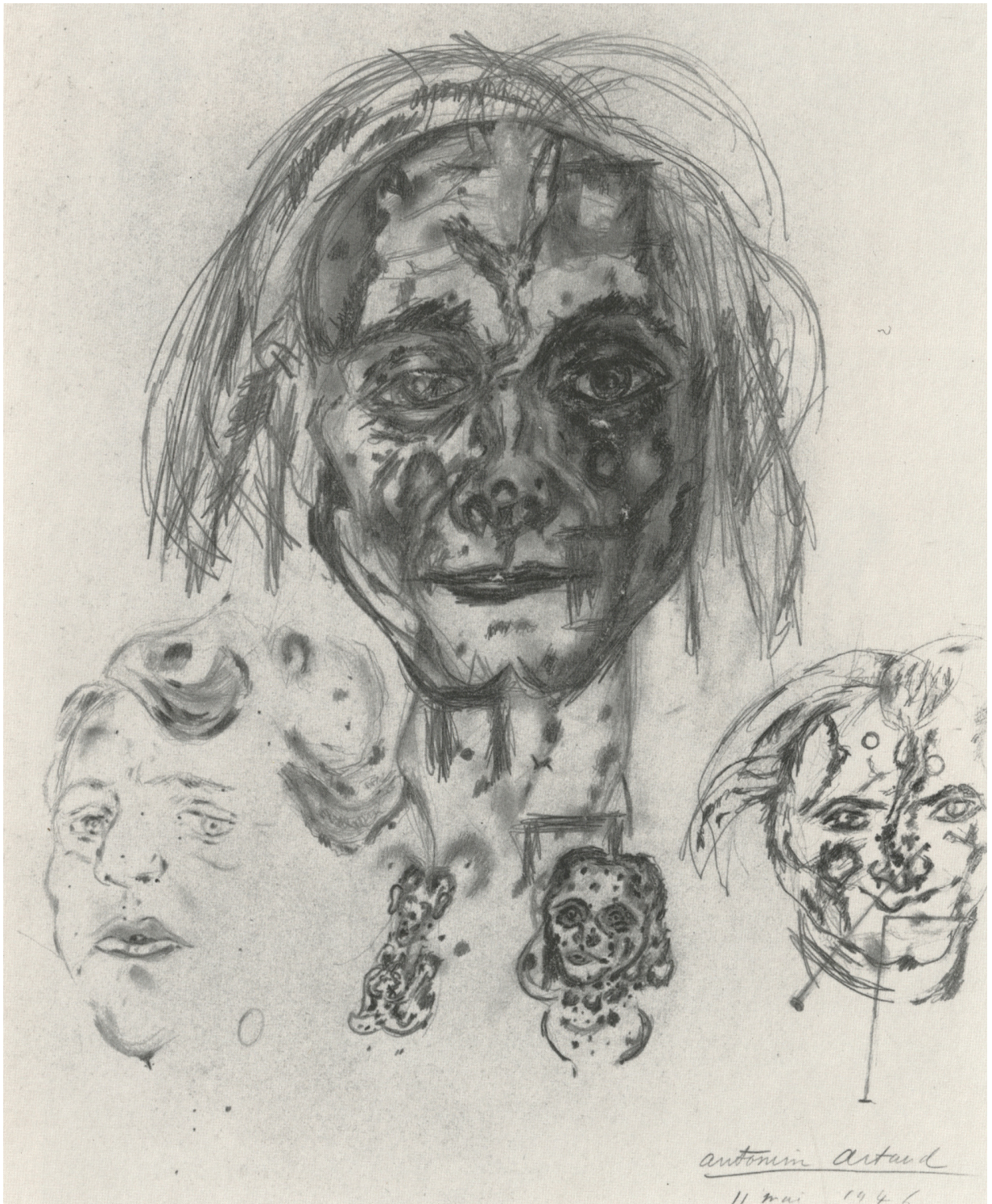

f.026

Antonin Artaud 'Self Portrait 11 May 1946'

When we speak the word 'life', it must be understood we are not referring to life as we know it from its surface of fact, but to that fragile, fluctuating center, which forms never reach. And if there is still one hellish, truly accursed thing in our time, it is our artistic dallying with forms, when instead we should become as victims burning at the stake, signaling each other through the flames."

- Antonin Artaud (Artaud 1958,13)

f.027

Antonin Artaud 'Spell for Roger Blin'



ARTAUD'S DOUBLING

Antonin Artaud (1896 – 1948), writer/actor/director/artist, used doubling as a metaphor to structure a belief system in which birth is the first of many doublings that transform us into impure representations of the pure primordial beings we once were. In "Artaud, defecation and birth" Leo Bersani identifies this doubling at birth as a "falling away" which causes a "split between the self and the world as well as between the self and its own history" (Bersani 2004, 102). Artaud's obsession with doubling is then extended to encompass all things that fall away from the body, including defecation, language (f.027), representation, etc., for as Bersani states again, "Artaud lives in terror of the 'articulated body,' of anatomical extensions which decentralize our physical being" (Bersani 2004, 102). Where Woodman's doubling is material evidence of an attempt to wed the earth, Artaud's doubling is a prison that holds us back from a transcendental escape from it, a fear that finds its way into all his works.



f.028

Antonin Artaud 'The Theater of Cruelty'

Artaud's portraits (f.025, f.026) are anti-artistic, anti-stylistic stabs at drawing the true human face, "a form that has never corresponded to its body, that started off as something other than the body" (Artaud & Rowell 1996, 95). Starting with a light penciling, his heads are harshly disconnected at the neck, scribbled over and obsessively erased then redrawn. It is as if the hard gestures of drawing open lesions from which the true face might emerge. The emanations from the center of the heads are indicative of faces surfacing from beneath faces;



It means that burning is a magic act, and that we must consent to burning, burning in advance and immediately, not a thing, but every thing that represents things for us, in order to expose ourselves to being burnt up whole.

- Antonin Artaud (Artaud & Hirschman 1965, 98)

f.029

Antonin Artaud 'The Projection of the True Body'

each layer erupting with another that is ultimately nebulous and un-drawable. It is not clear what this true face is, only that it is 'formless and fluctuating,' freed by a destructive force much like the fire Artaud uses to destroy the doublings in later works by the puritanical process of burning (f.027, f.029). One can imagine the figure burnt at the feet of Woodman is Artaud (f.021).

ARTAUD'S FIGURE / GROUND

The drawing "The Theater of Cruelty" (f.028) depicts the clearest relationship between Artaud's figure and ground. Here, both the body and the world external to it exist as nested Russian dolls, as if both were nothing more than a layering of coffins reinforcing a holding back from true being. On closer inspection works like the portraits forge a subtler relationship; one must be careful not to overlook the presence of the paper on which his works are drawn, the paper itself being a different type of coffin - an expansive and empty ground his heads are lost in.

For Artaud burning is a purifying process of homogenization just as much as the dismemberment of the human body into bloody pieces of bone and flesh (f.029). Burning and scratching through both figures (figures being both body and text) and ground/ page opens a wound that unites the two in cruelty. Only by exposing and totally destroying all doublings can one recover the formless truth that Artaud sees screaming to be released.

The true body is the body burnt up, the spiritual body. The unity is not organic-natural unity, but the unity of fire. 'But first the notion that man has a body distinct from his soul is to be expunged; this I shall do by printing in the infernal method, by corrosives, which in Hell are salutary and medicinal, melting apparent surfaces away, and displaying the infinite which was hid.'

- Norman Brown & William Blake

(Brown 1966, 183 - quoting William Blake)

CONCLUSION

Both Antonin Artaud and Francesca Woodman present in their works a desire for a transformation that will gain them access into an unmediated, or 'truer' state of being. This seems to present itself as a critique of the boundary of the traditional figure/ground relationship in which doubling plays a key role both in the works' coming into being as well as a phenomenon that their subjects are imagined to experience.

When looking at their lives in relation to their works, it is hard not to see the doubling that occurs there. One wonders if the intense doubling and desire that these artists felt deeply enough about to investigate so intimately in their work, might be somehow linked to their tragic turn their lives took, or if it was simply a matter of who they were. Woodman produced an intense series of photographs entitled "On Being an Angel," a few years later she threw herself from an upper story window, committing suicide at the age of 22. It was mentioned in the previous section that Artaud "was afraid of all things that fell away from the body, including defecation;" is it a curious coincidence that deemed a madman by many, Artaud, a social outcast, spent the majority of his life in and out of asylums, dying painfully of colon cancer at the age of 51? These may be ironic examples of correspondence, however there is something to be said here about the doubling of the artist's life into their oeuvre, a desire to engage in a form of expressive doubling, that of creating, of putting your energies into a medium of self articulation.

Like Narcissus, Woodman and Artaud might have become so enthralled in what they saw in Eros' depths that its temptation pervaded their lives to overflow into a very affective set of works that not only disturbed the surface, but were active attempts to stay there, face submerged below the skin of water even at the risk of drowning. And maybe therein lies what is so disturbing about doubling and desire – how far you are willing to go.

The doubling that resonates in their work is used to critique what we have constructed as a way of being in the world, a condition in which we are bounded by the traditional figure/ground relationship between our body and building and our body and the world. For Woodman and Artaud, this bounded condition is that which prevents them from a completeness of being, or understanding of the world. While their works can be interpreted as direct attempts to bridge this limitation, it is interesting to note that they go about achieving it in distinctly different, almost opposite ways, adopting different stances on what doubling means for them and the method by which they orchestrate the approach to their transformation. For Woodman, through her body's altercation with the material environment, doubling becomes a method of melding figure and ground into a material and intimate amalgam. For Artaud, doubling is a hindrance; he cruelly destroys the doubling of both figure and ground through an alchemical process of purification - wounding and burning until nothing but an abstract primordial 'something' remains. While Artaud yearns for the ethereal void, Woodman tries to insinuate the material of her being into the interval between figure and ground, a gap in which they mingle in a mass of matter.

If between desire and the unknown promising completion is some divide which is kept in place to ensure desire's perpetuity, for Narcissus it might be called the skin of water, whereas for Artaud and Woodman it is the divide drawn between figure/ground. This is a dynamic that finds its way into architectural discourse, for the struggle to cross the skin of the water is also the struggle to cross the divide we have created between body and building; the struggle to craft some meaningful and intimate relationship between the two, to both expand and bridge this interval and make it alive with a sense of mutual desiring. However, it is hard to approach the creation of a meaningful figure/ground relationship as Artaud did and end up with anything ma-

For all this magnetism, all this poetry, and all these direct means of spellbinding would be nothing if they were not used to put the spirit physically on the track of something else, ... give us the sense of a creation of which we possess only one face, but which is completed on other levels.

And it is of little importance whether these other levels are really conquered by the mind or not, What is important is that, by positive means, the sensitivity is put in a state of deepened and keener perception...

- *Antonin Artaud*

(Artaud 1958, 91)

terially and spatially tangible. Max Jacob, a contemporary surrealist moving in the same circles as Artaud once said:

If it yearns after primordial truths,

The spirit destroys itself;

If it weds the earth it thrives. - from *Philosophies*, No1. 1924

(Conrads 1970, 89)

If it is through doubling that the artists try to engage with the desire of Eros, in which they see an unmediated complete state of being, for Artaud it is through an ontological doubling that propagates such an abstract approach that the door at the point of contact is locked and must be smashed in. On the other hand, Woodman's doubling is a wedding of the earth, a phenomenological doubling that expands and dilates the line between figure and ground, suggesting the material possibility of entering into the gap of a door that is already half open (f.030).

As such, this author finds Woodman's conception of doubling a more provocative and essentially architectural approach to the critique of the dichotomous divide that is so embedded in our conception of our architecturally bounded bodies. This thesis proposes that we as architects have something to learn about the approach to this dichotomy from a close reading of the doublings that occur there. Perhaps a study of the spatial and material characteristics of different types of doublings would help us as architects to soften our conception of and approach to designing in the interval between figure/ground. Could the purposeful incorporation of the phenomenon of doubling into the designed environment work to blur the line between body and building to create an atmosphere in which the two come together, perhaps even enabling us to dwell in a closer relationship with our desire? The following chapter keeps these questions in mind as it attempts to mine specific spatial and material characteristics out of different kinds of doublings.

f.030

(opposite top)

Francesca Woodman 'Providence, Rhode Island, 1975 - 1976'

f.031

(opposite bottom) by Author 'House of Doors'



I thought
we stood at the door
of another world
and it might open
and we go in.

- *William Bronk* "The Conclusion"
(Bronk 1997, 171)

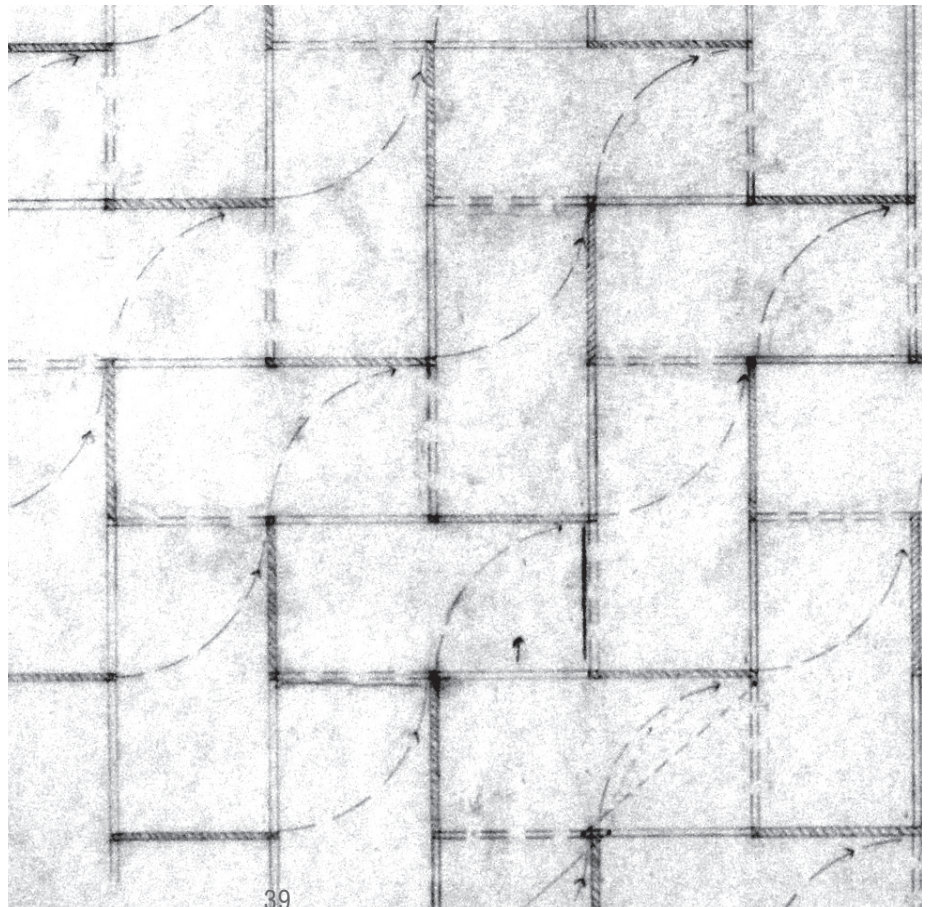

Poetic imagination allows us to explore the being of man considered as the being of a surface, of the surface that separates the region of the same from the region of the other. ... Then, on the surface of being, in that region where being wants to be both visible and hidden, the movements of opening and closing are so numerous, so frequently inverted, and so charged with hesitation, that we could conclude on the following formula: man is half-open being.

- *Gaston Bachelard* from *The Poetics of Space*

(Bachelard 1994, 222)



f.032

(this page & opposite) by Author 'Tone of the Void : Film Stills'

INTRODUCTION

If doubling engages us in a critique of the figure/ground relationship that intimates the possibility of softening or even entering into the divide between them, we can see through Woodman and Artaud's work that these doublings can have differing characteristics as well as approaches to expanding the interval (i.e. Woodman's doubling unites with matter, Artaud's is cruelly destroyed). When these doublings spatially and materially probe this boundary, they can let in a subjective tone that oscillates between light or dark (f.032), creating an affective atmosphere that can swing from the universal to the subjective, lack to potentiality and gloom to iridescence.

This second chapter invests itself in exploring a variety of doublings in order to gain a greater insight into the diversity of its psychological, material and spatial characteristics. If an experience of doubling causes us to enter into a virtual state of 'think-



ing about ourselves,' this thesis proposes that an approach to such an analysis might start by looking at types of doubling that are drawn from methods by which we come to understand our figure's relationship to its greater milieu, through the ontological – the body's relationship to the primordial; the oneiric – the body's relationship to its dreams and imaginings; and the phenomenological – the body's relationship to its direct physical engagement with the world.



f.033

Unknown Artist 'Allegory of the Cave'

ONTOLOGICAL DOUBLING

Ontology is the study of the nature of being in the world in which distinctions are made between reality and illusion in an effort to define the first principles or 'truth' of our existence. Plato's "Allegory of the Cave" might best describe this pursuit of truth:

The inhabitants of a cave sit chained with their backs to its opening (f.033). Between the opening and their backs is a fire that casts the shadows of a parade of things onto the wall in front of them. Without seeing the fire or actual parade they are unable to comprehend that the shadows are merely representations of actual objects; they are completely ignorant that their conception of reality is one-dimensional. When a prisoner is freed of the cave, he sets out to achieve an enlightened understanding of his being in the world by examining the observable things around him in stages (f.034). First, images in shadow and reflection are revealed to project nothing but vacuity and misrepresenta-

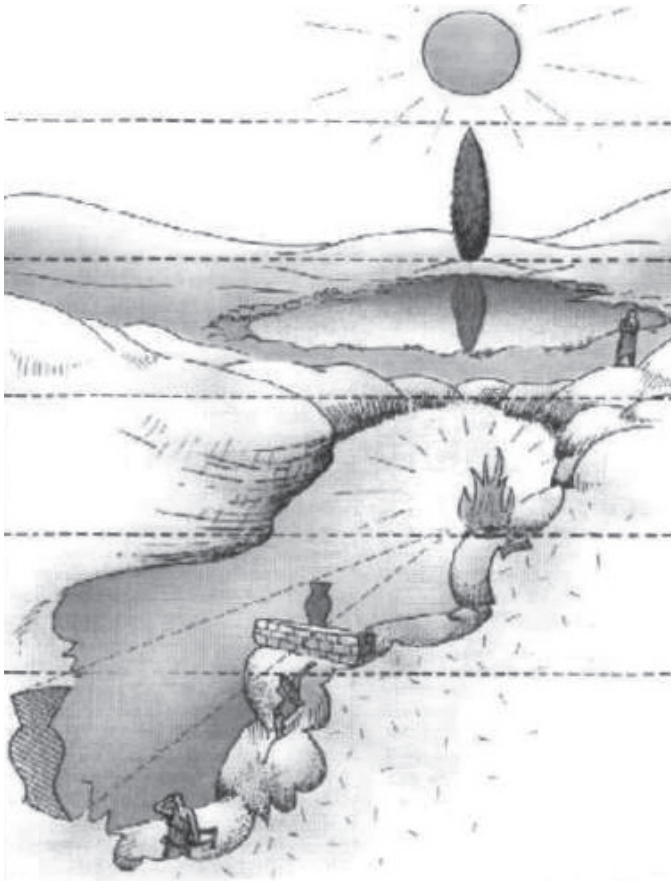

f.034

Unknown Artist 'Untitled' : Plato's Hierarchy of Realities

tion. As he goes on to experience the objects of these images, he finds the mathematical objects of “the heavenly bodies and the sky at night” at the root of these, only to end his search looking “directly at the sun, ... just as it is” (Stoichita 1997, 23).

Plato has hierarchically detailed the parade of illusions we face in an ontological pursuit of ‘truth’ and how we might methodically unmask them by moving from observing the lowest ‘reality,’ shadows, to end with the highest, the sun. Each illusion is a perceived doubling of ‘true’ existence, a transmutation of reality that with each consecutive doubling descends further into the cave, becoming increasingly inauthentic and increasingly dark.

This dark/light gradient is further underpinned by Antonin Artaud’s writings some 2400 years later. In many of his works Artaud associates his fear of doubling with the darkness of

“Indeed the simile of the cave, precedes, represents, indeed symbolizes the desire for knowledge.” (Stoichita 1997, 22)

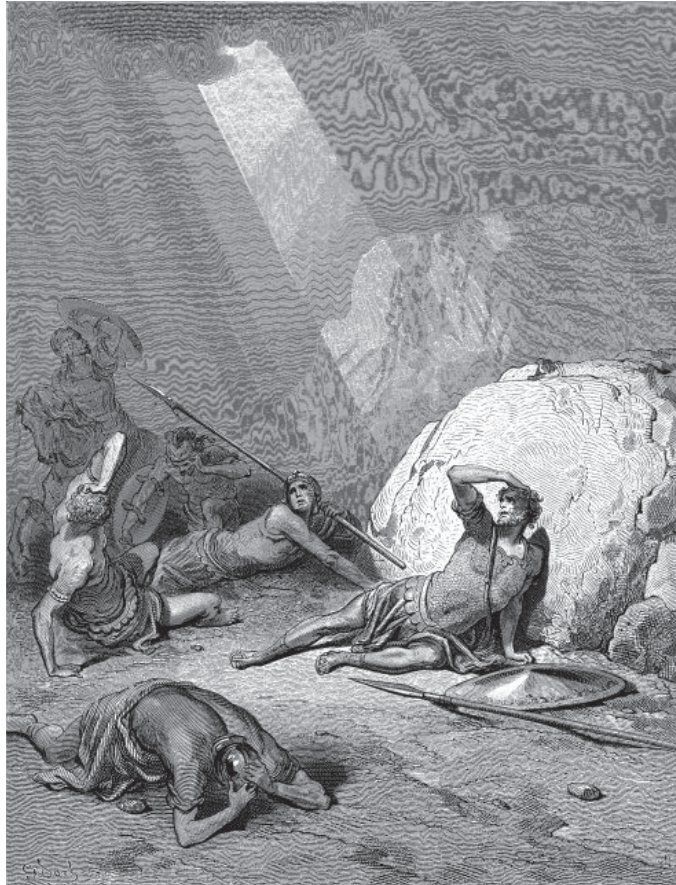

f.035

Gustave Doré 'Conversion of Saul'

Every real effigy has a shadow which is its double...

- *Antonin Artaud*

(Artaud 1958, 12)

shadows; to experience a doubling in shadow is to experience a cruel illusion of a primordial reality we have lost touch with. Artaud states: "I no longer wish to be a Believer in Illusions," (Artaud 1958, 85) and suggests that the only way to stop the continual doubling of oneself further and further away from a 'completeness of being' is to be burnt up whole.

This brings to mind another allegory where direct contact with painful illumination brings about a revolution in ontological beliefs. On the road to Damascus, God speaks to the unbeliever Saul through piercing rays of sun, blinding him and then unblinding him through an act of blind faith (f.035). Experiencing a doubling between the darkness of his unbelieving self and his enlightened being changes his name from Saul to Paul.

However, while blazing light may be the catalyst for contact with a truth and reality yet unknown, let us not forget that it is the blazing light in the cave that generates the shadows, or unrealities, in the first place. Plato's allegory and the parable of Saul



f.036

Samuel van Hoogstraten 'The Shadow Dance' - detail

seem to be as much of a play between shadow and light as they are on which way one is looking - away or into the fire. Unless, like Artaud, you know shadows are outside the cave as well, and choose to walk directly into the flames.

Through Plato's and Artaud's abhorrence of in-authenticity and the unbeliever Saul's spiritual re-birth, ontological doubling seems to refer to the transformation of an abstract and immaterial truth into muted and inauthentic matter. To engage with the primordial 'truth' of our existence we must be blinded by the sun or martyred by fire. This battle between the false and true's most pregnant atmosphere is fleshed out by a fiery flickering; a dance in which shadows pulse in and out of our perception, stretching and retracting across space with harsh movements of light (f.036). An experience of ontological doubling might be expressed by a masking or deflecting that generates a gradient between light and dark, whereby the body's doubling into shadow or reflection is expressed as degrees of clarity and obscurity that hang in space as series of curtains that must be lifted.

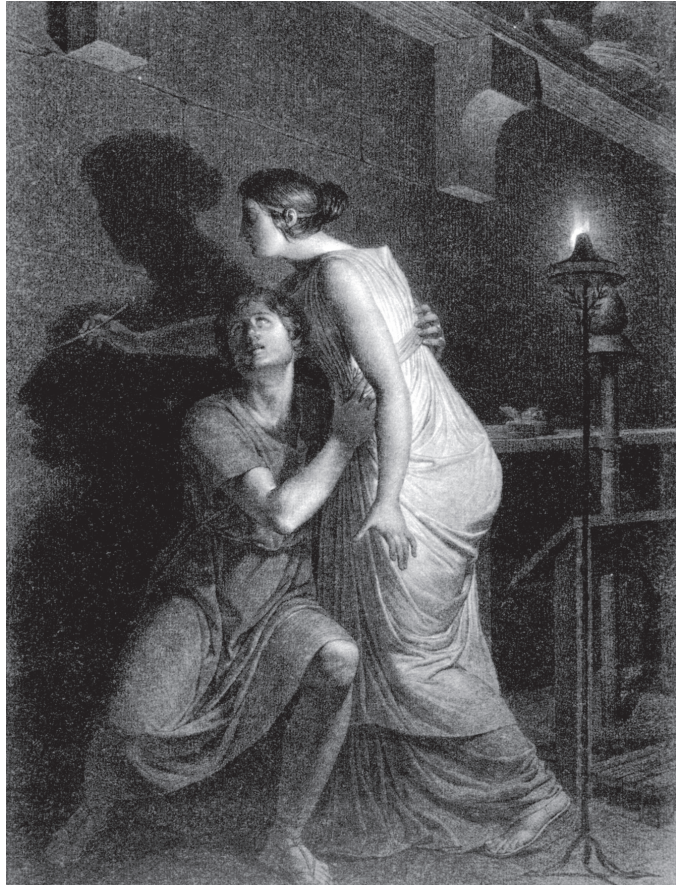

f.037

Joseph-Benoît Suvée 'The Invention of the Art of Drawing' - detail

ONEIRIC DOUBLING

The oneiric is that which pertains to dreams or the virtuality of the imagined realm. To begin this exploration of oneiric doubling we begin with a legend concerning the origin of the modelled portrait from *Book 35* of Pliny's *Natural History*, a legend that has accumulated great significance in its many retellings and interpretations. The legend features a Corinthian maiden anticipating her lover's departure (f.037). Wanting to keep some aspect of him present to her, she traces his shadow cast by a lamp onto the wall of her house. From this tracing her father, a potter, fills the lines with clay and hardens a bust of it in the fire (Pliny & Bostock & Riley 1855, 283).

Many of the retellings have been romanticised, citing this variously as the origin of drawing, painting, and even art itself (King 2004, 629). This thesis' interest in it is perhaps that which has instigated such romantic exaggeration of its influence; that



f. 038

Paul Nadar 'Daguerre (+ Honoré de Balzac)'

it weaves an imaginative connection between the lover's being and his rendered likeness. This is an oneiric doubling that replaces the lover's absence with material, a transformative doubling of the maiden's desire for his being through matter - from body, to wall, to coal tracing, to pottery. By the mid-19th century a person's appearance as it was substantiated in material external to the body "seemed to promise entry to their essence, their inner spirit" (Warner 2006, 160). It is here that oneiric doubling begins to emerge as a doubling that transfers a person's vital substance into a space outside itself.

Balzac, a 19th century novelist and playwright, believed that bodies consisted "of a series of ghosts, in an infinity of superimposed layers, foliated in infinitesimal films, in all the directions in which optics perceive this body," and lived in fear that the daguerreotype's mirror-polished surface was able to "de-

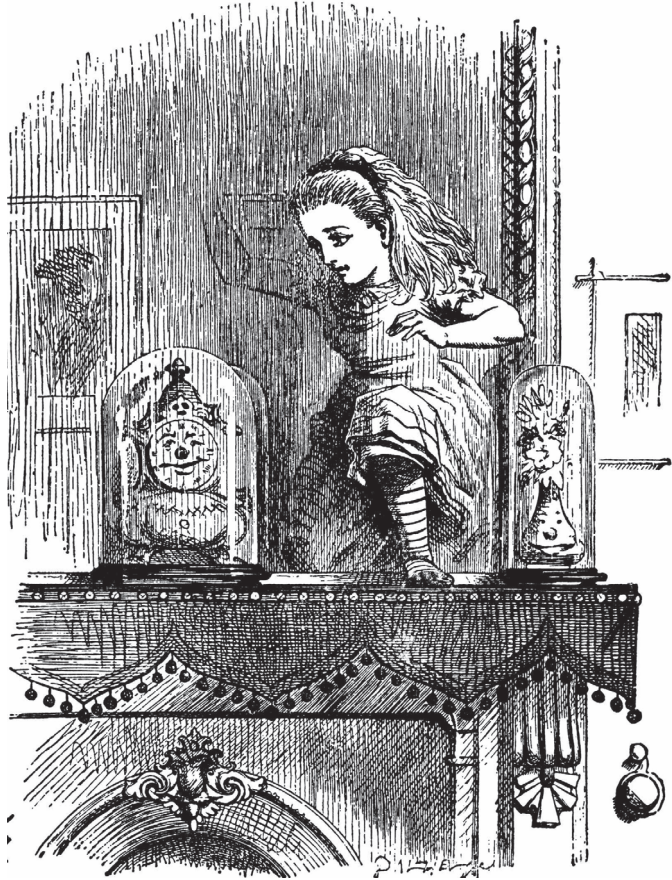

f.039

Sir John Tenniel 'Alice Pushes Through the Mirror'

"I wonder if I've been changed in the night? Let me think: was I the same when I got up this morning? I almost think I can remember feeling a little different. But if I'm not the same, the next question is 'Who in the world am I?' Ah, that's the great puzzle!"

- Lewis Carroll

from *Alice Through the Looking Glass*

(Carroll 1974, 37)

tach, and retain one of the layers of the body on which it focussed" (Warner 2007, 86) (f.038). This was a prevalent fear that surrounded photography's beginnings; having your photo taken was akin to stealing away your soul. Just as Narcissus' doubling into water (f.015), the photograph was a filmy surface from beneath which your soul stared back at you, trapped in a realm delicately dislocated from this one.

The novel *Alice Through the Looking Glass* by Lewis Carroll is a prime example of a realm 'on the other side' of this one where another Alice and world exist (f.039). Not only is there a doubling of Alice Liddell into the novel as the fictional character 'Alice,' but fictional Alice experiences a doubling of herself into another realm when she passes through the looking glass. These are spaces of pure fantasy separated by the thresholds of the page and the glass – oneiric doublings that are in direct

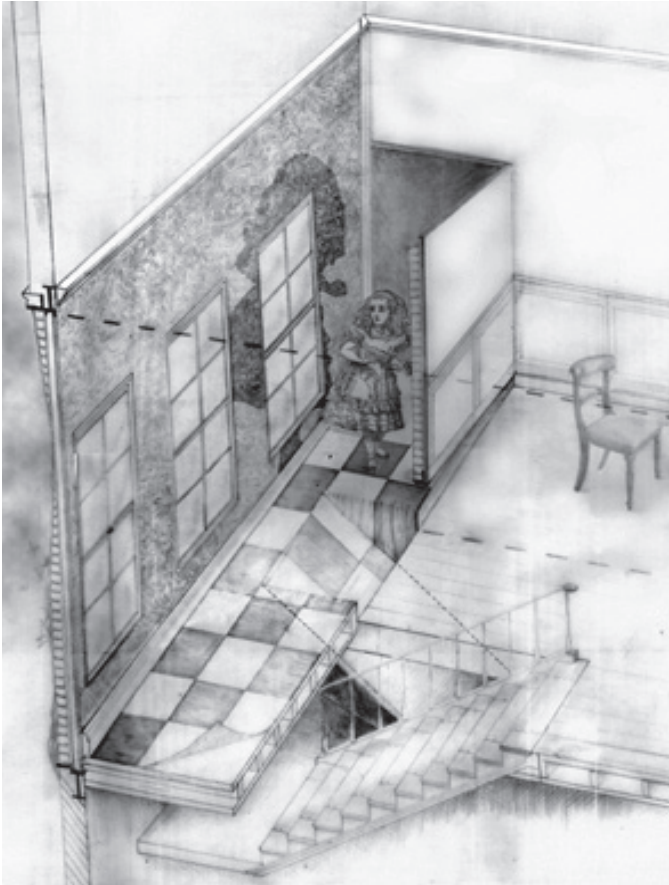

f.040

Juliet Quintero 'Alice's House : Axonometric'

contact with Carroll's and fictional Alice's dreams, where the rules of their respective realms are at variance with each other but are no less real on their respective 'sides.'

Juliet Quintero's student project "Alice's House" (f.040) articulates this doubling's tendency to manifest itself through spatial separation. Through the section of the house we can see the house itself is split into 'real' and 'imagined' spaces occupied by the doubling of Alice. The arrangement is akin to the workings of a mirror - the real and imaginary spaces are each perceptible to the other and although existing spatially side by side, the means of crossing from one to the other is indiscernible. Francesca Woodman's photographs also take part in this spatial displacement - by pushing her own body through the frame of the lens (f.048), she gives herself over to the composition of her own imagined realm.



f.041

Anish Kapoor 'Ishi's Light'

This is where existential oppositions – real and unreal, permanent and transient, physical and metaphysical – become our moment of truth. In his work, Kapoor attempts to capture space between consciousness and the body. The work opens to something that points beyond what is there.

- *Shirley Madill* on Anish Kapoor's work
(Madill 2006, 27)

Anish Kapoor is a contemporary sculptor whose use of reflective material in works like 'Ishi's Light' (f.041) and 'S-Curve' (f.042) cause the viewer to see themselves distorted in the interiority of the piece. It suggests that the tension between the body faced with its doubling into an almost identical realm is productive of an affective atmosphere in which "the sudden and unexpected return of something that was once familiar and homely" (Kapoor & Vidler 2004, 18) resonates between the two. Working with "states of material that push the physical boundaries of their physical status" (Kapoor & Baume 2008, 47), Kapoor "makes the status of objects uncertain, but at the same time also makes the subjective viewer uncertain. In this way we reflect on our uncertain state as subjects . . . It literally throws us off balance as it suggests a world beyond our grasp" (2008, 54).



f.042
Anish Kapoor 'S-curve'

Contrary to the ontological, in which doubling masks a primordial reality, oneiric doubling presents the miracle of physically engaging with otherwise invisible aspects of our being (our love, soul, dreams). As such, this doubling can be considered to manifest “an invisible reality within the visible realm” (Tiffany 2000, 80), creating the concurrent existence of two realms that are both equally ‘real.’ Its primary spatial and material characteristics tend to be articulated by the slight distortion and displacement between one side and another. The threshold between them is both slight and precarious; through the flickering of shadow, the delicacy of film and the transparency vs. reflectivity of glass and steel, we catch a glimpse of an uncannily similar ‘something’ on the other side. If ontological doubling is the proverbial wool over our eyes, then oneiric doubling generates an uncertainty that revolves around our imagining to see through it to the glimmer of an invisible realm on the other side.

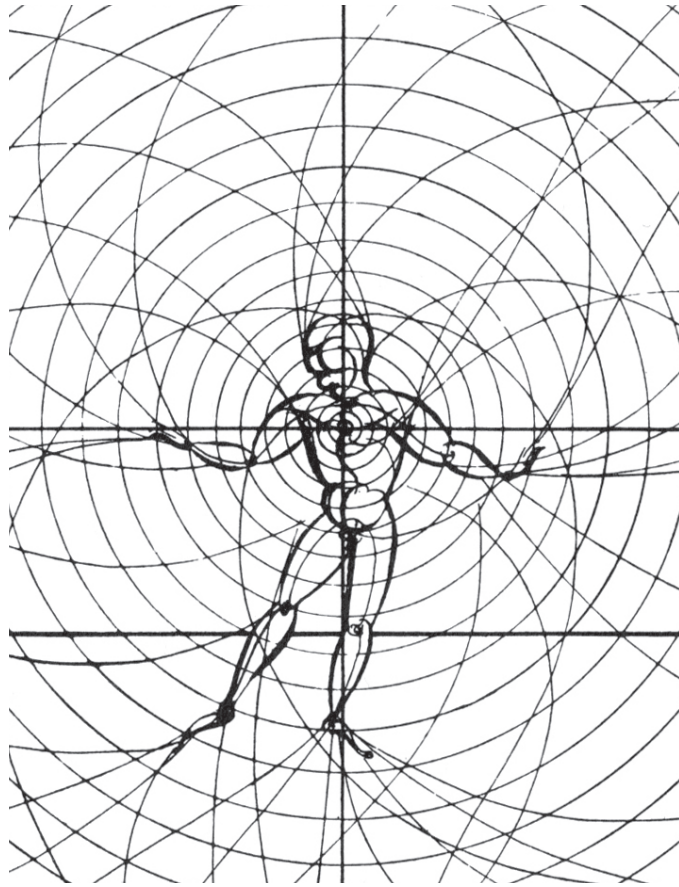

f.043

Oskar Schlemmer 'Egocentric Space Lines' - detail

PHENOMENOLOGICAL DOUBLING

Oskar Schlemmer's diagram 'Egocentric Space Lines' (f.043) geometrizes the human body's sphere of motion into something akin to a web, implying that between itself and the environment is a realm of "hyper awareness and cognitive sensitivity" (Howes 2005, 97). It might be read as diagram of a phenomenological understanding of one's being in the world, one gleaned from the subject's embodied and sensed responses to its surroundings. As such, a phenomenological doubling could be understood as the one that is rooted in the sensate body and its actions as they mingle with its environment.

Schlemmer's diagram is a charting of this interval between body and environment, that resonates with the doubling of the body that takes place through movement - a mapping of the body's potentials into the breath of space as it flows around and with it. Erin Manning, a professor of art and philosophy,



f.044

Norman McLaren 'Pas de Deux' - film still detail

writes beautifully on this doubling of the body in movement as a phenomenological doubling that enmeshes the external world with our beings (f.044):

“There are always at least two bodies. These two stand close, facing one another, reaching-toward an embrace that will signal an acceleration of the movement that has always already begun. The movement within becomes a movement without, not internal-external, but folding and bridging in an intensity of pre-acceleration. ... Preacceleration because there can be no beginning or end to movement. Movement is one with the world, not body/world, but body-worlding.” (Manning 2009, 13).

Theater director and historian Thanos Vovolos writes about a similar phenomenological enmeshing of our insides and out-



f.045

Thanos Vovolis 'Aeschylus, Suppliant Maidens, Epidauros Festival'

sides through the ancient Greek tragic mask. In “The Voice and the Mask in Ancient Greek Tragedy” he suggests that these masks were performative helmets (f.045), formed “as an extra resonance chamber for the voice of the actor,” creating a consonance in the space between the mask and the actor’s head whereby “the mask turns out to be an instrument for the actor to control the direction and volume of the voice, the rhythm, the articulation and the tone” (Vovolis 2003, 76). What’s more is that the dynamics of the voice in the mask induces a phenomenological doubling in which the increase in awareness creates “a heightened state of being, a state of communication in which the actor senses the experience of a bodily and vocal expansion ... creating a prerequisite for the metamorphosis of the actor into his or her stage gestalt ... At this point the outside, ‘the mask’, and the inside, ‘the human face’, merge” (Vovolis 2003, 78).

The potential movements of the body in space coupled with the metamorphic experience of the voice in the mask suggest that we might gain greater insight into the material and spatial



f. 046

Francesca Woodman 'Self-Portrait Talking to Vince' - detail

expression of phenomenological doubling by looking at the dynamics of the airs in and around the body.

Douglas Kahn, a contemporary writer focussing on the history and theory of sound, sees the voice's role in a phenomenological formulation of self as pivotal: "Moreover the voice is a good way to project perception into the world because it shares sound with hearing. The sound of the voice returns if not in the voice itself then in the unison of utterance and audition, and it creates the constitution and collapse of space required of a sentient getting outside ourselves" (Kahn 1999, 28). Francesca Woodman's *Self-Portrait Talking to Vince'* (f.046) depicts the shape of her voice as it leaves her mouth to reach out to Vince - is this the apprehension of her own voice external to her body?

A sensual encounter with the voice external to the body was explored in 1885 by Margaret Watts-Hughes when she breathed a sustained note into a wide-mouthed tube. By pouring coloured glycerin onto the membrane she discovered that her voice did

My voice defines me because it draws me into coincidence with myself, accomplishes me in a way which goes beyond mere belonging, association, or instrumental use. And yet my voice is also most essentially itself and my own in the ways in which it parts or passes from me. Nothing defines me so intimately as my voice, precisely because there is no other feature of my self whose nature it is thus to move from me to the world, and to move me into the world.

- Steven Connor

(LaBelle 2006, 103)



f.047

Margaret Watts-Hughes 'Daisy Form'

more than expected, her singing into it gave birth to a peculiar, floral shape in the liquid, a shape that would morph into new and peculiar forms with each modulation of duration and tone (f.047). Calling these forms 'voice-figures,' her work presents itself as a stunningly beautiful catalogue of a phenomenological doubling that drew, from the potentials in the airs of her own body, the metamorphic shape of her own voice.

Even Antonin Artaud, consumed with defining himself in ontological origins, believed the breath/scream to be the one true phenomenon born and sensed by the body that could elevate one to the higher planes of enlightenment. He saw in breath all the potentials of being through which pass "all the possible states of blood and mood the whole battle of splinters and prickles of the body made visible" [see full quote p59 (Artaud & Hirschman 1965, 172)]. Indeed, in air lie all the potentials to activate the body's senses: we can be touched by the wind, while sound, scents, temperature and moisture, light and darkness and even tastes are all carried in its currents.

The potentials within the airs of the body are documented in Roger Bacon's book *The Multiplication of Species* where he describes the manifestation of ephemeral 'peelings off' from our

Now there is in the human breath sudden shifts and breaks of tone and, from one scream to another, abrupt transferences by which the openings and soarings of the entire body of things can be suddenly evoked, which can support or liquefy an organ like a tree you might prop up against the massy mountain of its forest.

Now the body has a breath and a scream by which it can act on the decomposed lowest depths of the organism and visibly transport itself up to those highly brilliant lighted planes where the Superior Body is already waiting for it.

In this operation, in the blindest depths of the organic scream of the catapulted breath, there

pass all the possible states of blood and mood,

the whole battle of splinters and prickles of the body made visible,

emerging from among false monsters of the schism

of spirituality

and sensibility.

- *Antonin Artaud*

(Artaud & Hirschman 1965, 172)

bodies as ‘radiant species’ in which “the orders of being and appearance converge” (Tiffany 2000, 202). This ‘species’ does not have “dimensions of itself but is produced according to the dimensions of air; ... by a drawing forth out of the potentiality of air” (Tiffany 2000, 203). Bacon’s use of the word radiant in conjunction with air brings to mind the aura that surrounds the human body. This coloured field of different energy densities permeates and emits from the body; the manipulation or even apprehension of the aura is quite literally the body’s phenomenological experience of itself as an ephemeral chromatic doubling that extends out from itself - an energized potentiality in air.

Phenomenological doubling is drawn forth from the potentials offered up by the emoting and sensing body itself. The above works surrounding its manifestation suggest that its material and spatial expression is intimately tied to the dynamics of air, the ephemeral force that gives the body life, manifesting itself in the auratic energies of the body and its breath as it passes through the body and extends out from it. An experience of phenomenological doubling activates what both Schlemmer and Vovolis identify as a charged realm between the body and its environment where we can engage in an intimate merger between our insides and our outsides.

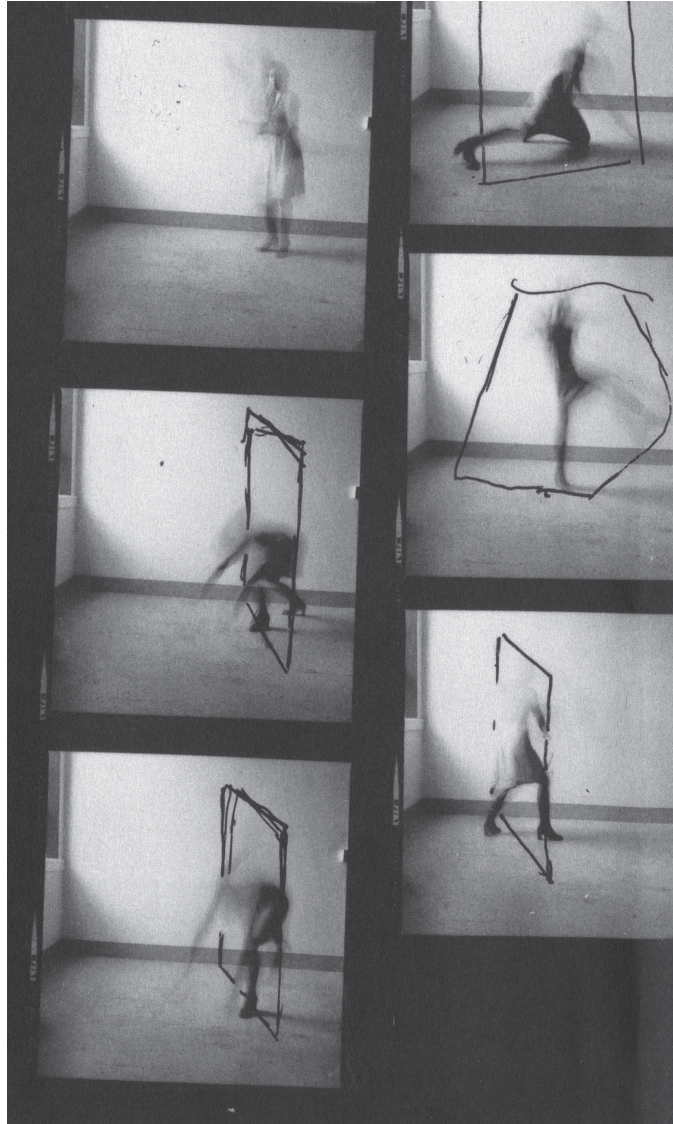

f.048

Francesca Woodman 'Study for Space², Providence, Rhode Island, 1975 - 1978' - detail

CONCLUSION: Doubling, a Portal Metaphor

Through ontological, oneiric, and phenomenological approaches we frame the context within which we approach this unknown. This chapter set out to examine both the experiences of doubling within each of these contexts and the spatial and material characteristics involved in their manifestation. Through this investigation this thesis has come away with a greater understanding of ontological doubling as occurring between the body and its relationship with the universal, manifesting in the play between light and dark; oneiric doubling as occurring between our body and its imaginings, manifesting as a spatial displacement at an

ephemeral threshold; and phenomenological doubling as occurring between our body and its sensed environment, manifesting as a aerated folding together of inside and out. One might even conclude that in doubling lies the enmeshing of opposites in which the body's union with its milieu or context is brought about through the melding of dark to light, this side to that, and inside to out.

In doubling there seems to be a portal metaphor, an inference to the possibility of passing not through these opposites, but into an expanded space between them, a potential space of confluence and consonance where the two are no longer separate. Francesca Woodman's photo series pictured left might be the perfect analogue to the forces and tendencies this thesis has read into the phenomenon of doubling. Her photographic body seems to meld with the room as she steps and tumbles through imagined portals (f.048). Francesca Woodman's work has remained throughout this thesis, for this author, the most compellingly architectural work with doubling due to its intense engagement with matter itself. In her work we feel the desperate desire to connect with our surroundings, incorporated, considered - whole. After studying the doublings in the ontological, oneiric, and phenomenological, the doublings I take part in everyday start to take on new meaning, or rather less.

The new 'interactive' and 'responsive' architectures, the future environments in which we are meant to live, seem to be, in their manipulation of body-centric inputs and outputs, quite dependant on the phenomenon of doubling, but what kind of doubling is it? What am I taking away from an experience of a wall changing colour by my movements, or for that matter, someone else's 5000 miles away? Are these doublings disseminating my being or strengthening my body's connection to space and matter? Are they having any impact at all?

Giving the significance of an experience of doubling leans heavily towards concerns about the nature of our being in space and the innate desire that drives us, might a conscious consideration of a material doubling in the design of architecture strengthen a body's feeling of connection to the built environment, make it feel a part of it, or foster a greater sense of meaning?

Our poled complicity wires the charge of the world
- discharges it. Are we hooked
to some motor? Not I. Astral I,
I burn with the universe, blast with desire.

- *William Bronk* "Polarity"

(Brock 1997, 187)

DESIGN INTENT

The following design chapter picks up on the questions that arose at the end of the previous chapter: might a study of doubling add to an architect's understanding of the relational space between the body and its environment? Would developing an appreciation for doubling as it manifests itself spatially and materially be a valuable addition to a designer's poetic palate?

This chapter presents three design explorations as provocations - an opening to approach these questions in a visual and material way. While the previous chapter ended by inquiring into the role doubling might play in the emergent practices of digital responsive and interactive environments, the designs executed here are not explicitly rooted in these practices. Instead, they find expression through the base materials of architectural design, light and space, in order to gain a fundamental understanding of ephemeral atmospheres that might help inform the meaningful design of the digital realm in the future. Just as Oskar Schlemmer recharacterized the body in motion "as a space-making being" (Feuerstein 2002, 231), light can also be a space-making phenomenon "reveal[ing] a building's contours and shadow, its depth" (Ritchie 2007, 149); in the following design explorations the body and light together make a compelling 'pas de deux' that is fundamental to the architectural spaces that unfold.

"The history of architecture can be described as the story of the way day and sunlight enters into buildings and reveals through shadow the spatial composition and forms within. Sunlight allows space and form of architecture to change. Through light and shadow architecture acquires shape and meaning. Light reveals a building's contours and shadow, its depth."

– *Ian Ritchie*

(Ritchie 2007, 149)

The aim of these designs is to construct architectural fictions in which doubling plays a key role in producing atmospheres that key us into the thing that impels us... desire and the unknown it opens onto; that might connect us with that hyper-aware realm between the body and its environment.

To achieve this, the process of designing itself participates in a doubling - that of projecting oneself into an imagined inhabitation of the project by entering it through a fictional narrative. If fiction is a journey into what might be; to participate in fiction is to give oneself over to potential happenings, to the unknown. We hope that through fiction we can deal with issues that are unclear to us, challenge us, puzzle us. Fictional narrative becomes

central in both the process of developing the designs through model, and in the presentation of the work as a projected film.

The design process foregoes the common practice of drawing first, to find its form through a process that is unbounded by the intellectualizing that must go on because of the two-dimensionality of the paper (or screen). The practice of translating a particular reading of doubling through modeling is pursued as it escapes the mediation of the page to engage the designer in an unmediated experience with the material being constructed.

INITIATOR AND PRECEPT

Each design exploration is initiated by a reading of photographs by Francesca Woodman. The material & spatial characteristics of the doublings in these works are translated into sculptural explorations in hopes of provoking a “persistent sensation that embodies the event” (Deleuze & Guattari 1994, 176).

MODELING AND NARRATIVE

The three-dimensional materiality of the model enables the designer to engage in a doubling of themselves into a tactile, imaginative inhabitation of the construction. Here, the immediacy of the process of designing is experienced sensually by the designer, in an almost-real occupation of the thing being produced. While for many architects “modeling is a fundamental technique in the search for form” (Moon 2005, 90), here modeling is used in the search for a narrative that coheres with an event of doubling from which the form is allowed to freely emerge, in other words, the model’s overall aesthetic is completely martyred to achieve effects that are less about form and more about unearthing an evocative and meaningful event.

To begin, the human figure and the event of its doubling as catalyzed by three perceptual properties of light - shadow, reflection and iridescence - are used as material participants in the making of scaled models that share in the persistent tendencies of the initial perceptual investigations of Woodman’s doubling.

f.049

by Author 'Eos Collage'

(with John Gibson's 'Sculpture of Aurora')

Her primary role was as a guide and, like her sister Selene, her form was changeable: as goddess of the dawn she announced the appearance of the sun, her brother Helios, whom she then accompanied on his rounds, first as Hermera (day) and then as Hespera (evening). - (Smith and De Morgan 2002, 141)

But is he who opens a door the same as he who closes it the same being? ... there are two 'beings' in a door, that a door awakens in us a two-way dream, that is doubly symbolical.

- Gaston Bachelard

(Bachelard 1994, 224)



Here, the choice to guide these doublings using the myth of Eos (f.049), a metamorphic goddess personifying the two polar variants of daylight, gives the emerging choreographies a shared armature to wind their narratives around. This ensures a coherent undertone that runs through the three designed narratives that both aids the designer's decisions and allows the viewers of the work to perceive some sort of connection between them.

Eos, guide to the sun god's chariot, has like Bachelard's door two beings within her - an opening that is Dawn, personified as Hermera and a closing that is Dusk, personified as Hespera (Smith and De Morgan 2002, 141). Her cardinal opposition of herself in East vs. West incarnations informs the method by which the events within the models are captured and presented. Each of the models are designed with two apertures from which to witness a shared event of doubling (f.050); the event seen through one side varies slightly from the event as it unfolds on the other to produce subtle differences.

The diurnal cycle that Eos leads is a powerful correlative to de-

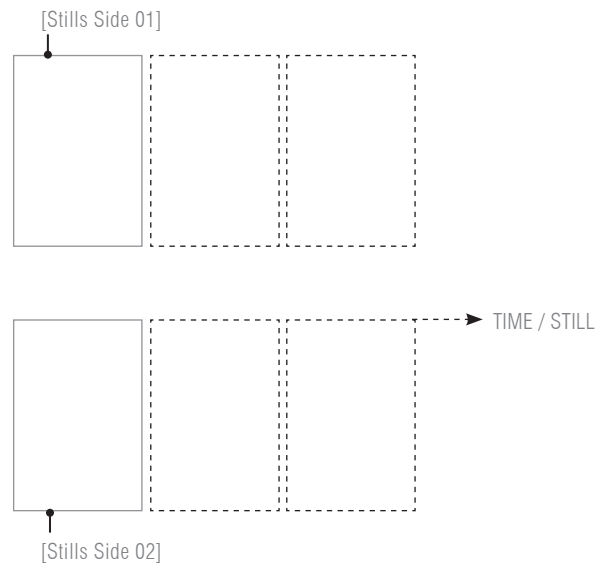
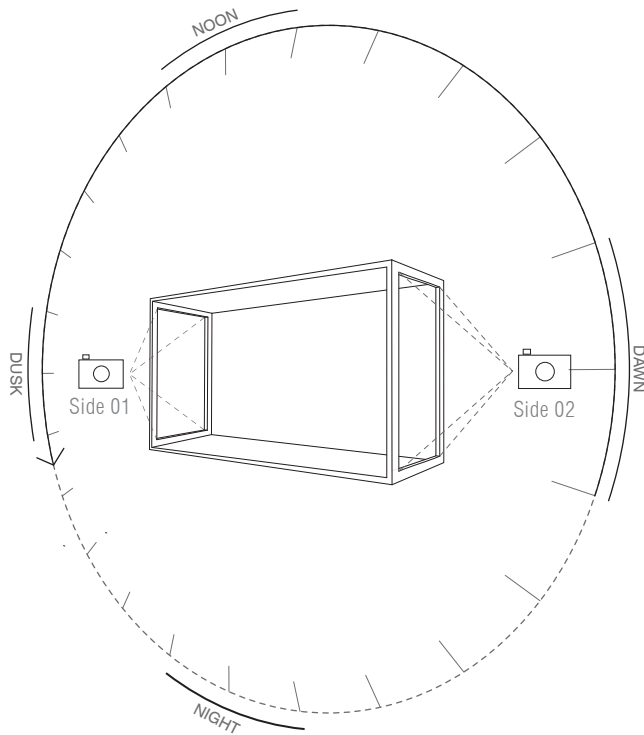

f.050
by Author 'Stills Diagram'

sire's cyclical nature. From day to night, Helios, the light she draws across the heavens, is that which manifests her doubling in an arc that swings between light and dark. This celestial journey is simplified into three 'scenes' to give some context to her doublings in the three models: Cycle 1- the Portal: the opening and closing of Heavens polar gates; Cycle 2- the Passage: travel through the arc of the sky; Cycle 3- the Cusp: the exchange of breath at high noon. By choreographing the movement of figure and light through the models, the three cycles of doubling as presented and dissolved by shadow, reflection and iridescence are documented via a series of still photographs that correspond to each of the two sides of the models (f.050). These are then edited into three diptych films on independent loops (f.051) meant to be projected at a human scale and arranged to face each other, so that the viewer of the work standing between them can experience the doubling of these events (f.052).

The selection of materials and composition of spatial relationships in the models for these cycles are developed to establish a tension between two strangely similar female figures that oc-

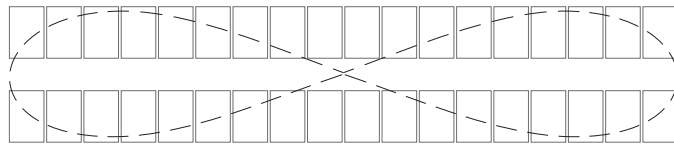

Cycle 1

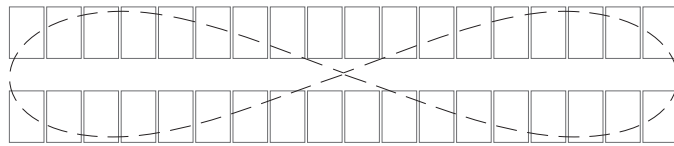

Cycle 2

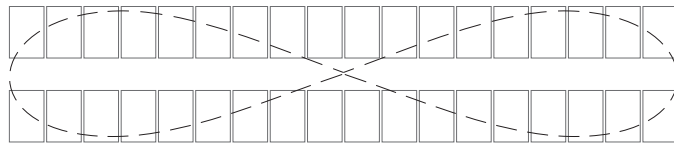

Cycle 3

f.051

by Author 'Cycle Diagram'

copy them. The similar female figures are chosen so as not to confuse the desire that doubling evokes for the pursuit of a heterosexual union. Cursed by Aphrodite, Eos is fated to love perpetually, her desire jumping from mortal to mortal as fast as she can catch them. In this desire, is a sense of infinite duration, an impelling forward motion towards an unknown future - and once we near...our desire doubles the distance; Eos may as well be chasing herself across the heavens. Desire has been cast in this thesis all along as one that engages with the enigmatic unknown; the doubling of a self similar aspect of oneself outside one's conceived limits creates a desirous interval between the two. The two females are a metaphor - just as Eos is, or my sister and I, or the similar rooms that initiated this thesis - for the enigmatic aspect of ourselves that impel us.

A tension is cultivated between the similar figures in the constructions by maintaining some sort of material or spatial divide that reinforces the tensions seen as coincident to the ontological, oneiric and phenomenological doublings in the previous chapter: that between light and dark (Cycle 1 - filling one room or the other), this side and that (Cycle 2 - coincident passageways),

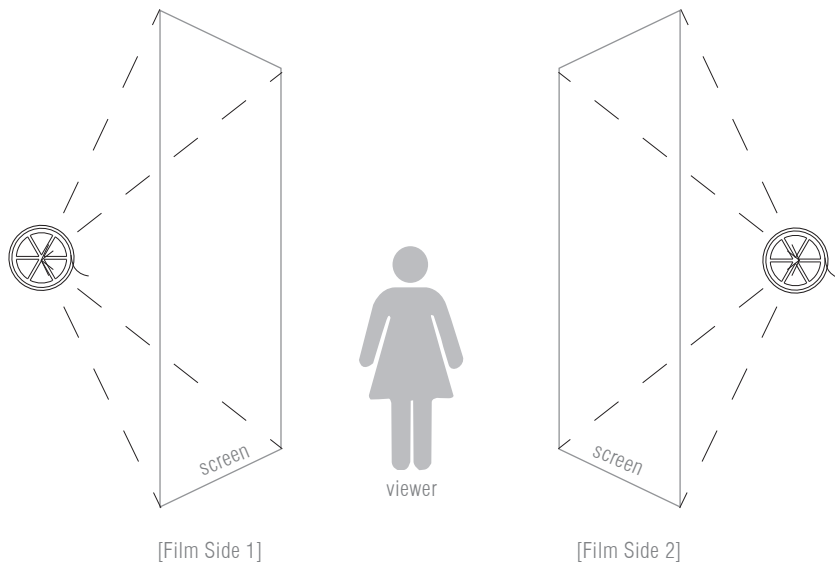

f.052

by Author 'Projection Diagram'

and inside and outside (Cycle 3 - the interval between inhaling and exhaling). This is further underpinned by the ephemeral qualities of the material choices which react to light to create a diaphanous dilation of the threshold condition that is always between them.

DRAWING

Drawing of the project occurs after the video is composed, not as an accurate representation of what had been made, or of how to build it, but as diagrams that make the trajectory of forces at work during the event visible in order to understand the dynamics of the doublings as they move between the figures and the material of the constructions. These diagrams trace the doublings in relation to the diurnal cycle as the waxing and waning of light catalyzes their appearance and disappearance.

The three design explorations aim to generate a specific affective atmosphere in which the signification of our hopes and anxieties in desiring are brought out in the doublings' unfolding in time. The making and the projection of these doublings are detailed in the following pages.

Cycle 1

Reflection



f.054

by Author 'Cycle 1 : Doubling at Dusk, Portal 2'

Cycle 1

Reflection

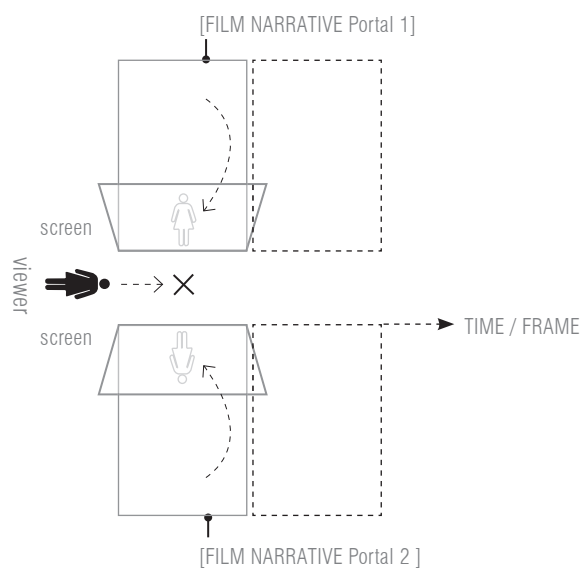

f.055

by Author 'Spatial Arrangement of Video Projection'

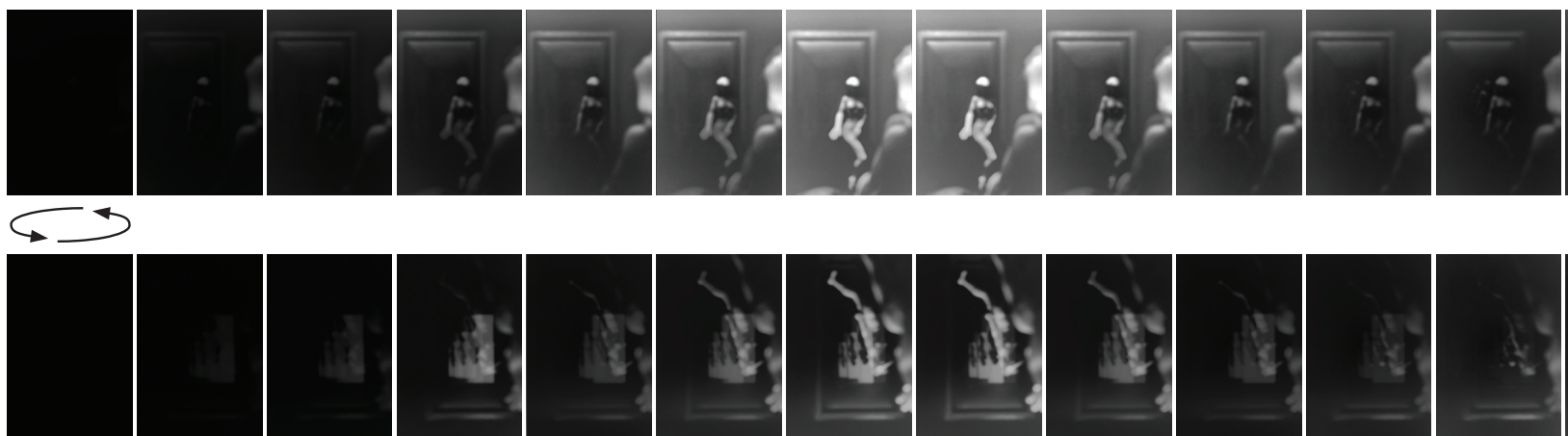

f.056

by Author 'Cycle 1 : Narrative in Stills'

REFLECTION: THE PORTAL

SYNOPSIS Eos opens and closes the celestial gates, releasing and receiving the chariot of the sun. During this stage Hermera and Hespera stand behind facing opposing glass gates. As they alternate opening and closing the gates, each perceives the other's presence as an increasingly faceted doubling across the portal between them. As Hermera breaks the day to push the sun's flame through the gate in the East, Hespera sees her faceted doubling across the gate that she yet holds closed. As Hespera opens the gate in the West to receive the sun's waning light, Hermera sees Hespera's doubling collapse like cards into encroaching darkness.

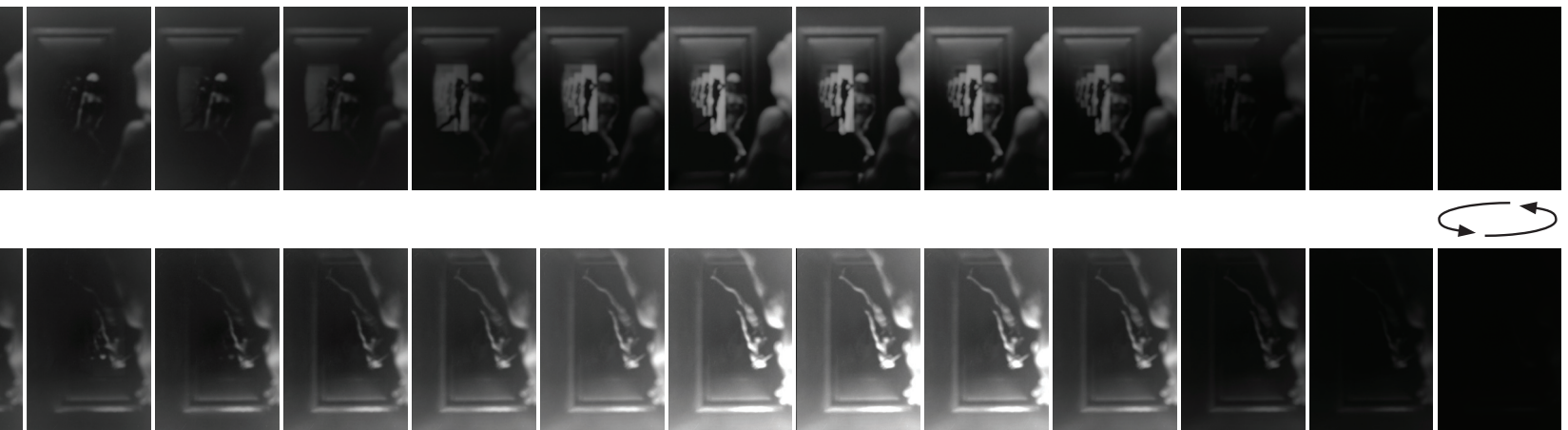

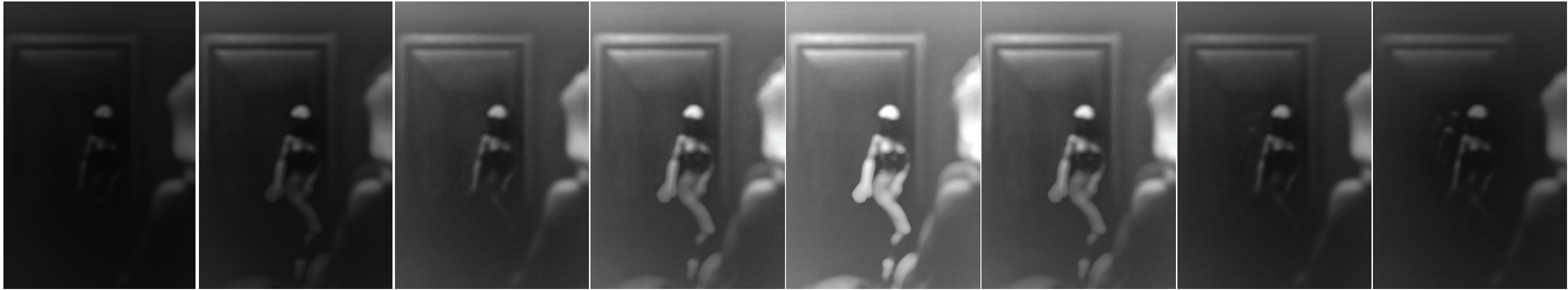

DAWN

NOON

PORTAL 1



NOON

DAWN

PORTAL 2

Beneath deep darkness,
I shoulder a dent into Night's side.
It fractures as I, the Beginning of Brilliance,
emerge accompanied in the opening to the sky,
doubling into the persistent planes of approaching day.

Slowly, day collapses as a cool breeze blows the dark
back into the sky. Leaning into the descent,
I grasp on to the celestial decrescendo,
and fill the yawning gates with
my own facets fading.

f. 058

(next page) by Author 'Cycle 1 : Doubling, Detail'

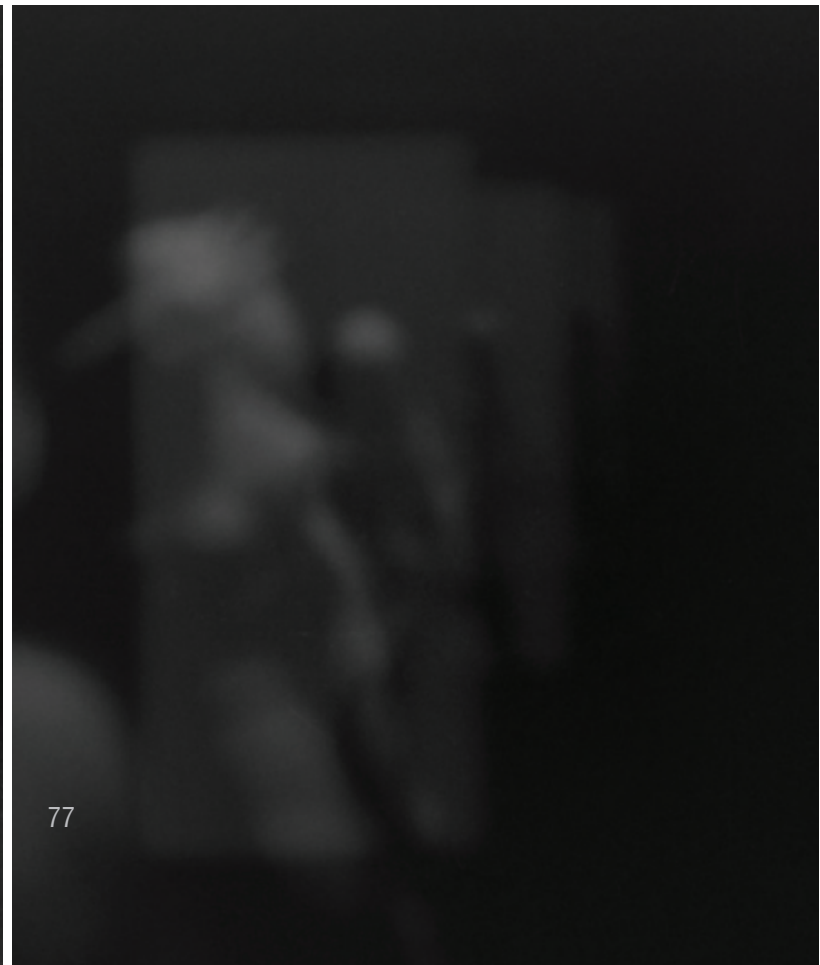
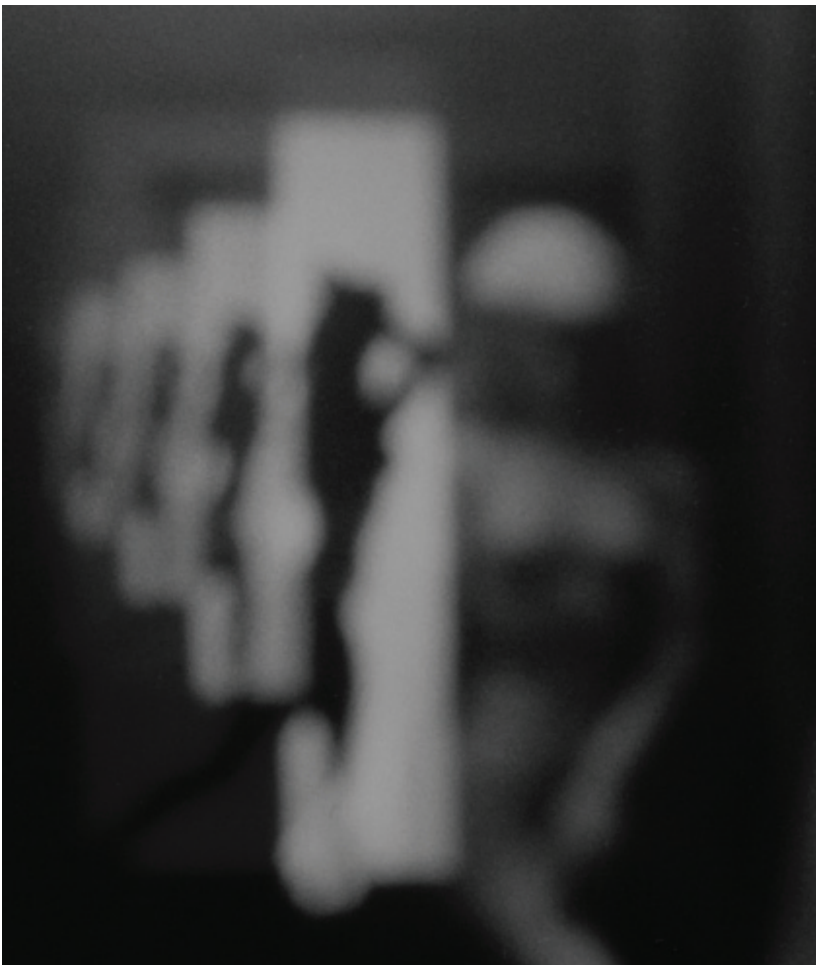
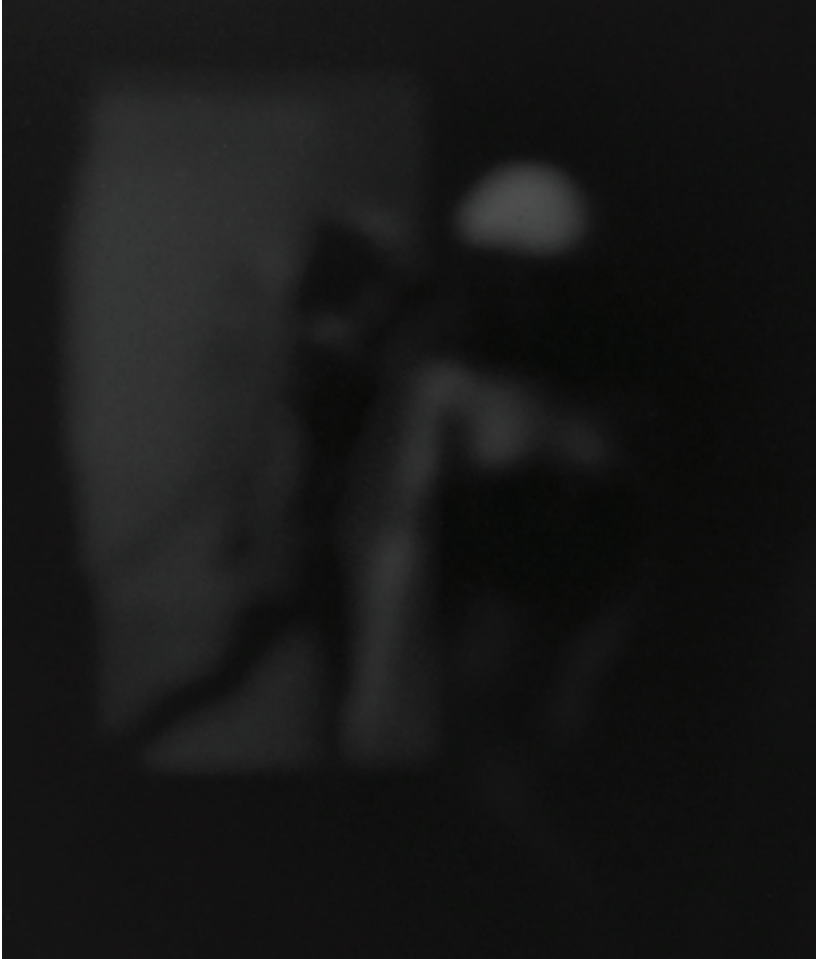

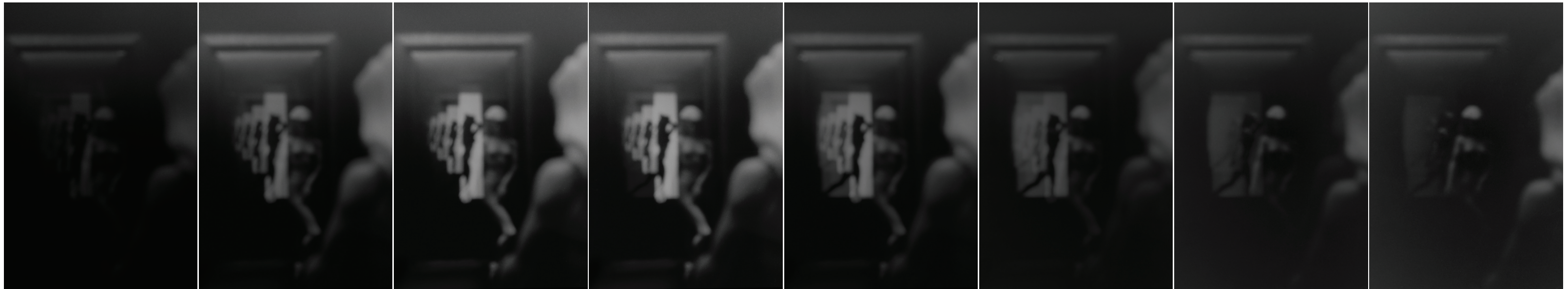

DUSK

NOON

PORTAL 1



NOON

DUSK

PORTAL 2

Cycle 1

Reflection

Initiator
Precept
Modeling
Narrative
Drawing



Cold glass, how you insert yourself



Modernity has been haunted, as we know very well, by a myth of transparency: transparency of the self to nature, of the self to others, of all selves to society, and all of this represented, if not constructed, from Jeremy Bentham to Le Corbusier, by a universal transparency of building materials, spatial penetrations, and the ubiquitous flow of air, light and physical movement.

- Jonathan Hill
 (Hill 2006, 152)

f.060

(left) Francesca Woodman

'A Woman A Mirror A Woman is a Mirror for a Man'

f.061

(right) Francesca Woodman

'A Woman A Mirror A Woman is a Mirror for a Man'

Two sets of photos by Francesca Woodman are selected in which glass has some sort of material relationship with her photographed body. Glass is, as Jonathan Hill states, the subject of a myth of transparency; it is never completely transparent (Hill 2006, 152). It is an almost-not-there divide in which we see a doubling of ourselves to varying degrees of solidity inside its thinness. Looking through glass we see a self portrait of being at once inside and outside, held and withheld.

In the first photo pairing Francesca Woodman lowers herself between layers of glass (f.060, f.061). It is almost as if she is attempting to hide, as if the transparency of the plane she holds in front is something only we are seeing through. This lowering between planes of glass creates a doubling of her body that bounces back and forth as she withdraws into its infinite depths.



Between myself and myself.

- *Sylvia Plath* from "The Other"
 (Plath & Hughes 1981, 202)

In the second pairing she is not withdrawing to hide in glass, she is on display, advancing to lean against it (f.062, f.063). These photos show a feeling out of boundaries as she pushes against the container that contains her. In the flattening of her flesh, the pressures of the almost-invisible container are revealed; it is as if she is involved in a pantomime, a feeling out of the limits of space itself. In this close altercation with glass, does she see herself faintly reflected? Is she pushing against the glass as well as her reflected doubling?

In both photo pairings there is a frame around the glass that seems to suggest the glass might be a portal, that there is the possibility of a crossing through the almost-invisible divide that the glass implies. Through glass and the frame - these are self portraits of being at once inside and outside, held and withheld.



But if I was no longer conscious of space, of place, of locus, there remained that consciousness of the space of my body, from head to toe, which was nothing else but the pain of being withheld at that very moment and in this grotesque manner.

And by whom? ... And that whoever is saying, 'Where am I?' was in reality an other, truly and corporeally an other who, in time had always wanted to consider himself opposed to my eternal and not my temporal self.

- *Antonin Artaud*

(Artaud & Hirschman 1965, 195)

f.062

(left) Francesca Woodman

'From Space², Providence, Rhode Island 1975 - 1976'

f.063

(right) Francesca Woodman

'From Space², Providence, Rhode Island 1975 - 1976'

Cycle 1

Reflection

Initiator
Precept
Modeling
Narrative
Drawing



f.064 by Author 'Withheld : Photo 01'

Title Withheld
 Date 13 March 2008
 Size (cm) 60W x 40D x 160H
 Material translucent plastic sheeting, nylon rope

Inside and outside are both intimate – they are always ready to be reversed, to exchange their hostility. If there exists a border-line surface between such an inside and outside, this surface is painful on both sides.

- *Gaston Bachelard*
 (Bachelard 1994, 217-218)

The passage, quoted left, by Gaston Bachelard seems appropriate to the doubling the body experiences in glass; could glass be considered “a border-line surface” dividing of our inside from our outside, which are “always ready to be reversed” (Bachelard 1994, 217-218)? The maquette is a sculptural translation of this divide. The body of a rope unravels as it passes from one side of the divide to the other (f.065). There is no inside or outside, the border-line surface creates only the division between sides. The amount and direction of light across the surface alters the degree of its reflectivity and transparency. With the coming and going of light, the ropes doubling appears as a distorted oiling across the plane that separates a portion of its length from the other, ghosting over its other half on the other side (f.064).

This maquette translates the previous reading of Woodman’s doubling in glass into a distorted reflection whose appearance and disappearance as light hits a transparent divide visually separates and connects the spaces on either side.

f.065
 (opposite) by Author 'Withheld : Photo Series'



Cycle 1

Reflection

*Initiator
Precept
Modeling
Narrative
Drawing*

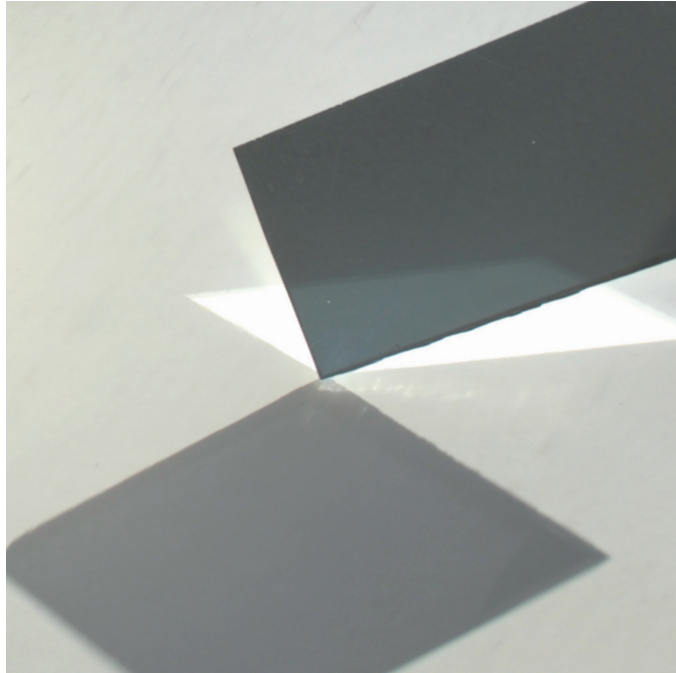

f.066 by Author 'Cycle 1 : Material, One-way Glass'

From the previous maquette a desire to work with doubling in reflection as a means to connect and separate two sides emerges. One-way glass is introduced to the minimal palate of light and the figure as constituent materials to further the investigation (f.066).

A black box is constructed with two nearly-identical figures placed on opposite ends (f.067). The act of modeling proceeds while asking: how could a glass divide between the two create a doubling that would be apprehensible on both sides?

The space between them is divided with two widely spaced one-way mirrors; a slight angling of the mirrors causes the reflections of the figures to bounce off-center between them. The two ends leading to the two glass 'portals' are open. Aiming these ends at sources of natural light during different periods of the day affects the transparency or reflectivity of the one-way glass portals between them. The figures apprehend each other to varying degrees of clarity across the spacing of the glass planes depending on how strongly the light enters either side. They each see themselves reflected; the appearance of another figure behind their reflection; and the disappearance of their reflection as the other's is seen doubling itself across the space between.

f.067

(opposite) by Author 'Cycle 1 : Model Construction'

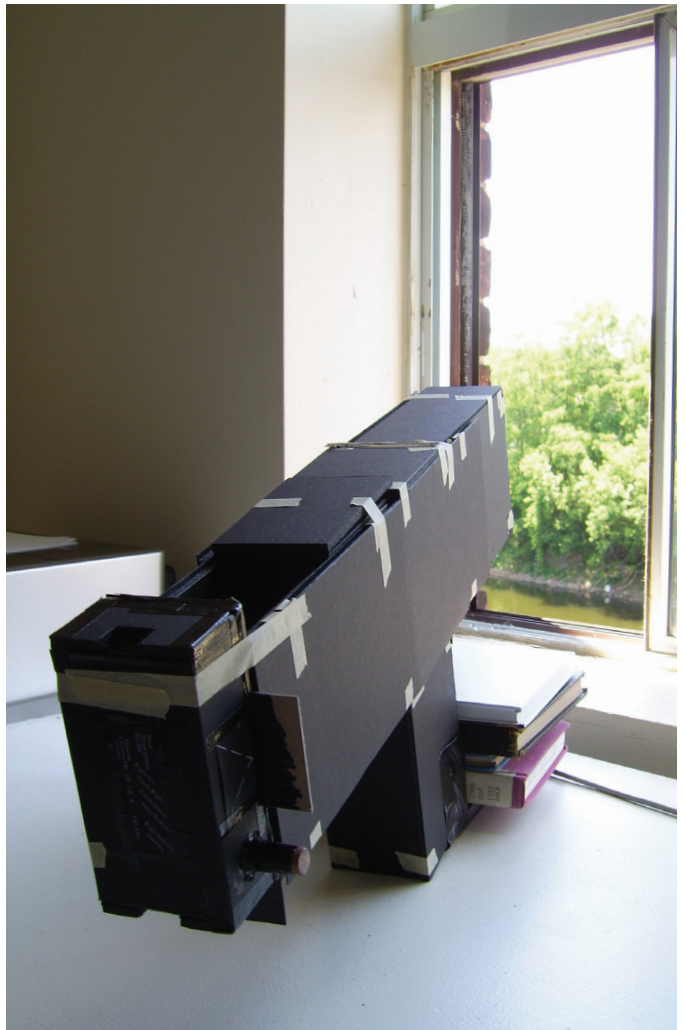
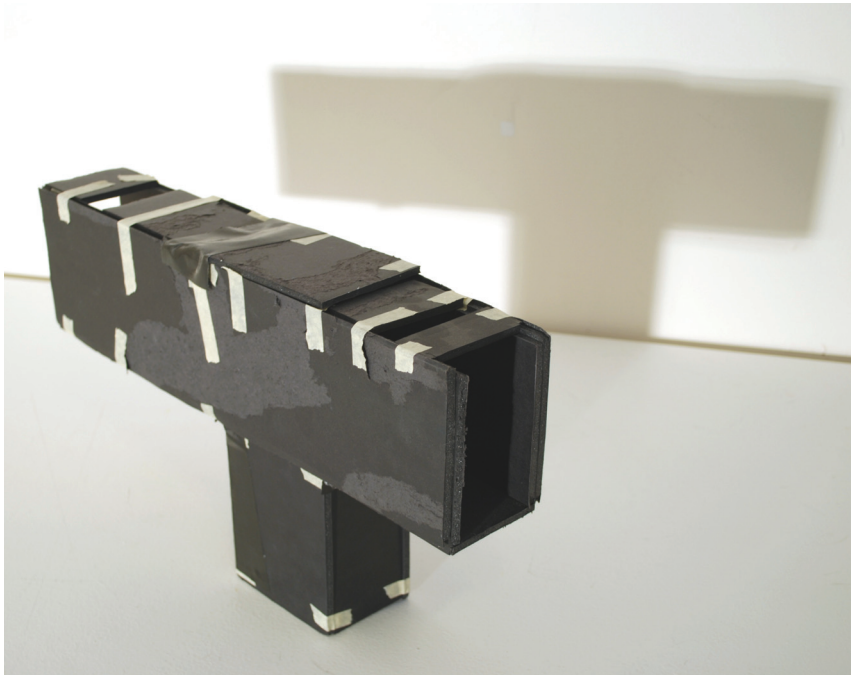

Cycle 1

Reflection

Initiator
Precept
Modeling
Narrative
Drawing

The protagonist is not the body as such but its atmospheric coming to life in relation to an always emergent environment.

- *Erin Manning*
 (Manning 2009, 121)



f.068 by Author 'Pinhole Camera'

The reflective parts of the construction were a challenge to achieving photos without seeing the camera. To address this, a pinhole camera was made as its body was easily camouflaged (f.068), however in the resulting photos reflection is not recognized as reflection; instead it might be perceived as a foggy emergence. This was deemed a happy accident as the un-detailed and un-focussed effect of the photos created a hesitant atmosphere around the reality/unreality of the event depicted.

Both openings are photographed each time the natural light entering the model significantly changed in intensity (f.069, f.070); the times of day that exhibited the most significant change, night, dawn, noon and dusk, corresponded to the most significant change in the visual play of reflection through the one-way glass. It is here that Eos's myth began to guide the narrative emerging; since these are also key times in her diurnal cycle, the most cogent of the photo pairings were mapped to these specific diurnal times and a narrative coaxed out (f.071):

NIGHT - Only darkness is visible.

DAWN - Dawn personified (Hermera) sees her own reflection. At the same time, Dusk personified (Hespera) sees the fractured reflection of the Hermera, the figure behind the opposing portal,



f.069

by Author 'Cycle 2 : Pinhole Photos, different light exposures in Portal 1'



f.070

by Author 'Cycle 2 : Pinhole Photos, different light exposures in Portal 2'

emerge behind her own reflection to gradually become brighter.
 NOON - Daylight enters evenly into both rooms causing the glass between them to allow a clear view through it: the two figures become faintly visible to each other as they actually are.
 DUSK - Hespera sees only her own reflection. At the same time, Hermera sees the fractured reflection of Hespera, the figure behind the opposing portal, emerge behind her own reflection to gradually become brighter and then fade into night.

From the matching of the paired photos to possible 'events,' a type of film strip emerges. The next pages elaborate on how the photos pairings were arranged in time as others were taken to create a gradation of experience between them (f.072, f.073).

f.071

by Author 'Cycle 2 : Key Pairing of Stills'

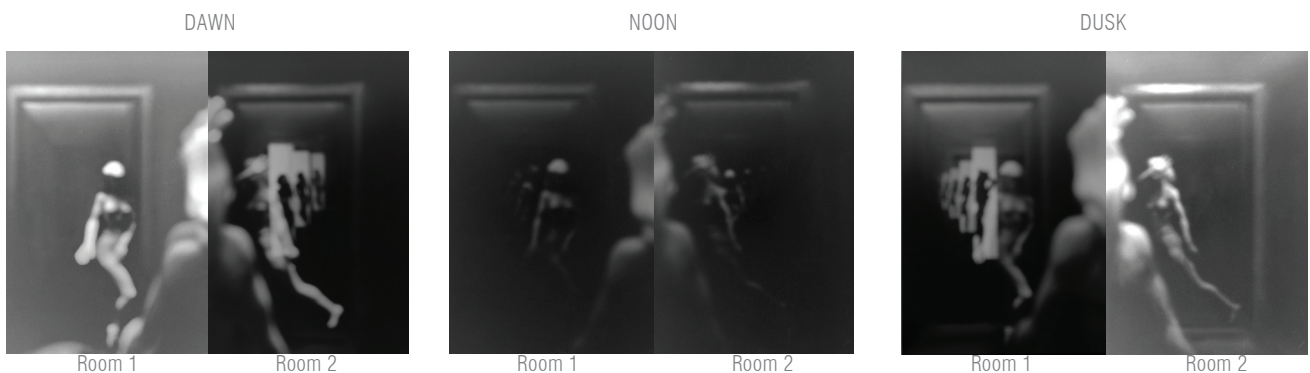

Cycle 1

Reflection

Initiator
Precept
Modeling
Narrative
Drawing

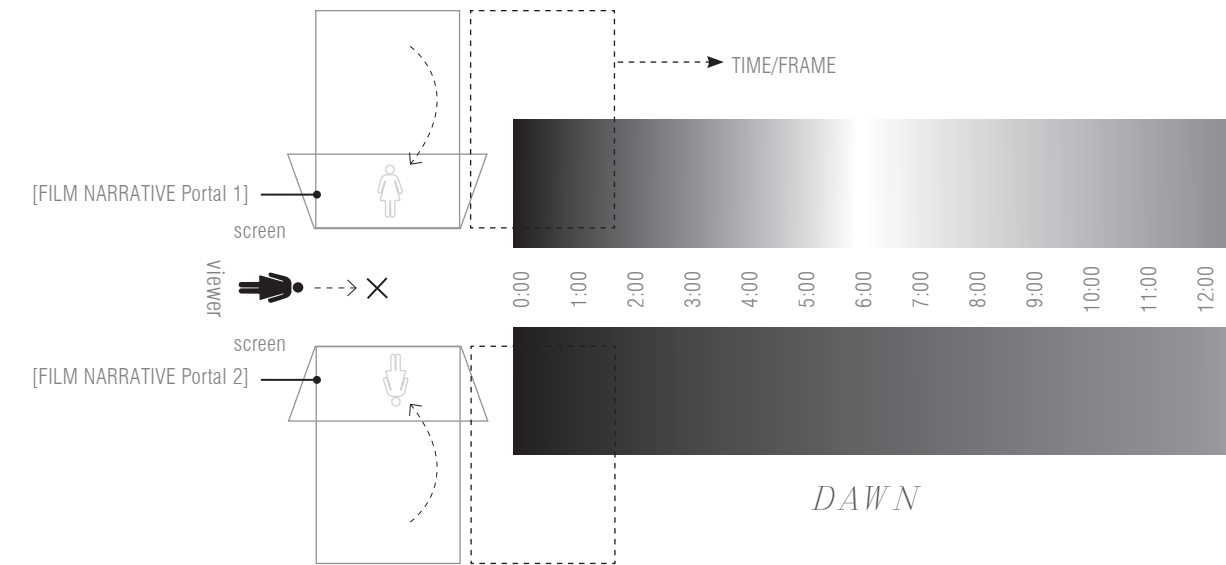

f.072

by Author 'Cycle 1 : Diagram of Light in Time through Construction'

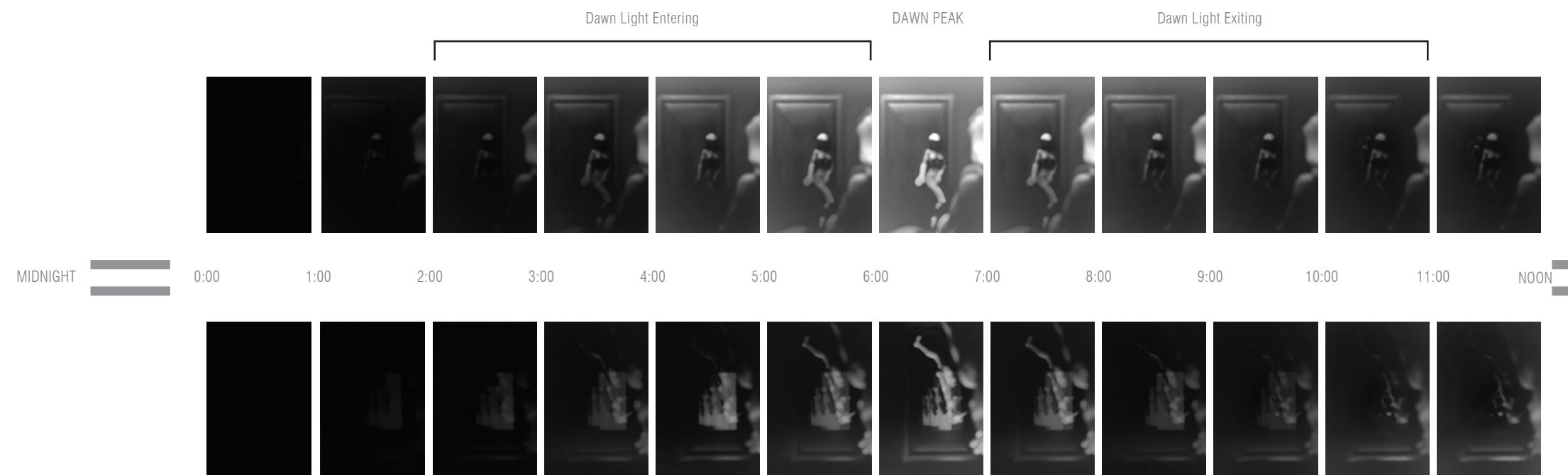

f.073

by Author 'Cycle 1 : Film Narrative in Stills'

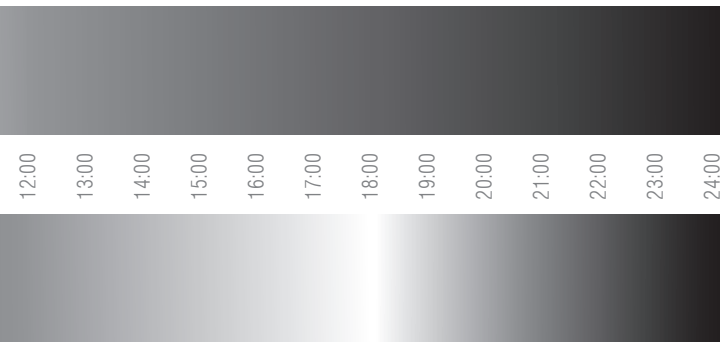

DUSK

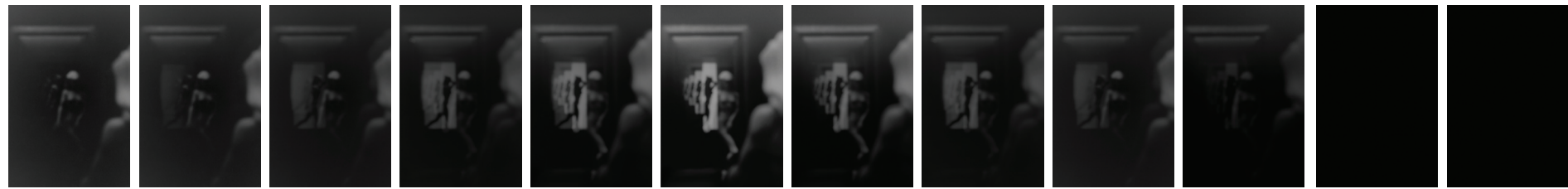

12:00 13:00 14:00 15:00 16:00 17:00 18:00 19:00 20:00 21:00 22:00 23:00 24:00

MIDNIGHT

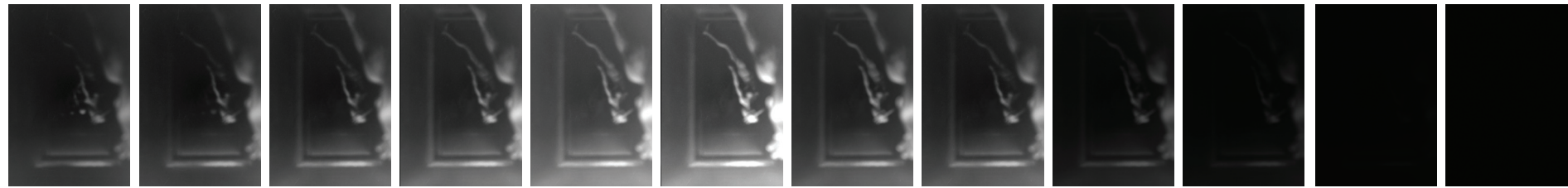

Dusk Light Entering DUSK PEAK Dusk Light Exiting

Cycle 1

Reflection

Initiator
Precept
Modeling
Narrative
Drawing

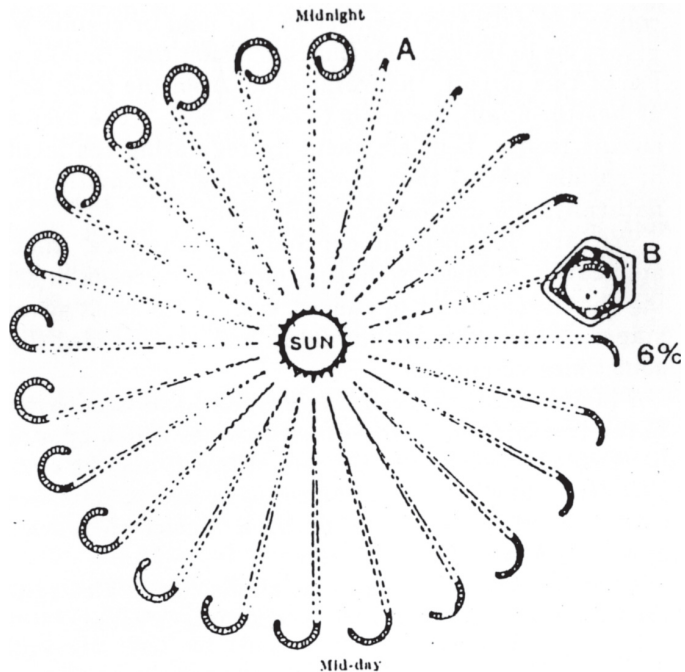

f.074 Georges Lakhovsky 'Formation of Primordial Cells'

"The diagram is not content driven - It operates at the interstices of composition where the virtual is felt as a force of becoming."

- Erin Manning
 (Manning 2009, 124)

Inspired by Georges Lakhovsky's diagram in which the formation of primordial cells is depicted as a transformative process contingent on the diurnal cycle (f.074), the first drawing places the model produced into this very durational context (f.075).

The following drawings (f.076, f.077, f.078) are mappings at the key moments in this cycle (Dawn, Noon, and Dusk), of the reflected doublings that are occurring between the two bodies and the glass that delimits the space between them. The drawings trace the doublings as they move across and past the glass portals that divide the two sides from each other. While the two bodies never share the same room, their doublings mingle together in the space between.

The lines of trajectory that is traced is akin to the rope's passing through the divide in the initial maquette (f.065) that started this design exploration; the piece is an imaginative translation of Woodman's glass box (f.062) and what is occurring there.

f.075

(opposite) by Author 'Cycle 1 : Construction in Time'

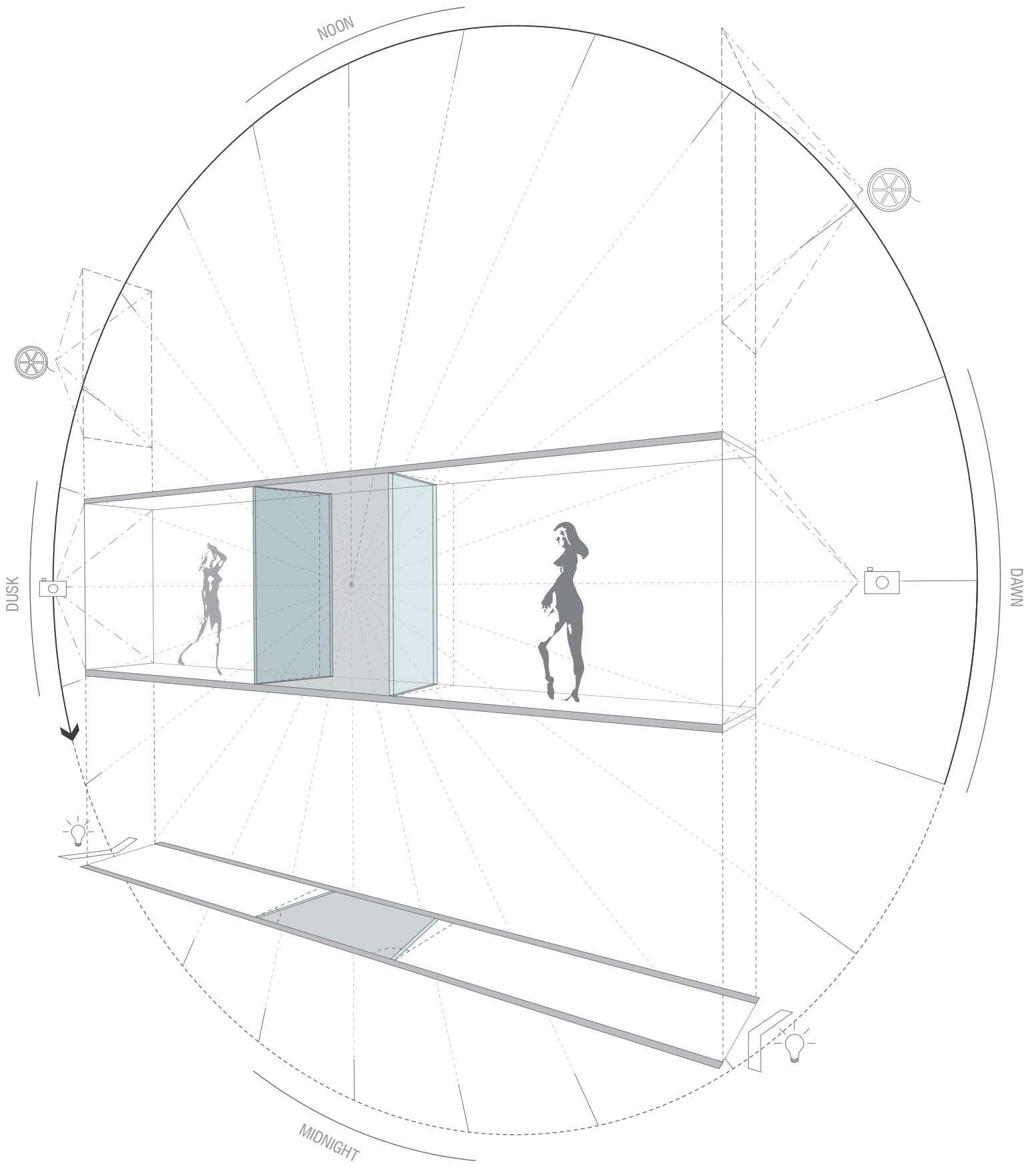

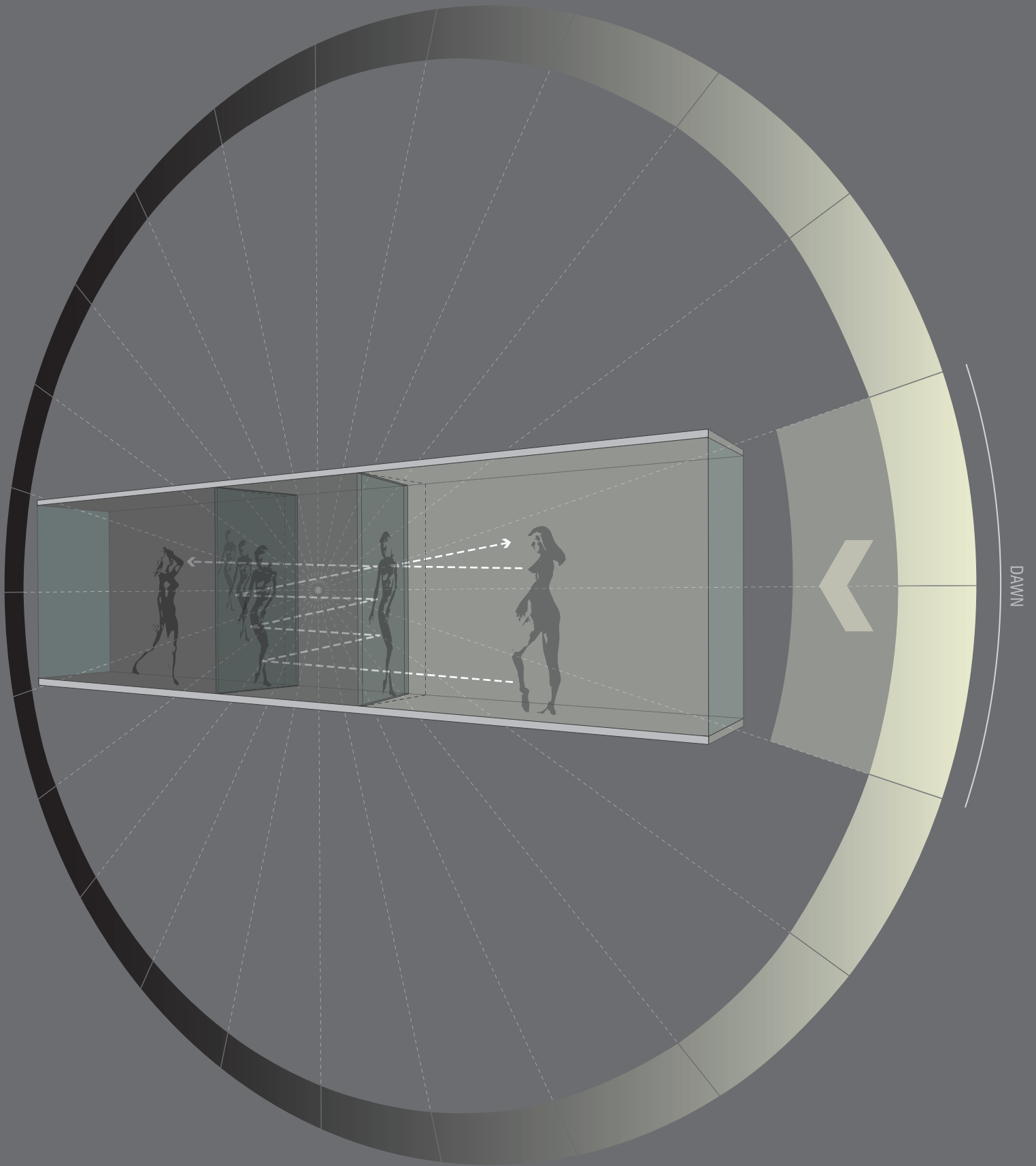

f.076

by Author 'Cycle 1 : Doubling at Dawn'

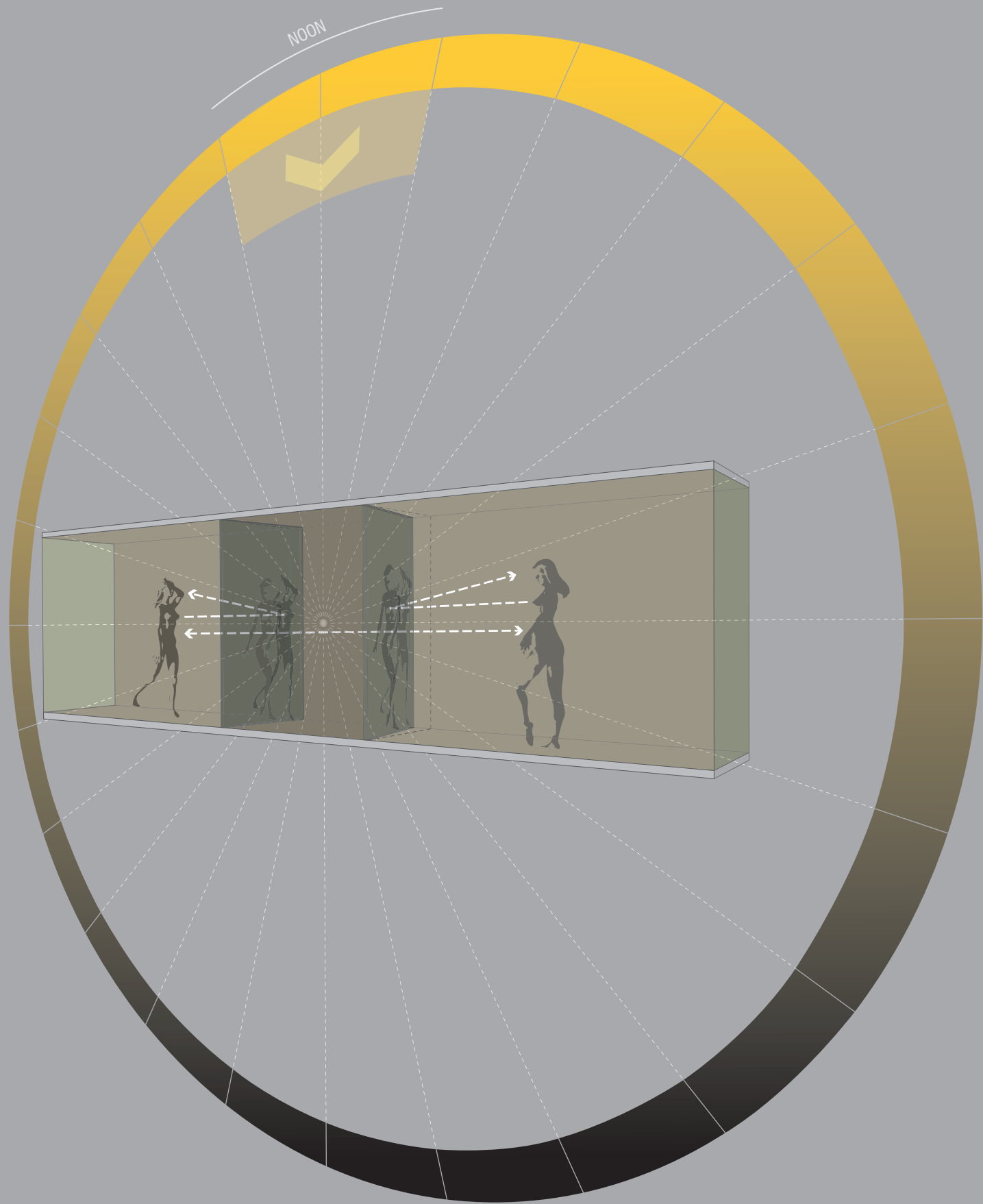

f.077
by Author 'Cycle 1 : Doubling at Noon'

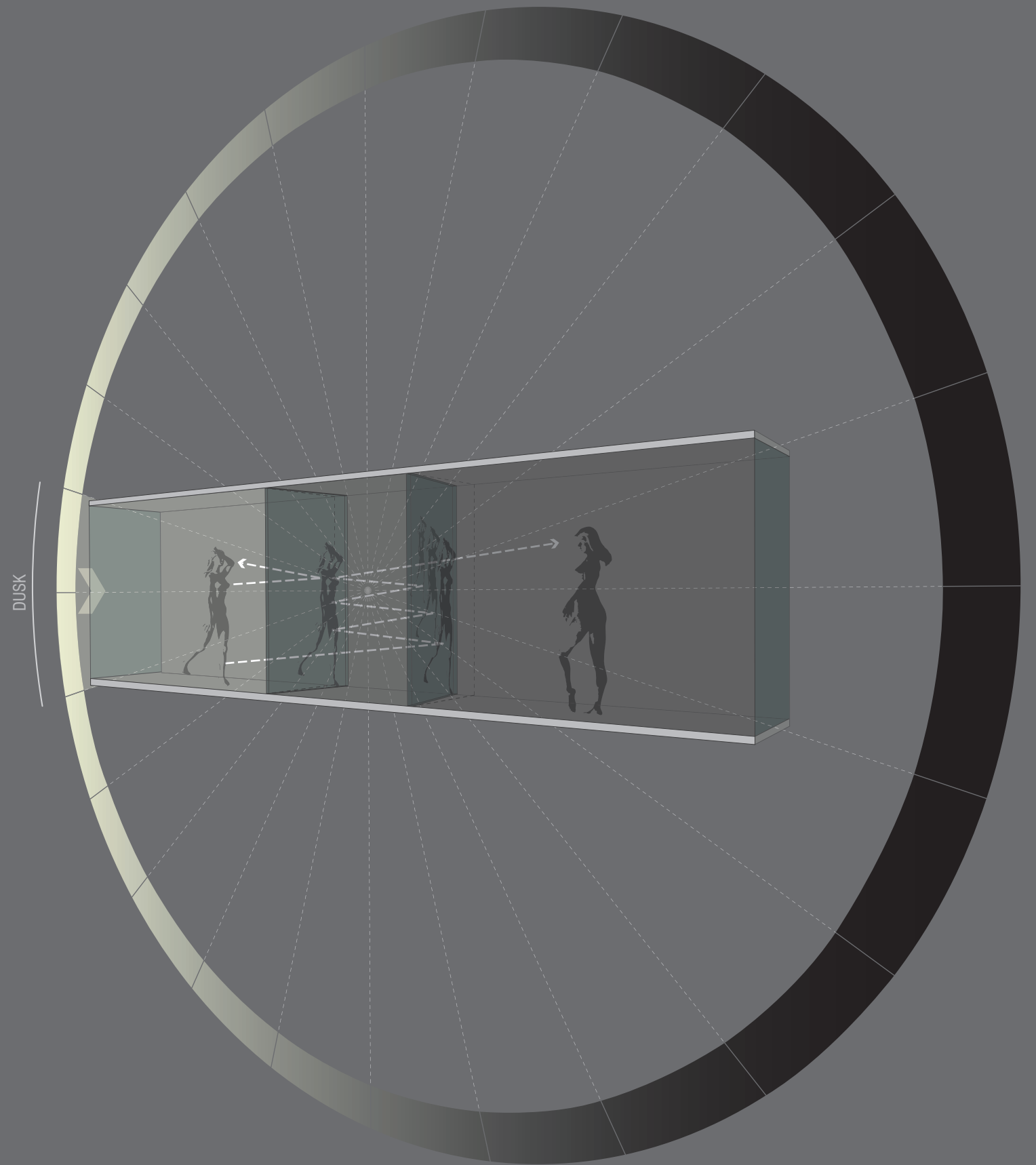

f.078
by Author 'Cycle 1 : Doubling at Dusk'

Cycle 2

Shadow



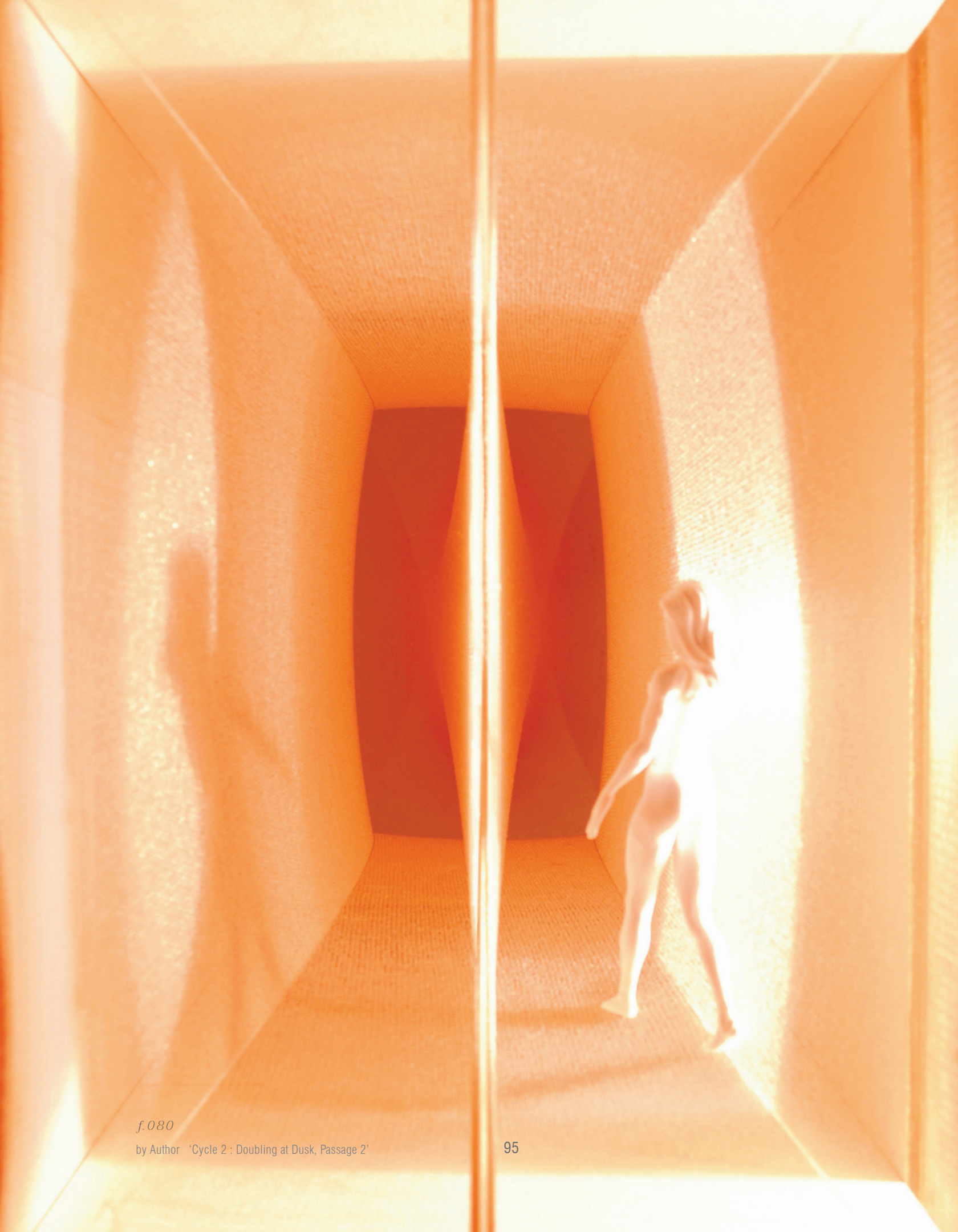

f.080

by Author 'Cycle 2 : Doubling at Dusk, Passage 2'

Cycle 2

Shadow

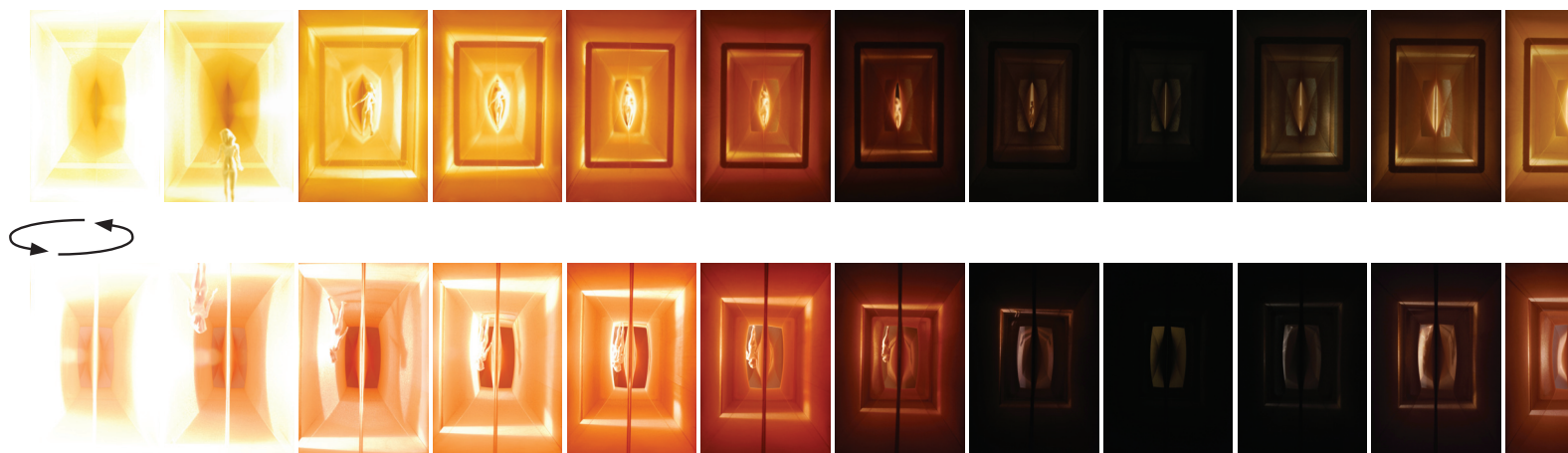

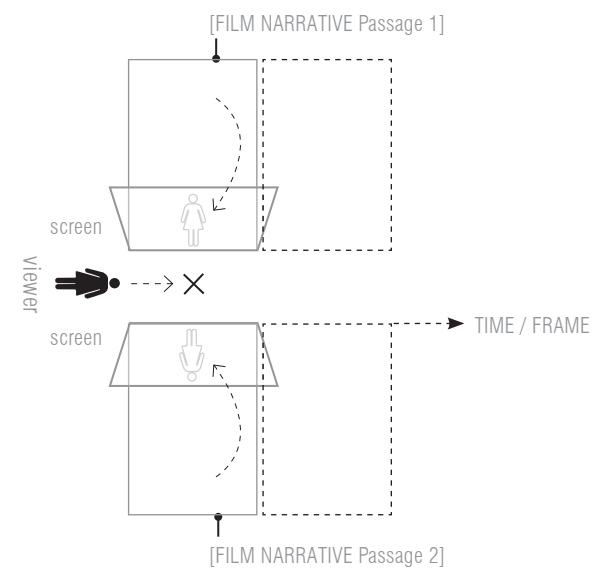

f.081 by Author 'Spatial Arrangement of Video Projection'

SHADOW: the PASSAGE

SYNOPSIS Eos advances and recedes as she travels the arc of heaven. During this stage Hermera and Hespera enter from opposite ends of the horizon into doubled openings to the passage through the heavens. The passage folds through itself creating an overlap of occupation that holds their bodies separate from each other. As they advance to the common apex, each perceives the other as a ghosted presence that splits and converges across layers of transparency - carried as if on a breath of wind into the overlapping passage beside. Arriving concurrently in the blaze of noon, they pass each other blindly and begin their exit along the path the others' doubling foreshadowed.

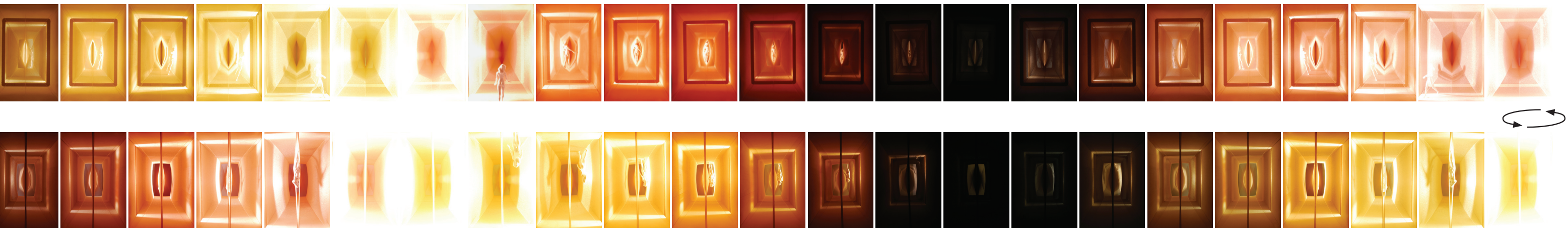

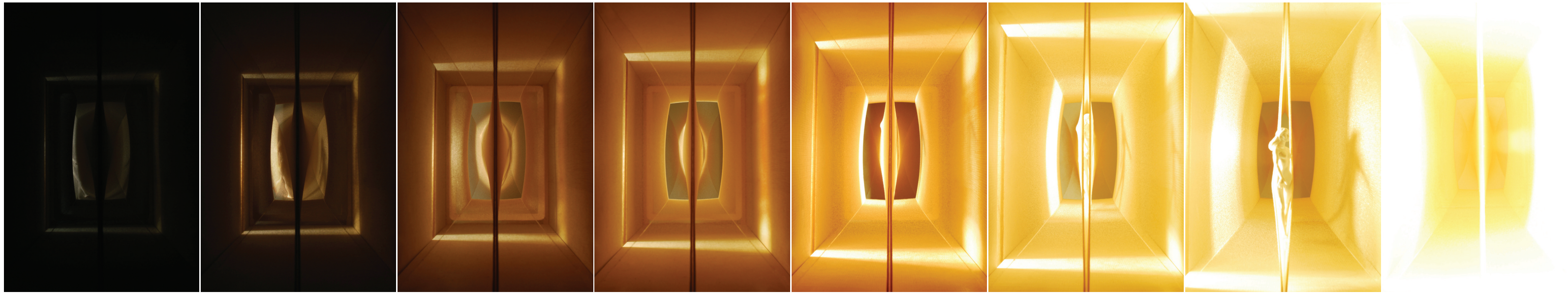

DAWN

NOON

PASSAGE 2

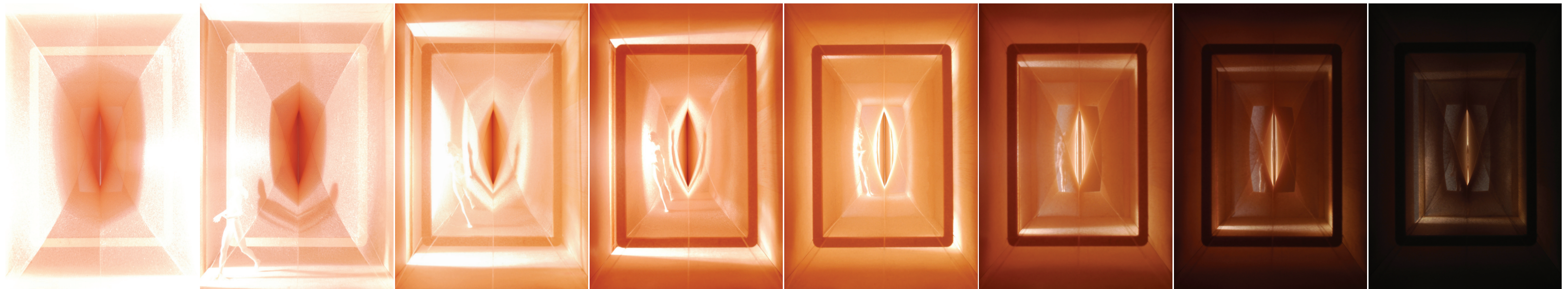

NOON

DAWN

PASSAGE 1

Night relents as heaven drains its inky capillary.
From dilating polar wells
emergent bodies flame,
yawning contagious,
as flickering occlusions
spread across adjacencies,
to pulse through the lungs of time.

Then the flare,
illuminate syncope where Helios is hoisted,
crowned with a sharp radiance.

In a blind crossing of paths,
Dusk turns them to throw sparks at the horizon.
By dying ember the bodies recede,
as their haunted halos,
umbilical as seedlings through the earth,
coil against the darkening sheets of nebulous night.

f.084

by Author 'Cycle 2 : Doubling, Detail'

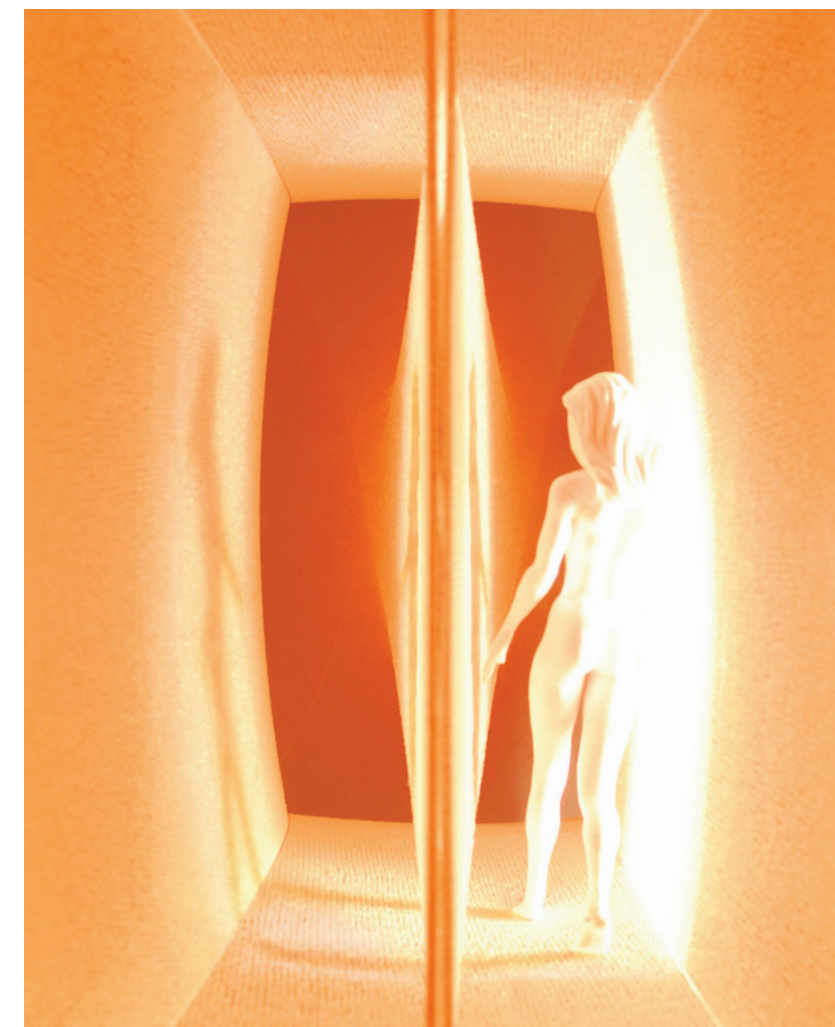
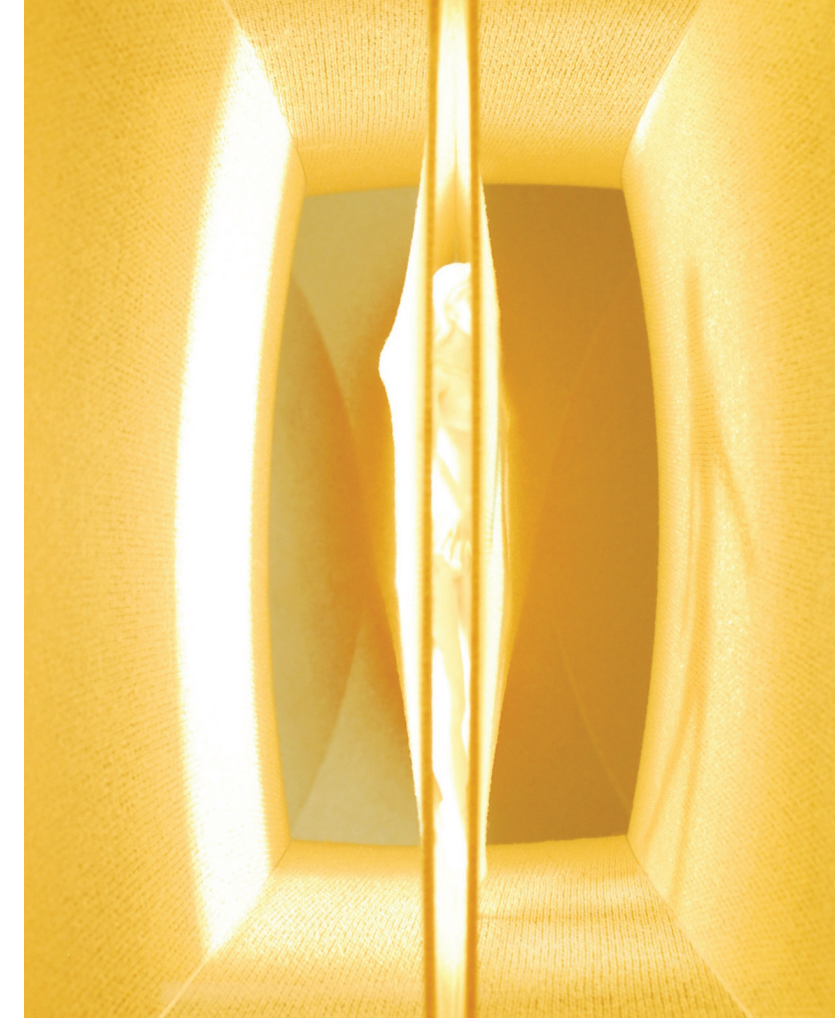

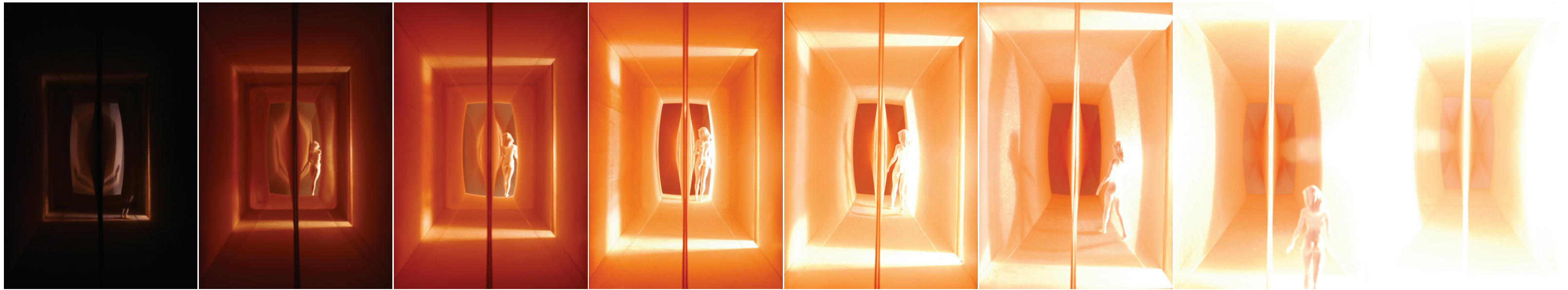

DUSK

NOON

PASSAGE 2

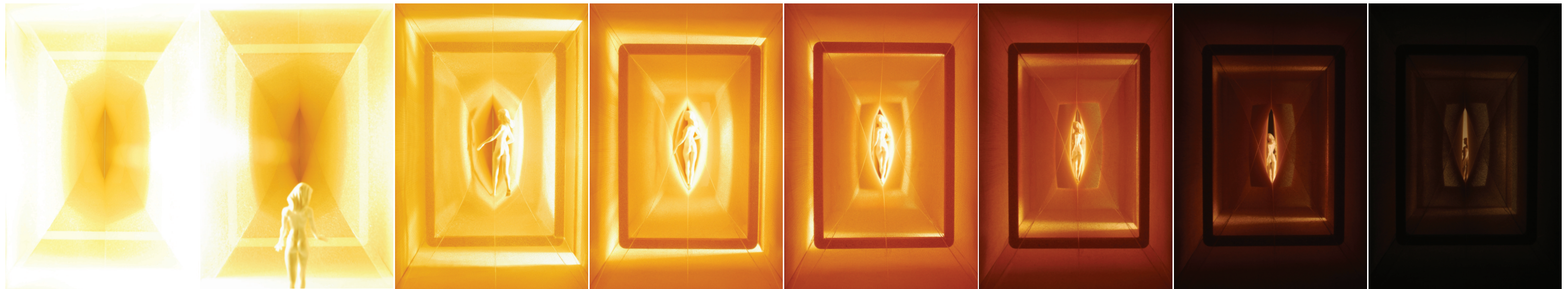

NOON

DUSK

PASSAGE 1

Cycle 2

Shadow

Initiator
Precept
Modeling
Narrative
Drawing



These photos by Francesca Woodman show her body attempting to join into a meaningful relationship with the flesh of the world. This desired relationship is physical. She uses the force available to her own flesh and burrows (f.087), burns (f.088) and sweats (f.089) herself into an extreme and intimate proximity with the matter surrounding her.

The doubling in f.087 is a rough negative of the smooth body that grows from its feet. In fact, all the depicted doublings seem to stretch out from her body, either from her feet (f.087, f.088) or torso (f.086, f.089), to embed themselves in her surroundings, they are always at once in contact with her body and the matter external to it. This mutual contact seems to join seemingly disparate properties such as the negative and positive in f.086 and f.087, and the darkness of the doubling with the light-

f.086

(left) Francesca Woodman

'It Must Be Time For Lunch Now, New York, 1979'

f.087

(right) Francesca Woodman

'From Angel Series, Italy, May 1977 - August 1978'



ness of the body's flesh.

In f.086 matter leaves its impression on her, and in f.087, she leaves her impression on it. There is a reciprocal doubling in these two photos in which the impression of body on matter and matter on body is a 'medium of exchange' through which a mutual touching or 'bond' forms between the two sides defined as body and environment.

These photos might be read as an attempt to blur the line between these two distinct 'sides' of body and external matter by crossing or overlapping them; "a relation of superposition: of two laps overlapping-encroaching upon, slipping or crossing over into each other-so that portions of each 'wind up' on the other's side." (Cataldi 1993, 69)



f.088

(left) Francesca Woodman 'Providence, Rhode Island, 1976'

f.089

(right) Francesca Woodman 'New York, 1979'

Cycle 2

Shadow

Initiator
Precept 1
Modeling
Narrative
Drawing



f.090 (top) by Author 'Through & Through 1 : Film Still'

f.091 (bottom) Lisa Robinson 'Departed' - detail

Title	Through & Through 1
Date	26 Feb 2008
Size	n/a
Technology	digital video
Material	human body, snow

This video was produced as translation of the impression of the body's action on the environment read in Woodman's works - of the confluence between the negative and positive that occurs in the moment of contact. The piece focuses on the footprint (f.090, f.091); the material dynamics of the body's walk as a doubling into the matter of the horizon.

The horizon clearly divides heaven from earth; it is a consistent and ever present dichotomy that our very action of walking upon disturbs. The doubling of the body's action into footprint is shown in a slow motion film as a study of the exchange between the warmth of some foot and the biting accumulation of snow (f.091).

f.092

(opposite) by Author 'Through & Through 1 : Film in Stills'

Stretched bared + broad,
the body's length is pillowed,
seduced by weathered wind
to curl into a shape.

Beneath the sole of your foot
warmth engulfs lesser warmth,
a heat sink for the
spent airs of your body.

This could be balance gathering
all your limbs to one place: the horizon,
a history of collisions
carried through the earth.

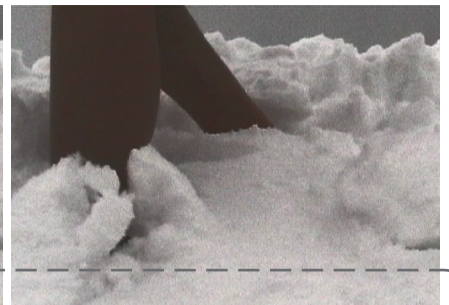

Cycle 2

Shadow

Initiator
Precept 2
Modeling
Narrative
Drawing

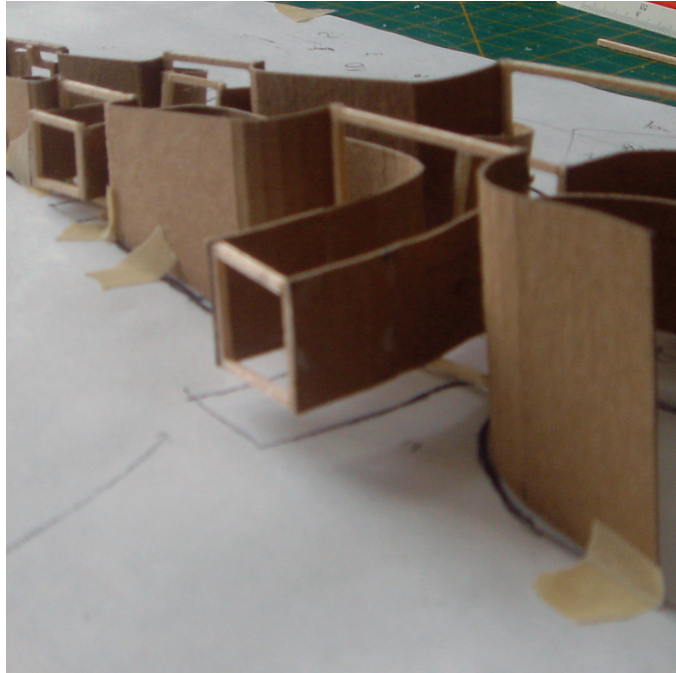

f.093 by Author 'Through & Through 2 : Model Photo'

Title	Through & Through 2
Date	10 Feb 2009
Size	n/a, & (cm) 28L x 6D x 13H
Technology	CAD and hand constructions
Material	card stock, balsa wood

The dynamics of the footstep inspire a further sculptural exploration (f.093). The footstep is a force carried through the strata of the earth as it pushes back. The sculpture is an exploration of the reciprocity of matter pushing against and through itself.

Like the air that rips through the body of the river the strata of the sculpture's material telescope through each other (f.094). For every downward push there is an upward that pushes back and around it. The openings created by these pushings through seem to frame and re-frame each other, the resulting form of which seems to resonate with the 'overlap' read into Woodman's works.

f.094
 (opposite) by Author 'Through & Through 2 : Model Photos'

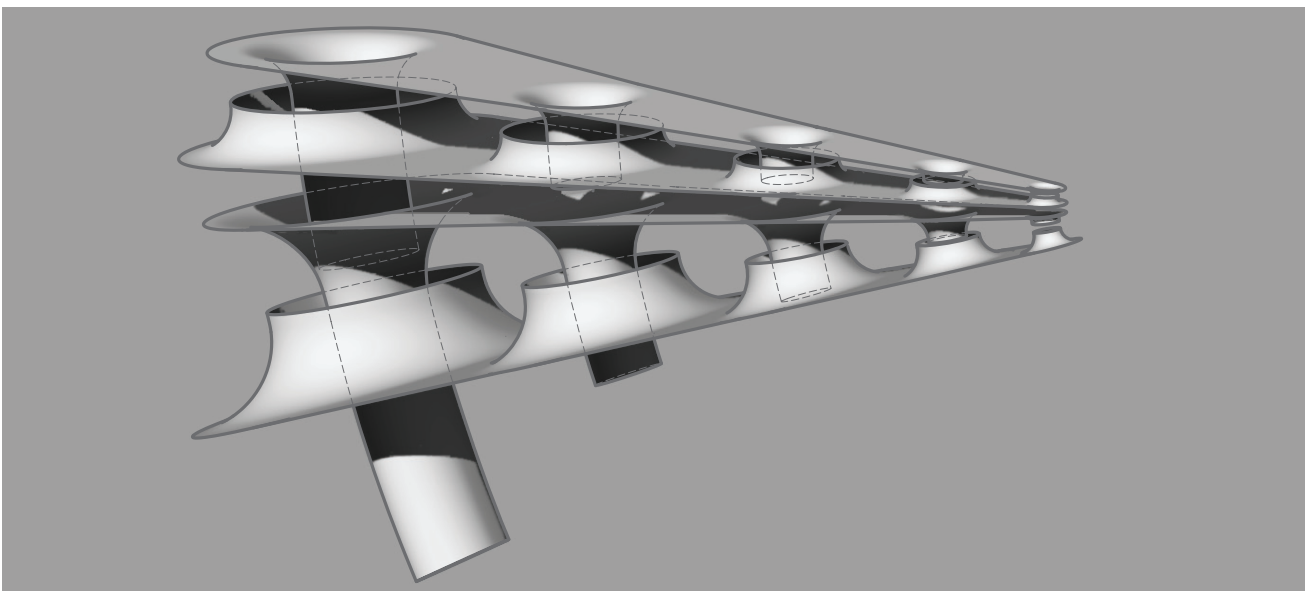
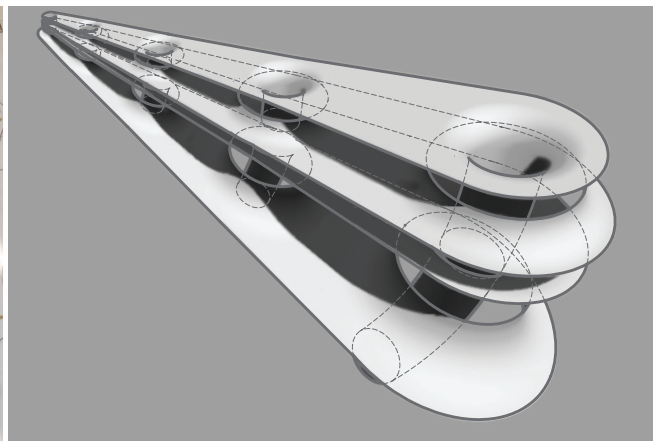
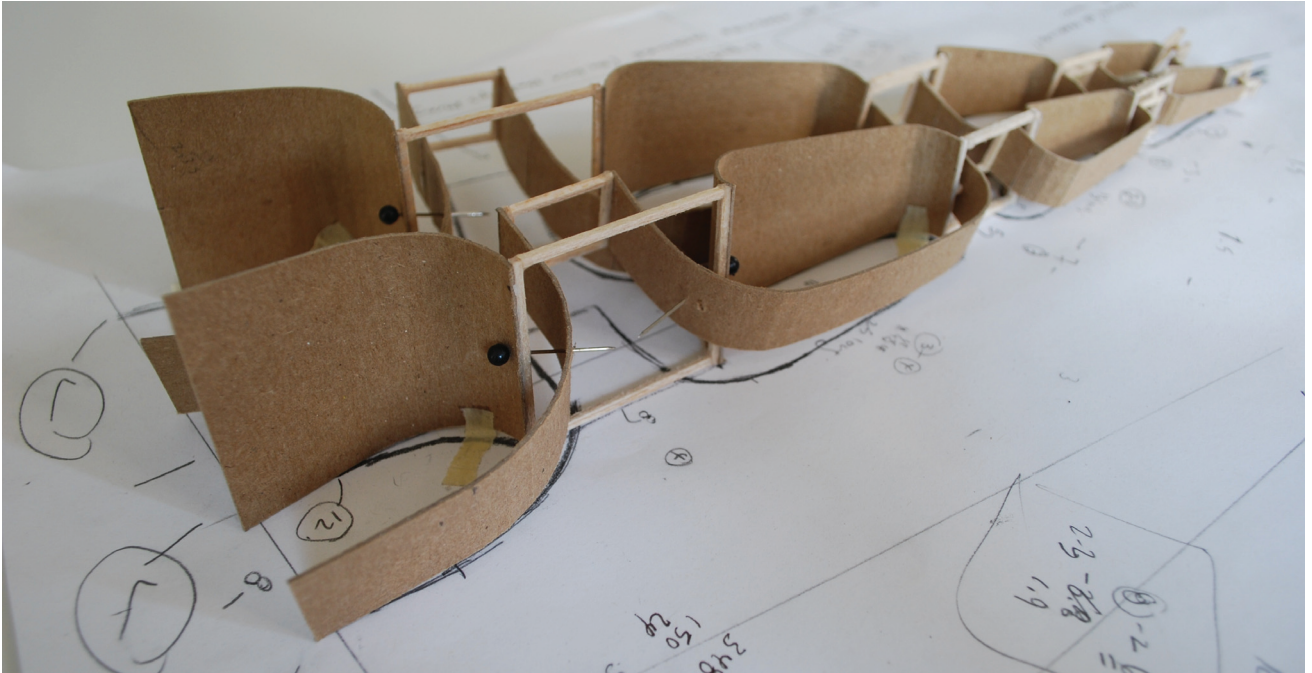

Cycle 2

Shadow

Initiator
Precept
Modeling
Narrative
Drawing

The unique range of elasticities of
 Impressionable stretching, not yet texture.

- *Shusaku Arakawa*
 (Arakawa 1988, 95)

But is he who opens a door the same as he who closes it the
 same being? ... there are two 'beings' in a door, that a door
 awakens in us a two-way dream, that is doubly symbolical.

- *Gaston Bachelard*
 (Bachelard 1994, 224)

f.096

(opposite) by Author 'Cycle 2 : Model Construction'



f.095

by Author 'Cycle 2 : Material, Translucent Stretch Textile'

From the previous maquette translation of Woodman's work, an
 interest in the overlap as a point of contact and means of estab-
 lishing a reciprocal relationship begins to emerge.

A translucent stretch textile is chosen as the primary material of
 the next construction for its ability to create various degrees of
 transparency through layering. The textile's weave holds both
 shadow and light while its tone and tensile characteristics are
 sympathetic to the characteristics of flesh and touch (f.095).

The process of modeling proceeded with this question in mind: if
 as Bachelard states, "there are two 'beings' in a door" (Bachel-
 ard 1994, 224; see left for full quote), how could one opening be
 manipulated using overlap to create two points of entry between
 which a doubling could manifest?

Various sized frames are used to set the tensions within the
 construction that allow for the textile to be pulled through it-
 self. This creates the superimposition, or overlap, of two pas-
 sages whose respective openings contain or frame one another
 (f.096). As light cuts through its section, the shadows of the
 two figures moving through the passages are pushed through
 the layered walls to various effects.

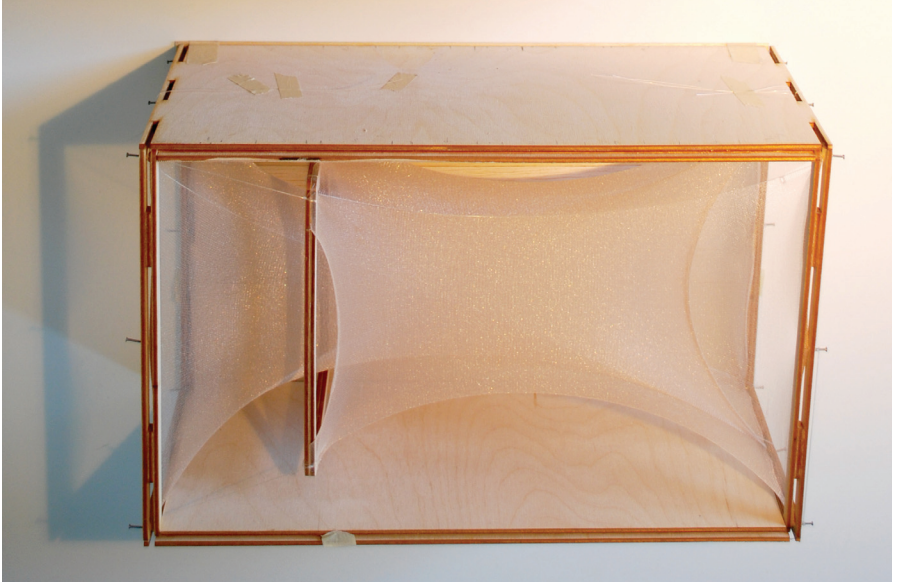
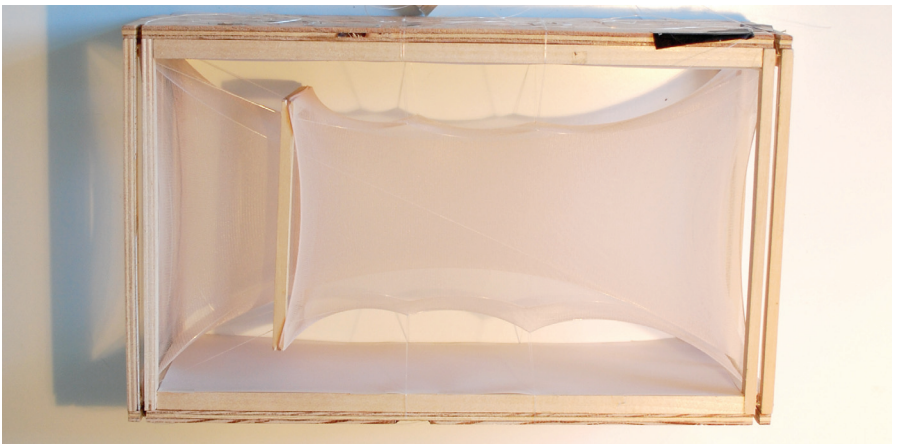
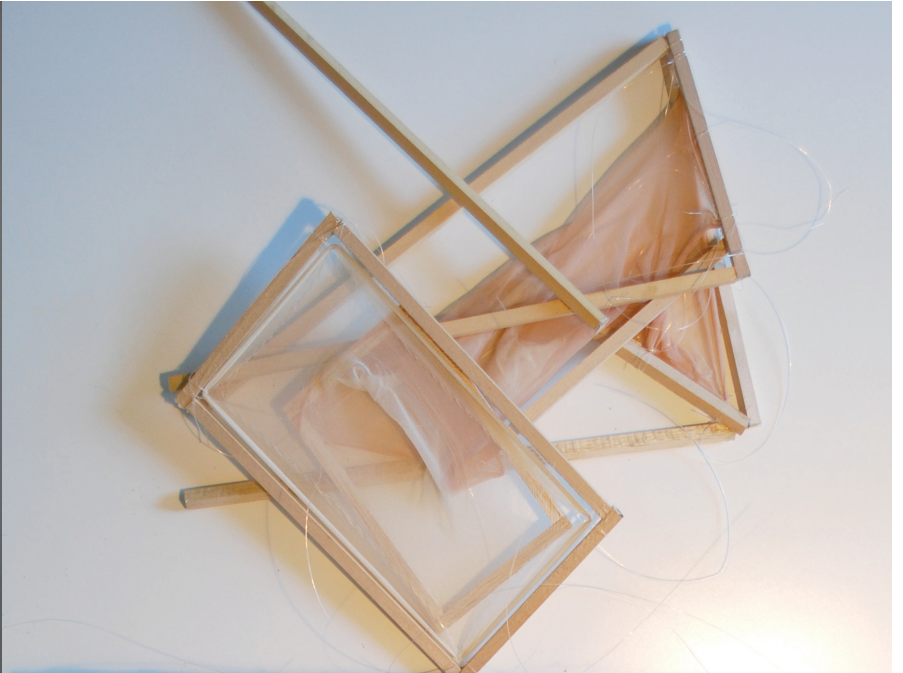

Cycle 2

Shadow

*Initiator
Precept
Modeling
Narrative
Drawing*

THE CORRIDOR - *William Bronk* (Bronk 1997, 212)

You, what I own, I still stay with you
But now, not owned: any place I go,
and it seems a going, keeps me here, unowned,
unowning, nowhere going. The landscape moves
but all its moving is immobilely scintillant.

There is a corridor I live in: walls
on the side is there were walls. There are no walls;
I am the corridor, thin skin the walls.

Once, it seemed not so: I went where I went
and pulled the places back, fondled them,
founded walls and left them, drifted out.

Space is empty now apart from me.
I feel its sparseness, never to change;
I feel the deprivation, the narrowing,
the down-reduction, focus, concentrate.

I meet and meet, over and over again
the same terrible knowledge with the same
wonder, the same refreshment as I never met
before, the met-unmet, though we know we met
and the meeting is always, never always, the same.

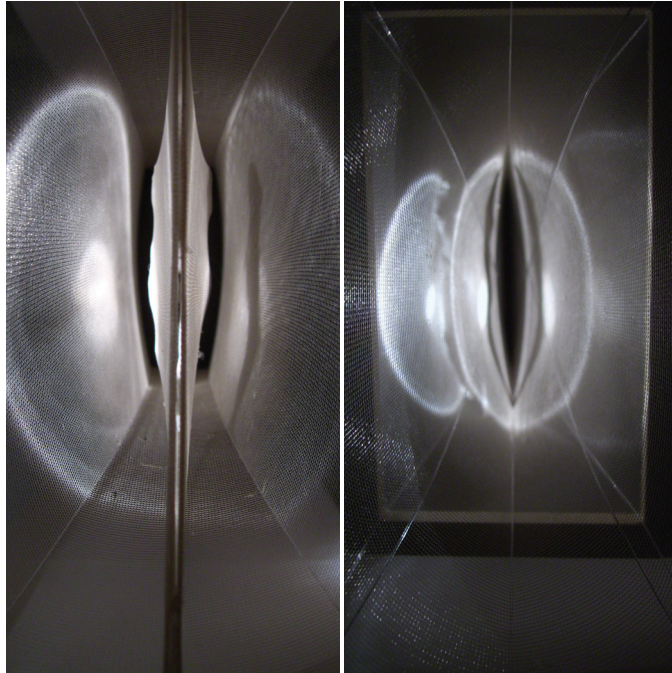

f.097 by Author 'Cycle 2 : Test Photos of Internal Lighting'

Two figures are moved through opposite openings in the model that lead down overlapping passages. A moveable slit in the side of the model follows their path so that each step of their journey becomes an illuminated section in which their shadows project through its many layers (f.097). These doublings stretch out from the figures to bleed through to the overlapping passage beside. As such, these doublings occupy the adjacent passage the other figure is scripted to enter; these doublings foreshadow the route the other figure is about to take.

For each 'step' multiple exposures are photographed resulting in a series of stills that bath the figures moving towards and away from the camera in a gradation from blazing light through to complete darkness (f.101). This results in an overwhelming number of photographs and possibilities for what the narrative tying these movements together might be.

Here, Eos' myth steps in to help shape the narrative. As Eos' movement through the heavens is explicitly linked to the waxing and waning of light, the stills are arranged in arrays that link the steady movement of the figures in the model to the steady gradient of advancing and receding light (f.102).

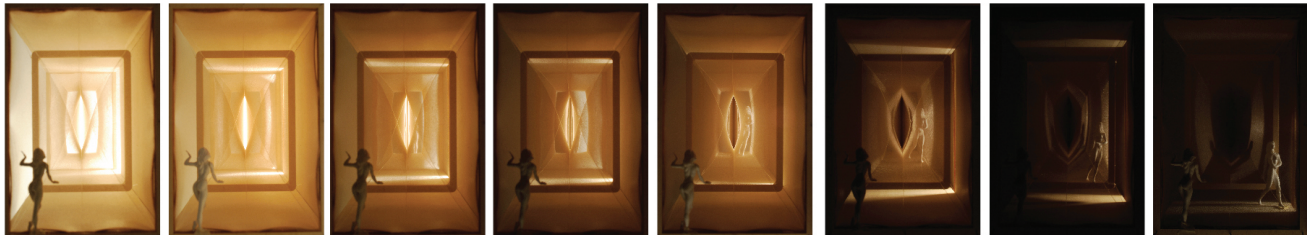

f.098

by Author 'Cycle 2 : Test Photos, Passage 1 light advancing'

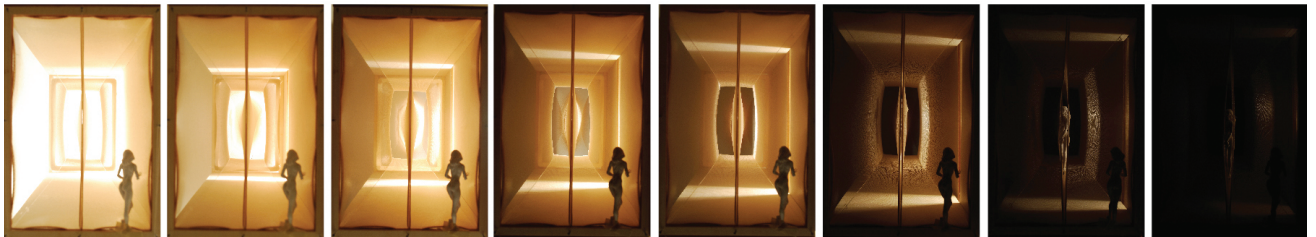

f.099

by Author 'Cycle 2 : Test Photos, Passage 2 light receding'

These photo arrays are then scripted to key moments of diurnal illumination, while the light accompanying each figure is tinted yellow vs rose, creating a slight differentiation to emphasize the moment the two figures cross each other to move into the 'overlap' (f.103).

From out of the darkness of night, dawn brightens the figures as they advance towards each other from opposite ends. As they reach noon, they enter into the only 'common space' of the model. Here, under intense illumination, they pass each other blindly and begin their departure of the heavens. Heading away from each other, they leave with the light through the overlapping passage the other figure foreshadowed on their approach. The cycle begins again.

f.100

by Author 'Cycle 2 : Key Pairing of Stills'

DAWN - figure and light advancing

NOON

DUSK - figure and light receding

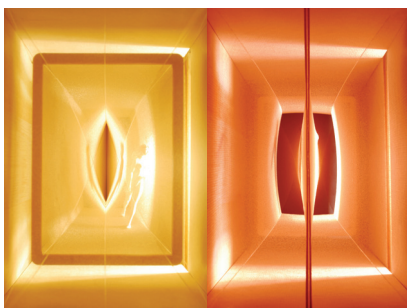

Passage 1

Passage 2



Passage 1

Passage 2

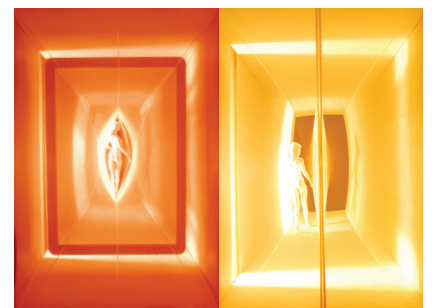

Passage 1

Passage 2

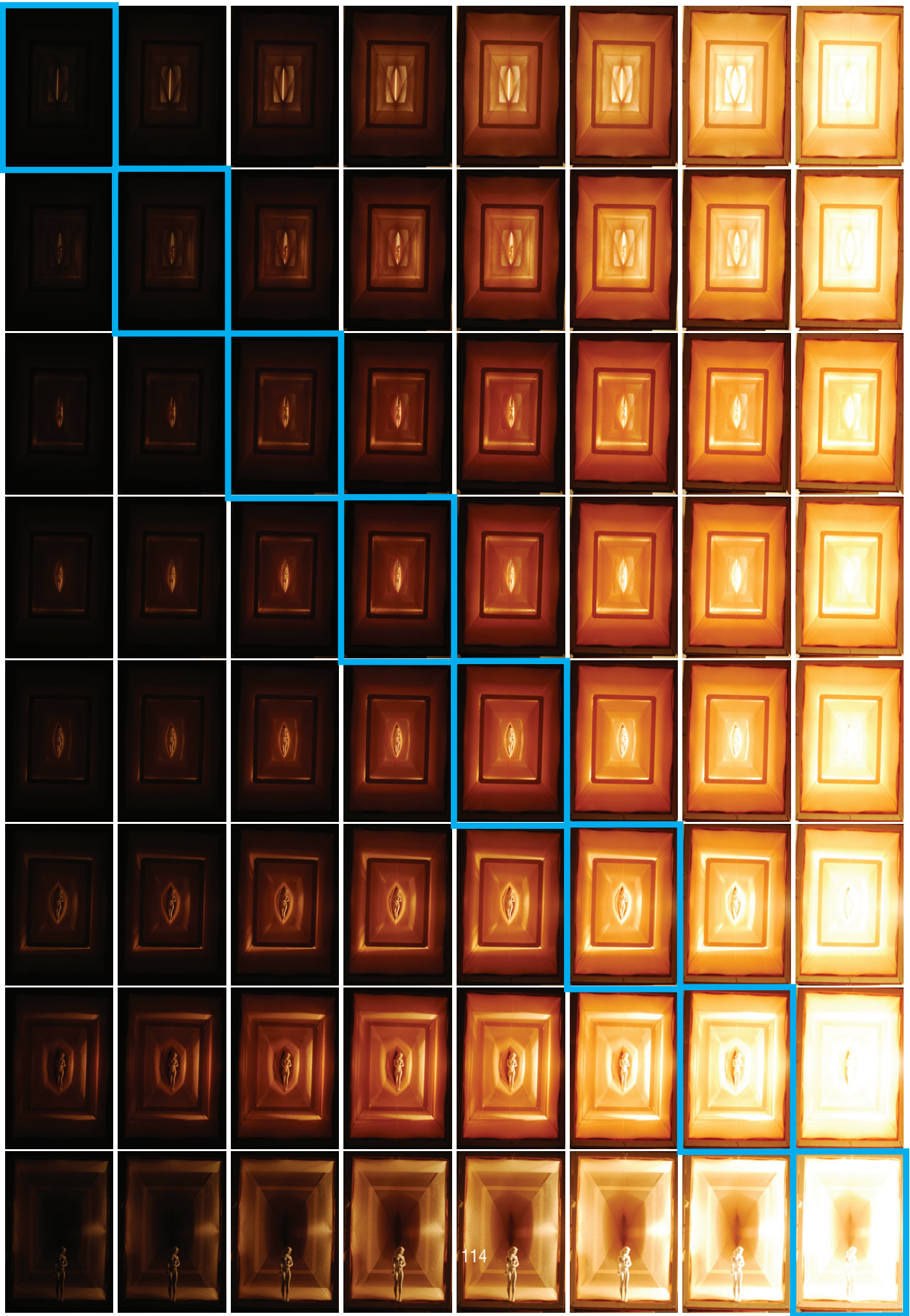

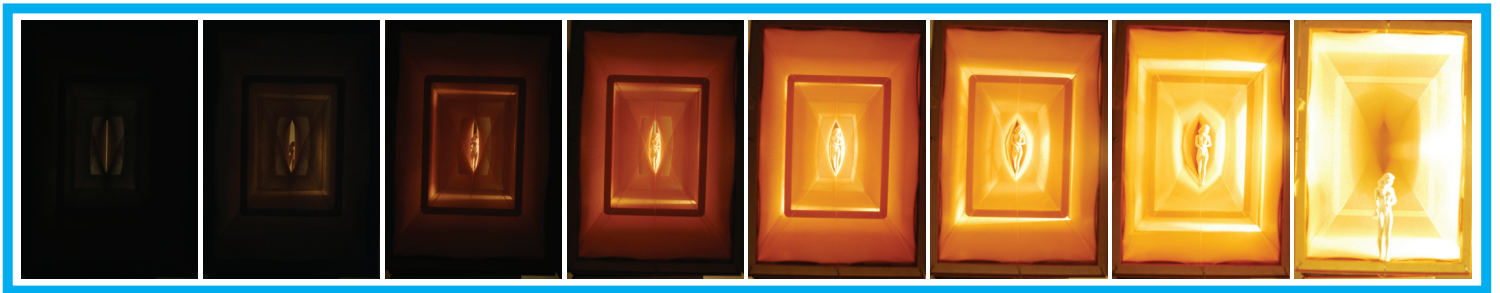

f.101

(left) by Author 'Cycle 2 : Photo Array, Passage 1'

f.102

(right) by Author

'Cycle 2 : Selected Series, light & figure advancing, Passage 1'

Cycle 2

Shadow

Initiator
Precept
Modeling
Narrative
Drawing

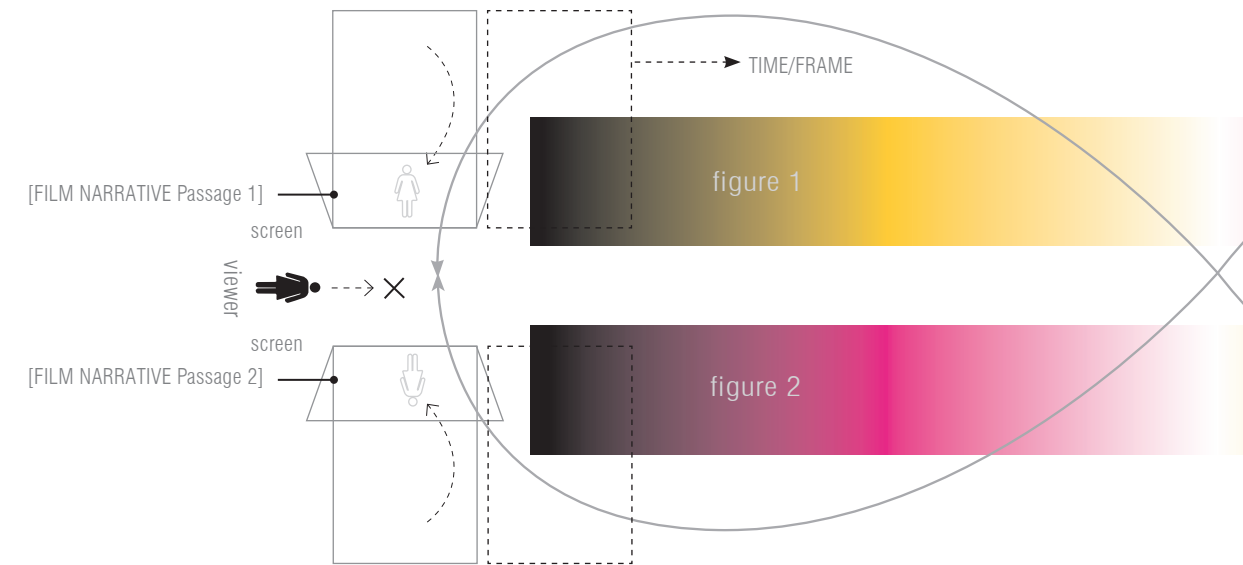

f.103

by Author

'Cycle 2 : Diagram of Light through Construction'

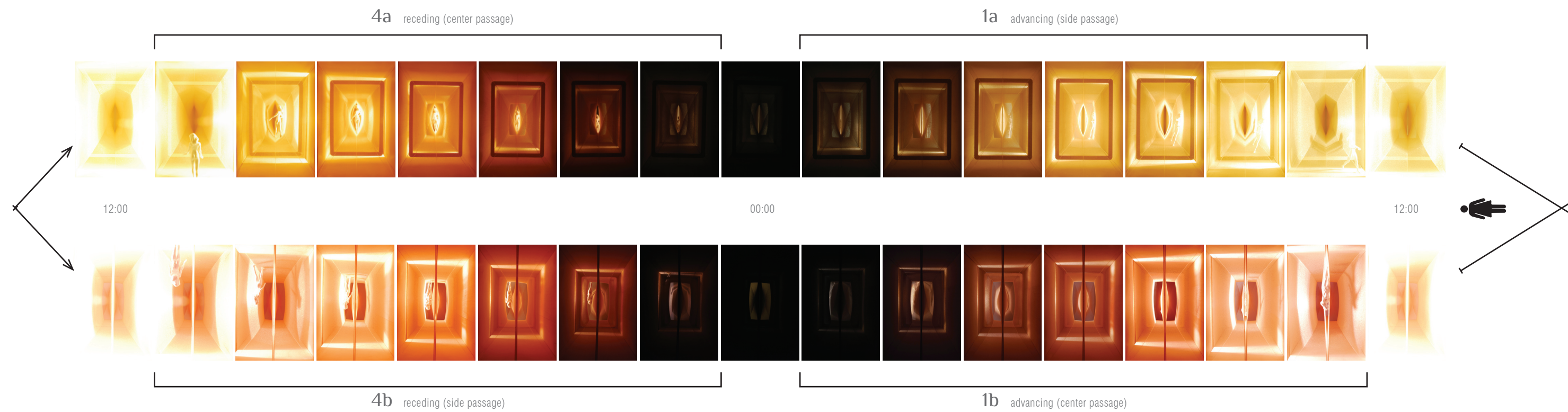

f.104

by Author 'Cycle 2 : Film Narrative in Stills'

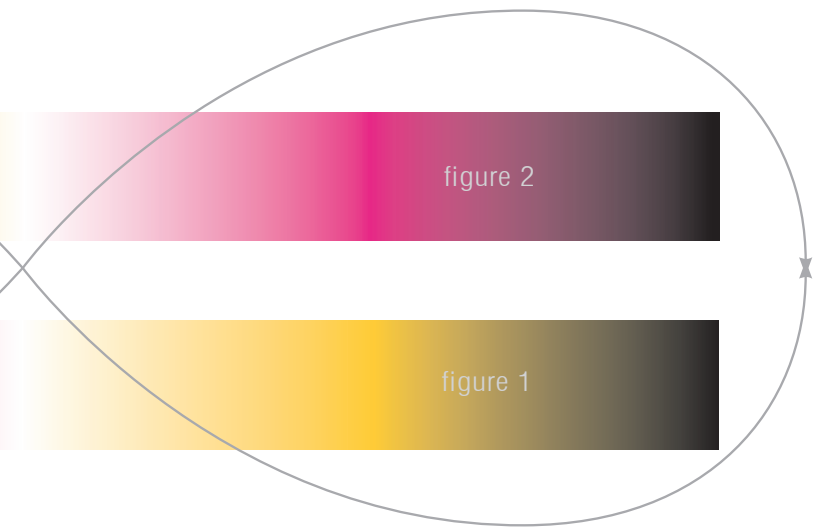

Cycle 2

Shadow

Initiator
Precept
Modeling
Narrative
Drawing

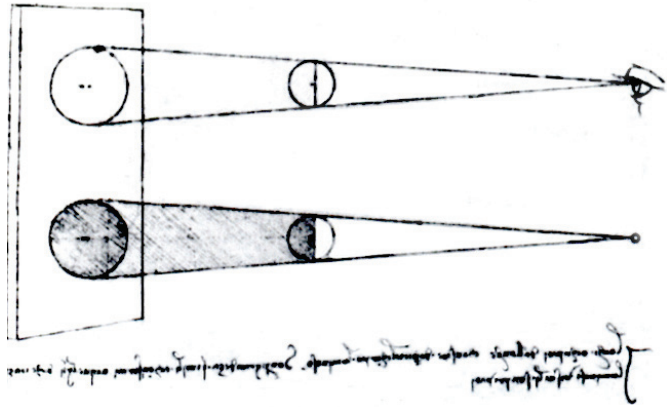

f.105 Leonardo da Vinci 'Study of Shadow Projection'

The first drawing (f.106) situates the construction in the context of time to give some notion of how the light from the diurnal cycle moves in and around it.

The subsequent drawings (f.107, f.108) take inspiration from Leonardo da Vinci's studies of an object's projection of its shadow in space (f.105), as a simple method of mapping the variance in the 'opacity' of the shadow doublings as they move through the layers and overlapping passageways of the construction. These drawings are like the mapping of dance steps, positioning both the body and its doubling in time.

f.106
(opposite) by Author 'Cycle 2 : Construction in Time'

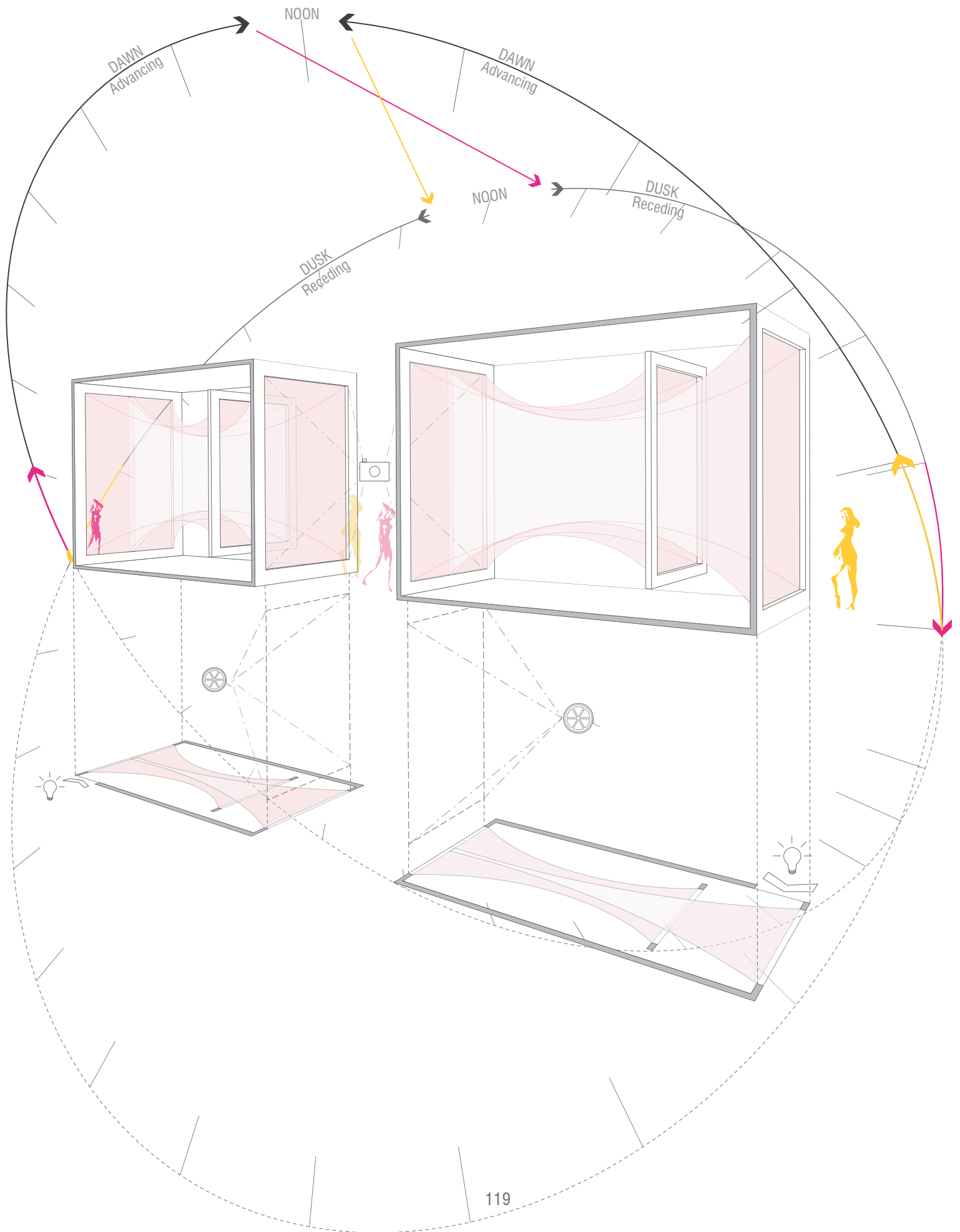

DAWN

DUSK

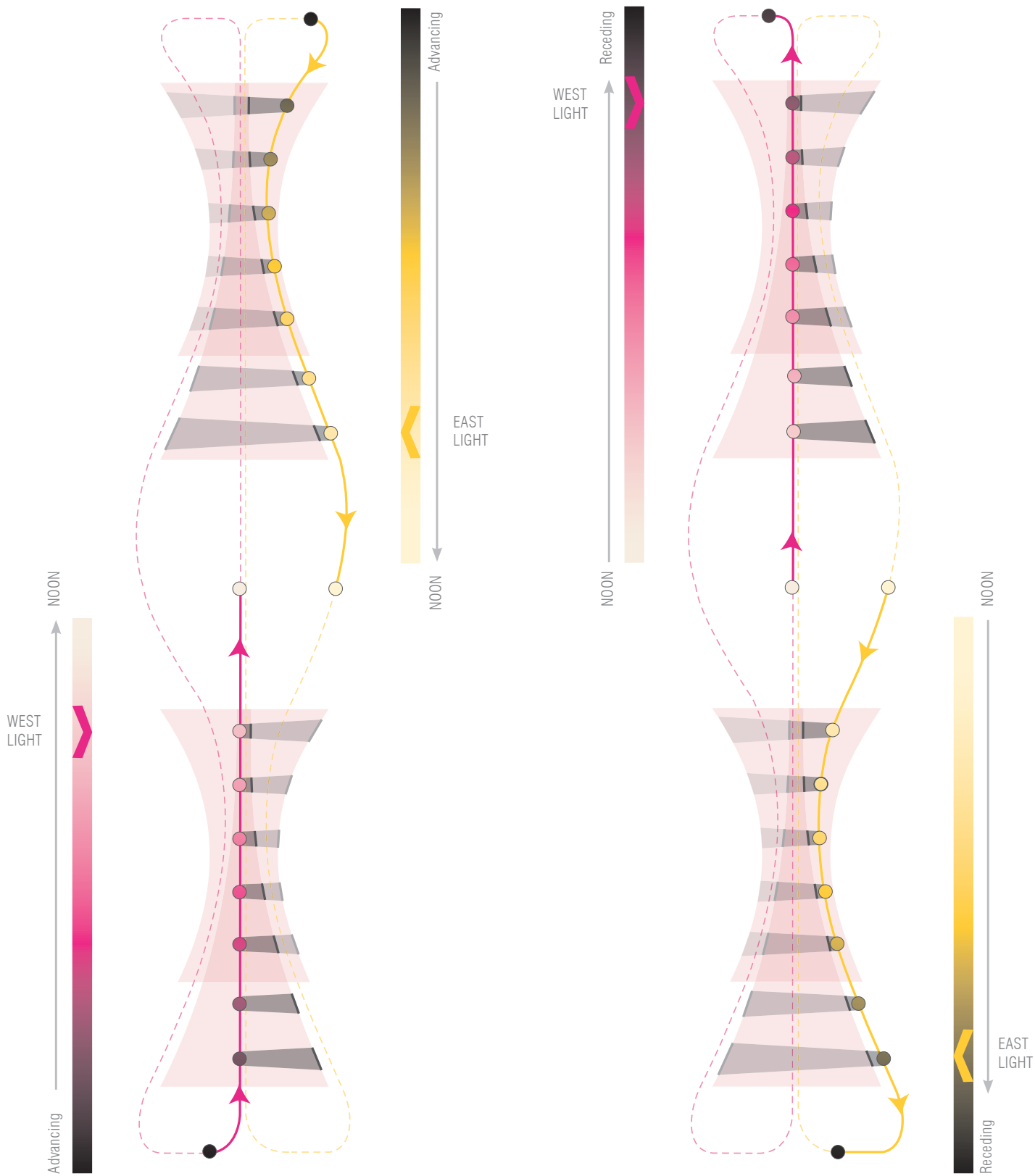

f,107

by Author 'Cycle 2 : Doubling at Dawn and Dusk (Day 1)'

DAWN

DUSK

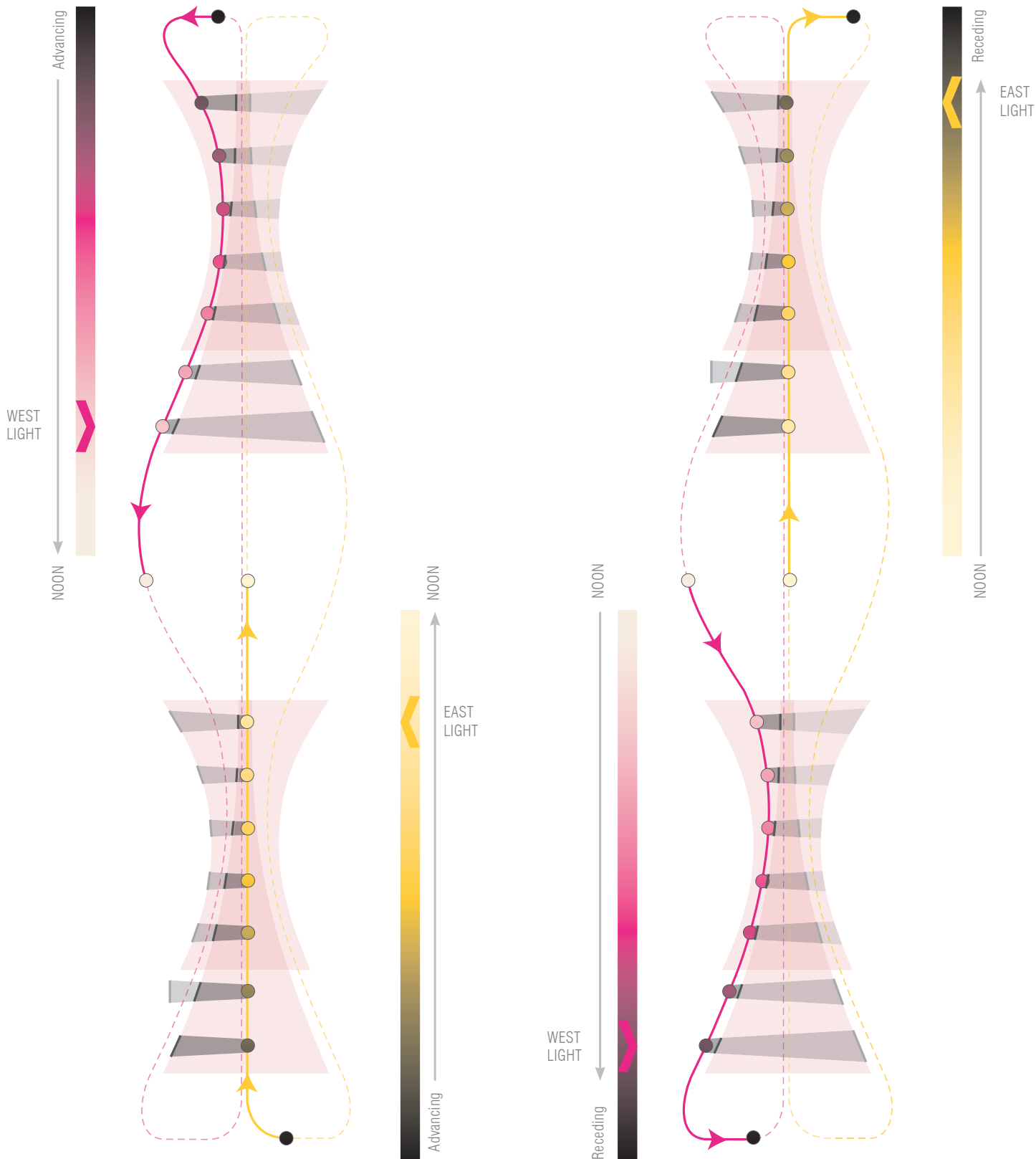

Cycle 3

Iridescence



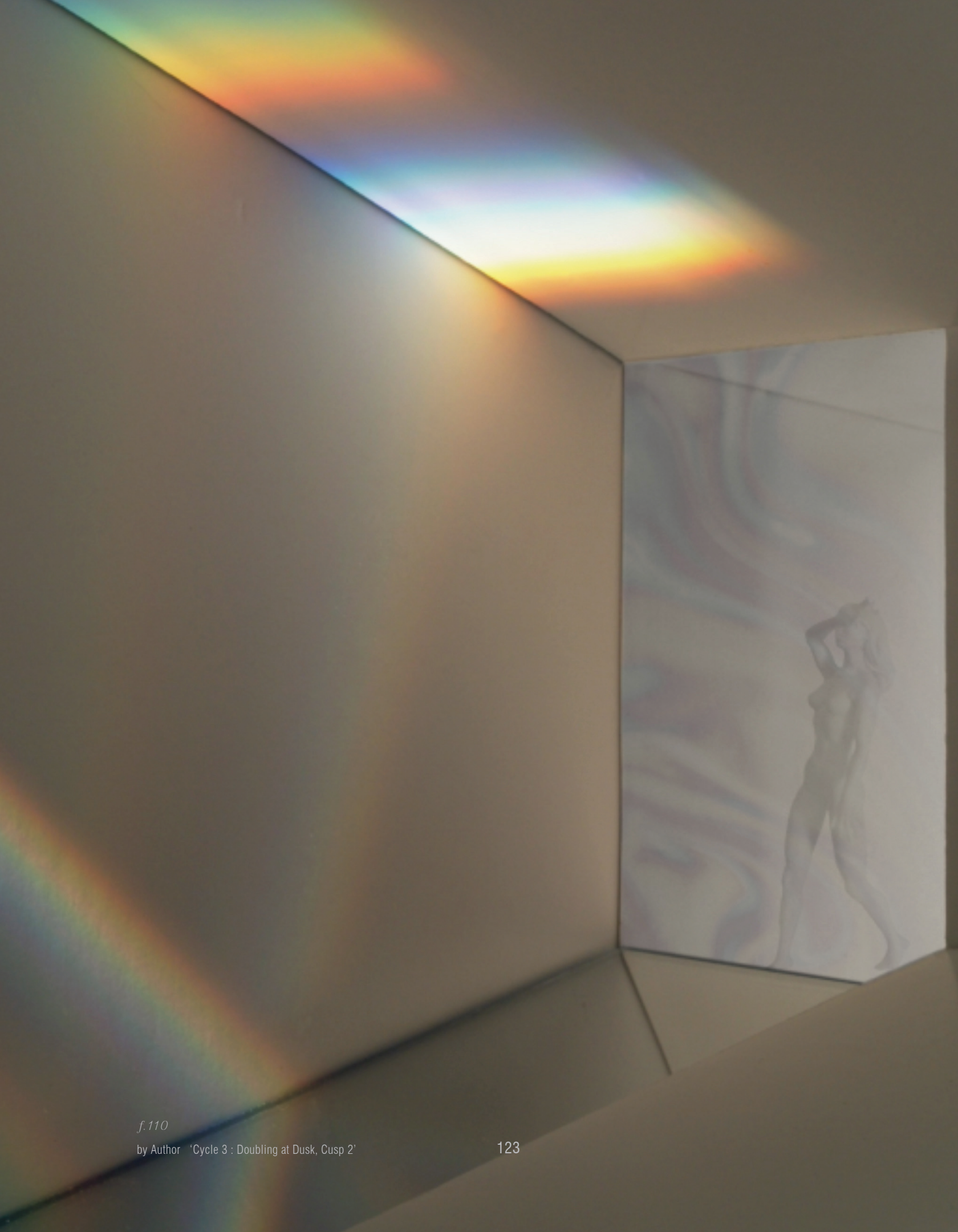

f.110

by Author 'Cycle 3 : Doubling at Dusk, Cusp 2'

Cycle 3

Iridescence

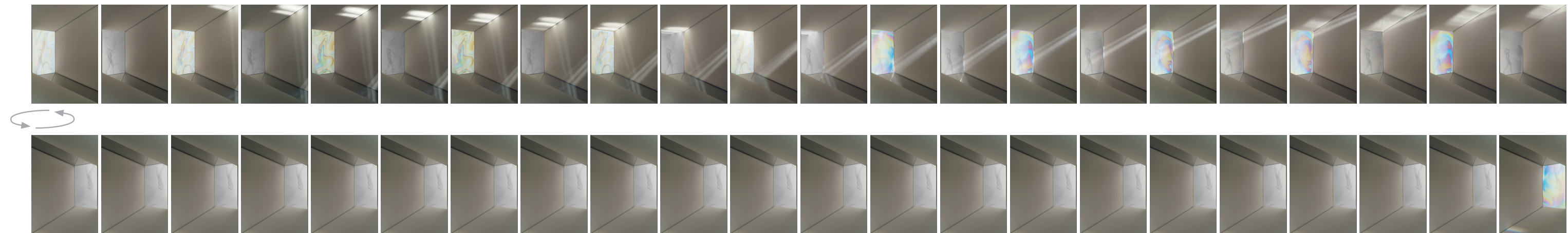

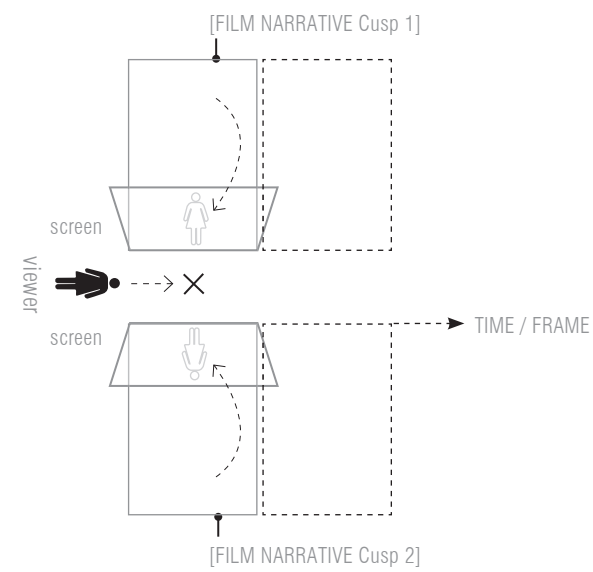

f.111 by Author 'Spatial Arrangement of Video Projection'

IRIDESCENCE: the CUSP

SYNOPSIS Eos breathes; the particulates of her breath condense to colour the sky. During this stage Hermera and Hespera stand at opposite ramping thresholds to a common space. The material stretched across the openings veils their bodies while the light that enters the space reveals each's presence to the other as a colourful exhalation across the thin surfaces that keep them apart. In the brief moment, when day's light alters from dawn to dusk, their exhalations coincide in a shared rhythm of breath.

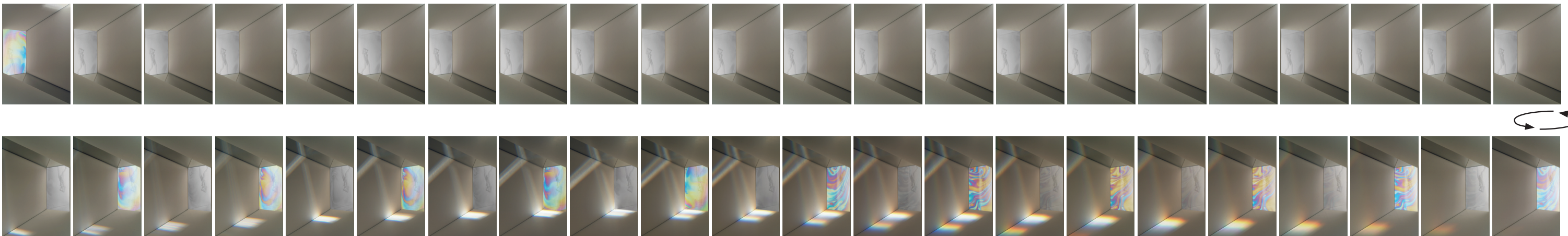



DAWN

NOON

CUSP 1



NOON

DAWN

CUSP 2

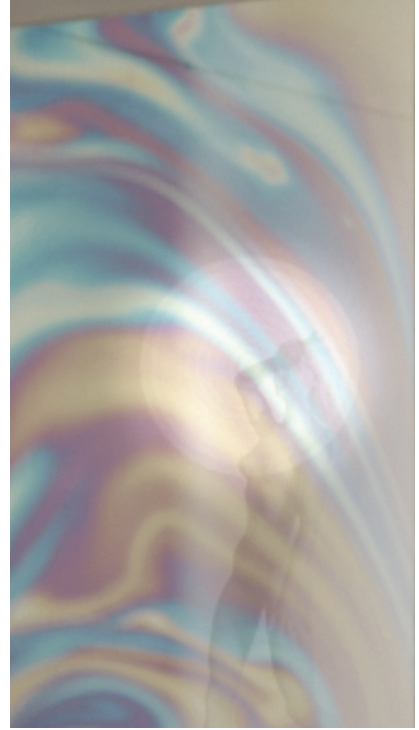
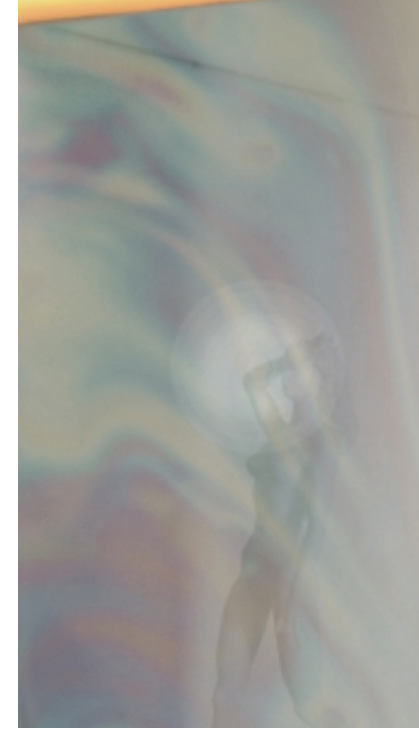

Dawn breaks.
With a hesitant inhalation
her new-born airs breach the ether
to revolve within.

With an approaching rhythm,
Dawn blushes a colourful exhalation.
Off time and in time,
together they move as a gradation
that colours the sky.

Then light leaves,
breath fades,
to bubble forth a new breath
beaming light.

f.114

by Author 'Cycle 3 : Doubling, Detail'

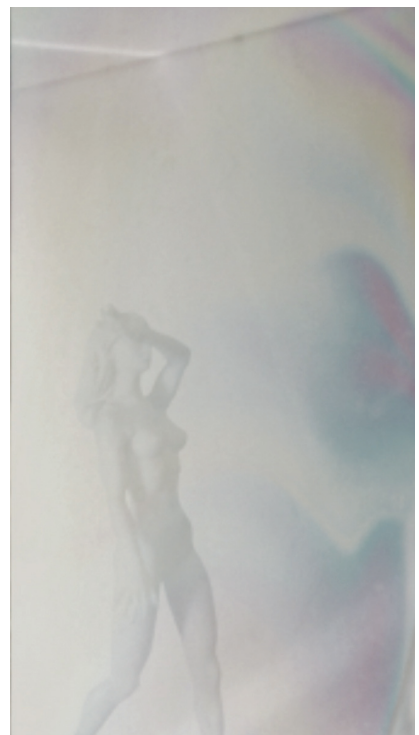

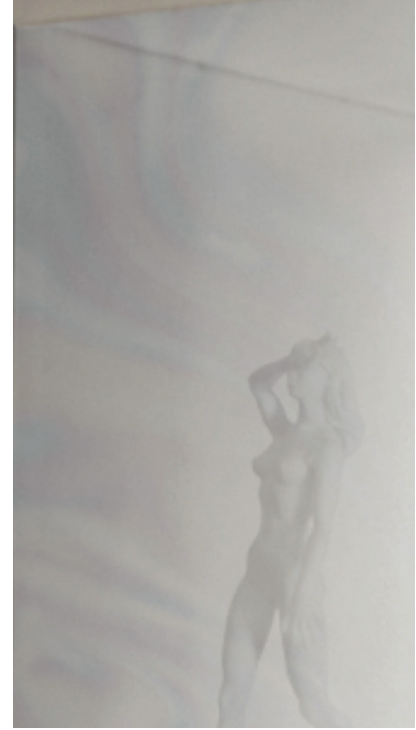
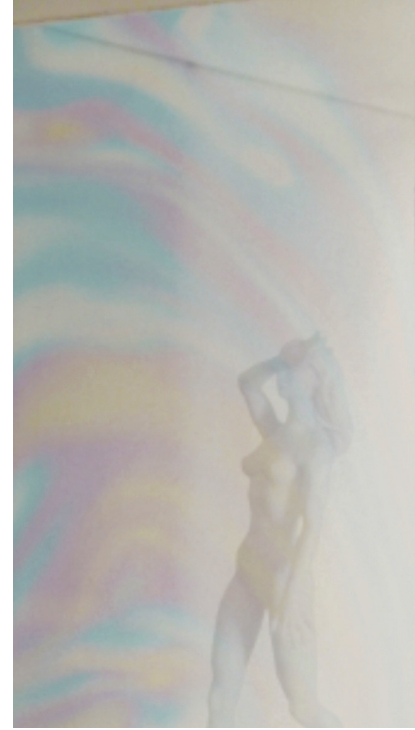
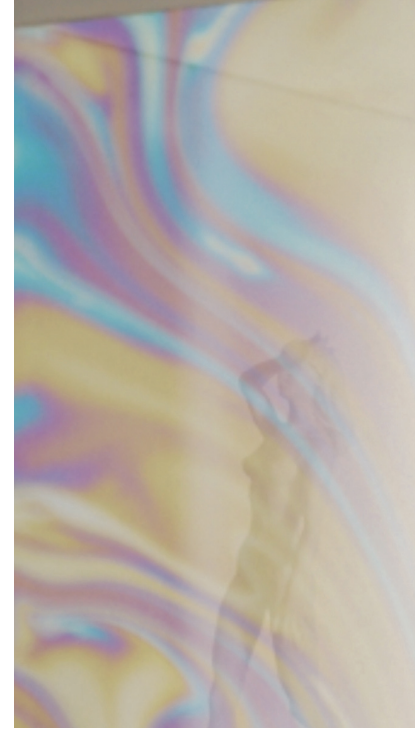

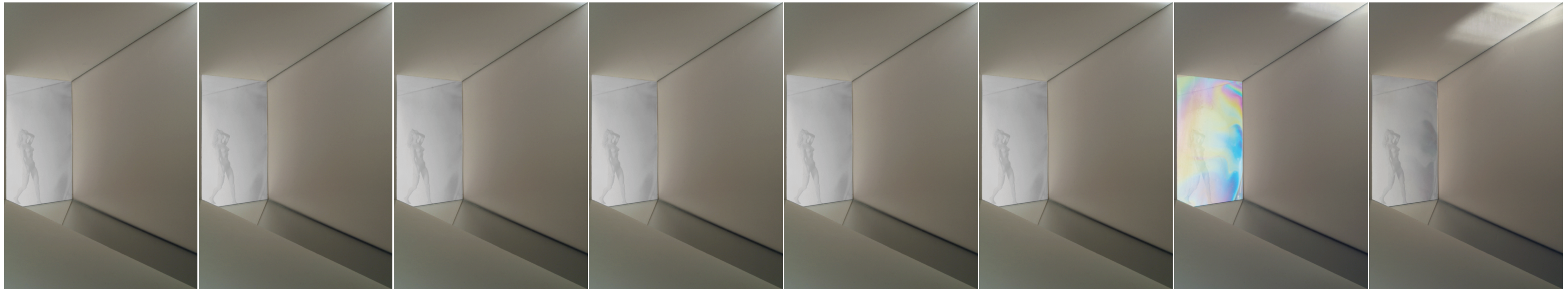

DUSK

NOON

CUSP 1



NOON

DUSK

CUSP 2

Cycle 3

Iridescence

Initiator
Precept
Modeling
Narrative
Drawing



Meaning is not in things but in the in between; in the iridescence, the interplay; in the interconnections; at the intersection, at the crossroads.

- Norman O Brown
(Brown 1966, 247)

f.116

(left) Francesca Woodman

'Some Disordered Interior Geometries' - detail

f.117

(right) Francesca Woodman 'Self Portrait Talking to Vince'

These paired photos by Francesca Woodman show her vocal breath as it exits her body, at first calmly and then violently.

In f.116 and f.117 she holds the shape of her speech between her lips; this is her vocalized internal intensions doubling into visible waves of candied translucency. In f.118 and f.119 she throws her head back and screams. The intensity of her breath explodes to splatter and colour the walls.

Breathing and vocalizing are tied together in the asphyxiation and release of air through the body. Woodman sees in these airs, a compelling force that externalizes her inner intensions; she sees a doubling of her own pent up energies as they flow out of her body in the act of vocalizing. For her, this compelling movement of breath leaving the body is something that can both stream from it in gentle waves as well as explode from it in extreme lashings out.



Ultimately, this type of doubling seems to imply that there is a colour and impact to our exhalations, that the shape and colour of our inner intensions can be seen, can touch and alter the environment as they stream into the space outside our bodies.

f.118

(left) Francesca Woodman 'Roma, May 1977 - August 1978'

f.119

(right) Francesca Woodman

'On Being an Angel, Providence, Rhode Island, 1977'

Cycle 3

Iridescence

Initiator
Precept
Modeling
Narrative
Drawing



f.120 by Author 'Colour of Breath : Collage'

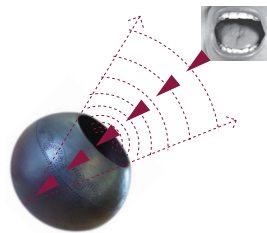

f.121 by Author 'Colour of Breath : Vocal Reaffirmation'

Inside and outside are both intimate – they are always ready to be reversed, to exchange their hostility. If there exists a border-line surface between such an inside and outside, this surface is painful on both sides.

- Gaston Bachelard
 (Bachelard 1994, 217-8)

Generated from within and released into the world, breath as emitted from the body is an acknowledgement of the intensity and realness of an experience; through the expulsion and re-apprehension of this breath, an exchange of a body's inside with its outside, one experiences an intense body reaffirming event. The following work translates Woodman's vocal exhalation as a force that makes itself apparent in a material outside the body.

F.121 shows this doubling back of the voice as received and amplified by matter. Since Woodman's work assigns a colour and shape to her doubling into voice, an interest in a material that could resonate with this emerges. The following photos (f.120, f.122) capture the ephemeral impact of breath on thin film soaps. By breathing onto large expanses, the colours swirl. The breath as it exists the body is both received by the material and alters it with its own eddies and currents. The breath is not only heard, it is seen to mix with material external to the body.

f.122
 (opposite) by Author 'Colour of Breath: Colour Change in Time'

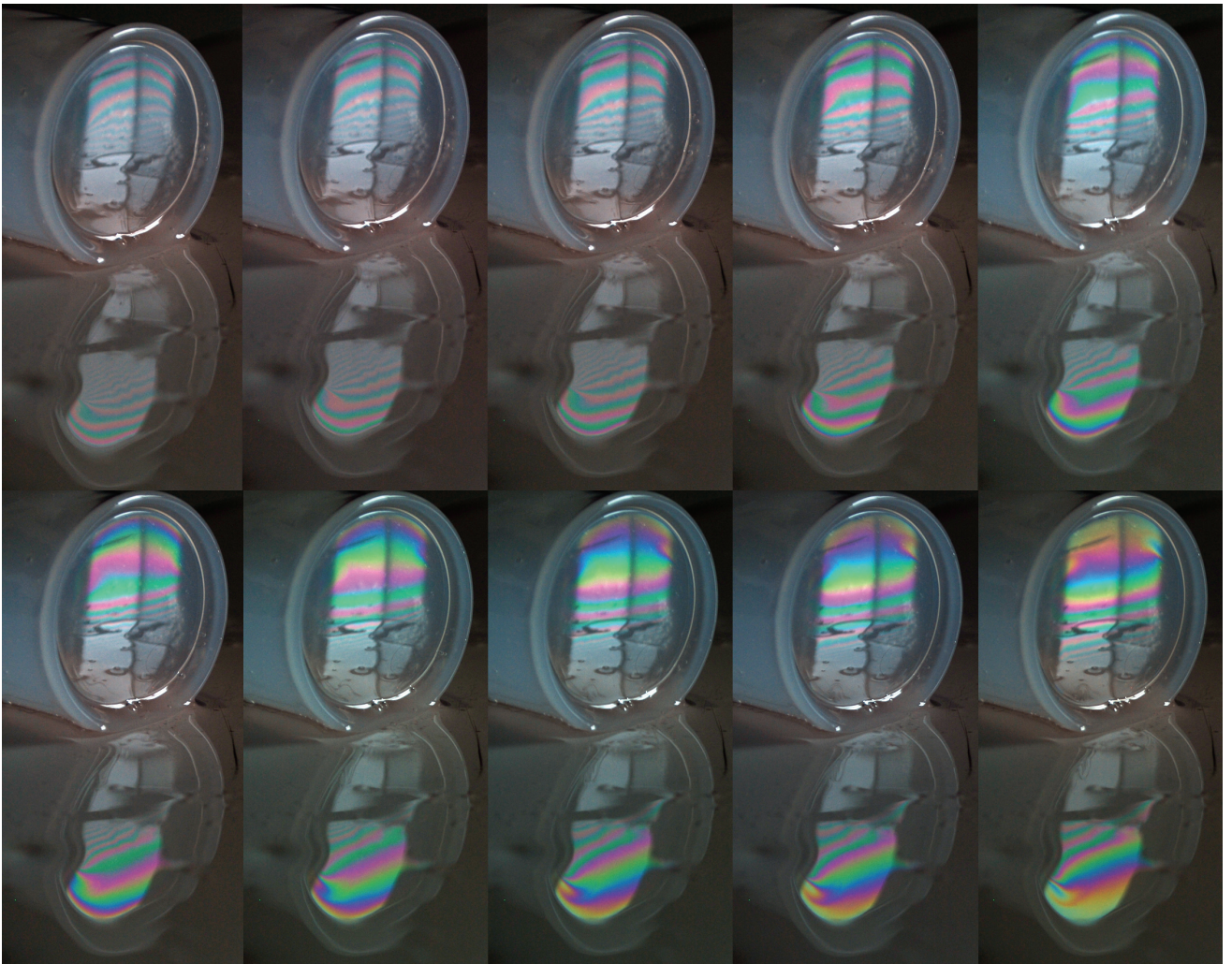
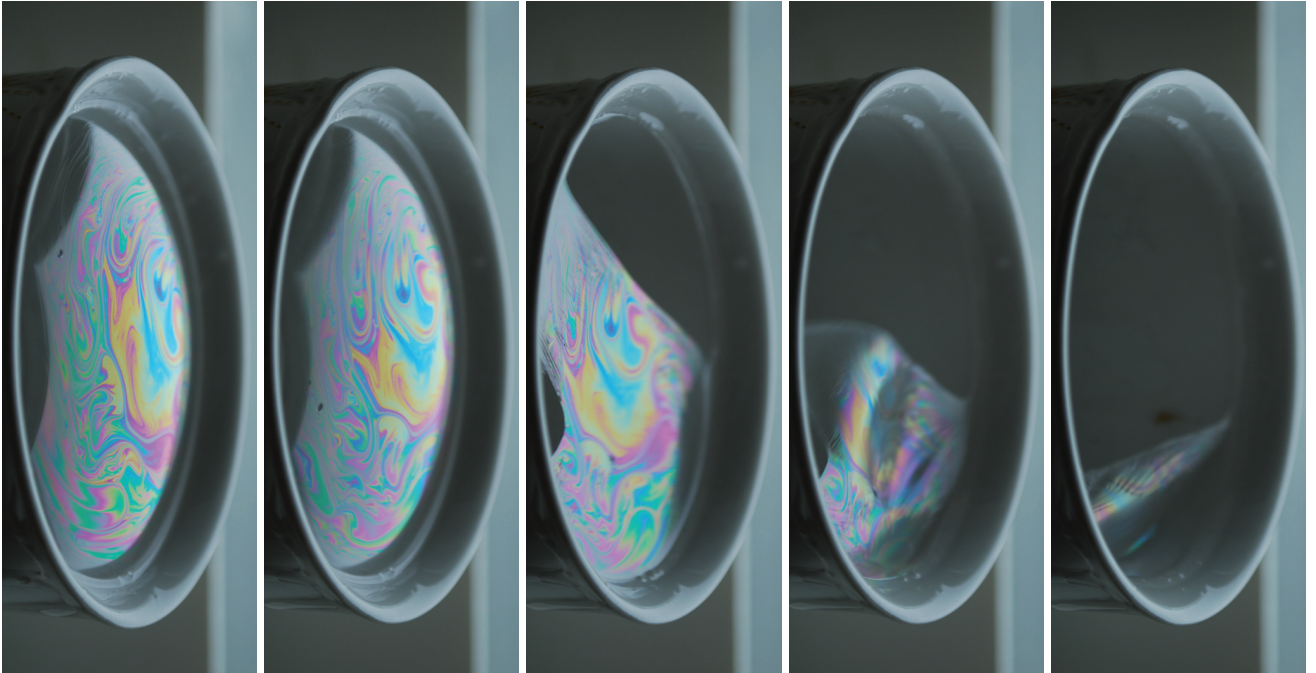

Cycle 3

Iridescence

*Initiator
Precept
Modeling
Narrative
Drawing*

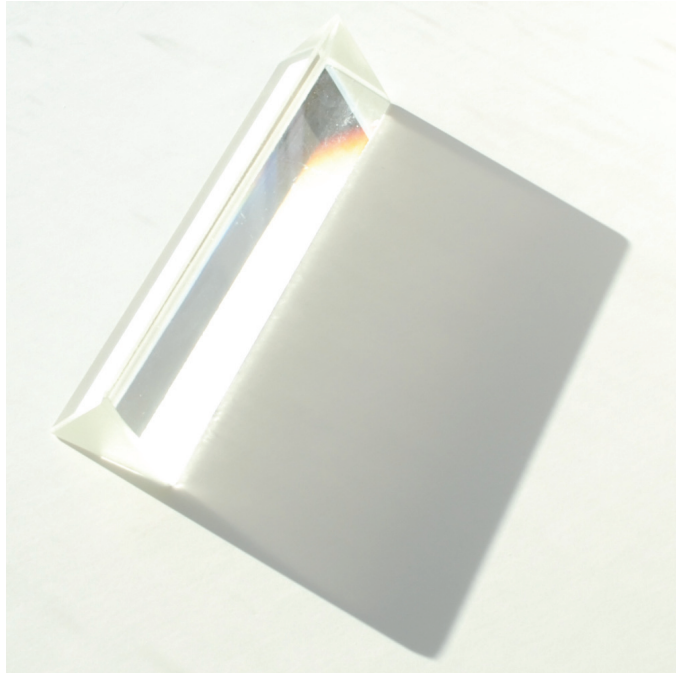

f.123 by Author 'Cycle 3 : Material, Equilateral Acrylic Prism'

While playing with the impact of breath on thin-film soaps, it is discovered that the coloured effects are only visible and most vibrant when daylight illuminates it. This property is also shared by equilateral prisms whose material properties allow them to disperse white light into the visible colour spectrum (f.123). These thin films and equilateral prisms are taken as the primary materials with which to build the third construction.

Modeling proceeded with this question in mind: how could a joint space be created in which the movement of white light into dispersed light might manifest two figures' doubling into a colourfully apprehended rhythm of breath?

A figure is placed behind a transparent film over a threshold to a space. An opposite open end to the space is manipulated so that the equilateral prism suspended in its opening projects the daylight behind it into the space (f.124). As the angle of the sun moves so does the angle of the shaft of light projected into the space. Through this guiding of light into the interior, the effects and coloured properties of the film become visible. The shaft of light physically comes into contact with the threshold at the other end for only a portion of its movement through the space.

f.124

(opposite) by Author 'Cycle 3 : Model Construction'

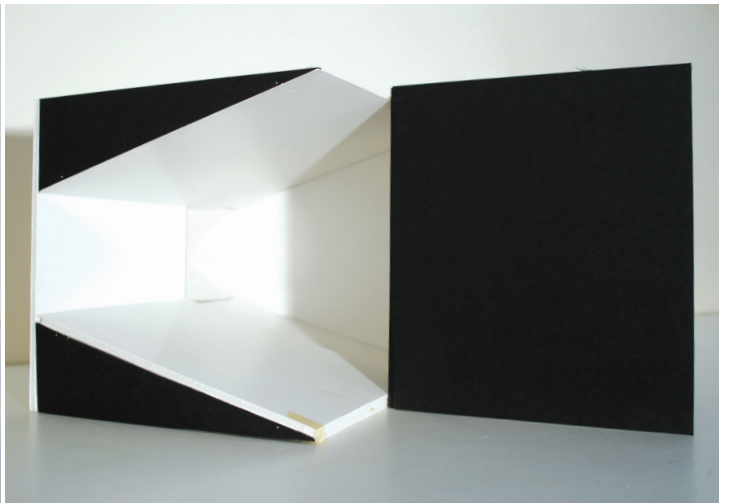
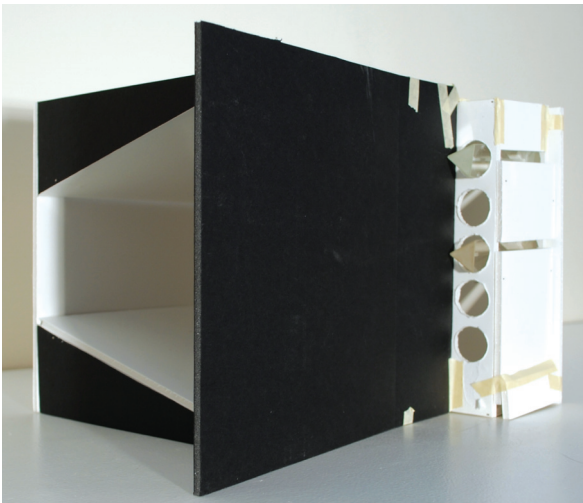
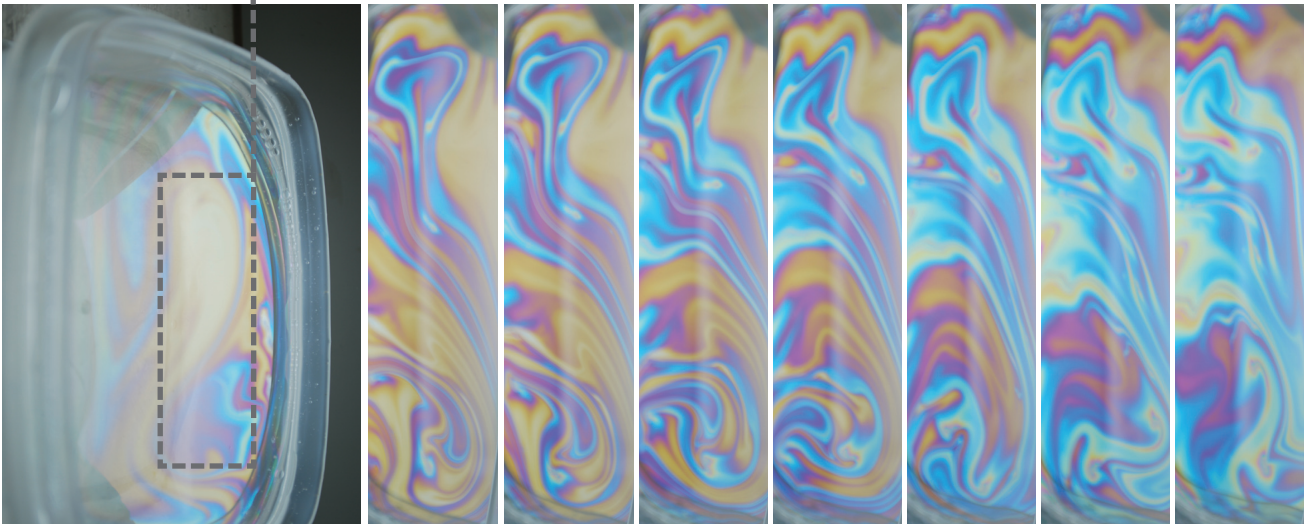
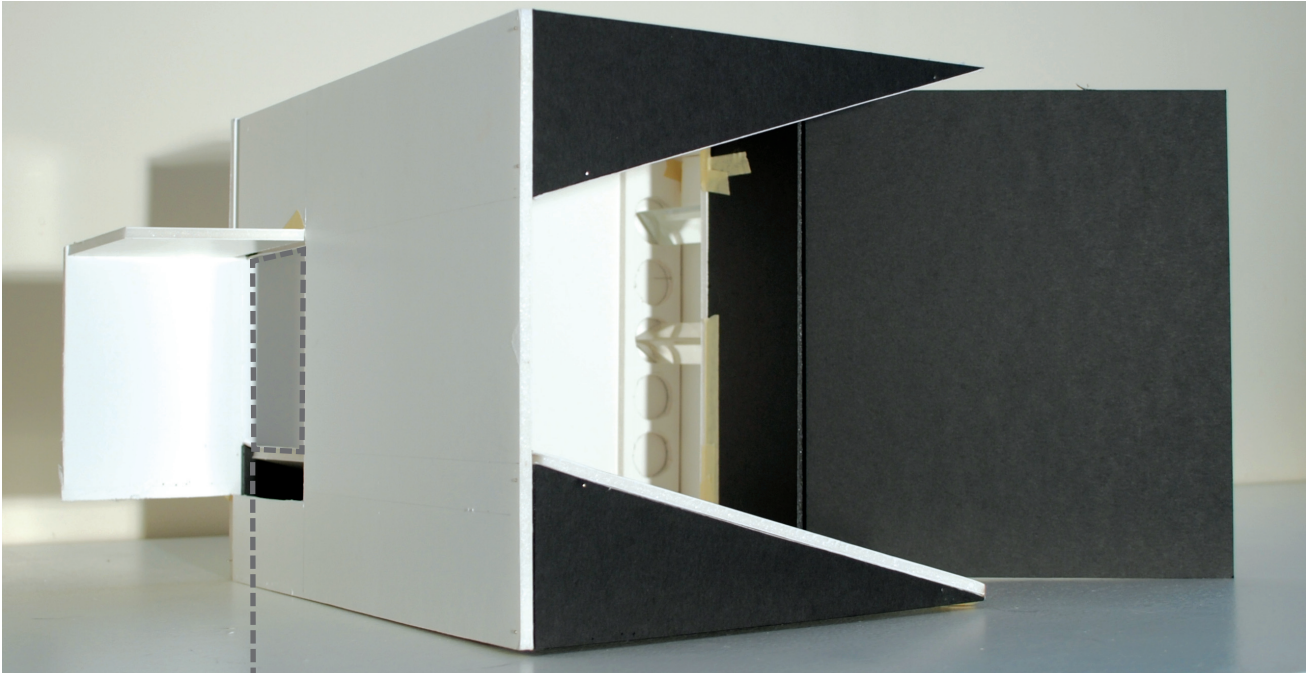

Cycle 3

Iridescence

Initiator
Precept
Modeling
Narrative
Drawing

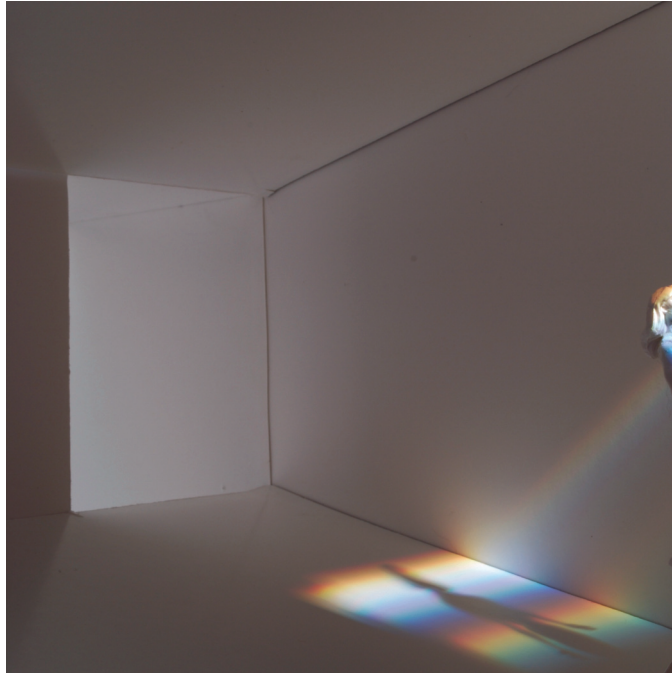

f.125

by Author 'Cycle 3 : Test Photo of Internal Lighting'

Eos's diurnal cycle is again used to structure the events as they unfold in the model. If the sun were to pass in an arc from east to west over the model, during dawn light would enter the opening with the prism from the East and illuminate the figure at its far end for a period. When the sun descends the sky into the west an identical but spatially mirrored set of openings in the model are oriented to catch its light and illuminate for a period the figure and its breath standing at its opposite threshold. In this way, two figures occupy the model by standing at opposite and off-centered thresholds into a common space.

From Dawn to Dusk the breath the figures breathe against the transparent films covering the opposite thresholds of the model are illuminated for a period creating a rhythm of inhaling and exhaling (f.128) that is in sync with the rhythm of the light moving through the common space between them. During Dawn, when light enters from the East, the angle of the sun is refracted through the prism and moves as a white shaft of light deeper into the model (f.126), illuminating the shape and colour of the figure's breath that stands at its opposite threshold. As the sun ascends to the cusp of noon and the light begins to shift into the

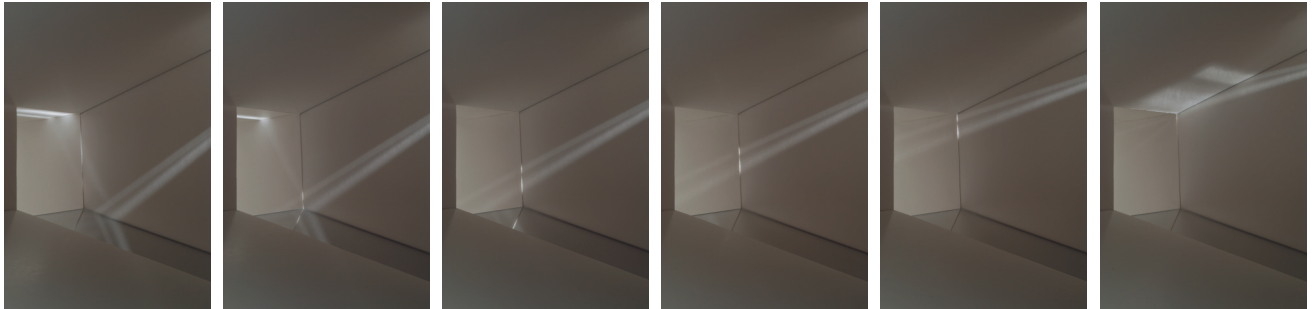

f.126
by Author 'Cycle 3 : Test Photos, white light through Threshold 1'

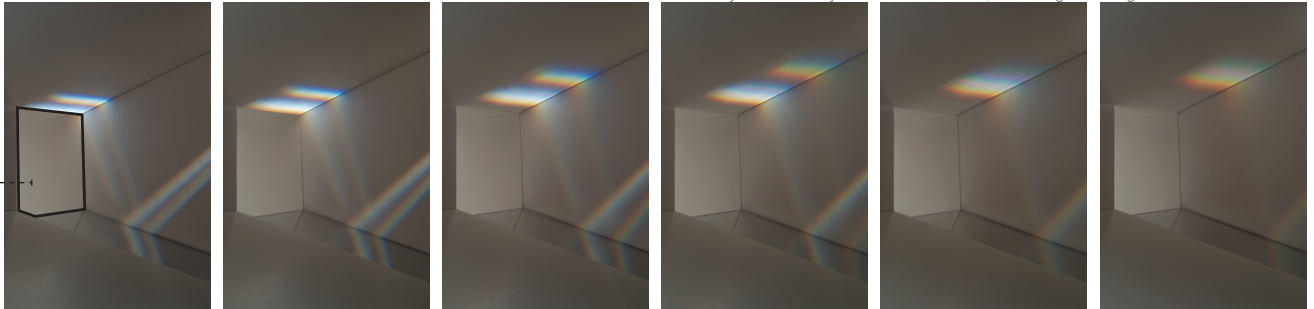

f.127
by Author 'Cycle 3 : Test Photos, dispersed light through Cusp 2'

western open end, both spaces receive light, allowing for the breaths of both figures to be illuminated in a brief moment of corresponding rhythm. As the light continues in its arc to enter into the West opening, it moves again into the common space, this time as a shaft of dispersed light (f.127), to illuminate the shape and colour of the other figure's breath. As the sun sets beneath the horizon the light of the sun withdraws, the rooms darken and the cycle begins again.

Fusion: the distinction between inner self and outside world, between subject and object, overcome.

- Norman O Brown
(Brown 1966, 253)

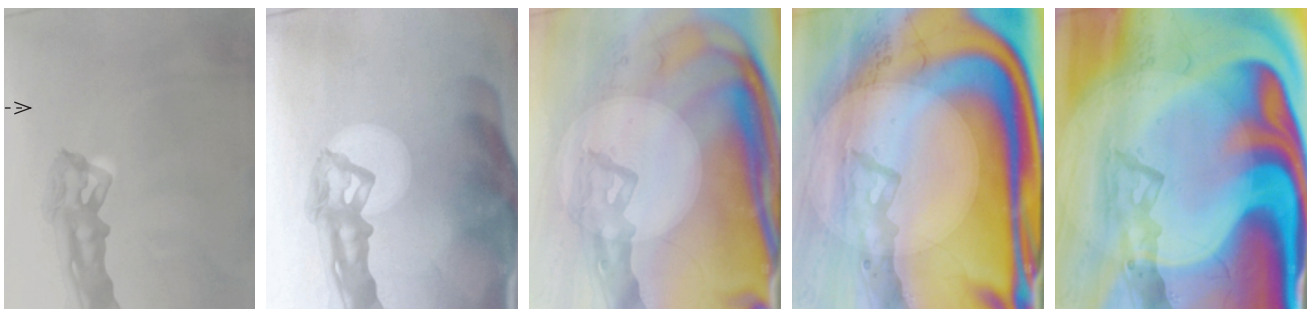

f.128
by Author 'Cycle 3 : Test Photos, exhalation on film across Cusp 2'

Cycle 3

Iridescence

Initiator
Precept
Modeling
Narrative
Drawing

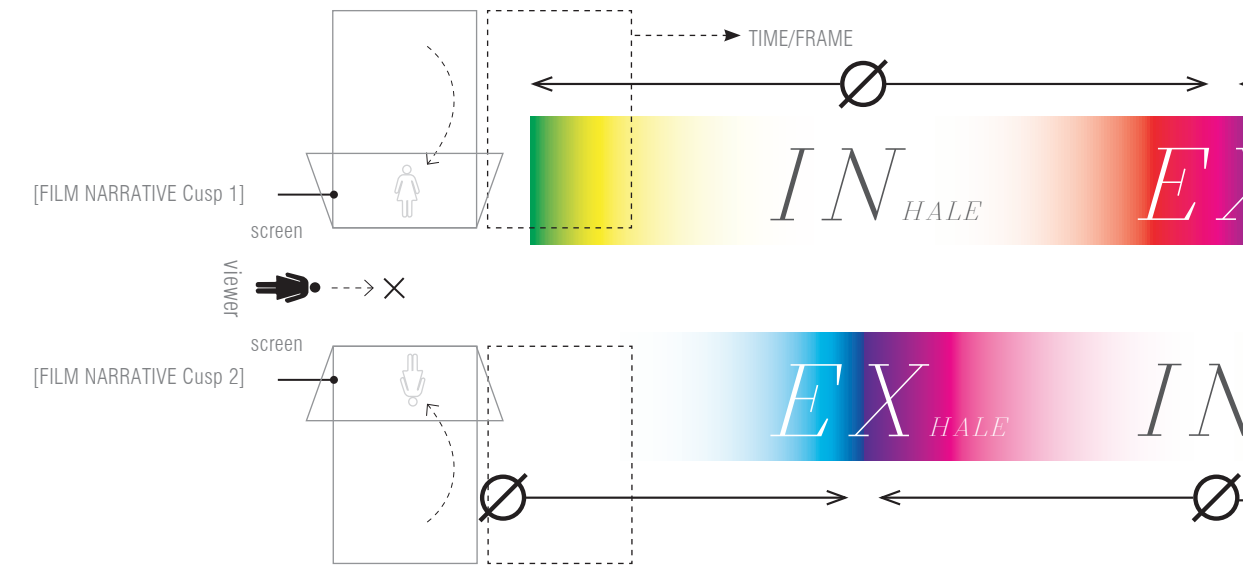

f.129

by Author 'Rhythm of Breath as a Notation'

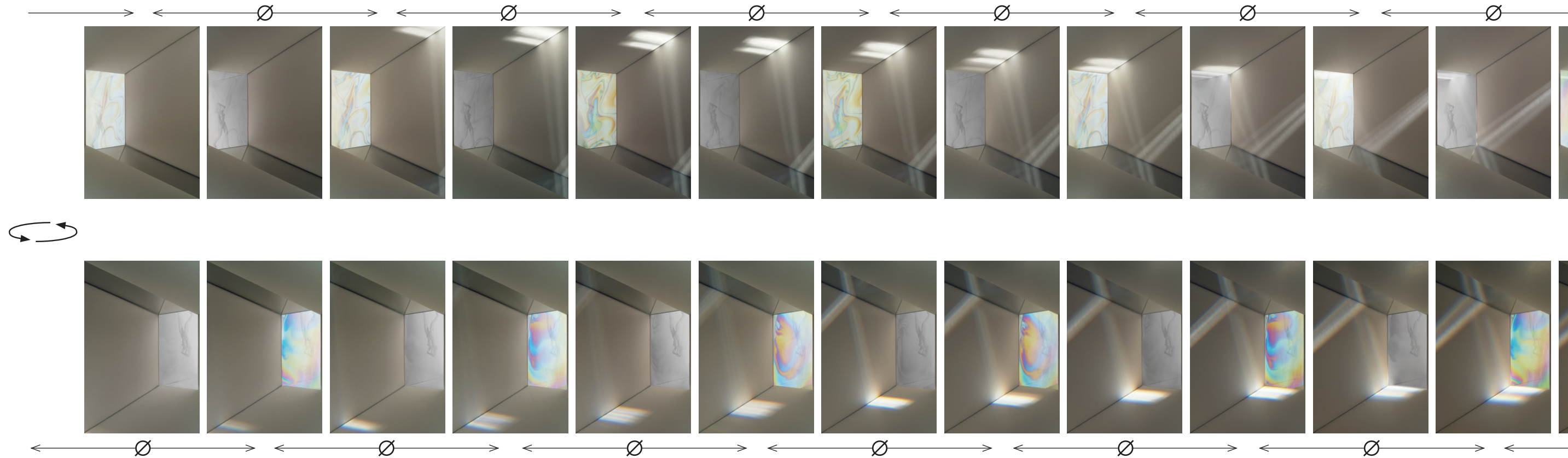

f.130

by Author 'Cycle 3 : Film Narrative in Stills'

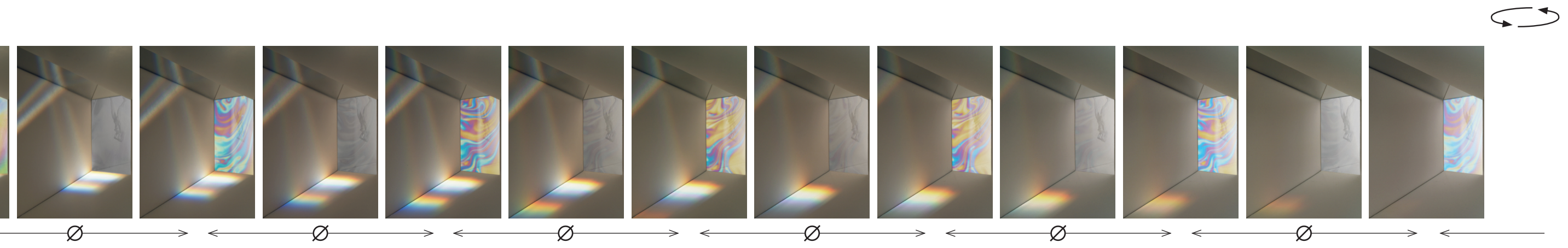
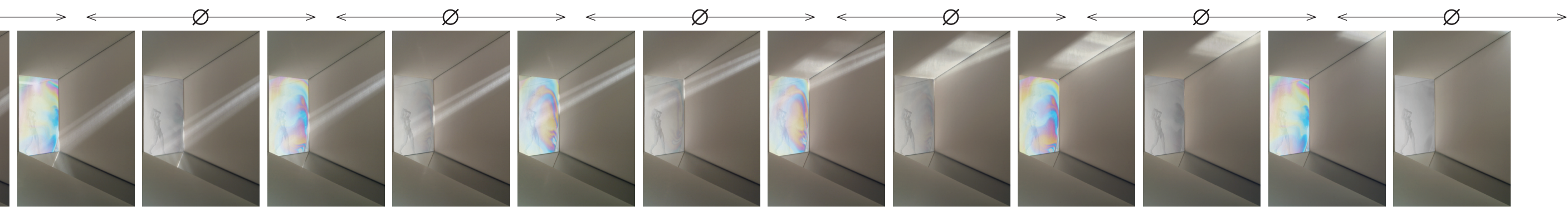
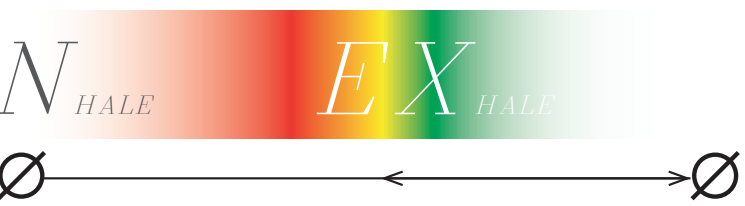

Cycle 3

Iridescence

Initiator
Precept
Modeling
Narrative
Drawing

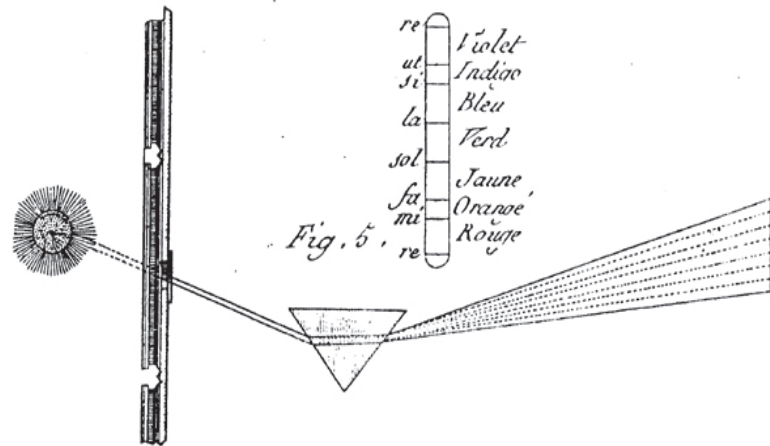

f.131

Unknown Author 'Prism Experiments'

After placing the construction in the context of time, with the arc of the sun passing from East to West over it (f.132), a cue was taken from Newton's prism experiments in which he mapped the refraction and dispersion of light as it passed through the material of various prisms (f.131). The movement of light as a beam through the respective East and West portions of the construction is mapped out in a paced rhythm that corresponds to each breath expelled by the figures standing at the thresholds to the common space. Each tick corresponds to an exhalation across the surface of the threshold, a pacing of breath to mark the passing of the day (f.132, f.133).

f.132

(opposite) by Author 'Cycle 3 : Construction in Time'

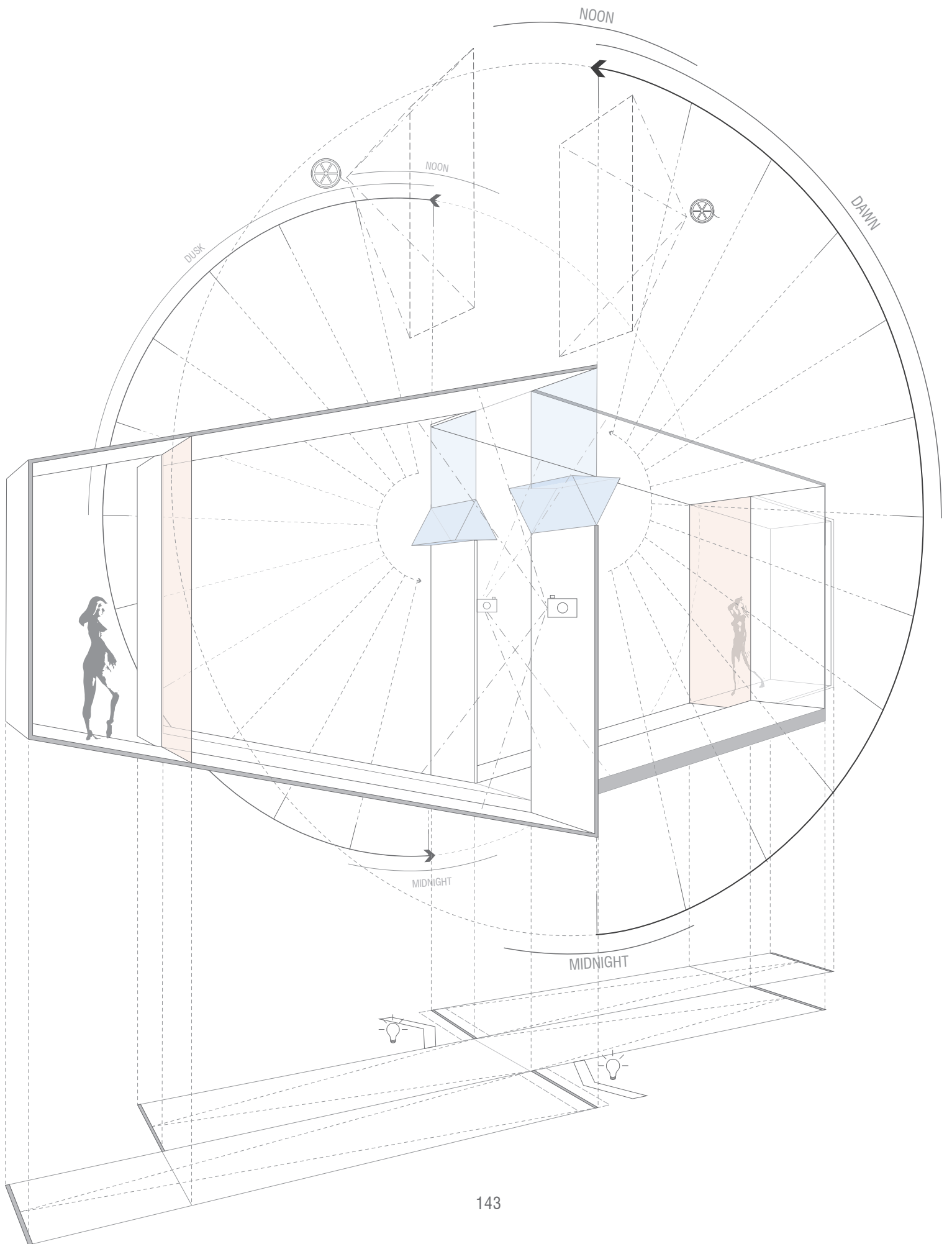

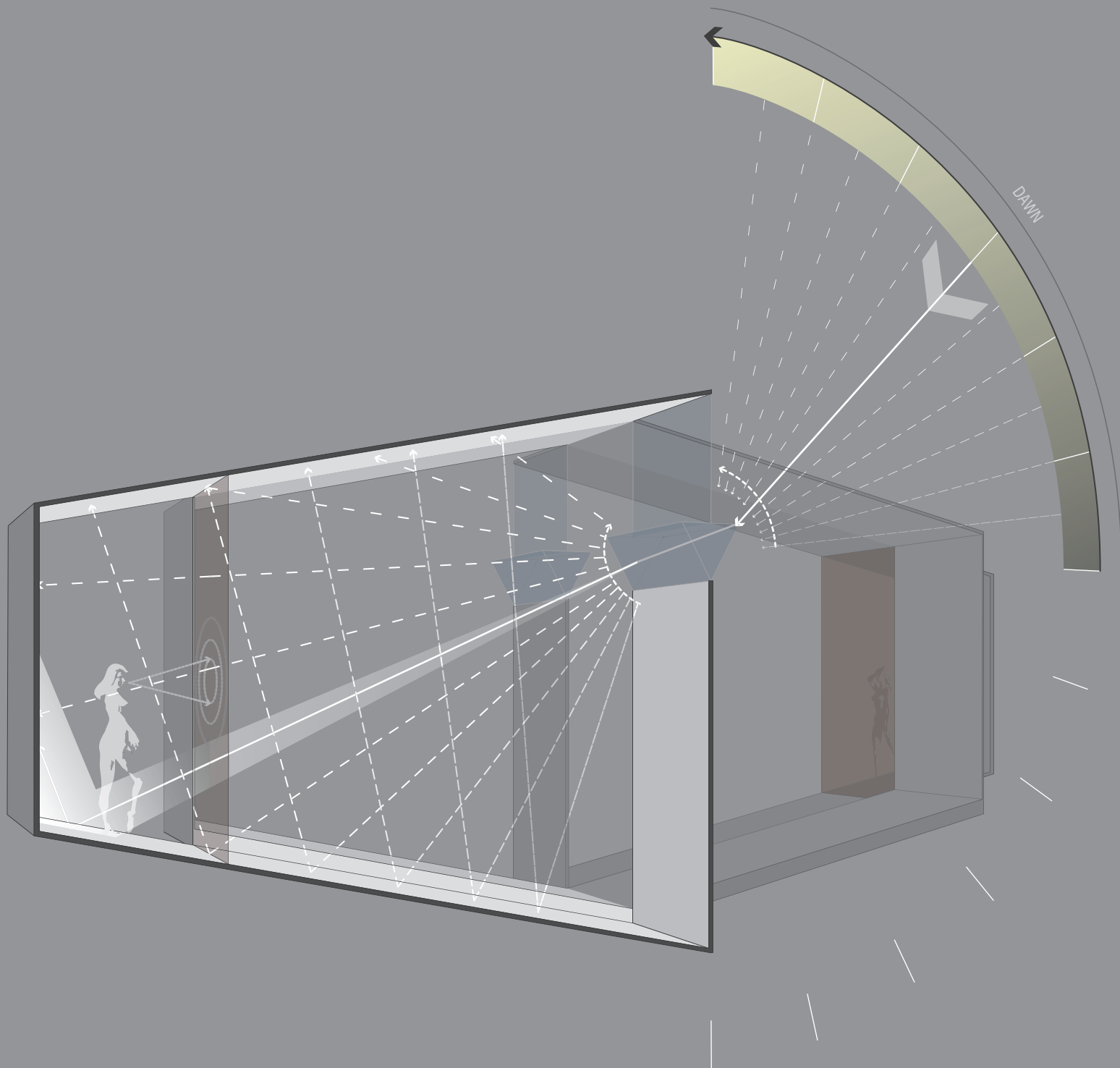

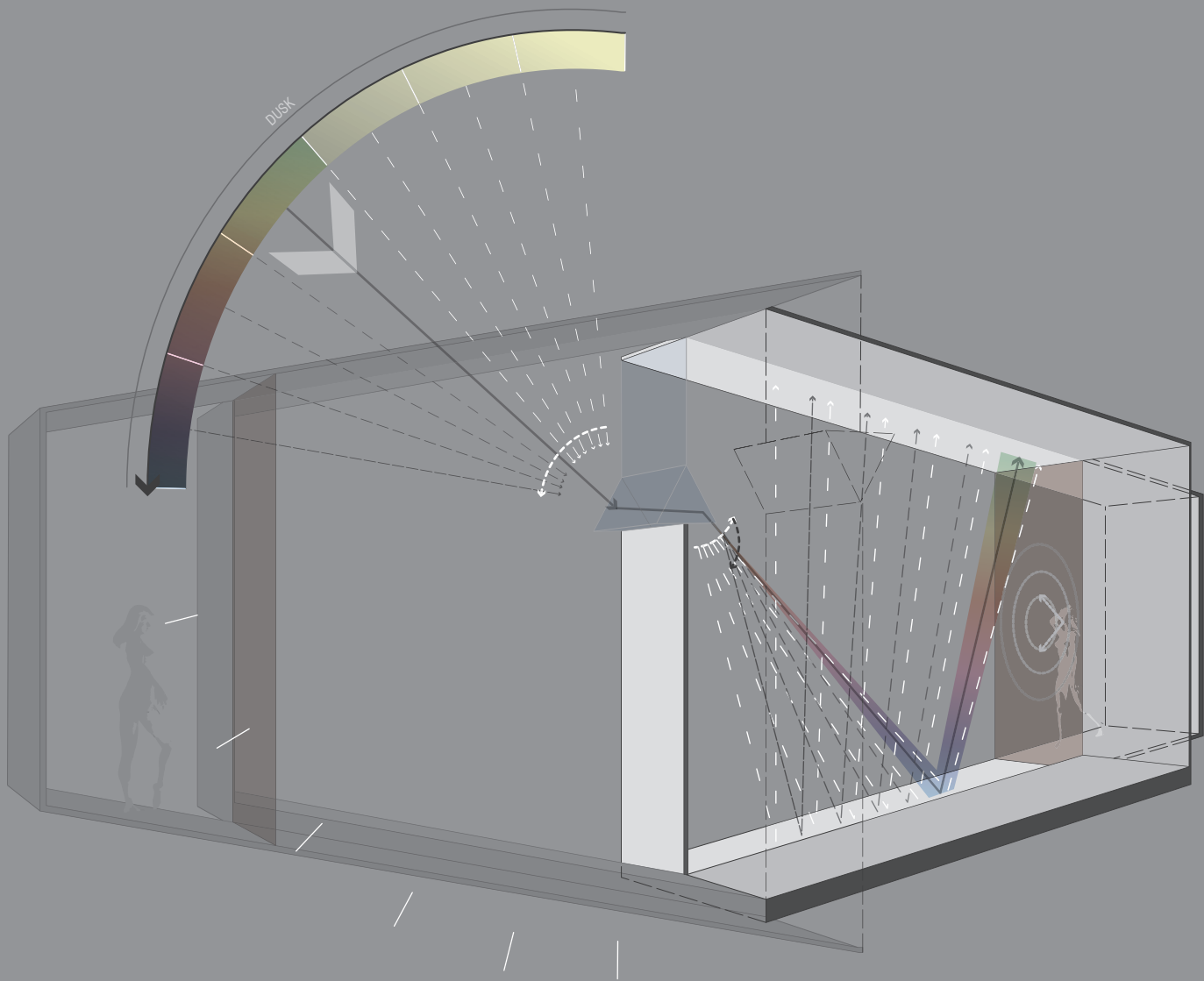

As Bataille identifies it, architecture must seek its own excesses, its bestial monstrosities, its allegiances with forces, affects, energies, experiments, rather than with ordinances, rules, function or form ...

- *Elizabeth Grosz*

(Grosz 2001, 89)

“Indeed, a particular atmospheric nimbus permeates human beings and endows their movements, gestures, and words with a certain tonality. The personal atmosphere reminds us of the phenomenon of expression: a glance, a vibration of the voice, a gesture of the hand discloses a ‘breath,’ ‘halo,’ or a ‘fine cloud’ that constitutes, in the words of Eugene Minkowski, the ‘spiritual aspect of personality.’ ... In fact, a personal atmosphere pervades the lived space around every encountered person. We sense a particular presence or aura and, with it, a certain tonality (joy, vitality, sincerity, sadness) that, like perfume, gradually infiltrates the whole surroundings.”

-Gabor Csepregi (Csepregi 2004, 171)

Throughout this thesis' investigations it has been proposed that the phenomenon of doubling manifests between the body and its environment, opening up the possibility of thinking differently about the assumed dichotomy between figure and ground - a dichotomy by which we define our bodies in space. It is a phenomenon of superimposition, blending the body's presence outside itself with the properties of matter external to it. The encounter or conscious apprehension of one's doubling invokes a different kind of occupancy of space in which one enters into a heightened sense of awareness of one's presence as it finds articulation external to the skin of our bodies. Doubling as a phenomenon of superimposition, blending the body's presence outside itself with the properties of matter external to it. As these doublings stretch out and recede with the light of day, so this personal halo of awareness expands and contracts.

The imaginative and metaphorical evocations elicited by the designs seek to express the tonality that the initiating quote by Gabor Csepregi speaks so poetically about. They aim to inspire a material imagination in the viewer that keys into the subtle perfume of our desiring bodies in space, to substantiate through the body and the phenomenon of its doubling, the dilation of a 'personal atmosphere' that pervades lived space; doubling as a 'haloed' gradation that moves between figure and ground, blending the two in a harmonized tonality.

Indeed, the designs attempt to approach architecture, not as



f.135

Francesca Woodman 'Roma, May 1977 - August 1978'

an object of desire, but as a registration of the body's desires through doubling, where the human figure and its doubling do not autonomously inhabit the architecture; they compose it with their movements and the degree to which the doublings are registered within the material of the surroundings. Here the architecture is a continually transforming atmosphere whose character is dependent on the body and its doubling as they advance and recede with the comings and goings of light. This kind of environment is sympathetic to the body, addressing it, not in form bound anthropomorphic imitation, but in a direct and explicitly material responsiveness to the registration of the body's expanded presence as it moves through space and time.

Doubling allows us to see ourselves as Francesca Woodman's camera does, attempting to unite with the matter of the world.

In Guy de Maupassant's short fiction "Le Horla," the protagonist is haunted by an invisible presence that performs actions as if it were a mysterious doubling of himself. In pursuit of annihilating this entity, he finds himself facing a mirror and, terrified, recalls, "I did not see myself in my mirror. The glass was empty, clear, deep, brightly lit, but my reflection was missing, though I was standing where it would be cast." Beyond the uncanniness associated with the absence of his reflection, a reading of "Le



f.136

Francesca Woodman 'Roma, May 1977 - August 1978'

Horla” could align itself with an anxiety tied up in our relationship with the phenomenon of doubling itself.

The word ‘Horla’, translated from French into English, means ‘out there.’ Given the research and interpretations that emerge to contextualize the phenomenon of doubling throughout this thesis, I am inclined to read the haunting within this story as that of the protagonist by his own ‘outsides.’ He senses this entity, as a self similar presence and is terrorized by its various manifestations, and yet curiously, as in the mirror sequence, his own ‘natural’ doublings never appear where or as they should.

This passage touches on why this author feels an exploration of doubling as it can emerge within architecture is both merited and needed. Given emergent information and ‘responsive’ technologies in building practice, what happens when we can no longer see ourselves in the mirror, or when we begin to see ourselves differently? How might we prevent our ‘outsides’ from becoming a ghosted doubling that terrorizes instead of moving with us in our bonding with the world? This thesis uses the rhythm of the doubling’s unfolding in time to induce us into a trance, to remind ourselves of the perfume of our bodies as we are presented within the environment and the desire to connect with what is out there that wrestles within us.

References

- Alexander, Christopher. 2002. *Phenomenon of life : An essay on the art of building and the nature of the universe*. Center for environmental structure series 9. Berkeley, CA: Center for Environmental Structure.
- Arakawa, Shusaku. 1988. From blank to spacetime. *Pratt Journal of Architecture* 2: 146-147.
- Arakawa, Shusaku, and Madeline Gins. 2002. *Architectural Body*. Tuscaloosa ; London: The University of Alabama Press.
- . 1994. *Arakawa and madeline gins : Architecture, sites of reversible destiny : Architectural experiments after auschwitz-hiroshima*. Art and design monographs. London ; New York, NY: Academy Editions ; Distributed to the trade in the U.S.A. by St. Martin's Press.
- . 1988. *Mechanism of meaning*. New 3rd ed. New York: Abbeville Press.
- Arnold, Paul, and Ruby Cohn. 1963. The artaud experiment. *The Tulane Drama Review* 8 (2) (Winter): 15-29.
- Artaud, Antonin. 1972. *Collected works*. London: J. Calder.
- . 1958. *Theater and its double*. trans. M.C. Richards. New York: Grove Press.
- Artaud, Antonin, and Jack Hirschman. 1965. *Antonin artaud anthology*. 2nd ed. San Francisco: City Lights Books.
- Artaud, Antonin, and Margit Rowell. 1996. *Antonin artaud : Works on paper*. New York: Museum of Modern Art ; Distributed by Abrams.
- Bachelard, Gaston. 19uu. *Psychoanalysis of fire*. trans. A. C. M. Ross. Boston: Beacon Press.
- . 1994. *Poetics of space*. trans. M. Jolas. Boston: Beacon Press.
- . 1983. *Water and dreams : An essay on the imagination of matter*. Dallas: Pegasus Foundation.
- Bersani, Leo. 2004. Artaud, defecation and birth. In *Antonin artaud : A critical reader*, ed. Edward Scheer, 96-106. London ; New York: Routledge.
- Binet, Hélèn, Roberto Casati, Werne Oechslin, and Tadao Ando. 2002. *Geheimnis des schattens : Licht und schatten in der architektur = the secret of the shadow : Light and shadow in architecture*. Tübingen ; New York, NY: E. Wasmuth ; Available through D.A.P.
- Bloomer, Jennifer, and Kahn, Andrea. 1991. *Drawing/Building/Text*. New York, N.Y.: Princeton Architectural Press.
- Bois, Yve Alain, and Rosalind E. Krauss. 1997. *Formless : A user's guide*. New York ; Cambridge, Mass.: Zone Books ; Distributed by MIT Press.
- Bronk, William. 1997. *Life supports : New and collected poems*. New ed. Jersey City, NJ: Talisman House Publishers.
- Brown, Norman Oliver. 1966. *Love's body, by norman O. brown*. New York: Random House.
- Caillois, Roger, and John Shepley. 1984. Mimicry and legendary psychasthenia. *October* 31 (Winter): 17-32.
- Carroll, Lewis. 1974. *Alice's adventures in wonderland : Through the looking-glass, and other writings*. Carlton House.
- Carson, Anne. 1995. *Glass, irony, and god*. New York: New Directions Book.

- Cataldi, Sue L. 1993. *Emotion, depth, and flesh : A study of sensitive space : Reflections on merleau-ponty's philosophy of embodiment*. Albany, N.Y.: State University of New York Press.
- Csepregi, Gabor. 2004. On Sound Atmospheres. In *Aural Cultures*, ed Jim Drobnick, 169-178. Toronto: YYZ Books.
- Cixous, Hélène. 1999. *Third body*. Evanston, Ill.: Hydra Books/Northwestern University Press.
- Crary, Jonathan, and Sanford Kwinter. 1992. *Incorporations*. Zone (series). New York, NY: ZONE.
- Deleuze, Gilles, and Francis Bacon. 2003. *Francis bacon : The logic of sensation*. Minneapolis: University of Minnesota Press.
- Deleuze, Gilles, and Félix Guattari. 1994. *What is philosophy?*. European perspectives. New York: Columbia University Press.
- Eigen, Edward. 2001. Dark space and the early days of photography as a medium. *Grey Room* (3) (Spring): 91-111.
- Etin, Richard A. 1998. Aesthetics and the spatial sense of self. *The Journal of Aesthetics and Art Criticism* 56 (1) (Winter): 1-19.
- Marco Frascari, Jonathan Hale, and Bradley Starkey, eds. 2007. *From models to drawings*. Critiques ; New York: Routledge.
- Feuerstein, Marcia. 2002. Inside the Bauhaus' Darker Side: On Oskar Schlemmer. In *Body and building : Essays on the changing relation of body and architecture*, eds. Georges Dodds, Robert Tavernor, and John Rykwert, 225-235. Cambridge, Mass. ; London: MIT Press.
- Goffi, Federica. 2007. Architecture's twinned body. In *From models to drawings*, eds. Marco Frascari, Jonathan Hale, and Bradley Starkey, 88-98. New York: Routledge.
- Goodall, Jane. 1994. *Artaud and the gnostic drama*. Oxford: Clarendon Press.
- Grosz, Elizabeth A. 2001. *Architecture from the outside : Essays on virtual and real space*. Writing architecture. Cambridge, Mass. ; London: MIT Press.
- Hauptmann, Deborah, and Bart Akkerhuis. 2006. *Body in architecture*. Rotterdam: 010 Publishers.
- Hawkins, Erick. 1992. *Body is a clear place and other statements on dance*. Pennington, NJ: Princeton Book Co.
- Hendrix, John. 2003. *Architectural forms and philosophical structures*. New York ; Oxford: Peter Lang.
- Hill, Jonathan. 2006. *Immaterial architecture*. London ; New York: Routledge.
- . 2001. *Architecture : The subject is matter*. London ; New York: Routledge.
- Howes, David. 2005. *Empire of the senses : The sensual culture reader*. Oxford ; New York: Berg.
- Hughes, Ted. 1984. *River*. 1st U.S. ed. New York: Harper & Row.
- Kahn, Douglas. 1999. *Noise, water, meat : A history of sound in the arts*. Cambridge, Mass. ; London: MIT Press.

- Kahn, Douglas, and Gregory Whitehead. 1992. *Wireless imagination : Sound, radio, and the avant-garde*. Cambridge, Mass.: MIT Press.
- Kapoor, Anish, and Nicholas Baume. 2008. *Anish Kapoor : Past, present, future*. Boston, MA: Institute of Contemporary Art, Boston ; Cambridge, Mass.: MIT Press.
- Kapoor, Anish, and Anthony Vidler. 2004. *Anish Kapoor : Whiteout*. Milano: Charta.
- Krell, David Farrell. 1997. *Archetecture : Ecstasies of space, time, and the human body*. Albany, NY: State University of New York Press.
- LaBelle, Brandon. 2006. *Background noise : Perspectives on sound art*. New York: Continuum International.
- Lahkovsky, Georges. 1951. *The secret of life : Cosmic rays and radiations of living beings*. 2nd rev. ed. trans. M. Clement. Surrey: Clark & Son.
- Leach, Neil. 2006. *Camouflage*. Cambridge, Mass.: MIT Press.
- Madill, Shirley. 2006. *Sublime embrace : Experiencing consciousness in contemporary art*. Hamilton, ON: Art Gallery of Hamilton.
- Malathouni, Christina. 2007. 'Higher' being and 'higher' drawing. In *From models to drawings*, eds. Marco Frascari, Jonathan Hale, and Bradley Starkey, 168-177. New York: Routledge.
- Manning, Erin. 2009. *Relationscapes : Movement, art, philosophy*. Technologies of lived abstraction. Cambridge, Mass.: MIT Press.
- Massumi, Brian. 2002. *Parables for the virtual : Movement, affect, sensation*. Durham, N.C. ; London: Duke University Press.
- Merleau-Ponty, Maurice. 1962. *Phenomenology of perception*. London ; New York: Routledge.
- Moon, Karen. 2005. *Modeling messages : The architect and the model*. New York: Monacelli Press.
- Moure, Gloria, and Terence Riley. 2000. *Architecture without shadow*. Barcelona: Ediciones Polígrafa.
- Ovid, 43 B.C.-17 or 18 A.D., and Horace Gregory. 1958. *Metamorphoses*. New York: New American Library.
- Pérez Gómez, Alberto. 2006. *Built upon love : Architectural longing after ethics and aesthetics*. Cambridge, Mass.: MIT Press.
- Plath, Sylvia, and Ted Hughes. 1981. *Collected poems*. London: Faber & Faber.
- Pliny, the Elder, John Bostock, and Henry Thomas Riley. 1855. *Natural history of pliny*. London: H.G. Bohn.
- Reichardt, Rolf, and Deborah Louise Cohen. 1998. Light against darkness: The visual representations of a central enlightenment concept. *Representations* (61) (Winter): 95-148.
- Ritchie, Ian. 2007. The cuisine of making shelter. In *The architect, the cook, and good taste*, ed. Perta Hagen and Rolf Toyka, 146-151. Basel ; Boston: Birkhäuser.
- Scheer, Edward, ed. 2004. *Antonin artaud : A critical reader*. London ; New York: Routledge.
- Schlemmer, Oskar, and Karin Von Maur. 1972. *Oskar schlemmer*. London: Thames and Hudson.

- Schlemmer, Oskar, László Moholy-Nagy, Farkas Molnár, and Walter Gropius. 1961. *Theater of the bauhaus*. Middletown, Conn.: Wesleyan University Press.
- Schwartz, Hillel. 1996. *Culture of the copy : Striking likenesses, unreasonable facsimiles*. New York: Zone Books.
- Shahshahani, Suhayla. 2004. *Body as medium of meaning*. Münster: Piscataway, NJ: Lit ; Dist. in North America by Transaction Publishers.
- Silverman, Hugh J. 2000. *Philosophy and desire*. Continental philosophy. New York: Routledge.
- Smith, Elise Lawton, and Mrs Evelyn De Morgan. 2002. *Evelyn pickering de morgan and the allegorical body*. Madison, N.J. ; London: Fairleigh Dickinson University Press ; Associated University Presses.
- Soares, Valeska, Cildo Meireles, and Ernesto Neto. 2007. *Seduções : Valeska soares, cildo meireles, ernesto neto : Instalacoes = instalaciones = installations, june 9 - october 15, 2006, daros exhibitio*. Ostfildern, Germany: Zürich, Switzerland: Hatje Cantz ; Daros-Latinamerica AG.
- Sorensen, Roy A. 2008. *Seeing dark things : The philosophy of shadows*. New York: Oxford University Press.
- Starkey, Bradley. 2007. Post-secular architecture : Material, intellectual, spiritual models. In *From models to drawings*, eds. Marco Frascari, Jonathan Hale and Bradley Starkey, 231-241. New York: Routledge.
- Stoichita, Victor Ieronim. 1997. *Short history of the shadow*. London: Reaktion Books.
- Thrift, Nigel J. 2008. *Non-representational theory : Space, politics, affect*. London ; New York: Routledge.
- Tiffany, Daniel. 2000. *Toy medium : Materialism and modern lyric*. Berkeley ; London: University of California Press.
- Tymieniecka, Anna Teresa. 1985. *Poetics of the elements in the human condition*. Analecta husserliana ; v. 19,23,28. Dordrecht, Netherlands: D. Reidel Pub. Co.
- Vidler, Anthony. 1992. *Architectural uncanny : Essays in the modern unhomely*. Cambridge, Mass.: MIT Press.
- Vovolis, Thanos. 2003. The Voice and the Mask in Ancient Greek Tragedy. In *Soundscape : the school of sound lectures, 1998-2001*, eds. Larry Sider, Jerry Sider and Diane Freeman, 73-82. London ; New York: Wallflower Press.
- Warner, Marina. 2007. Darkness Visible. In *Cabinet* (24): 75-88.
- . 2006. *Phantasmagoria : Spirit visions, metaphors, and media into the twenty-first century*. Oxford ; New York: Oxford University Press.
- . 2002. *Fantastic metamorphoses, other worlds : Ways of telling the self*. Clarendon lectures in english literature ; 200. Oxford ; New York: Oxford University Press.
- Watts-Hughes, Margaret. 1914. Voice Figures. In *Voice buiding and tone placing*, 3rd ed., ed. Henry Holbrook Curtis, 217-232. New York: D. Appleton and Company.
- Woodman, Francesca, and Philippe Sollers. 1998. *Francesca woodman*. 1st Scalo ed. Zurich : Paris: Scalo ; Fondation Cartier pour l'art contemporain.
- Woolf, Virginia. 1978. *Waves*. San Diego: Harcourt Brace Jovanovich.
- Zaner, Richard M. 19uu. *Problem of embodiment; some contributions to a phenomenology of the body*. Phaenomenologica ; 1. The Hague: M. Nijhoff.

Experiencing

EXPERIENCING THE WORK

f.137

by Author 'Exhibition - Entrance off Main Street'



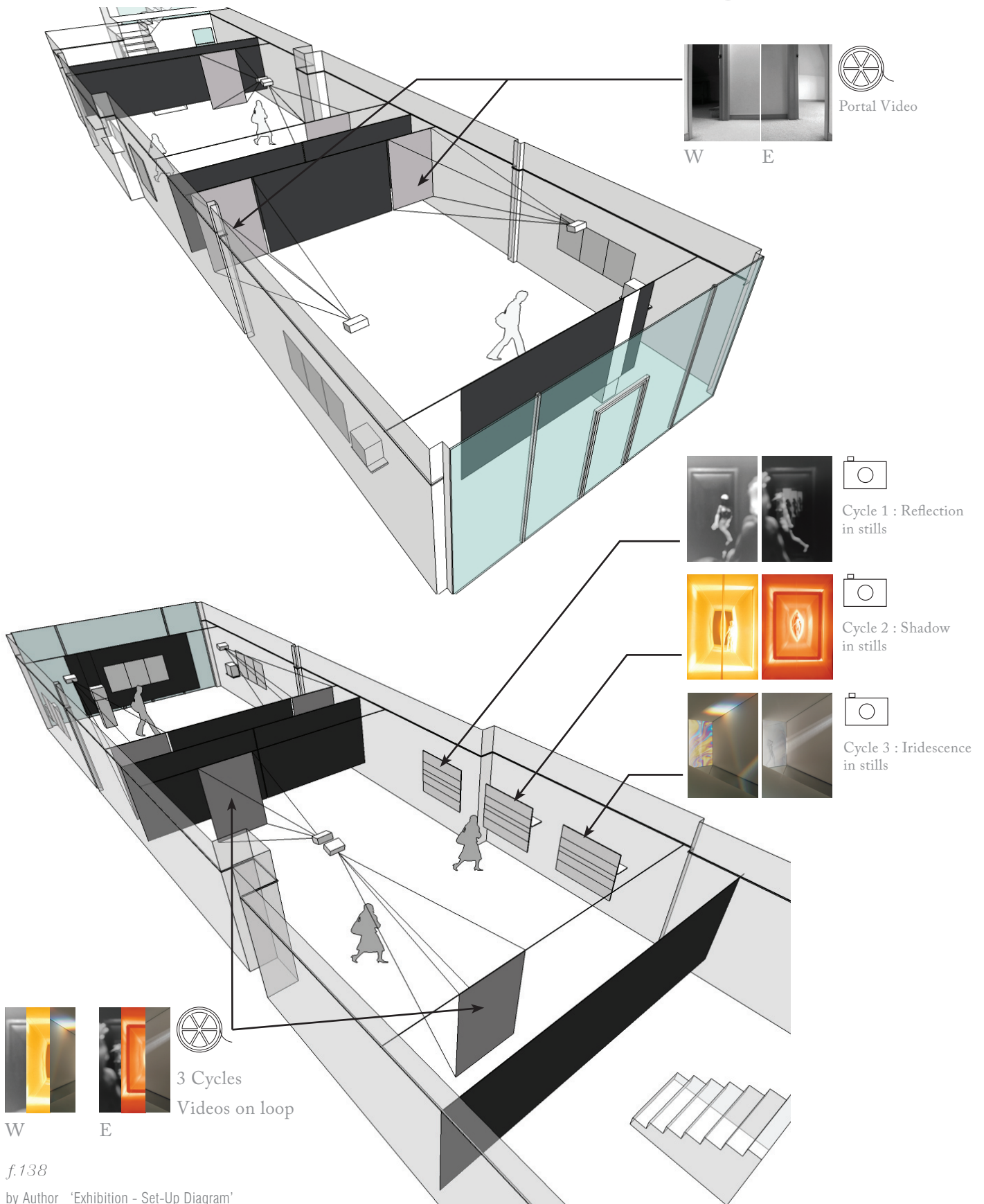

3 Cycles
Videos on loop

W

E

f.138

by Author 'Exhibition - Set-Up Diagram'



f.139
by Author 'Exhibition - Entrance Space 1'

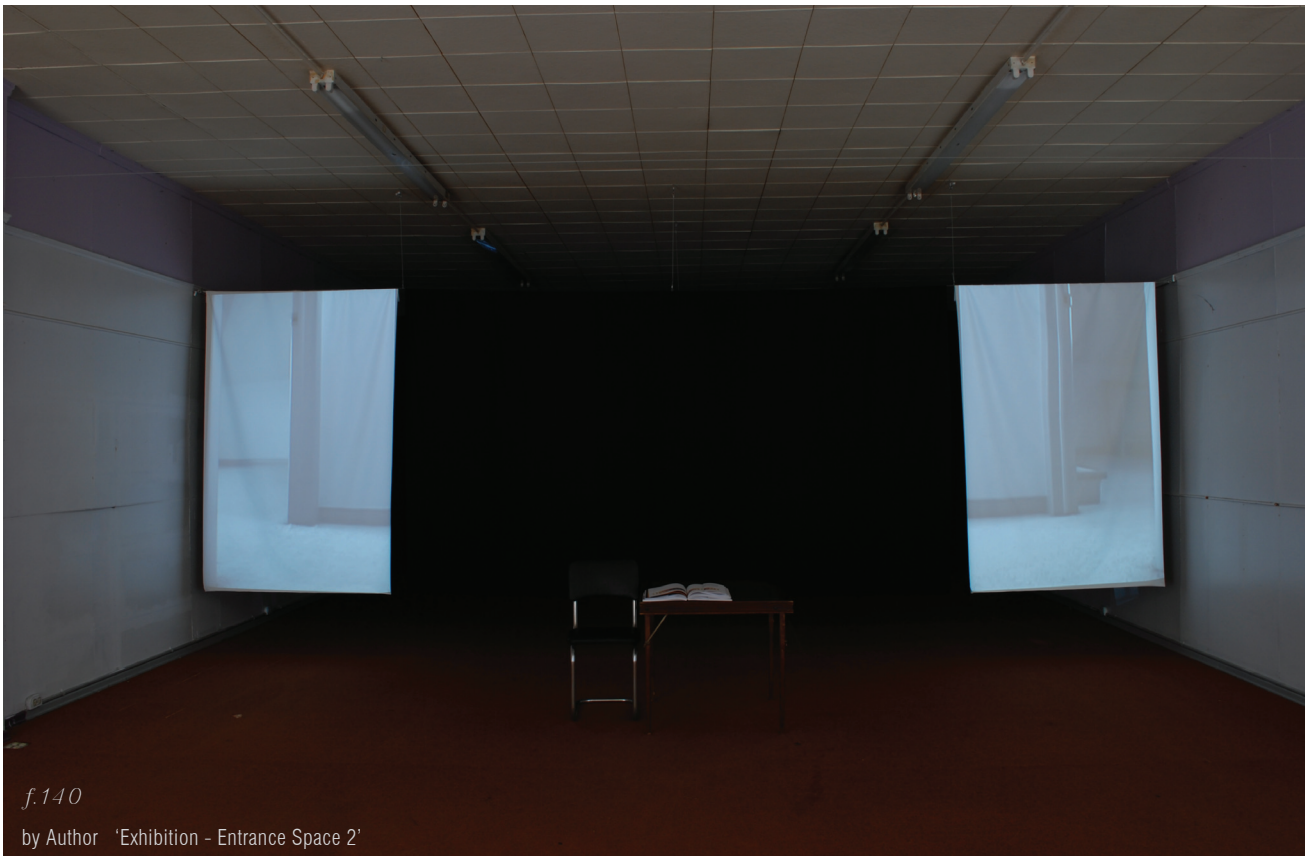

f.140
by Author 'Exhibition - Entrance Space 2'

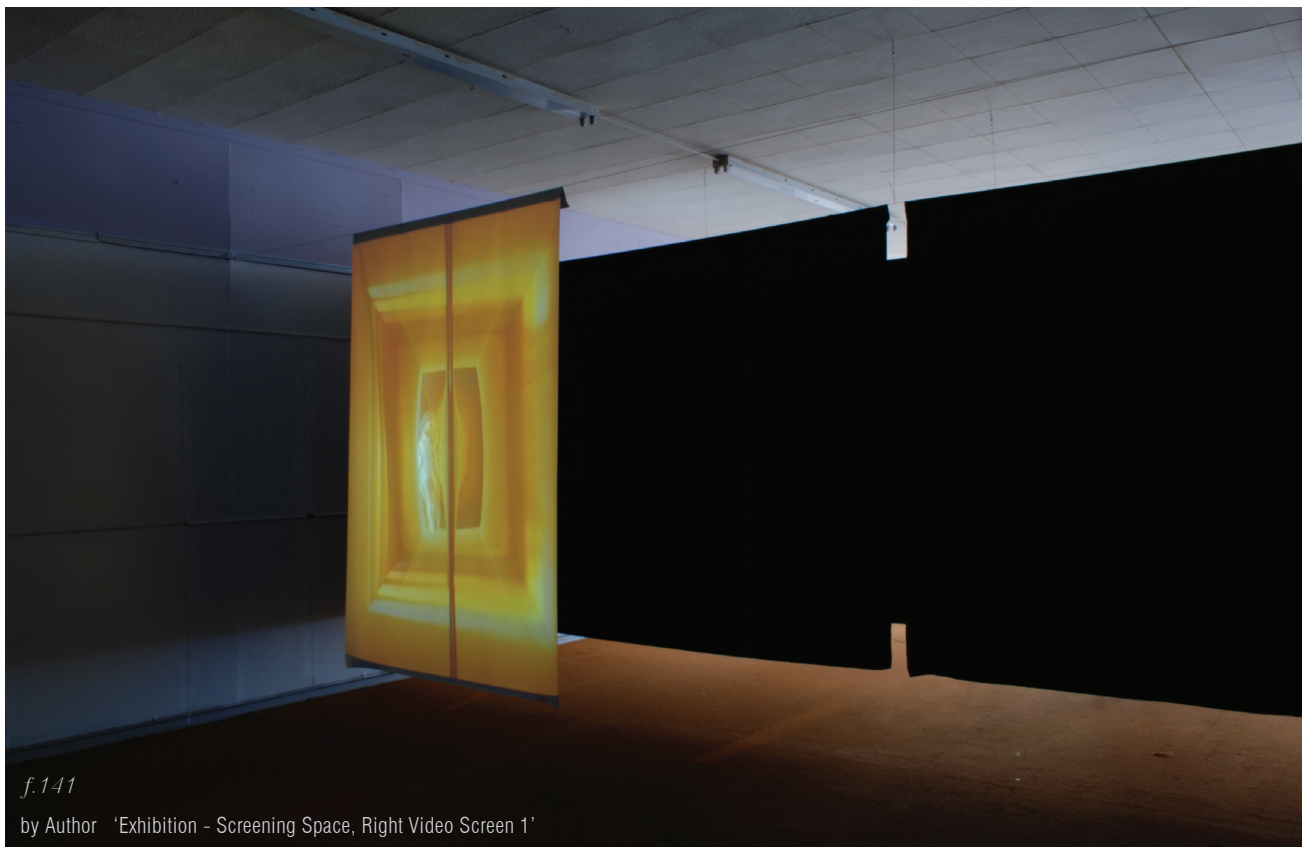

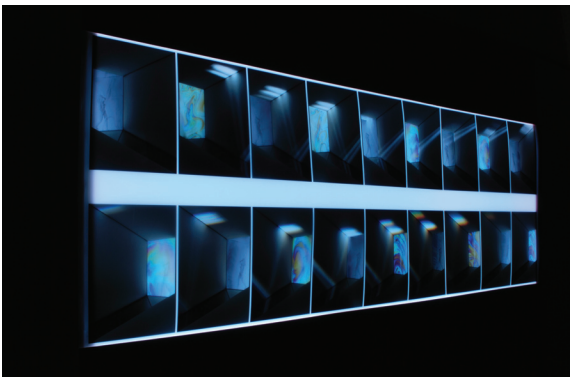
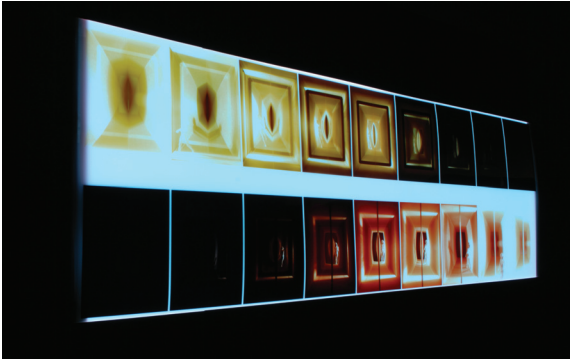
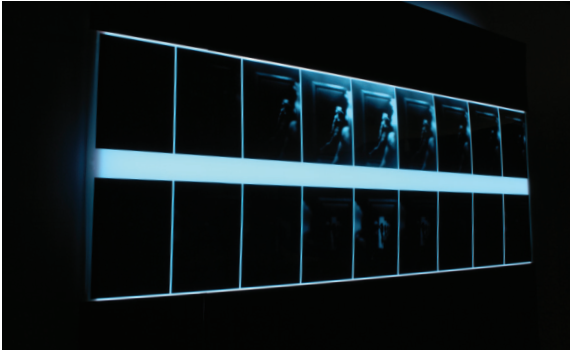

f.143

by Author 'Exhibition - Screening Space, Select Shots of Stills on Light Panels'

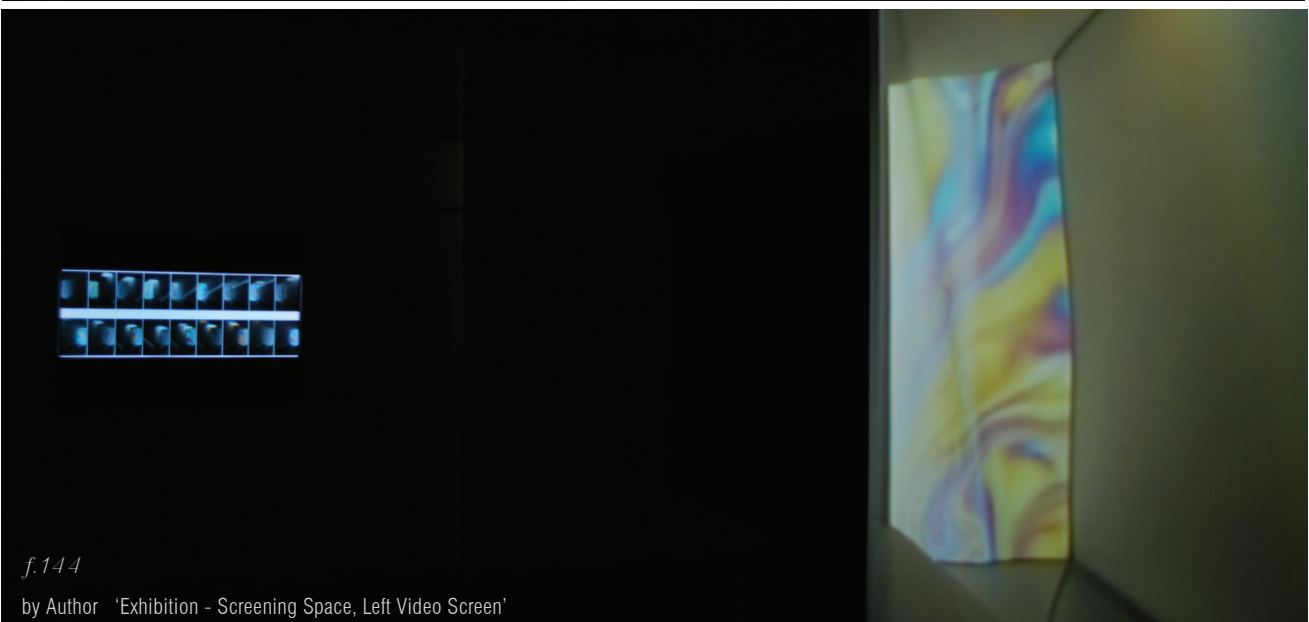

f.144

by Author 'Exhibition - Screening Space, Left Video Screen'