

**The North House as Responsive Architecture:
Designing for Interaction between Building, Inhabitant, and Environment**

by
Lauren Barhydt

A thesis
presented to the University of Waterloo
in fulfillment of the
thesis requirement for the degree of
Master of Architecture

Waterloo, Ontario, Canada, 2010
© Lauren Barhydt 2010

AUTHOR'S DECLARATION

I hereby declare that I am the sole author of this thesis. This is a true copy of the thesis, including any required final revisions, as accepted by my examiners.

I understand that my thesis may be made electronically available to the public.

ABSTRACT

The North House is a proof-of-concept prefabricated solar-powered home designed for northern climates, and intended for the research and promotion of high-performance sustainable architecture. Led by faculty at the University of Waterloo, the project was undertaken by Team North a broad collaboration between faculty and students at the Universities of Waterloo, Ryerson and Simon Fraser. In October 2009, the North House prototype competed in the U.S. Department of Energy's Solar Decathlon, where it placed fourth overall.

The North House addresses the urgent environmental imperative to dramatically reduce energy consumed by the built environment. It does so, in part by employing two primary technological systems which make use of feedback and response mechanisms; the Distributed Responsive System of Skins (DReSS) reconfigures the envelope in response to changing weather conditions, while the Adaptive Living Interface System (ALIS) provides detailed performance feedback to the inhabitant, equipping them with informed control of their home.

This thesis recognizes energy consumption as a socio-technical problem that implicates building inhabitants as much as buildings themselves. It also recognizes the particular potency of the 'house' as a building type that touches a broad population in a profoundly personal way; and is thus an apt testing ground for technologies that conserve energy, and those that teach occupants to do the same. With these ideas in mind, the thesis looks to Interactive Architecture - a practice that considers buildings and their inhabitants as an integrated system - as a promising conceptual framework for synthesizing the social and technical aspects of energy conservation in the home.

ACKNOWLEDGEMENTS

I would like to thank my supervisor, Geoffrey Thün, and the members of my committee, David Leiberman, Dr. John Straube, and Kathy Velikov, for the incredible opportunity to work on this project, for their assistance in the production of this document, and for their vision and support throughout the past two years. I would also like to thank my external examiner Dr. Catherine Burns for her insightful engagement with the work. Furthermore, I would like to acknowledge Andri Lima for her goodwill, advocacy and constant support for the all of the graduate students of architecture.

I am also grateful to the entire North House team, students, faculty, builders, and installers, who worked tirelessly and cheerfully to make this crazy dream a reality. I have learned so much from each of you, from your vast spectrum of knowledge and from your seemingly infinite reserves of kindness, patience, and fun.

For a full list of team members please see Appendix A: Team North Extended Credits.

DEDICATION

I would like to dedicate this thesis to the group of architectural graduate students with whom I have worked closely for a year and a half: Chris Black, Maun Demchenko, Chloe Doesburg, Natalie Jackson, Jen Janzen, and Bradley Paddock. Our experiences together were intense, and intensely rewarding. I treasure these memories, and your friendship.

To my family, Monica, Peter, and Luke, who have always offered unwavering love and enthusiastic support. I am so lucky to be one of you.

To Jonathan, thank you for your love and patience. You challenge and inspire me.

And lastly, to my Granny, a force of nature and a tremendous source of inspiration, who I love and miss dearly.

CONTENTS

Author's Declaration	ii
Abstract	iii
Acknowledgements	iv
Dedication	v
List of Figures	xi
Introduction	
Introducing The North House	1
Introducing The Solar Decathlon	9
Situating the Thesis	13
Part 1: Interactive Architecture as a Strategy for Promoting Sustainable Inhabitation	17
Part 2: Environmental Responsiveness and Energy Efficient Systems	37
The Design and Integration the Distributed Responsive System of Skins	
2.1 Design Process: Parallel development of North House and DReSS as a feedback based process	37
2.1.1 Design Objectives and Constraints	38
2.1.2 Design Integration	41
2.2 Layers of the DReSS and the Insulated Envelope	54
2.2.1 Insulated Envelope Assembly	54
2.2.2 Building Integrated Photovoltaics	55
2.2.3 Exterior Shades	55
2.2.4 Insulated Glazing Unit and Wood Frame	56
2.2.5 Phase Change Materials	57
2.2.6 Interior Layers – Roller Blinds and Ceiling Panels	58
2.3 Integrated Control Strategy	59
2.3.1 Integrated Active and Passive Thermal Management	59
2.3.2 HVAC and Domestic Hot Water Operation and Control	61
2.3.3 Exterior Shade Operations and Control	65
2.4 North House Energy Balance	72
2.5 Architectural Expression and Occupant Experience	75

Part 3: Inhabitant Responsiveness and Sustainable Lifestyles	
The Design and Integration of the Adaptive Living Interface System and the Central Home Automation System	85
3.1 Industry Review of In-Home Graphical User Interface Systems	85
3.2 Understanding the Inhabitant	87
3.3 Design Principles	88
3.4 The Adaptive Living Interface System	93
3.5 The Central Home Automation Server	108
Conclusion	115
Bibliography	121
Appendix A: Team North Extended Credits	127

LIST OF FIGURES

Pg.	Fig.	Description and Source
-----	------	------------------------

Introduction

xviii	0.1	North House during Solar Decathlon 2009 photo by Geoffrey Thün, courtesy of Team North
2	0.2	North House floor plan courtesy of Team North
3	0.3	Rendering of North House in a Canadian winter landscape image by Lindsey Nette and David Schellingerhoudt, courtesy of Team North
4	0.4	Exploded axonometric of DReSS image by Lindsey Nette and David Schellingerhoudt, courtesy of Team North
5	0.5	Plan locating ALIS within North House diagram by author, courtesy of Team North
6	0.6	Exploded axonometric of North House construction components drawing by Chloe Doesburg, courtesy of Team North
8	0.7	Aerial view of the 2009 Solar Decathlon Competition on the National Mall, Washington DC photo from Solar Decathlon website: Solar Decathlon 2009 High-Resolution Photos of the Day http://www.solardecathlon.gov/past/2009/daily_photos.cfm (accessed 10.05.13)

Pg.	Fig.	Description and Source
-----	------	------------------------

Part I

18	1.1	Graph of the energy consumption by sector image from Architecture 2030 website: The Building Sector: A hidden culprit http://www.architecture2030.org/current_situation/building_sector.html (accessed 10.05.13)
20	1.2	Interior perspective of The Fun Palace drawing by Cedric Price from Canadian Centre for Architecture: Cedric Price: Fun Palace Collection http://www.cca.qc.ca/en/collection/283-cedric-price-fun-palace (accessed 10.05.13)
21	1.3	The Cushicle and Suitaloon drawing by Michael Webb from The Archigram Archival Project http://archigram.westminster.ac.uk/project.php?id=92 (accessed 10.05.13)
22	1.4	Open Columns by Omar Kahn photo from flickr, posted by Liminal Projects http://www.flickr.com/photos/liminalprojects/sets/72157602082062155/ (accessed 10.05.13)
22	1.5	P2P: Power to the People by Gorbet Design photo from Gorbet Design Inc. website: http://www.gorbetdesign.com/proj_p2p.html (accessed 10.05.13)
27	1.6	Still image from the movie Brazil photo from the Internet Movie Database http://www.imdb.com/media/rm2216466432/tt0088846 (access 10.05.10)

Pg.	Fig.	Description and Source	Pg.	Fig.	Description and Source
		Part 2			
36	2.0	Exploded axonometric of DReSS image by Lindsey Nette and David Schellingerhoudt, courtesy of Team North	49	2.10	Exploded axonometric of North House early design iteration (June 2008) image by RVTR, courtesy of Team North
41	2.1	Graph from ESP-r energy simulation of North House by Bartosz Lomanowski, courtesy of Team North	50	2.11	Exploded axonometric of North House design iteration (December 2008) image by Chloe Doesburg, courtesy of Team North
42	2.2	Comparison of priority glazing types by Ivan Lee and Bartosz Lomanowski, courtesy of Team North	51	2.12	Early design iteration of North House image by Eric Bury, PBAi, courtesy of Team North
43	2.3	Volumetric diagram of building energy simulations courtesy of Team North	51	2.13	Early design iteration of North House image by Eric Bury, PBAi, courtesy of Team North
43	2.4	Volumetric diagram of building energy simulations courtesy of Team North	51	2.14	Design iteration of North House image by Eric Bury, PBAi, courtesy of Team North
43	2.5	Plan diagram of early design iteration by RVTR, courtesy of Team North	52	2.15	Floor Plan, Construction Documents courtesy of Team North
44	2.6	Montage of exterior shading device design investigations montage by author, images by Eric Bury, Philip Beesley Architect Inc., courtesy of Team North	53	2.16	Typical Wall Section, drawing by Chloe Doesburg, from The North House as Component Based Architecture, Thesis document
46	2.7	Visualization of PV array design investigations montage by author, images by Matt Peddie, RVTR, courtesy of Team North	54	2.17	Graph of hygrothermal performance of wall assembly by Ivan Lee, courtesy of Team North
47	2.8	Graph from TRNSYS energy simulation of North House by Sebastien Brideau and Andrew Marston, courtesy of Team North	54	2.18	Roof panel assembly courtesy of Team North
48	2.9	Exploded axonometric of North House early design iteration (November 2007) image by RVTR, courtesy of Team North	55	2.19	BIPV and exterior shades photo by Andrea Hunniford, courtesy of Team North
			56	2.20	Layers of the Insulated Glazing Unit courtesy of Team North

Pg.	Fig.	Description	Pg.	Fig.	Description
56	2.21	Detail at window mullion courtesy of Team North	68	2.33	Exterior shades control states image author, adapted from diagram by Kush Bubbar, courtesy of Team North
57	2.22	Installation of PCM photo by Chloe Doesburg, courtesy of Team North	70	2.34	Exterior shades range of configurations image by Lindsey Nette and David Schellingerhoudt, modified by author, courtesy of Team North
58	2.23	Interior blinds and ceiling panels photo by Geoffrey Thün, courtesy of Team North	73	2.35	Graph of ESP-r building energy simulation courtesy of Team North
58	2.24	Interior ceiling panels photo by Matt Peddie, courtesy of Team North	73	2.36	Graph of building energy balance courtesy of Team North
59	2.25	Shade and HVAC state diagram image by author, adapted from diagram by Brent Crowhurst, courtesy of Team North	74	2.37	Interior view photo by Geoffrey Thün, courtesy of Team North
60	2.26	Mechanical system control diagram image by author, courtesy of Team North	74	2.38	Interior view photo by Geoffrey Thün, courtesy of Team North
62	2.27	Configuration and operation of the mechanical system - heating image by author, courtesy of Team North	76	2.39	Interior view photo by Geoffrey Thün, courtesy of Team North
63	2.28	Custom component details image by author, courtesy of Team North	76	2.40	Interior view photo by Geoffrey Thün, courtesy of Team North
64	2.29	Configuration and operation of the mechanical system - cooling image by author, courtesy of Team North	78	2.41	Exterior view photo by Geoffrey Thün, courtesy of Team North
66	2.30	Exterior shade control diagram image by author, courtesy of Team North	78	2.42	Exterior view photo by Matt Peddie, courtesy of Team North
67	2.31	Interior corner detail of glazing and shades photo by Terry Meyer Boake	80	2.43	Exterior view photo by Matt Peddie, courtesy of Team North
67	2.32	Daylight condition in kitchen photo by Matt Peddie, courtesy of Team North	80	2.44	Interior view photo by Geoffrey Thün, courtesy of Team North

Pg.	Fig.	Description
		Part 3
84	3.0	Rendering of North House interior with ALIS image by Lindsey Nette and David Schellingerhoudt, courtesy of Team North
86	3.1	Screenshot of Agile Waves GUI image from Agile Waves website http://www.agilewaves.com/ (accessed 10.05.10)
86	3.2	Owl Ecosavers Energy Meter image from Ethical Superstore website http://www.ethicalsuperstore.com/products/ecosavers/ecosavers-energy-meter/ (accessed 10.05.10)
89	3.3	Graphic control elements image by Kevin Muise, courtesy of Team North, modified by author
90	3.4	Partial screenshot of ALIS web application image by Kevin Muise, and Johnny Rodgers, courtesy of Team North
92	3.5	Partial screenshot of ALIS web application image by Kevin Muise and Johnny Rodgers, courtesy of Team North
93	3.6	Montage of screenshot of ALIS iphone web application images by Kevin Muise and Johnny Rodgers, courtesy of Team North
94	3.7	The ambient canvas image by Lindsey Nette and David Schellingerhoudt, courtesy of Team North
95	3.8	Plan locating ALIS within North House diagram by author, courtesy of Team North

Pg.	Fig.	Description
96	3.9	Navigational hierarchy of the control panel GUI diagram by Kevin Muise and Johny Rodgers, modified by author, courtesy of Team North
97	3.10	Screenshot of Control Panel GUI image by Kevin Muise and Johnny Rodgers, modified by author, courtesy of Team North
98	3.11	Navigational hierarchy of the ALIS web-Application diagram by Kevin Muise and Johnny Rodgers, modified by author, courtesy of Team North
100	3.12	Screenshot of ALIS web-application image by Kevin Muise and Johnny Rodgers, modified by author, courtesy of Team North
101	3.13	Screenshot of ALIS web-application image by Kevin Muise and Johnny Rodgers, modified by author, courtesy of Team North
102	3.14	Screenshot of ALIS web-application image by Kevin Muise and Johnny Rodgers, modified by author, courtesy of Team North
102	3.15	Screenshot of ALIS web-application image by Kevin Muise and Johnny Rodgers, modified by author, courtesy of Team North
104	3.16	Screenshot of ALIS web-application image by Kevin Muise and Johnny Rodgers, modified by author, courtesy of Team North
105	3.17	Screenshot of ALIS web-application image by Kevin Muise and Johnny Rodgers, modified by author, courtesy of Team North

Pg.	Fig.	Description
106	3.18	Screenshot of ALIS web-application image by Kevin Muise and Johnny Rodgers, modified by author, courtesy of Team North
107	3.19	Screenshot of ALIS web-application image by Kevin Muise and Johnny Rodgers, modified by author, courtesy of Team North
110	3.20	Overview of the CHAS and ALIS control system image by author, courtesy of Team North



INTRODUCING THE NORTH HOUSE

The North House is a proof-of-concept prefabricated solar-powered home designed for northern climates, and intended for the research and promotion of high-performance sustainable architecture. The project was initiated in the fall of 2007 by Professors Geoffrey Thün and Kathy Velikov at the University of Waterloo School of Architecture. The development and design of the project was undertaken by Team North, a broad collaboration between faculty and students at the Universities of Waterloo, Ryerson and Simon Fraser. This thesis originates from this faculty-directed research project for which I was a primary member of the graduate student team. Many of the concepts and details described in this work were developed by the team in the greater context of the project; however, the research and discussion of the implications of responsive design in service of the goals of sustainability, as well as the production of the descriptive text and illustrations of the responsive systems developed for North House, are representative of the unique contributions that I have made to the larger project.

The house was designed as a public demonstration project with a focus on high-performance architecture, responsive systems, and interactive technologies. It showcases a wide range of new applications of technology and promotes an energy conscious way of living. It was also intended for use as a research laboratory, for the long-term monitoring of the systems in the house, and to accommodate the installation and testing of subsequent iterations of its systems and components. The house was fabricated by MCM 2001 Inc., a custom millwork and components manufacturer located in Toronto, Ontario. During fabrication Professor David Lieberman played a key role in project refinement and completion.

The North House was one of twenty projects selected as finalists in the 2009 Solar Decathlon, sponsored by the United States Department of Energy (DOE) and the National Renewable Energy Laboratory (NREL). All twenty

Facing Page
Figure 0.1: View of North House on the
National Mall, Washington D.C. Solar
Decathlon 2009

houses were erected on the National Mall in Washington, D.C. during the month of October 2009, where they competed against one another in ten specific contests structured to both qualitatively and quantitatively assess their design and performance, including Architecture, Engineering, Lighting Design, Market Viability, Communications, Comfort Zone, Hot Water Production, Appliances, Home Entertainment, and Net Metering. North House placed fourth overall in the competition.

The house is organized into two basic zones. The first is a highly insulated north service zone, referred to as the 'densepack', which constitutes the building's primary structural module and contains all mechanical and electrical components, wet services and storage. The second zone is an open flexible and reconfigurable living and sleeping space, clad on three sides in the DReSS layered façade system which partners large areas of glazing with dynamically controlled exterior shading.

DESIGN OBJECTIVES

Five design objectives were established by the team at the outset of the North House project and remained consistent throughout the 18 month design and construction process. These objectives were: 1) Build a high-performance house for the extremes of the Canadian climate, 2) Design an envelope system that responds to changing conditions by distributing functions across a layered system of skins, 3) Provide an interface between inhabitant and building technology that allows them to operate the complex technologies easily and intelligently, 4) Design an interior and exterior domestic environment that encourages inhabitants to live in tune with solar and seasonal cycles, and 5) Develop a suite of building components that anticipate the potential for mass fabrication and mass customization, while meeting the particular logistical requirements of the Solar Decathlon competition.

These design objectives were discreet in their conception, though throughout the design process, each decision was made considering all of the stated objectives, resulting in an integrated design that is now difficult to parse according to original intent. For example, the first objective of designing for Canadian climate extremes determined the specific characteristics and operations of the layered building envelope known as the Distributed Responsive System of Skins (DReSS) as well as the mechanical conditioning system. The technologies of the DReSS and mechanical conditioning system, in turn, determined the precise specifications for the control and monitoring

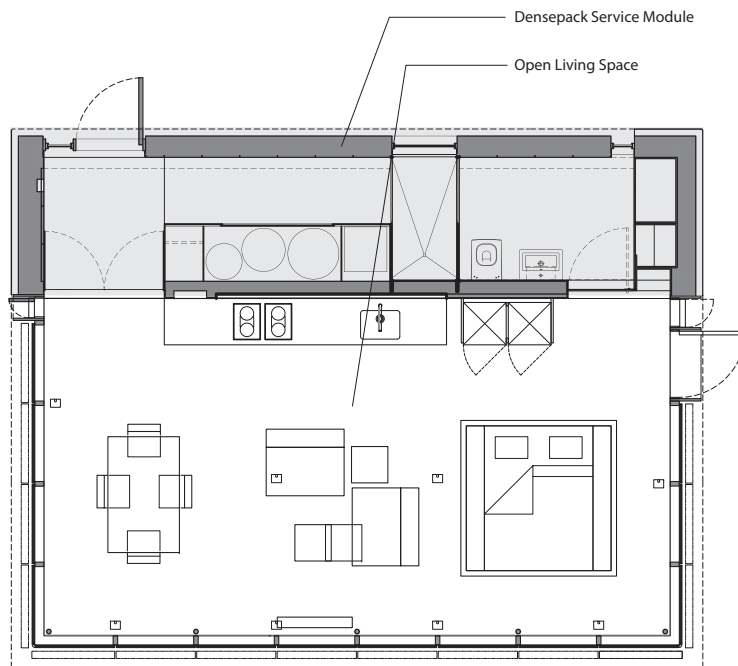

Figure 0.2: Floor Plan of North House

system known as the Adaptive Living Interface System (ALIS). Each of these technologies is also designed to be compatible with the component based pre-fabrication strategy. Furthermore, all of the technologies and building components are integrated into a domestic environment, with a highly refined aesthetic, aimed at supporting a comfortable and sustainable lifestyle with maximal engagement to the exterior landscape and the seasonal cycles.

These design objectives and their manifestations in the built project are described in more detail below.

A House for Climate Extremes

Beyond simply designing for a cold climate, North House was also required to perform in extreme climate fluctuations, such as that of Southern Ontario, where it is common to experience hot, humid summers and cold, dry winters, ranging between +30°C and -15°C¹ as well as shoulder seasons with quick and frequent fluctuations between the two extremes. The house is designed to respond quickly to these fluctuations using a layered façade system called the DReSS, outlined below. The power generating elements of the house comprise a set of technologies which are also intended to perform in these extreme conditions. While horizontally mounted photovoltaic panels on the roof perform optimally in the summer, vertically mounted building-integrated photovoltaic panels on south, east, and west façades perform well in winter when sun angles are low. These arrays are grid tied as per competition requirements. In total, they constitute a 14kW solar array which, over the course of an annual cycle, will produce almost twice the energy that the house consumes. Solar thermal collectors on the roof provide hot water for domestic use and space heating through a three-tank cascading-heat system. Insulated casement panels open to provide passive ventilation when exterior temperatures are appropriate and maintain the integrity of the thermal envelope when closed.

Distributed Responsive System of Skins (DReSS)

DReSS is a suite of layered building envelope components in which each layer performs a specific function while contributing to an overall system that responds dynamically to changes in exterior environmental conditions, the interior temperature and humidity, and the occupants' desired configuration. The ratio of solid insulated wall assembly to DReSS was carefully balanced using energy modeling software in order to maximize passive heating capacity while providing adequate thermal retention. The layers of the DReSS include:



Figure 0.3: Rendering of the North House in a Canadian winter landscape

automated exterior shades; high performance glazing in a custom designed wood curtain-wall system; motorized interior blinds; and Phase Change Material (PCM) under the finished floor. The DReSS makes use of passive solar principles, but eliminates the burdensome responsibility on the occupant by actively responding to changing exterior conditions.

The primary shading devices are located on the outside of the envelope so that they can block solar radiation before it reaches the glazing, virtually eliminating unwanted solar gain. Alternately, when heating is needed, the shades can be fully retracted to maximize solar gain. Between these two extreme operational states, the shades are capable of maintaining the interior temperature by alternating between positions that are parallel or perpendicular to the sun's rays. Salt hydrate Phase Change Material (PCM), encapsulated in plastic panels that are installed beneath the finished floor, moderates the interior temperature, capturing excess heat throughout the day, and releasing it at night as the interior cools. The control system for the shades was developed by the project team to outperform existing manufacturer controls which merely reject solar heat gain, rather than harvesting it when it is useful. Standard control software operates the shades at predetermined states based on typical weather patterns for a given geographic location. The North House shade control system monitors solar irradiance, wind speeds, and interior temperatures to determine the appropriate shade configuration to maintain the desired interior temperature. Façades that are not receiving direct sunlight remain open, maximizing daylight and unobstructed views to the exterior.

The insulated glazing units (IGUs) were selected to balance the admission of solar gain with the retention of heat and to maintain a high visual clarity. The IGUs have an R-value of 12 (U-value of 0.472), a Solar Heat Gain Coefficient of 0.438 and a Visual Transmittance value of 0.585. They use semi-insulating spacers which balance R-value and the necessary structural capacity to make the manufacture of large high-performance units possible. The IGUs are quadruple-layered with two mylar films suspended between two panes of glass. A low emissivity (low-e) coating is applied to the exterior facing surfaces of glass and mylar films to control radiant heat. The interior cavities are krypton filled to achieve a high insulation value. The wood curtain wall system is designed to avoid thermal transmission by using rubber caps anchored to a friction-fit clip pre-installed on the face of the mullion. Large IGUs in combination with the wood curtain wall system minimizes the 'frame effect' where heat is typically lost primarily through the edges of the IGUs.

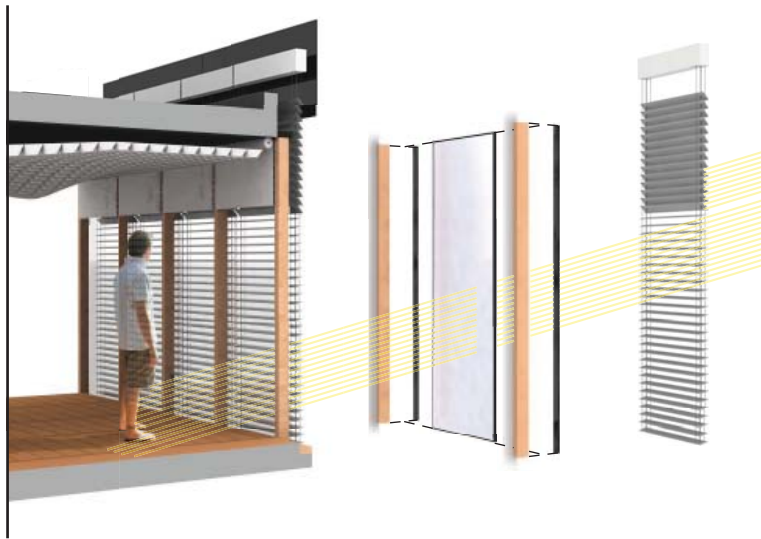

Figure 0.4: Exploded axonometric rendering of the Distributed Responsive System of Skins (DReSS)

The interior blinds can be individually controlled to provide privacy and reduce glare. They allow the occupants to control their environment in a way that will not compromise the energy performance of the building envelope.

Adaptive Living Interface System (ALIS)

The Adaptive Living Interface System is a digital interface through which inhabitants can control and monitor the active systems within the North House. Three wall-mounted touchscreens allow for intuitive control of lights, shades, blinds, and interior climate. The interface provides direct feedback on energy consumption relative to the inhabitants' decisions and habits. These same controls and accompanying performance feedback can be accessed online or through a smart phone, providing maximum flexibility to the occupants. This web-application also connects inhabitants to a social network of energy aware individuals, which further encourages sustainable lifestyle choices through friendly competition, knowledge sharing, and opening other opportunities for sharing resources.

Another feature of the ALIS is the 'ambient canvas' an LED display embedded in the kitchen backsplash which is visible from all part of the living space. The intensity of the light varies to subtly inform inhabitants of their energy and water consumption as well as their progress toward predetermined goals. This strategy of providing always-present, but unintrusive, ambient feedback is linked to psychological research which suggests that subconscious, non-information based cues form a critical dimension in guiding behavior.² The combination of detailed informational feedback with always-present ambient cues empowers inhabitants with alertness to their overall consumption patterns and detailed understanding of the consequences of their everyday activities.

Holistic Solar Living

The ambition of Holistic Solar Living is to incorporate solar resources into inhabitant lifestyles in ways much broader than simple power generation. Many aspects of the North House design encourage a lifestyle which varies with the seasons. Daylighting and visual connections to the outdoors are maximized, especially in colder months when occupants tend to spend less time outdoors. In warmer months, the occupants of North House can enjoy a range of outdoor amenities supported by a generous landscape, with space for dining and entertaining, vegetable gardens for food production, and an extensive outdoor counter with a sink, for canning or drying food

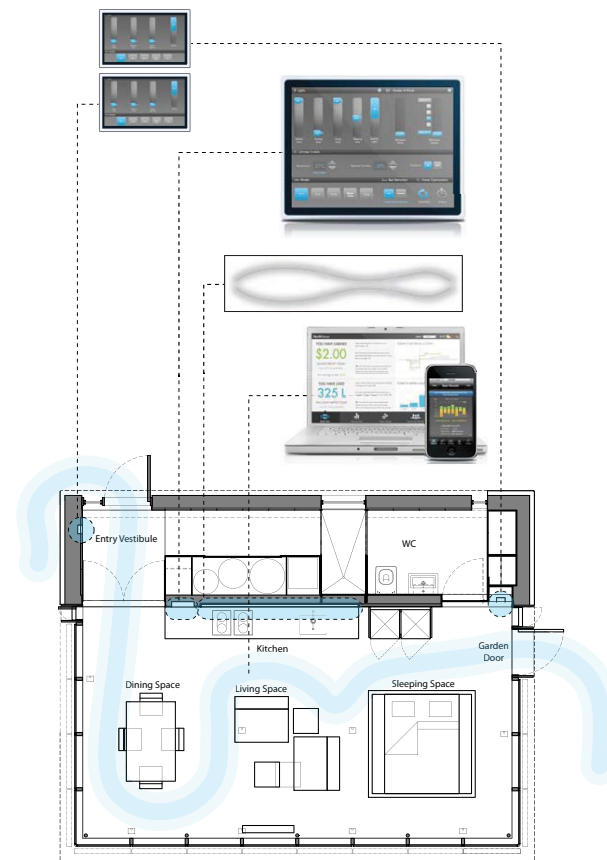

Figure 0.5: Plan locating access to the Adaptive Living Interface System in North House

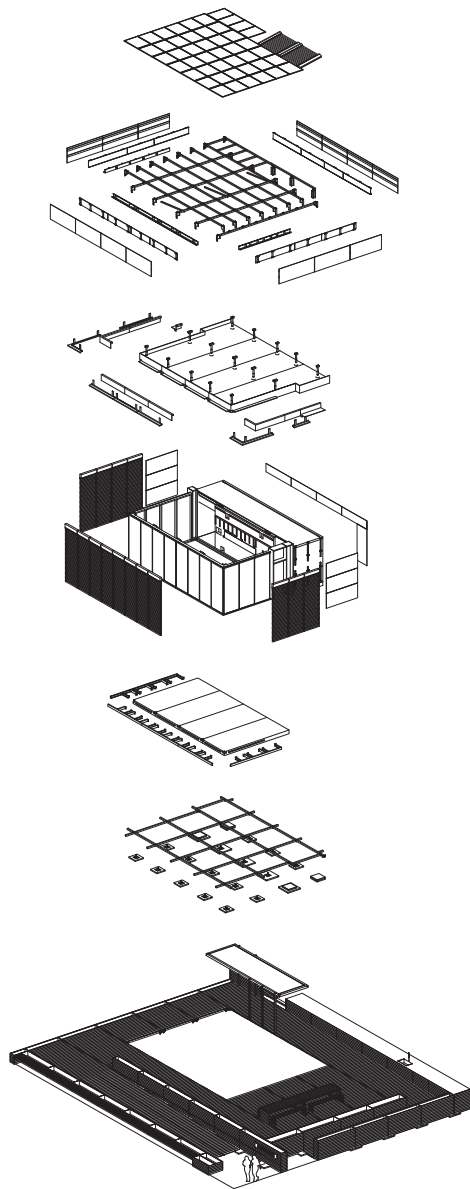

Figure 0.6: Exploded Axonometric showing primary components of North House

grown on site. Throughout the seasons, the interior space of the home is visually characterized by the operations of the DReSS which also serves to ambiently communicate the energy flows between exterior and interior. All of these factors encourage the occupants of North house to vary their lifestyle according to solar and seasonal conditions.

Customizable Components

North House is a prefabricated, factory-built housing prototype, which is assembled from independently constructed components. The project was designed anticipating the potential for mass production and mass customization, insofar as its components might be reconfigured to produce a range of housing types and sizes. Individual components are designed for ease of assembly and disassembly, and so that individual components or entire systems can be removed and replaced by alternates. Chloe Doesburg's thesis, *North House as Component Based Architecture*, presents a detailed description of components, assembly details, and construction strategy.

Although the prototype is designed for two occupants, this is not intended to declare an optimal final design solution, but is rather a vehicle for testing the component assemblies and systems. It is conceived of as a test-case that would inform further development of marketable products. The possibility of reconfiguring components, and testing alternative systems was explored through the Latitude Housing System³ developed by RVTR in parallel with North House.

This thesis focuses primarily on the manifestations of two of the above design objectives: the DReSS and the ALIS. These two objectives generated a suite of technologies that incorporate mechanisms of feedback from the interior environment, the exterior environment, and the inhabitant. Taken together, these two systems present an interesting case for harnessing responsive architecture to address energy consumption in buildings from both a social and technical perspective.

- 1 Weatherbase: Historical Weather for Toronto, Ontario. Weatherbase Toronto, Ontario. <http://www.weatherbase.com/weather/weather.php?s=042617&refer=> (accessed Jan 24, 2010)
- 2 Kathy Velikov and Lyn Bartram. North House: Developing Intelligent Building Technology and User Interface in Energy Independent Domestic Environments. Presented at the Passive and Low Energy Architecture Conference PLEA 2009: Architecture, Energy and the Occupant's Perspective. June 22-24 2009. Quebec City.
- 3 Georgina Foley and Living Steel. Houses of Steel: Living Steel's international architecture competitions. Mulgrave, Vic: Images Publishing, 2009.



INTRODUCING THE SOLAR DECATHLON

The Solar Decathlon is a biannual competition hosted by the United States Department of Energy and the National Renewable Energy Laboratory. In the 2009 competition, twenty teams were selected as finalists from a range of international applicants. Each team designed and built a 100% solar-powered house which was transported to Washington, DC and assembled on the National Mall over a period of seven days. Once assembled, the 20 solar houses were open to public tours for ten days, during which they were toured by 2000 – 4000 visitors per day. Throughout the public touring period, teams competed in ten specific contests structured to both qualitatively and quantitatively assess their design and performance, including Architecture, Engineering, Lighting Design, Market Viability, Communications, Comfort Zone, Hot Water production, Appliances, Home Entertainment, and Net Metering. At the end of the competition period, teams had a final three days to disassemble their house.

Several thematic similarities emerged among the twenty competing houses due to the combination of several highly specific constraints: the competition rules; the restrictions of building on the National Mall; the logistical requirements of assembling a functional building in seven days; and the added dimension of being a highly trafficked public exhibit. Prefabricated, dismountable building techniques were a natural design response based on the temporary nature of the installation. Flexible living spaces with reconfigurable furniture were also a commonly used strategy for addressing the 800sf (exterior dimension) floor plan limitation.

The North House Distributed Responsive System of Skins (DReSS) and Adaptive Living Interface System (ALIS) also shared some similarities to systems employed by other Solar Decathlon teams. Sophisticated control and energy monitoring systems were fairly common to the 20 solar houses in the 2009 Solar Decathlon, though this seemed to be a new trend since

Facing Page
Figure 0.7: Aerial view of the Solar Decathlon
2009 Solar Village

Goals of the Solar Decathlon¹:

1. To educate the student participants—the “decathletes”—about the benefits of energy efficiency, renewable energy and green building technologies. As the next generation of engineers, architects, builders, and communicators, the decathletes will be able to use this knowledge in their studies and their future careers.
2. To raise awareness among the general public about renewable energy and energy efficiency and how solar energy technologies can reduce energy use.
3. To help solar energy technologies enter the marketplace faster. This competition encourages the research and development of energy-efficiency and energy production technologies.
4. To foster collaboration among students from different academic disciplines—including engineering and architecture students, who rarely work together until they enter the workplace.
5. To promote an integrated or “whole building design” approach to new construction. This approach differs from the traditional design/build process because the design team considers the interactions of all building components and systems to create a more comfortable building, save energy, and reduce environmental impact.
6. To demonstrate to the public the potential of zero-energy homes, which produce as much energy from renewable sources, such as the sun and wind, as they consume. Even though the home might be connected to a utility grid, it has net zero energy consumption from the utility provider.

the previous competition in 2007. This trend points to both an increase of available technologies for these systems and a consistent pre-occupation with empowering the user with informed control of their energy consumption patterns. Though it was a common feature of many houses, the North House user control and monitoring system was the most extensive in the degree of control, the resolution of feedback data, and the variety of features and media employed in the system.

Operable envelope systems were also present to some degree among the other teams. Many teams invested substantial effort in developing high-performance windows and embedding phase-change materials in various parts of the envelope. At least one other team, Team Alberta, also applied automated exterior venetian blinds to their south facing windows. However, the North House’s DReSS was the unique application of actively managed passive solar design, in which solar heat gain could be precisely controlled and both harvested or rejected as needed.

- 1 U.S. Department of Energy: Solar Decathlon, “About Solar Decathlon,” <http://www.solardecathlon.org/about.cfm> (accessed April 13, 2010).

SITUATING THE THESIS

This thesis is positioned within the context of a faculty led research project that I worked on from February 2008 to October 2009, in the role of Project Manager. Under the supervision of Professor Thün, I was responsible for overseeing and coordinating all of the various efforts undertaken by the five faculties within the three participating Universities as well as numerous engineering, construction, and trade consultants, throughout all phases of development. Throughout the design and construction phases, my work focused heavily on negotiating the divergent needs of the many technical systems and integrating them with the architectural ambitions. Throughout the project, I was also involved in marketing, fundraising and sponsorship, media activities, recruitment campaigns, and liaising with administrative and regulatory organizations.

The work presented in this thesis was produced after the completion of the Solar Decathlon installation, and although it synthesizes work developed by the larger team, I produced it as a critical positioning of the design ambitions and a terminal record of the implemented systems.

Part 1: The Design Paradigm of Interactive Architecture as a Strategy for Promoting Sustainable Use of Buildings locates the North House within the emerging practice of high-performance building design and the paradigm of interactive architecture. This essay frames energy consumption as a socio-technical problem that implicates building inhabitant behaviour as much as building technologies, and therefore demands design solutions that consider both the technical and the social dimension of energy consumption. The essay then argues that feedback mechanisms are important and effective tools for integrating the social and technical considerations of the design and operation of energy efficient buildings. It specifically discusses the forms of feedback that are employed in North House through the DReSS and ALIS: feedback *to the inhabitant* through performance data delivered both

quantitatively and qualitatively; feedback *from the inhabitant* through extensive control of the building; feedback *from the interior and exterior environment* through climatically responsive building technologies; and feedback *from the community* of green building inhabitants. This essay expands on ideas that were present throughout the design of the North House; however, the research and argument were newly produced for the fulfillment of this thesis.

Part 2: Environmental Responsiveness and Energy Efficient Systems – The Design and Integration of the Distributed Responsive System of Skins (DReSS) presents the design and operation of the dynamic shading system as a hybrid active/passive envelope assembly. This section discusses the major design developments that led to the final implementation of the DReSS as well as the interdependencies between each functional component and the resulting energy performance. A detailed description of the control strategy is provided as well as an overview of the mechanical system, photovoltaic system, and opaque building assemblies. Lastly, this section explores the implications of this reconfigurable envelope assembly on fundamental architectural relationships that are typically articulated through the building envelope: privacy and spectacle; boundary and connection between interior and exterior; and manipulation of light and view.

Much of the description of the technical systems, components, and energy modeling results in this section, were adapted from text originally written for the “North House Engineering Design Narrative”. The Engineering Design Narrative was produced as a contract deliverable and competition requirement for the US DOE 2009 Solar Decathlon Competition. This text was written by graduate students on the North House UW engineering team, namely Sebastien Brideau, Brent Crowhurst, Ivan Lee, Bartosz Lomanowski, and Andrew Marston. All diagrams accompanying this text were produced by the author for inclusion in this thesis.

Part 3: Inhabitant Responsiveness and Sustainable Lifestyles – The Design and Integration of the Adaptive Living Interface System (ALIS) and the Central Home Automation System (CHAS) describes the design principles, components, and operations of these two systems. This section also contains material adapted from the Engineering Design Narrative, which was originally written by Brent Crowhurst, as well as SFU graduate students, Kevin Muise and Johnny Rodgers.

Finally, the *Conclusion* speculates on the implications of applying similar responsive systems to domestic environments on a broad scale, opening questions regarding our cultural relationship to technology, and examining how different philosophies of making might lead to different outcomes.

“We shape our buildings; thereafter they shape us”

- Winston Churchill

“We become what we behold. We shape our tools and then our tools shape us.”

- Marshall McLuhan

It is not clear who makes and who is made in the relation between human and machine. It is not clear what is mind and what body in machines that resolve into coding practices. In so far as we know ourselves in both formal discourse (for example, biology) and in daily practice [...], we find ourselves to be cyborgs, hybrids, mosaics, chimeras. Biological organisms have become biotic systems, communications devices like others. There is no fundamental, ontological separation in our formal knowledge of machine and organism, of technical and organic.

- Donna Haraway

PART I

INTERACTIVE ARCHITECTURE AS A STRATEGY FOR PROMOTING SUSTAINABLE INHABITATION

Energy consumption in buildings is a socio-technical problem that demands solutions which consider the interaction between technology and its users. The field of Interactive Architecture considers the building and its interaction with the inhabitants as an integrated system, offering a promising model for synthesizing these social and technical considerations. The North House extends this idea to include the interactions between the building, the inhabitants, and the exterior environment. It employs mechanisms of feedback between these elements to conserve energy in operating the building while enabling the inhabitant to live an energy conscious lifestyle. This essay positions the North House with respect to the field of Interactive Architecture. It discusses the particular types of feedback present in the North House, and how they contribute directly or indirectly to energy conservation in the home while also creating a healthy and stimulating environment for the inhabitant.

Introduction

The building sector is the single largest contributor to energy consumption and green-house gas emissions in the United States. Architecture 2030, a non-profit independent organization of design and construction professionals, identified that the building sector is responsible for 48% of annual energy consumption and GHG emissions in the US, and furthermore, that 76% of total power plant generated electricity is used to operate buildings. These figures, combined with the projection that 75% of the US building stock will either be new or recently renovated by the year 2035, points to a “historic opportunity” for the building industry to positively impact the onset of climate change.¹ Architects, city planners, and environmentalists the world over have embraced statistics such as these as a call to action, and the foundational justification for the green building movement. Though designing and constructing more energy efficient buildings and technologies is absolutely critical, this alone will be insufficient to address the full scope of the problem.

Energy consumption is not merely a technical problem; it has social, political, and personal dimensions that are equally critical to the formulation of

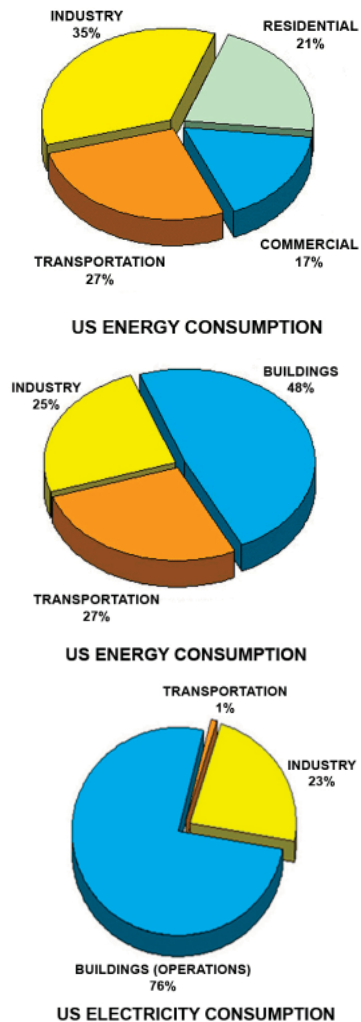

Figure 1.1;
 Architecture 2030 graphs illustrating data from the US Energy Information Administration.
 (top) Total US energy consumption as categorized by the USEIA.
 (middle) Total US energy consumption resorted by Architecture 2030 to consolidate energy used by buildings.
 (bottom) Total US power plant generated electricity consumption, resorted by Architecture 2030 to consolidate electricity used by buildings.

a comprehensive solution.^{2 3} Social scientists have long recognized that motivations to consume or conserve energy are a societal issue, prompting the argument that deep social change is necessary to achieve real and lasting energy reduction in buildings.⁴ This argument is supported by research which shows that differing patterns of inhabitant behaviour can produce variations greater than 300% in home energy use - even when accounting for differences in housing type, equipment, and family size.⁵ A recent study which monitored energy use patterns in a community of Zero Energy Houses in California, showed that while the technological features of the building were effective at reducing net energy footprint, the inhabitant's energy consumption patterns remained identical to those of their neighbours in non-Zero Energy Houses.⁶ This suggests that despite a conscious choice to live in high-performance sustainable buildings, inhabitants tend not to change their consumption habits in any significant way. Designers must therefore include as a fundamental part of their mandate user involvement and public education on sustainable building literacy.

This position is echoed by the US Green Building Council's National Green Building Research Agenda (2007), which calls for "transformative change" in technology and practice across the design and construction industry, in order to achieve major improvements to social and ecological sustainability.⁷ The research agenda identifies a massive opportunity for research and development to improve green building technologies and outlines the potential for large-scale market uptake to effect substantial improvements in the North American building stock as a whole. The research agenda identifies priority research topics focused mainly on improving building technologies. However, in each case it also calls for improvements to the way people interact with these technologies throughout construction, commissioning, and long-term operation.

If architects are to take up the challenge set out by Architecture 2030 and the USGBC National Research Agenda, we must first acknowledge energy consumption as a socio-technical problem. It is therefore critical to consider the relationship between inhabitant and building technology in order to properly address the urgent environmental imperative to reduce building energy consumption.

Interactive architecture offers a promising conceptual framework for synthesizing the social and technical aspects of energy consumption in

buildings. This field considers both user and technology, or inhabitant and building, as equal parts of one system that interact with each other through feedback mechanisms.

The North House is designed within this paradigm, employing two strategies that incorporate feedback to and from the occupant to dramatically reduce energy consumption in the home. Furthermore, the North House extends the scope of this interactive paradigm to include interaction with the exterior environment. The DReSS reduces heating and cooling loads by automatically managing passive solar gain and daylighting in response to exterior climate conditions and inhabitant inputs. The ALIS assists the inhabitants in reducing their personal energy consumption by providing them with easy control of the building settings along with meaningful quantitative and qualitative feedback on the impacts of their decisions.

These systems have the added advantage of confronting energy consumption in the home, where there exists the opportunity to reach a broad population and develop an intimate connection to the identities, values, and daily practices of the inhabitant. Together, the North House's two responsive strategies can dramatically reduce energy consumption in the home while also creating a healthy, stimulating domestic environment that fosters energy awareness in the inhabitants and a greater connection to the outdoors.

Interactive Architecture

The birth of interactive architecture coincided with a period of disillusionment in modern architecture which was leading young architects to search for new design processes and new ways of meeting users' needs. In the 1960s, visionary theorist Gordon Pask began exploring the emerging field of cybernetic theory in relation to architecture. This gave birth to a generation of forward thinking projects that ranged from the wildly visionary work of Archigram to the pragmatic optimism of figures like Charles Eastman. In spite of significant changes in culture and technology in the past five decades, Pask's work remains strikingly relevant to the cutting edge of architecture today.

Pask envisioned a 'mutualist' rather than 'functionalist' architecture as a two part system composed of physical and social structures. He argued that architecture is an implicitly dynamic system in which seemingly static physical structures regulate fluid social structures in a dynamic exchange. He proposed

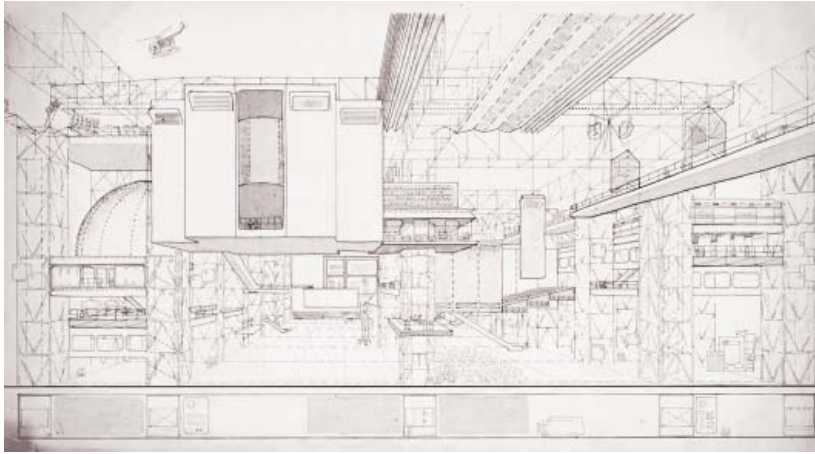

Figure 1.2: Interior Perspective of Cedric Price's Fun Palace, (1961) commissioned by Joan Littlewood, a renowned theatre director and producer. The project consisted of a fixed grid of structural steel lattice columns and beams. All programmatic elements were moveable or quickly demountable, these included hanging theatres, activity spaces, cinema screens, and speakers. Though the project was never realized it is recognized as price's most celebrated work.

that architects should enhance this dynamic system by designing buildings that engage in a 'conversation' with their inhabitants. In this 'conversation', both parties (user + system, or inhabitant + building) learn from and direct the other, configuring and reconfiguring the environment in un-predetermined ways. This vision of interaction relies on 'under specified goals' enabling the user and the system to shape an unlimited set of outcomes. Rather than a designer predetermining appropriate responses to user input, the system measures the reaction to its output and continues to modify its actions according to this response.⁸

Pask's ideas spawned a field of theory and design that has come to be known as 'interactive architecture' or 'responsive architecture'. The ideas and projects that originated within this field, and the growing body of contemporary work that has followed, varies greatly and resists a simple definition. However, a defining characteristic of interactive and responsive architecture, and one that is central to the development of the North House, is the use of information exchange, or feedback mechanisms, between user and system to enhance building performance in a variety of ways.

One of the first architects to seriously explore the implications of responsiveness in buildings was British architect and theorist Cedric Price. Price worked directly with Pask in conceiving of 'anticipatory architecture', or architecture designed for continual change in order to offer new possibilities to society as a whole. Most famously, his unbuilt project The Fun Palace (1960-61) consisted of an open structural framework populated by gantry cranes that reconfigured programmatic elements such as walls, platforms, and stairs, according to the desires of its many users.⁹ In 1969, American architect and author Andrew Rabeneck applied similar ideas of user-centered reconfigurability to the much more pragmatic goals of combating building obsolescence. He projected a future model of design and construction in which building components are manufactured quickly and cheaply by computer controlled machines and are therefore economical to repair, replace, or reconfigure¹⁰ – presciently describing current methods of mass customization in computers and automobiles. Concurrently, Canadian born psychiatrist Warren Brodey proposed a radical approach to human-machine interaction in which "men evolve intelligent machines, and intelligent machines evolve men"¹¹. Later Brodey would apply these ideas to the built environment, envisioning a new generation of buildings that exhibited self-organizing, evolving intelligence.¹² Inspired by this line of thinking, American architect

and computer scientist Nicholas Negroponte proposed architecture (or machines) that could learn problem solving skills.¹³ He later proposed to equip architecture with sophisticated analytic capabilities, whereby the building would have an adjustable cognitive model of both the inhabitant and itself, on which to map their interactions, and thus 'learn' about its inhabitant.¹⁴ Ranulph Glanville, a former student of Pask's, added a further dimension to the on-going discussions concerning 'interaction' and 'intelligence', by continuing to ground contemporary theories in human experience. In a recent essay, Glanville reexamined the notion of 'intelligence', defining it as a quality that exists insofar as it is recognized between one party and another. A person, building, or computer is intelligent when it can interact with another intelligent being and can make unexpected contributions to the conversation, such that each party can recognize intelligence in the other.¹⁵

While these thinkers explored complex ideas of 'intelligent architecture', a parallel stream of investigation was developing which subverted the very notion of 'architecture as building'. Theoretical projects such as Reyner Banham's Un-house in 1965,¹⁶ and Michael Webb's Suitaloon in 1966,¹⁷ proposed to strip away all permanent and restrictive structural elements that traditionally constitute a building. Their work sought to fulfill requirements for human comfort and inhabitation through highly responsive, fully conditioned and serviced, mobile dwelling units akin to tents or expanded clothing.

In spite of the vigorous intellectual investment in these ideas, barriers to technological and economic feasibility prevented them from broader uptake within the design community. In the 1990s, the surge of innovation in computational devices and communication infrastructure brought about renewed interest in 'intelligent environments' (i.e. spaces embedded with computation and communication technology).¹⁸ Since then, many 'smart homes' and 'smart workplace' projects have made use of new communication protocols, wireless networks, embedded sensors, actuators, data-loggers, and multi-media devices as well as advanced modelling software. These projects have goals as varied as monitoring occupant health and security, supporting workplace productivity, managing interior climatic conditions, and developing anthropomorphic relationships between the inhabitant and their sensing environment.^{19 20}

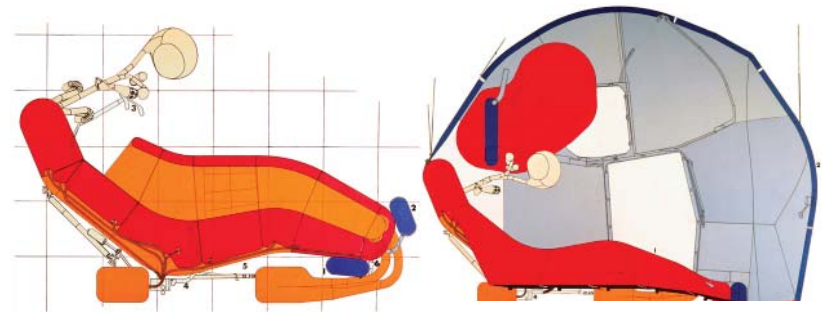

Figure 1.3: Michael Webb's 'Suitaloon' project, a completely serviced and self-sufficient wearable dwelling unit.



Figure 1.4: In *Open Columns*, Omar Khan creates a sculpture that manages the build-up of carbon dioxide in its environment. Ceiling mounted sensors register the accumulation of CO₂ and, at a certain threshold, the piece acts to reduce this CO₂ build-up by lowering a column made of elastomeric material. This column becomes effective, not by acting on the air around it, but by causing on the group of people who had been gathered, emitting CO₂ beneath it, to move away. The work acts on the viewers' sense of personal and social space, causing them to take a particular action without prescribing to them what that action should be.



Figure 1.5: Gorbet Design's work *P2P: Power to the People*, first installed at Kitchener City Hall, maps a screen of electric light bulbs, hung on the front facade of the building, to a field of standard residential light switches located within easy reach of the public, and with a direct line of sight to the lights. The public can operate the switches to create words or images on the screen. This work was particularly successful at engaging a broad cross section of the public, and stimulated discussion concerning civic responsibility, censorship, and empowerment.

The developments in Interactive Architecture are part of a much larger cultural preoccupation with our increasingly interdependent relationship with technology. The same technological innovations that enable experimentation with 'smart houses' and 'smart workplaces' are radically transforming the way we communicate with each other, the way we locate ourselves in the world, the way we do business, the way we govern our nations, and the way we care for our young, our sick and our aged. Though we recognize these transformations, questions are emerging in regards to the social and political implications of the ubiquitous presence of these new technologies. Can responsive technologies influence the behaviour of its users? Should they? Responsive technologies mediate our relationship to the natural and built environment - how do we evaluate to what degree this results in an engagement or disengagement with our surroundings? Can responsive technologies empower their users to engage with their social, political, or ecological surroundings in new ways? The North House takes the position that we can and we must take care to craft our relationship with these technologies according to our values, lest we allow technologies to unconsciously posit values for us.

The North House is part of a new generation that is applying the concepts of interactive architecture to the goals of sustainable living, and reduced resource consumption in the home. It builds on Pask's vision of an architecture that develops a 'conversation' with its inhabitants, but it is critical of the two-part system, which considers only the interaction between the container and the contained. Contemporary discourse forces us to recognize that one cannot meaningfully understand any object (or organism) without also understanding the complex system of transactions that occur between that object and its surroundings. Acknowledging this, the North House engages in a three-part system that extends the 'conversation' between building and inhabitant outward to include the exterior environment. This three-part conversation is not rigidly delineated, but rather it is the opening of a nuanced exchange that invites the inhabitant to discover their relationship to the building and its surroundings.

While the North House seeks a meaningful engagement with technology, it does not fetishize it – a tendency, it could be argued, that is exhibited by some of the above examples which arose in a period of extreme technophilic optimism. It does not pursue the agenda of creating a building with artificial intelligence. Nor does it use responsiveness to mimic an anthropomorphic

relationship between building and inhabitant. Responsive technologies are not considered ends in themselves; rather, the North House makes use of responsive strategies only in as far as they serve the purposes of 1) creating a healthy domestic environment and 2) conserving energy and enabling the inhabitant to live sustainably. Rather than a computationally sophisticated proposal for a building that actually 'learns' about its inhabitant, the North House 'learns' to perform more efficiently precisely because the inhabitant, who is part of the system, learns to operate it more intelligently.

The Power of the House

The North House DReSS and ALIS are intended for use in the domestic environment. While their application is not limited to the residential sector, the house is perhaps the most valuable building type with which to confront in the problem of energy consumption in buildings. The residential sector is the fastest growing construction sector. Over 211,000 new housing starts were recorded in Canada in 2008, compared to approximately 137,000 ten years prior. This sector contributes almost half of total building energy consumption.²¹ In spite of the much reviled environmental performance of the North American house, particularly the single family dwelling, this model is becoming the ideal which is sought after by much of the developing world. Given the magnitude of the rise of the middle class in the developing world, coupled with alarming projections of global population growth, it is all the more critical that we specifically address energy consumption in the residential sector and develop viable alternatives with lower energy footprints.

More immediately, this sector affects the entire population in a profoundly personal way. The identification between self and home has been explored by psychologists, theorists, poets, and architects. The home is our first and often our last contact with architecture. It represents safety, seclusion, and intimacy; and it is the setting for our closest relationships. It is our territory; it protects us and our possessions. The home is the structure that sustains our survival, while also serving as a physical manifestation of our relationship to the outside world. The North House attempts to leverage this profound connection between the house and the inhabitants' personal identities, values and behaviours by equipping the inhabitant with tools that foster environmental consciousness as a value, and support habits of energy conservation. It is hoped that values and habits developed in the home will be carried to the workplace and into the public sphere.

Environmental Responsiveness and Energy Conservation

Using environmental feedback to enhance passive conditioning in buildings makes passive strategies more effective, and more viable for a broader range of people. Though passive solar building principles have long been understood and promoted as a strategy for energy conservation, the responsibility for the occupant to actively operate the house has been a barrier to widespread adoption of passive conditioning strategies. Automatically managed passive systems, such as North House's DReSS, respond to environmental conditions to optimize passive thermal performance and daylighting throughout the range of conditions common to the Canadian climate, thus significantly reducing operational energy consumption throughout the year, without requiring constant attention from the inhabitants.

In a study of 35 American families living in "green" houses, who demonstrating substantial commitment to sustainable living, Woodruff et. al. found that participants managed their houses and energy footprint by "constantly reconfiguring windows, doors, skylights, solar panels, etc." One participant articulated the relationship: "Now, passive solar is somewhat of a misnomer. It's passive from the point of view of the building [...] because the occupants have to be constantly active." This was a celebrated way of life for the participants, who expressed pride in their commitment and ongoing achievements, as well as their relative uniqueness, and special social status in their communities; but this necessarily intensive commitment is a significant deterrent for the average family in adopting these otherwise advantageous passive conditioning strategies.²² This is especially true since improper operation can result in spaces that are neither comfortable nor energy efficient.

I will emphasize a distinction between 'operable' and 'responsive'. Operability is a simple one way interaction; the inhabitant opens a window and receives fresh air, or opens shades and floods the room with sunlight. This operation may affect the interior temperature, which rises above, or drops below the specified set-point, triggering the mechanical system to deliver heat or cool until the temperature reaches the set-point. In a responsive system, such as the North House DReSS and ALIS, an inhabitant's action does not simply trigger a reaction from the building system, but both action and reaction can be adjusted based on real-time exchange of information. Thus, the inhabitant may open the window to receive fresh air, or open the blinds to flood the room with sunlight - but if these actions impact the optimized energy performance of the building, they will be notified, and may choose to either

to adjust their own actions or proceed with their action knowing the building system will adjust itself accordingly.

During the Solar Decathlon competition the North House performed very well, maintaining a consistent top three position in both Comfort Zone (maintaining a consistent indoor temperature and relative humidity) and Net Metering (surplus energy generation relative to normal use of the home). Though it has yet to be tested over the course of an entire year, building energy simulations predict that the DReSS can effectively eliminate cooling loads and reduce heating loads to 45% of the loads predicted for a building of similar size, orientation, and massing, but with 25% glazing and without the DReSS assembly. Total annual energy consumption, including energy expended for heating, cooling, hot water, appliances, and lighting, is estimated at 4,400 kWh/y, which is more than offset by the 10,450 kWh/y of produced by the PV arrays.

Environmental Responsiveness and Inhabitant Well-Being

An environmentally responsive building envelope such as the DReSS offers several advantages beyond energy conservation. By transforming windows from energy cost to energy resource, we have found the freedom to give inhabitants complete control over daylight, views, and privacy - while the automated adjustments of the exterior shades serve as a constant expression of the interdependent relationship between the inhabitant, their home, and the exterior environment.

The importance of daylight and natural views on human physical and psychological health has been supported by increasingly diverse research. Frumkin presents an overview of studies comparing similar populations with and without views that include some degree of natural environment. In these studies, the presence of these views is linked to patients recovering from surgery who experience reduced pain and shorter hospital stays; residents of public housing estates who exhibit higher levels of self-confidence and self-discipline, and a reduction in violence and crime rates; and prison inmates who make fewer sick calls.²³

Loftness and Snyder present similar results among studies comparing populations in 'sunny' and 'dull' rooms. In these studies, access to sun, particularly sunlight variations throughout the day, is linked to decreased recovery times for patients with psychological disorders such as Seasonal

Affective Disorder and Bipolar Disorder; as well as patients recovering from surgery. Simulated daylight variation has also been linked to improvements in short term-memory and reasoning tasks in night shift workers.²⁴ In a northern climate where daylight hours are significantly reduced in winter, these health and psychological benefits are all the more critical.

The North House DReSS does more than provide access to daylight and views; it also acts as a pedagogical tool, where the dynamic adjustments of the exterior shades act as ambient cues that inform the inhabitant of the changing relationship between interior and exterior. Architectural educator David Orr argues that buildings implicitly teach their inhabitants how to think about the connections between building and site, interior and exterior, the origins of materials, and the value of resources such as energy. He posits that most buildings teach us that energy is cheap, “disconnectedness is normal,” and that the process involved in producing and disposing of materials is consequence free.²⁵ To a certain extent the North House’s technological systems have been aesthetically suppressed, which at first glance may seem to run counter to these didactic ambitions. However, rather than explicating the technological devices, North House prioritizes exposing the energy flows between the inhabitant, the house, and the environment, including daylight, solar heat, natural ventilation, as well as food production and sensual delight provided by the view and inhabitation of the landscape.

Inhabitant Responsiveness and Energy Conservation

Much of the operational energy in a typical building is dedicated to the provision of comfort – conditioning, lighting, and otherwise operating the building. While this energy load can be reduced by efficient equipment and building envelope systems, further energy conservation can be achieved by involving the inhabitant directly in the control of their interior environment.

Prevailing attitudes and design standards regarding comfort provisioning were shaped by Fanger’s human heat balance model, developed in 1970, which quantitatively describes an ideal “comfort zone” based on laboratory testing on human subjects removed from all contextualizing factors.²⁶ Along with the increasing dependence on mechanical conditioning of buildings throughout the 20th century, control of the provision of thermal comfort shifted from occupants to equipment.²⁷ Now, conventional design practice relies fully on mechanical conditioning to fulfill this narrow definition of thermal comfort, applying it universally regardless of differences in climate, resource use,

cultural norms, and personal preference - with the consequence of globally standardizing comfort expectations while simultaneously erasing traditional cultural adaptations to climate conditions.²⁸

However, Brager and de Dear argue that comfort is subjective, rather than absolute, and is shaped by both cultural expectations and individual experience of a space. They present a field study comparing occupant comfort in mechanically conditioned and naturally ventilated office buildings which found that occupants in mechanically conditioned buildings became adapted to the “narrow, constant conditions typically provided by the mechanical system, and became uncomfortable quickly if conditions deviated from those narrow set-points” regardless of exterior temperature. In contrast, occupants of the naturally ventilated buildings actually preferred temperatures that reflected the cycles of the exterior conditions. They argue for an adaptive approach to comfort provisioning, which is culturally and climatically specific and which sees thermal fluctuation as acceptable and even pleasurable stimulus – pointing to psychological and cognitive studies which have found that subtle variation in environmental conditions provides stimuli that are essential to our well-being.^{29 30 31}

Regardless of whether the interior environment is conditioned passively or mechanically, human comfort, well-being, and productivity are also linked to the amount of real or perceived control that the user has over their environment. Furthermore, having more control over their environment increases inhabitants’ tolerance for ‘less-than-ideal’ conditions.³² Based on this information, Cole and Brown propose adding the idea of ‘inhabitant intelligence’ to existing concepts of building intelligence “wherein the building explicitly enables its users to make appropriate adjustments in the environmental conditions” as a means of balancing comfort provision with energy conservation. However, this concept relies on the assumptions that users understand the available control options, and also that they will make appropriate and intelligent choices.³³ This underlines the importance of a well-designed interface to legibly present control options to the user, and to provide the necessary information to support them in making informed decisions. Bordass and Leaman stress the importance of control interfaces that are designed to match the knowledge and needs of the occupants, observing that inappropriately designed interfaces can undermine the performance of otherwise sophisticated and well-designed building systems.³⁴



Figure 1.6: This scene from the movie Brazil humorously illustrates the common relationship between occupants and mechanical systems. These systems are understood to be necessary, but are far removed from the occupants realm of understanding or control.

The Adaptive Living Interface System (ALIS) allows users to control all aspects of the interior environment including lights, temperature, humidity, ventilation, as well as privacy, daylight and glare through the interior blinds and exterior shades. Devices can be controlled with a fine degree of resolution either individually, in groups, or as user-defined preset “modes” encompassing settings for all devices. The touchscreen control interfaces are distributed to convenient locations throughout the home, and can also be accessed through a smartphone.

Provision of Feedback and Energy Conservation

Beyond the simple act of giving control to inhabitants, providing immediate feedback on their actions and aggregated feedback on their lifestyle patterns can assist them in making intelligent and informed decisions with respect to energy and water consumption, as well as making long-term changes in their lifestyles.

The suite of technologies that constitute ALIS includes an extensive monitoring and data-logging system, three different types of feedback mechanisms, and a social network connecting the (theoretical) community of ALIS users. The monitoring system collects data on energy consumption by use, water consumption, production of solar power and solar hot water, as well as interior and exterior environmental conditions. This information is accessible to the inhabitant via a web application that allows them to view data in many different combinations and at different timescales. They can view their historical patterns of consumption day-to-day, week-to-week, or year-to-year, and they can view a breakdown of energy consumption patterns by use, and compare these to weather patterns or interior configuration. The community of ALIS users can choose to share their statistics with each other, providing meaningful comparison, and they can share knowledge for improving personal performance.

A recent study by the National Environmental Education and Training Foundation found that while a majority of Americans considered themselves to be knowledgeable about energy issues, only 12% of them could pass a basic energy quiz.³⁵ Average American families use neither scientific units (Joules or Btus) nor commercial units (kWh or Ccfs) in thinking about energy consumption, rather, they use “folk units” which are familiar, multi-purpose, and easily visualized, such as dollars, gallons, and months. Furthermore, in the absence of meaningful ways of measuring relative energy load of specific

devices, they attribute a value based on observable but often irrelevant criteria such as the quantity of human labour it replaces or the frequency with which they interact with a device, leading to misguided concepts about the relationship between their activities and their consumption³⁶. For example, when asked what their family could do to reduce energy consumption, many people suggested reducing lighting first, while few recognized reducing hot water as an option, when in fact hot water production accounts for a much greater proportion of a typical families overall energy consumption.³⁷ 'Like shopping at a grocery store with no price-tags' is a common simile used to illustrate the consumers attempts to understand their energy consumption in the absence of detailed feedback. To the consumer, receiving a monthly energy bill is like receiving an aggregate grocery bill after making a months-worth of purchases – from which they must construct a mental model for understanding their costs.³⁸

Despite this, there is a clear desire for learning about energy conservation. The vast majority of the American public supports the idea that energy conservation should be taught in schools, and expresses a desire to reduce personal energy consumption.³⁹ Many studies that examine the use of energy monitors in homes have found that consumers welcome the information and express enthusiasm for installing permanent energy monitors in their homes.⁴⁰ In Woodruff's study, participants enthusiastically consumed performance feedback and treated it as a competitive game in which they could constantly improve performance through new and creative strategies. However, Woodruff also noted that once the participant learned to recognize patterns in the performance of their technologies, they often lost interest in the simple monitoring systems; many expressed a desire for more advanced data collection and analysis tools that could advance their understanding more thoroughly.⁴¹

The European Union's Energy End-Use Efficiency and Energy Services Directive (2005) emphasizes feedback strategies such as informative billing, and electronic metering as a means of achieving overall demand reduction. Darby presents a thorough review of research on the effectiveness of feedback on residential energy consumption. She notes that in general, the effectiveness of feedback is highly dependant on a) general context, the cultural attitudes and motivations of the population, as well as the characteristics of the technologies involved, b) quality of feedback, the legibility and frequency of delivery, and c) synergies with other factors or strategies, such as goal setting or receiving advice.

Different types of feedback mechanisms can produce different results. Basic metering can be an effective form of feedback for motivated participants, such as those who enrol themselves in conservation programs, where frequent self-reported meter readings coupled with meaningful advice assist them in achieving 10% energy savings through behavioural change alone. Direct displays are portable devices located within the home, which typically show instantaneous electrical consumption and in some cases a cost-per-hour at the current use rate, several studies have shown these devices to help achieve savings in the order of 10%. One of the more effective forms of feedback among the studies presented by Darby was an interactive on-line display showing historic, daily, and ten-day consumption patterns, as well as living room temperatures and a comparison to other homes. This trial, undertaken in Japan, resulted in 18% reduction in electricity use and 9% reduction in gas use compared to a control group. A similar study found an 8.5% reduction in Dutch households using an interactive web-page.⁴² Ambient displays have also shown success at encouraging particular energy conscious behaviours, such as a flashing light that tells users when outdoor air temperatures are low enough to cool the home naturally by opening a window.⁴³

Contextualizing the feedback data is also an important aspect of its success. Participants tend to respond well to historical comparisons in which their own consumption patterns are presented in the long-term so that they can understand consumption fluctuations based on time of year or major changes in their lifestyle. Some studies have found participants to be distrustful of feedback that compares them to “similar users” or a benchmarked target, as they may doubt the validity of their comparison group or predetermined target. Siero, however, found that providing comparative feedback to peers with shared energy saving goals increased energy savings in spite of remarkably little change in effort or attitude.⁴⁴ This points to the need for comparative data that is real and meaningful to consumers, rather than an abstract or normative model.

Few studies have looked at the effectiveness of delivering disaggregated information (i.e. a detailed breakdown of energy consumed by use or device) to the consumer, partly because of the technical difficulty and expense of delivering this information. However, consumers do tend to welcome information on the relative energy consumption of various end-uses.⁴⁵

Various other factors can have synergistic effects with feedback. For example, several consumer energy studies confirm that feedback is markedly more effective when combined with goal setting.^{46 47} Investment in energy generation technologies also seems to amplify the effectiveness of feedback. In households who invested in energy production technologies, such as PV or solar thermal collectors, and where feedback on both energy production and consumption was visible, conservational behavioural changes reduced total energy consumption by as much as 20% from consumption levels prior to installation of the system.

Lastly, in order for feedback mechanisms to generate persistent behavioural changes, it is important that they remain in place in the home. Though some researchers argue that behavioural changes developed over 3 months tend to persist for at least a year, shorter term tests with feedback mechanism showed that consumption patterns revert to normal once they are removed.⁴⁸

Incorporating Social Feedback

The ALIS web application and social networking site is a flexible platform for expanding the resources of the home out to the community where collaboration or friendly competition can motivate further integration of sustainable choices into domestic life.

Journalist Bill McKibben argues that the proliferation of communication technologies is transforming environmental activism from the realm of politicians and large organizations to a movement that is accessible to anyone who has access to the internet: “the fight against global warming requires all kinds of technology - solar panels and windmills, but also servers and routers”⁴⁹ Participatory web-based media such as blogs, online forums, and mailing lists are becoming popular means for people to craft a “personalized environmentalism”.

The recent proliferation and widespread use of social networking sites, demonstrate not only the potential reach of this media, but also its flexibility to support infinitely varied user-created applications. It provides an infrastructure for events, social causes, professional development, products, or any other shared interest. Using social networks as a further feedback mechanism (i.e. feedback from peers) to support an individual in living sustainably can add a powerful social incentive and can also enhance the knowledge and resources of the whole community. Mankoff et. al. argue that social networking is an

appropriate media for motivating reduction to personal energy consumption.⁵⁰ She points to social movement theory, which identifies that the mobilization of political movements has historically occurred through “informal networks, pre-existing institutional structures, and formal organizations”⁵¹ and furthermore, that “networks have 3 important functions: “structurally connecting prospective participants to an opportunity to participate, socializing them to a protest issue, and shaping their decision to become involved.”^{52 53} Passy and Giugni point out that sustained participation in a political movement is directly related to the degree to which it is “integrated with other life goals and activities of the participants” and therefore involving particular goals into existing personal relationships can help individuals to stay engaged with these goals.

Online social networks can further enhance the inhabitant’s efforts toward energy conservation by leveraging the power of group behaviour. Siero et al. found that the addition of feedback about a different group’s performance increased conservation behaviour, even with no stated competitive agenda. He also noted that “simply being part of a group can improve [individual] performance”⁵⁴ Woodruff’s study of green households, described above, corroborates these ideas. Study participants described being motivated by friendly “competitive conservation” against other households with similar systems.⁵⁵ Based on this study, Woodruff suggests other design strategies for encouraging energy conservation including depth-based learning, mentoring, identity expression, modest mental challenges, and organized social protest communities;⁵⁶ strategies which could readily be implemented in an online social network.

Conclusion:

In the face of looming climate change and energy scarcity, the building sector urgently needs to find solutions for dramatically reducing its energy consumption. Technological solutions alone will be insufficient to achieve the scale of change that is required. Adequate solutions must advance energy efficiency of buildings and technologies but also engage the personal, social, and political motivations of those who inhabit the buildings and use the technologies.

The North House is part of a new generation of architectural projects that seeks this kind of multi-dimensional solution. It looks to ideas developed in the field of Interactive Architecture to find an appropriate conceptual framework for unifying these aspects. And while the project finds much common ground with this line of thinking, it expands on the discourse by addressing not only the dynamic interaction between building and inhabitant, but also the complex relationship between these elements and their surroundings. The North House includes this third dimension to enhance the energy performance of the building and the well-being of its inhabitants. It uses two responsive strategies, the DReSS and the ALIS, harnessing this three way interaction to produce a building that uses extremely little energy while creating a healthy and stimulating domestic environment that supports the inhabitant in living a low energy lifestyle. If applied on a large scale, responsive strategies such as these could generate significant energy savings across the residential sector, as well as foster energy conscious behaviour and attitudes in the broader population.

- 1 “The Building Sector: A Hidden Culprit,” in Architecture 2030 [database online]. [cited 2010]. Available from http://www.architecture2030.org/current_situation/building_sector.html.
- 2 Kathryn B. Janda, “Buildings Don’t Use Energy: People Do,” in *Architecture, Energy and the Occupant’s Perspective - Proceedings of the 26th conference on Passive and Low Energy in Architecture (PLEA)*, eds. Claude Demers and Andre Potvin. Anonymous (Quebec, Canada: Les Presses de l’Universite Laval, 2009), 22-27.
- 3 Paul C. Stern and Elliot Aronson eds., *Energy Use: The Human Dimension*, Anonymous (New York: W.H. Freeman and Company, 1984)
- 4 Janda, *Buildings Don’t Use Energy: People Do*, 22-27.
- 5 Robert Socolow, *Saving Energy in the Home : Princeton’s Experiments At Twin Rivers*, (Cambridge, Mass: Ballinger, 1978)
- 6 M. Kesee, *Setting A New Standard - The Zero Energy Home Experience In California*, Anonymous , Orlando, Florida ed. International Solar Energy Society, 2005)
- 7 USGBC Research Committee, *A National Green Building Research Agenda*, ed. Martha Bohm, Anonymous US Green Building Council, Nov 2007, Revised Feb 2008), pp7-8.
- 8 Gordon Pask, “The Architectural Relevance of Cybernetics,” *Architectural Design* September (1969): 494-496.
- 9 Cedric Price. -, (London: Architectural Association, 1984)
- 10 Andrew Rabeneck, “Cybermation: A Useful Dream,” *Architectural Design* September (1969): 497-500.
- 11 W. Brodey and N. Lindgren, “Human Enhancement through Evolutionary Technology,” (1967)
- 12 Warren Brodey, “The Design of Intelligent Environments: Soft Architecture,” *Landscape Autumn* (1967): 8-12.
- 13 Nicholas Negroponte, “Toward a Theory of Architecture Machines,” *Journal of Architectural Education (1947-1974)* 23, no. 2 (1969): 9-12.
- 14 Nicholas Negroponte, *Soft Architecture Machines*, (Cambridge, Mass: the MIT Press, 1975), 239
- 15 R. Glanville, “An intelligent architecture,” *Convergence* 7, no. 2 (2001): 12-25.
- 16 Reyner Banham, “A Home is not a House,” in *Meaning in architecture*, eds. Charles Jencks, George Baird and William Dendy. Anonymous (London: Barrie & Rockliff, The Cresset Press, 1969), 109-118.
- 17 Tristan d’Estree Sterk, “Responsive Architecture: User-centered Interactions within the Hybridized Model of Control,” 2010, April 29 (2010)
- 18 Michael Fox and Miles Kemp, *Interactive architecture*, 1st eded. (New York: Princeton Architectural Press, 2009)
- 19 ibid.
- 20 Diane J. Cook and Sajal K. Das, “How smart are our environments? An updated look at the state of the art,” *Pervasive and Mobile Computing* 3, no. 2 (2007): 53-73.
- 21 *The Building Sector: A Hidden Culprit*,
- 22 Allison Woodruff, Jay Hasbrouck, and Sally Augustin, *A Bright Green Perspective on Sustainable Choices*, Anonymous , Florence, Italyed. CHI, 2008), 313-322.
- 23 Howard Frumkin, “Nature Contact and Human Health: Building the Evidence Base,” in *Biophilic design : the theory, science, and practice of bringing buildings to life*, eds. Stephen R. Kellert, Judith Heerwagen and Martin Mador. Anonymous (Hoboken, N.J.: Wiley, 2008), 107-118.
- 24 Vivian Loftness and Megan Snyder, “Where Windows Become Doors,” in *Biophilic design : the theory, science, and practice of bringing buildings to life*, eds. Stephen R. Kellert, Judith Heerwagen and Martin Mador. Anonymous (Hoboken, N.J.: Wiley, 2008), 119-132.
- 25 David W. Orr, “Architecture as Pedagogy II,” *Conservation Biology* 11, no. 3 (1997): 597-600.
- 26 P. O. Fanger, *Thermal Comfort; Analysis and Applications in Environmental Engineering*, (Copenhagen: Danish Technical Press, 1970)
- 27 Raymond J. Cole and Zosia Brown, “Reconciling human and automated intelligence in the provision of occupant comfort,” *Intelligent Buildings International*, no. 1 (2009): 39-55.
- 28 Raymond J. Cole, “Green Buildings - Reconciling Technological Change and Occupant Expectations,” in *Buildings, Culture and Environment : informing local and global practices*, eds. Raymond Cole and Richard Lorch. Anonymous (Oxford, UK ; Malden, MA: Blackwell Pub., 2003), 57-82.
- 29 D. A. McIntyre, *Indoor Climate*, (London: Applied Science Publishers Ltd., 1980)
- 30 W. Heron, “The pathology of boredom,” *Scientific American* 196, no. 1 (1957): 52-57.
- 31 K. Gerlach, “Environmental design to counter occupational boredom,” *Journal of Architectural Research* 3, no. 3 (1974): 15-19.

- 32 Raymond J. Cole and Zosia Brown, "Human and Automated Intelligence in Comfort Provisioning," in *Architecture, Energy and the Occupant's Perspective - Proceedings of the 26th conference on Passive and Low Energy in Architecture (PLEA)*, eds. Claude Demers and Andre Potvin. Anonymous (Quebec, Canada: Les Presses de l'Universite Laval, 2009), 18-21.
- 33 Cole and Brown, *Reconciling human and automated intelligence in the provision of occupant comfort*, 39-55.
- 34 Bill Bordass, Adrian Leaman, and Steve Willis, *Control Strategies for Building Services: the role of the user*, Anonymous Buildings and the Environment conference (BRE), 1994), 16-20.
- 35 RoperASW, *Americans' Low "Energy IQ:" A Risk to Our Energy Future*, Anonymous (Washington, D.C.: The National Environmental Education & Training Foundation, 2002)
- 36 Willett Kempton and Laura Montgomery, "Folk quantification of energy," *Energy* 7, no. 10 (1982): 817-827.
- 37 *ibid.*
- 38 *ibid.*
- 39 RoperASW, *Americans' Low "Energy IQ:" A Risk to Our Energy Future*,
- 40 Sarah Darby, *The Effectiveness of Feedback on Energy Consumption*, Anonymous (Oxford: Environmental Change Institute, 2006)
- 41 Woodruff, Hasbrouck, and Augustin, *A Bright Green Perspective on Sustainable Choices*, 313-322.
- 42 Darby, *The Effectiveness of Feedback on Energy Consumption*,
- 43 *ibid.*
- 44 Frans W. Siero et al., "Changing Organizational Energy Consumption Behaviour Through Comparative Feedback," *Journal of Environmental Psychology* 16, no. 3 (1996): 235-246.
- 45 Darby, *The Effectiveness of Feedback on Energy Consumption*,
- 46 Lawrence J. Becker, "Joint effect of feedback and goal setting on performance: A field study of residential energy conservation," *Journal of Applied Psychology* 63, no. 4 (1978): 428-433.
- 47 Jeannet H. Van Houwelingen and W. Fred Van Raaij, "The effect of goal-setting and daily electronic feedback on in-home energy use," *Journal of Consumer Research* 16, no. 1 (1989): 98-105.
- 48 Darby, *The Effectiveness of Feedback on Energy Consumption*,
- 49 Bill McKibben, "The Power of the Click," *Los Angeles Times* October 16, 2007
- 50 Jennifer Mankoff et al., *Leveraging Social Networks to Motivate Individuals to Reduce their Ecological Footprints*, Anonymous, (2007), 87-97.
- 51 A. Morris, "Reflections on Social Movement Theory: Criticisms and Proposals," *Contemporary Sociology* 29, no. 3 (2000): 445-454.
- 52 Florence Passy and Marco Giugni, "Social Networks and Individual Perceptions: Explaining Differential Participation in Social Movements," *Sociological Forum* 16, no. 1 (2001): 123-153.
- 53 Florence Passy and Marco Giugni, "Life-Spheres, Networks, and Sustained Participation in Social Movements: A Phenomenological Approach to Political Commitment," *Sociological Forum* 15, no. 1 (2000): 117-144.
- 54 Siero et al., *Changing Organizational Energy Consumption Behaviour Through Comparative Feedback*, 235-246.
- 55 Woodruff, Hasbrouck, and Augustin, *A Bright Green Perspective on Sustainable Choices*, 313-322.
- 56 *ibid.*

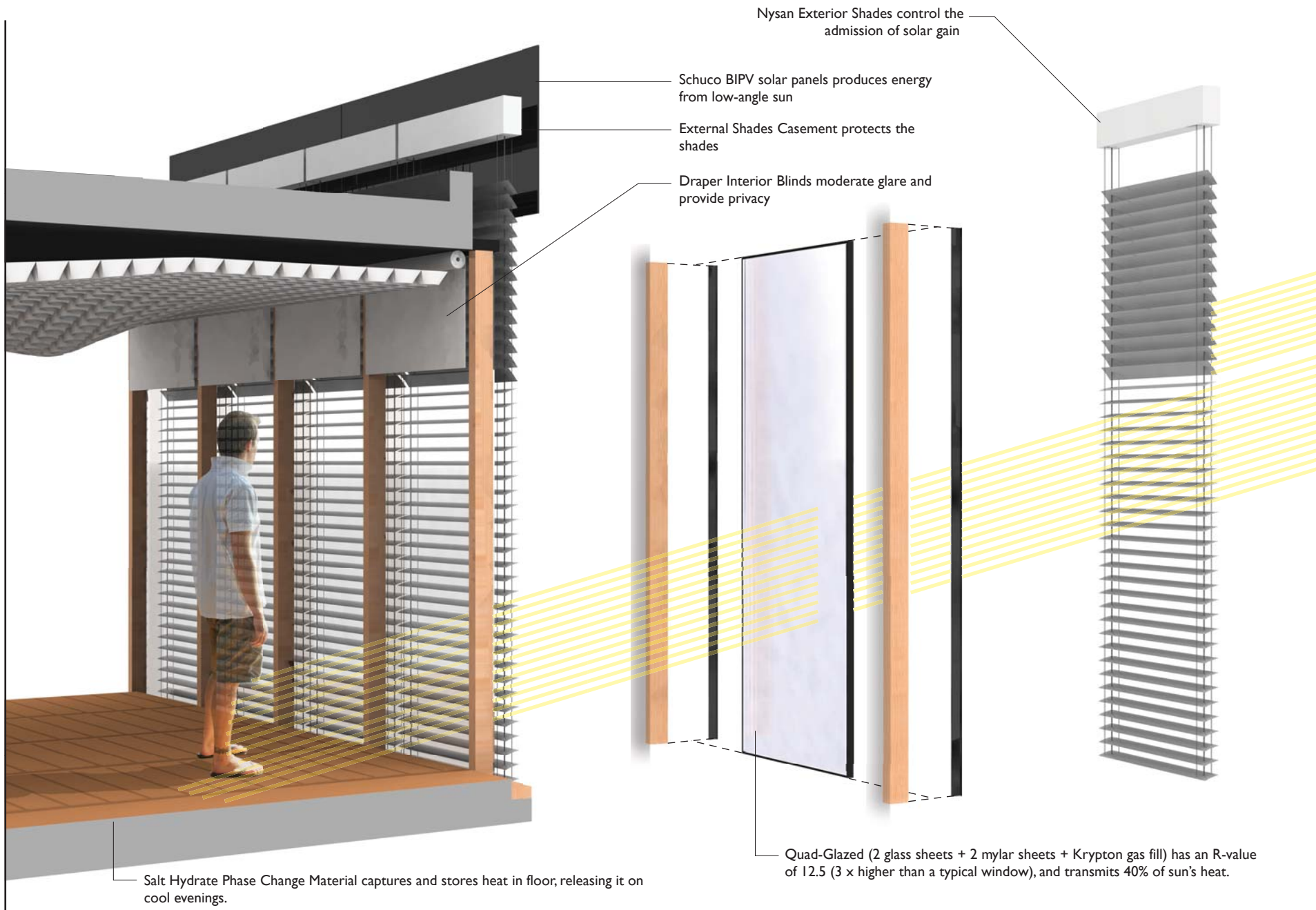

PART 2

ENVIRONMENTAL RESPONSIVENESS AND ENERGY EFFICIENT SYSTEMS The Design and Integration of the Distributed Responsive System of Skins

The North House's Distributed Responsive System of Skins is a hybrid passive and active building envelope system that transforms the highly glazed façade from an energy liability to a net energy resource. It makes use of passive solar principles to provide free heat in the winter and reduce cooling loads in the summer, but uses a strategy of active solar management to ensure reliable and consistent performance without placing a burdensome responsibility on the inhabitant. In this chapter I present the DReSS, documenting the process of its design in conjunction with the architectural form, projected energy performance, integration with the mechanical conditioning system, control logic, major components, and impact on architectural form. I then discuss the resulting architectural expression, examining the variable and nuanced relationship between interior and exterior and its implications for boundary and connection to surrounding landscape, privacy and spectacle, and daylight and views.

2.1 DESIGN PROCESS: Parallel development of North House and DReSS as a feedback-based process

Team North began the design process with an articulation of design objectives which identified the constraints of the project and set out ambitions for both the technical performance of the house and the desired quality of life offered to its inhabitants. Rather than beginning the design process with a predetermined formal idea onto which building technologies were applied, the team developed the building technologies in parallel with the design of the home, each informing and inflecting the other. To a certain extent, this design process mirrored the conceptual ambitions of interactive architecture and can be characterized as an on-going “conversation” between design ambitions, performance targets and a complex set of constraints.

Throughout the design process, the team made use of feedback mechanisms to evaluate design iterations and to suggest new avenues of investigation. These feedback mechanisms included energy modelling of components, systems, and the whole house; direct input from the fabricator on detailing and constructability; and the availability of technologies.

Facing Page
Figure 2.0: Illustration of the components of
the Distributed Responsive System of Skins

2.1.1 Design Objectives and Constraints

The design objectives that were identified by the team at the outset of the design process each had an implicit set of goals and constraints. Before beginning to propose solutions, it was important to understand each of these constraints and to identify where they presented opportunities for innovation.

High-Performance House for the Extremes of the Canadian Climate:

This objective conceptually identifies that the house should perform in the range of climatic conditions that are common to many parts of Canada: including very cold winters with low sun angles and short hours of daylight; hot humid summers with high sun angles and long hours of daylight; and highly variable shoulder seasons which can swing from one extreme to another within a matter of days. For the purposes of building a working prototype that was appropriately suited to its final location, Team North tailored the design to the particular conditions of the Toronto region. Nonetheless, the applicability of the chosen technologies to other northern regions, with some reconfiguration, was always a priority consideration.

We defined high-performance within the above climate conditions as meeting these goals:

- Use very low levels of energy to heat, cool, ventilate, light, and otherwise operate the building.
- Maintain an interior environment that is healthy and thermally, acoustically, and visually comfortable.
- Generate a surplus of energy over an annual cycle.

Distributed Responsive System of Skins (DReSS):

This objective takes inspiration from the Canadian custom of dressing in layers, to develop an envelope system that distributes discreet functions across a series of elements in order to perform well in the wide range of conditions that characterize our climate region.

The suggested functions of this layered building set of elements are typical of functions met by traditional building envelopes. However, by conceptualizing the envelope as a composition of discreet functional elements - rather than as known wall assemblies - we were able to first specify the desired performance, and then derive the most appropriate format. These required functions include but are not limited to: insulating; admitting, blocking or retaining solar heat gain; admitting, blocking or distributing daylight; admitting or blockings

views to the exterior; regulating the movement of air and moisture; structurally supporting the building; and generating power.

Adaptive Living Interface System (ALIS):

This objective recognizes the gap between the complex high-performance technologies of the North House and the typical inhabitant's ability to operate them. It identifies the need to provide an interface between inhabitant and technology, to make it easy for the inhabitant to operate these systems intelligently and effectively.

We set the following goals for the interface system:

- Provide appropriate balance between automation and user control.
- Support tasks that are appropriate to the inhabitant's needs.
- Provide easy access and navigation to control and information.
- Provide meaningful feedback to the inhabitant.
- Integrate technology with the lifestyle of the inhabitant.
- Provide personal and social incentives to conserve energy and other resources.

The resolution of these goals will be discussed in greater detail in Part 3

Holistic Solar Living:

This objective is related to the above objective of creating a high-performance house for the northern climate. However, it deals explicitly with enhancing the quality of life in these climatic conditions by encouraging the inhabitant to enjoy the solar and seasonal cycles by providing a domestic environment that varies its character to suit the requirements of the season.

We identified the following goals:

- Provide a high degree of daylight penetration as well as the ability to easily control glare and interior lighting conditions, to all of the living spaces in the home.
- Provide flexible exterior living space to support a variety of outdoor activities when the weather permits.
- Provide gardens to support food production and strategies for water management.
- Provide visual and physical connection between indoor and outdoor living space, and views to the surrounding landscape.

Customizable Components:

This objective began with pragmatic concerns for meeting the unique logistical requirements for assembling the North House on the National Mall in only seven days. It also recognized a complementary opportunity to use the project to test strategies for mass fabrication and mass customization. An additional benefit of this type of strategy is that it will result in easily replaceable components, which will allow the building more flexibility in its future life as a laboratory for long-term testing and monitoring of these technologies.

Based on these concerns and opportunities we identified the following constraints:

- All components must be able to be transported on a truck across provincial and state borders without special permitting and therefore, must be of appropriate size and weight to do so.
- All components must be able to withstand being lifted and moved several times without being damaged (with temporary reinforcement if necessary).
- All connections between components must be reversible.
- All components must meet performance criteria in permanent as well as temporary installation.

The resolution of this objective is discussed extensively by Chloe Doesburg in her Master's thesis *The North House as Component Based Architecture*.

Solar Decathlon rule compliance:

Participation in the Solar Decathlon competition imposed several constraints which were non-negotiable for the project team. These include:

- The house footprint is limited to 800 sq. ft. measured to the exterior edge of the envelope.
- The program is specified as a home for two adults. It must include space to entertain a dinner party and film screening for 8, some accommodation for home office space, and all modern appliances.
- The house must be 100% solar powered and grid tied.
- Height is limited to 18 ft. measured from the highest point at grade on the building site.
- Bearing capacity of the foundations on the soil is limited to 1,500-psf (71.8-kPa)
- Penetration of the ground is limited to 18" depth for the sole purpose of inserting grounding rods or structural ties.

2.1.2 Design Integration

Each of these design objectives, goals, and constraints were critical in developing the final design of North House. Ultimately the development of DReSS itself had the greatest impact on the overall form, orientation, interior layout, and outward architectural expression of the project. Below is a brief overview of the major design investigations that led to the final implemented version of the North House and the DreSS. Though these are presented here as a neat sequence of studies and proposals, in actuality the design process was far more iterative with many streams of research and design operating in parallel each informing and being informed by the others.

Modelling Dynamically Controlled Exterior Shading Devices

Before any design visualizations began, research by team member Bartosz Lomanowski, at the University of Waterloo Department of Mechanical and Mechatronic Engineering, was presented which demonstrated the efficacy of dynamically controlled exterior shading devices in managing solar gains.¹ This work developed a building energy simulation tool to model the effect of exterior shading devices on building cooling loads. The simulations suggested that dynamically controlled exterior shades, when coupled with a high-performance glazing system in a well insulated airtight building, can allow highly glazed facades to act as net energy producers rather than energy liabilities.

This research presented a challenge to the accepted energy standards which restrict window-wall ratio to 40% or less, as windows are commonly held to be the least energy efficient part of an envelope assembly. Typically they have low thermal resistance and can be prone to air leakage, both of which contribute to increased heat loads due to daily net heat loss, and increased cooling loads due to uncontrolled solar gain. However, unlike opaque envelope assemblies, glazing is able to transmit solar radiation and provide heat during the day. If the solar gains of the windows are greater than the thermal losses on an annual basis, the window can be considered a net heating-energy supplier. This can produce a building that is highly prone to overheating in cooling season and therefore requires careful control of incoming solar radiation to shield the building from increased cooling loads. Building energy models evaluated in ESP-r demonstrate that dynamically controlled slat-type shades can reduce the cooling load by 75% during cooling periods (in the best case scenario of fully closed slats) while reaping the benefits of free solar gain in heating periods. This strategy is especially significant given that space heating demands dominate all other energy end-uses in buildings in northern climates.

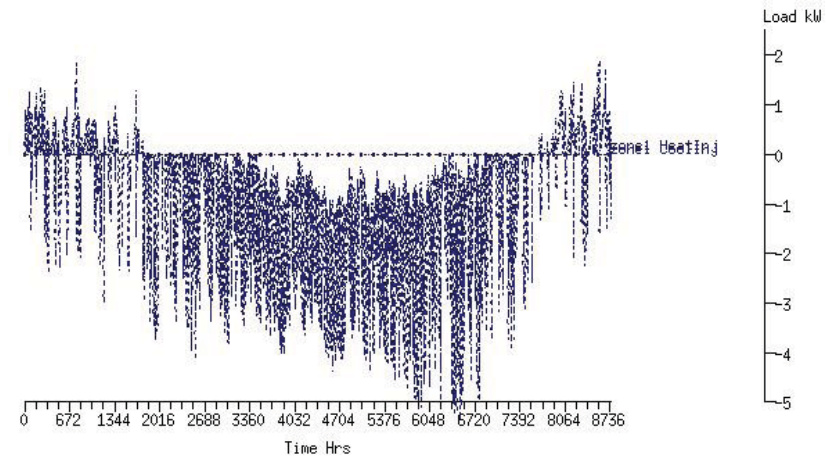

Annual Heating and Cooling Loads - NO SHADING.
Sensible Heating Load = 1486kWh/y Sensible Cooling Load = 8200kWh/y
Total Space Conditioning Load = 8770kWh/y Total Load per unit area = 143.3 kWh/yr/m²

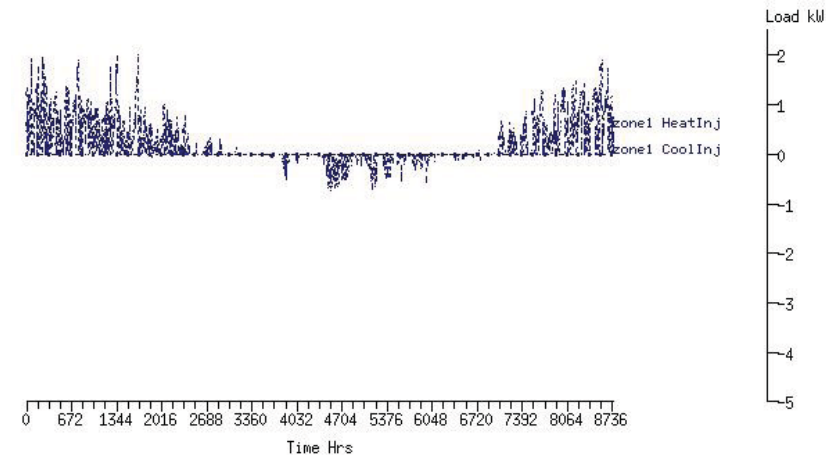

Annual Heating and Cooling Loads - DYNAMIC SHADING
Sensible Heating Load = 1572 kWh/yr Sensible Cooling Load = 1838 kWh/yr
Total Space Conditioning Load = 3410 kWh/yr Total Load per unit area = 55 kWh/yr/m²

Figure 21: The effect of window shading is examined by considering a base case with no shades, and a case with dynamic operable louvered shades. Both cases employ the use of Phase Change Materials embedded in the floor and ceiling. Figure XX and XX show the annual heating and cooling loads for the two scenarios. It is evident that the best-case aggressive shading strategy can effectively remove most of the sensible cooling load. In reality, occupant behaviour will most likely increase the cooling loads from what is presented here.

Type	Quadruple Glazed	Double Skin: Triple-Double	Double Skin: VIG
Schematic			
Centre of Glass R-value	R-13	R-15	R-18 ~ 20
SHGC	0.44	0.42	0.3 ~ 0.4 (TBD)
Visible Transmittance	0.48	0.54	0.5 ~ 0.6 (TBD)
% Annual Savings	-	5%	48%
Venting	None	Maybe Required (note: venting poses significant challenges)	Maybe Required (note: venting poses significant challenges)
Thickness	Standard 1.5" IGU	1.5" + 1" = 2.5" IGU + 3" gap = 5.5" Double Skin	1" Minimum 3" Maximum with Venting
Operability	Easy Standard operable window design will do	Custom Frames Required (very bulky)	Custom Frames Required (however, may not be bulky, especially if venting is not required)
		Potentially very difficult if venting is required	Potentially very difficult if venting is required
Maximum Size	Probably Full Façade (Full Sheet)	Probably Full Façade (Full Sheet)	4 ft x 6 ft Will require façade to be panelized Will lead to further thermal bridging
Construction	Standard, commercially available	IGUs are commercially available, however, double skin frame needs to be custom built	VIG inherently have greater edge losses due to lack of spacer (soldered glass)
Qualitative Evaluation	Full Sheet Thinner than Triple-Double Standard	Full Sheet Thick 2.5" to 5.5"	Panelized Thin New
Wow Factor	Minimal, Standard Product	Minimal, essentially stacking pieces of glass to achieve greater R-value	Very high, new product, can potentially achieve 5 times the insulation of a double glazed window with the same thickness (with no venting)
Testing	Will be carried out for Quad and VIG glazings to determine glass temperatures, decision on glazing will have to be re-evaluated following results of the experiment Testing will be carried out during September 2008 at UW		

Figure 2.2: Properties of the shortlisted Glazing Systems based on early glazing simulations.

Based on the desire for generous day-lighting, views and connection to the exterior, as well as low-energy operation of the building, the team saw this research as a valuable opportunity to balance the spatial and aesthetic benefits of a highly glazed façade with an innovative energy saving feature. Developing an appropriate exterior shading system, along with the requisite controls and an accompanying glazing system to meet appropriate performance requirements, became the central challenge of the North House design process.

Modelling High-Performance Glazing Systems

The success of the highly-glazed façade with dynamically controlled shading as a net energy supplier relies on very specific properties in the glazing system. It must have an optimized balance between thermal resistance and fraction of solar heat transmission in order to minimize heat loss during winter and nighttime conditions and admit solar gain in the day. Early in the design process, the team performed preliminary annual building simulations in ESP-r to determine performance targets for the glazing. These simulations demonstrated that in order for the overall system to be considered to be a net energy supplier the glazing system must be insulated to a minimum value of R6 (U-value < 0.99w/m2K) and admit solar gain at a minimum Solar Heat Gain Co-efficient (SHGC) of 0.4. Though not required for heating or cooling, a Visible Transmittance (VT) of >0.4 was also set as a target for providing high quality day-lighting.

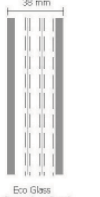
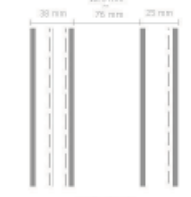
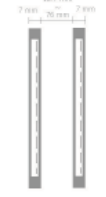
The engineering team modelled over 60 glazing combinations with different types of glass, films, coatings and configurations ranging from double-glazed to quintuple-glazed, and combined in single- or double-skin façade systems with varying cavity depths between them. They used the Lawrence-Berkeley National Laboratory's WINDOW5 and the University of Waterloo's VISION4 modelling programs to analyze the spectral properties, thermal resistance, and surface temperatures. Their investigation suggested three top choices for glazing systems that would suitably meet these requirements: a quadruple glazed IGU with two layers of glass and two mylar interlayers; a double-skin system composed of a double glazed IGU and a triple glazed IGU (2 layers glass + 1 interlayer) with a 76mm cavity; and a double skin system composed of two Vacuum Insulated Glazing Units. These three options were each investigated extensively and considered according to their ability to be integrated with frames and operators, product availability, impact on floor plan, structural stability, and other construction related concerns.

Despite specifying a high-performance glazing unit, most of its performance may be undermined through a poorly designed conductive frame. Due to time constraints in the Solar Decathlon assembly and disassembly periods, the glazing and frame system needed to be assembled in 6-8 hours, leading the team to favour stick-frame construction and avoid any permanent sealants. To balance these concerns, the team undertook a detailed iterative investigation of curtain wall mullion design. The engineering team used THERM software to model over 35 combinations of window offset depths, layers of insulation, and edge spacer materials.

Study of Building Orientation and Form

A compact floor plan was preferred to minimize the ratio of envelope to floor area, thus reducing space cooling loads while also providing a more flexible floor plan. Two building orientations were modelled to test the effect of an east-west versus a north-south orientation. Both scenarios contained identical assumptions for performance of construction assemblies, percentage of glazing area, shading control, ventilation, heating and cooling control and solar distribution. Interestingly, there are no significant differences between the two orientations in terms of heating and cooling loads and passive performance. However, the east-west orientation provides more south-facing area which is critical for optimizing the performance of PV and solar thermal collectors.

Study of the Sun-Space

An early design iteration proposed an unconditioned ‘sun-space’ on the south of the building as an energy saving feature. This would serve as an airlock entry vestibule in the winter or when air conditioning is used, but would become part of the living space when the house is operating in passive mode. Though this feature would reduce the mechanically conditioned floor area, it was found to have marginal energy saving benefit in a building of such a small scale, especially when the high performance targets set for the glazing and shading systems would allow passive heating and cooling to easily offset the additional load of conditioning the entire floor area.

Exterior Shading Design Investigations

The design team explored countless different technologies and strategies for the dynamic exterior shading layer of the DReSS. The team considered numerous types of horizontal and vertical operable louvers, mounted directly to the building, or to sliding or pivoting frames. We examined a range of profiles and dimensions of slats and fins made from a laminated glass, plastic,

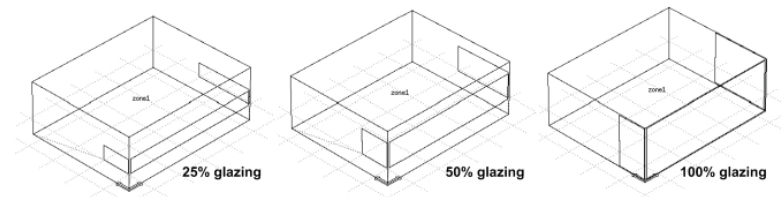

Figure 2.3: Volumetric Diagram illustrating the building energy models constructed to compare passive heating and cooling performance of varying percentages of glazing. Given that the glazing system can be considered a net heating energy supplier, the configuration with most glazing returns the best results.

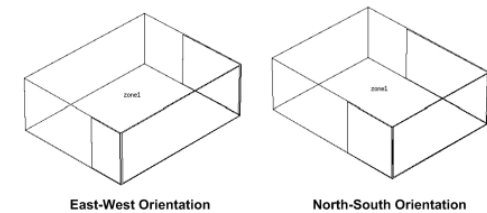

Figure 2.4: Volumetric Diagram illustrating the building energy models constructed to compare passive heating and cooling performance of a house oriented on the North-South axis v. an East-West axis.

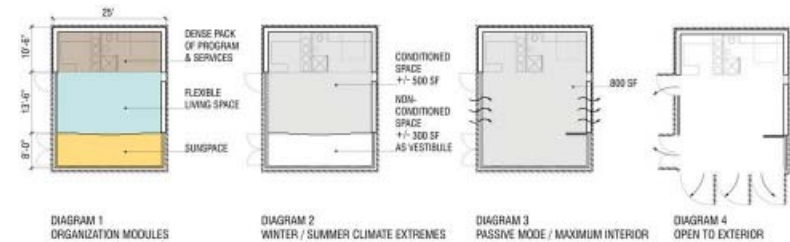
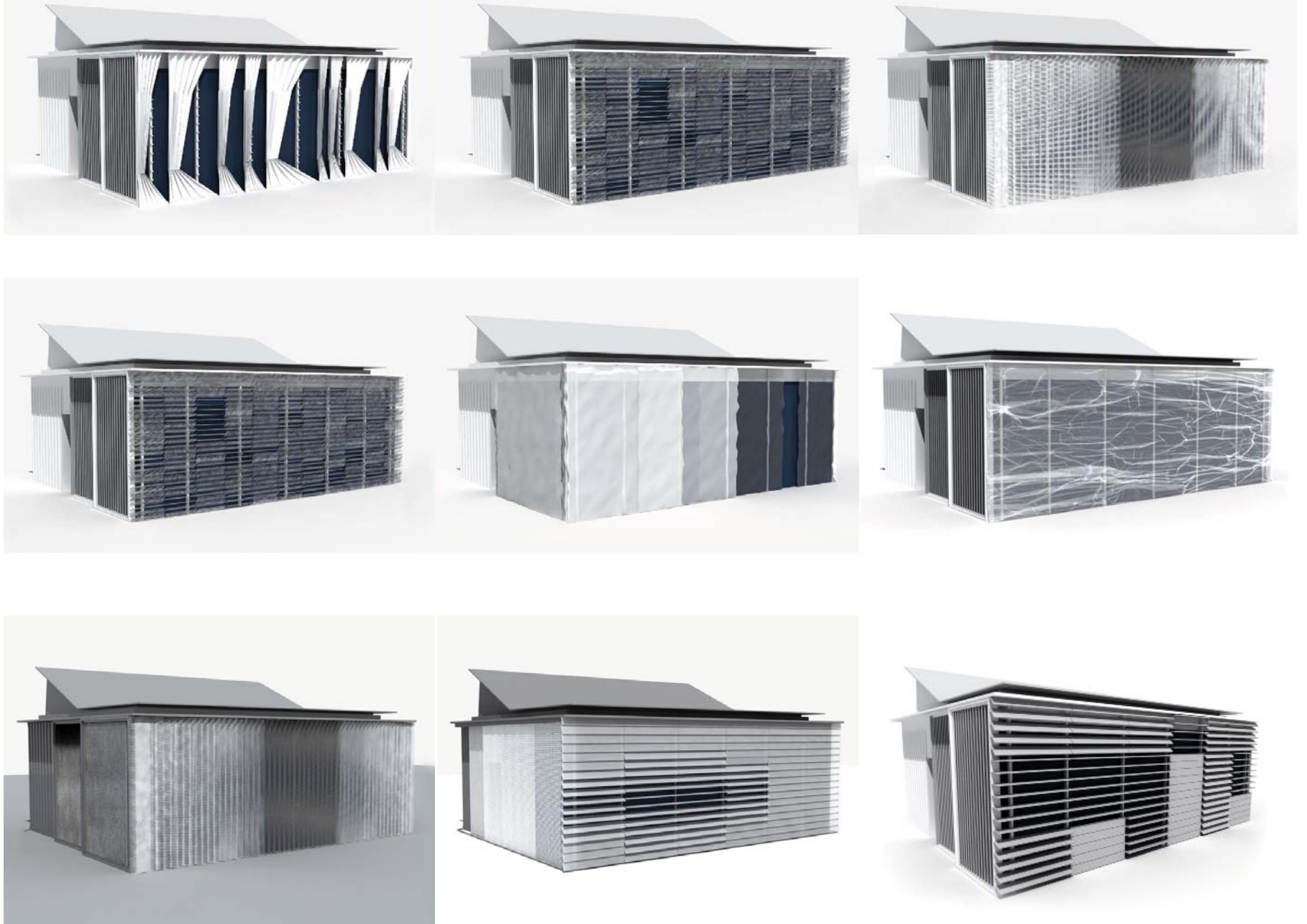
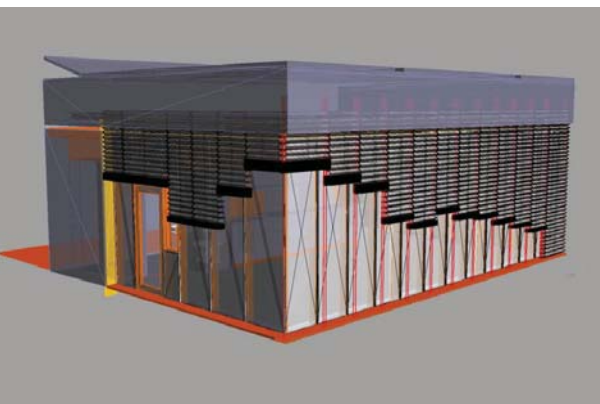
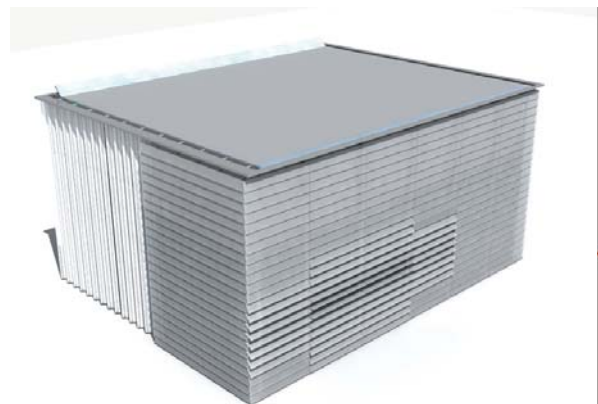
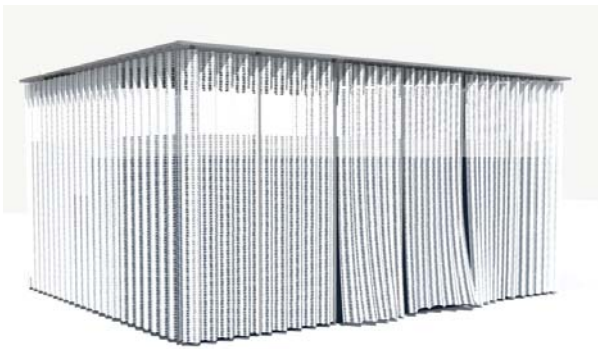
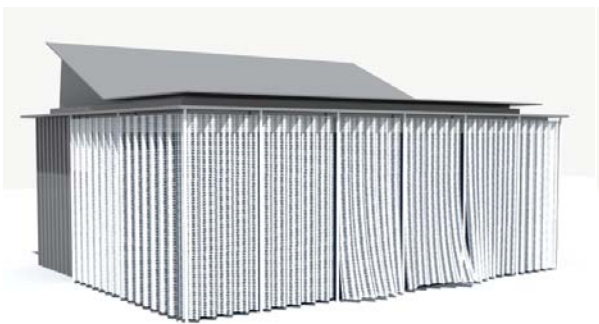

Figure 2.5: Plan diagrams illustrating an early design proposal for an unconditioned ‘sun-space’ that would act as an airlock vestibule when mechanical heating or cooling was required, but expand the living space when the house was operating passively.

Visualizations of Exterior Shade Design Investigations (Figure 2.6)





Visualizations of Photovoltaic Array Design Investigations (Figure 2.7)

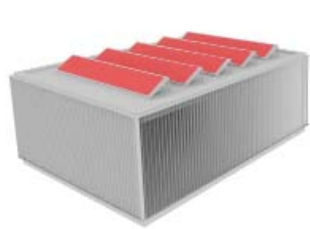

Fixed Arrays at 45°

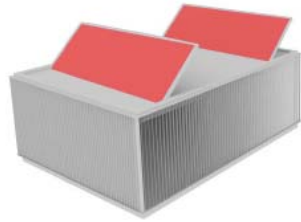

Fixed Arrays at 45°

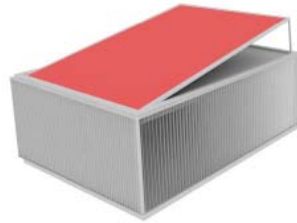

Fixed Low Slope Array (within 18°)

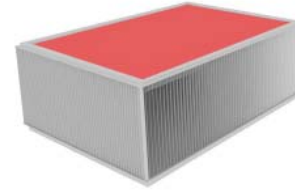

Fixed Flat Array

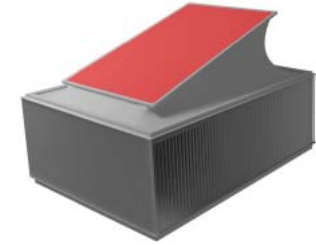

Array with 1-Axis Adjustable Slope

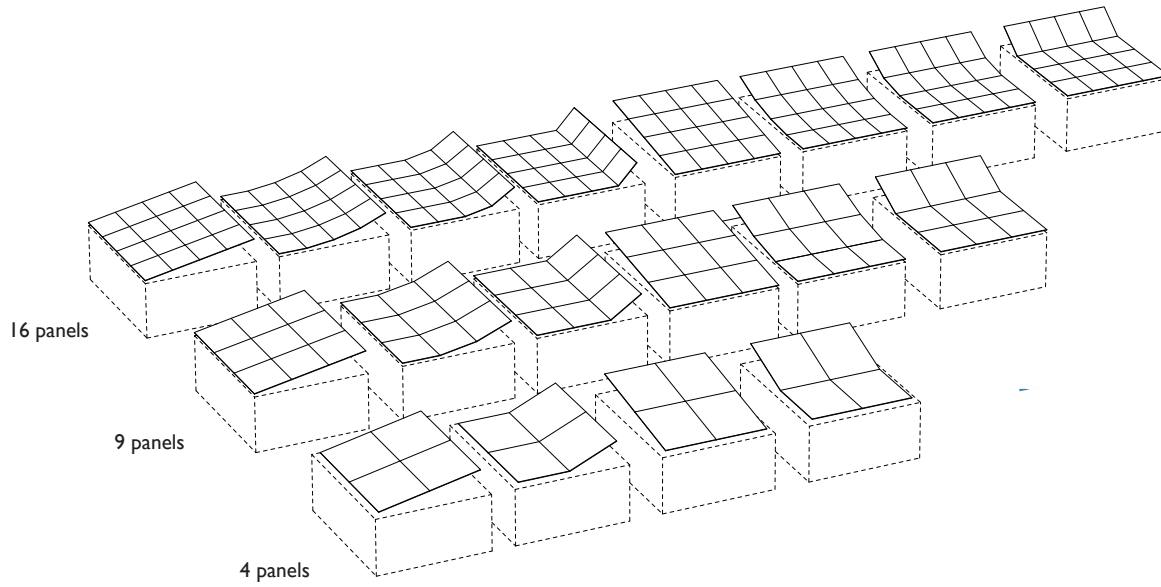

16 panels

9 panels

4 panels

Articulated Array with 2-Axis Adjustment



polycarbonate, or aluminum. We also investigated more experimental options such as exterior textiles made from metal, nylon, or plastic, which could be folded, draped, stretched and rolled to modulate solar penetration. These options included fully custom solutions, modifications to existing products, and existing or developing proprietary products.

The design team had an early ambition to integrate PV technology into the shading device itself in order to maximize surface area available for PV electrical production. This ambition recognized that the PV would not be optimally oriented at all times, but anticipated a future in which the cost of PV technologies would be significantly reduced, thus making broader application more feasible.

PV Array Configuration Investigations

Simultaneously to the extensive investigation of exterior shading devices, Team North also undertook rigorous investigation into a variety of PV configurations on the building. These options were constrained by the 18 foot height limitation during the Solar Decathlon, as well as the accepted reality of having snow coverage on rooftop arrays, regardless of slope, which will inhibit their performance throughout much of the winter.

Preliminary options considered by the team were quite varied and included a fixed single slope rooftop array; a series of arrays at a 45° angle; an array with an adjustable slope inspired by the Westfalia camper van; an articulated array which was adjustable in two axes; and a fixed flat array with a PV fascia to the south, east, and west. Ultimately, energy simulations conducted in TRNSYS determined that adjustable roofs had little measurable benefit within the height restriction of the competition. The simulations suggested that the single most important factor in determining overall PV electrical production was the total PV area. Thus the fixed flat rooftop array supplemented with PV fascia and side panels was chosen as the ideal solution, providing both a large PV area, and a range of orientations which allows for energy production throughout the year.

As discussed above, there was also considerable effort to integrate PV technologies into the operable shading devices. Integrating photovoltaics onto horizontal louvers creates a condition of self-shading, in which each slat shades the slat beneath it. The properties of crystalline silicon photovoltaics are such that partial shade on a module reduces the operating efficiency of

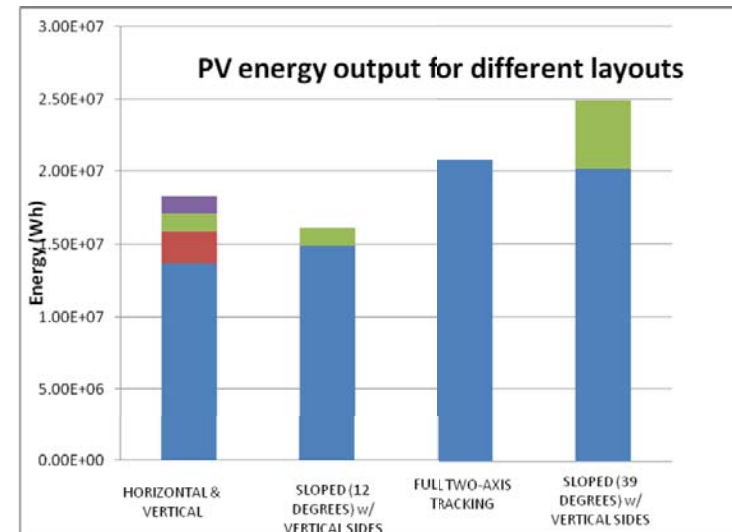
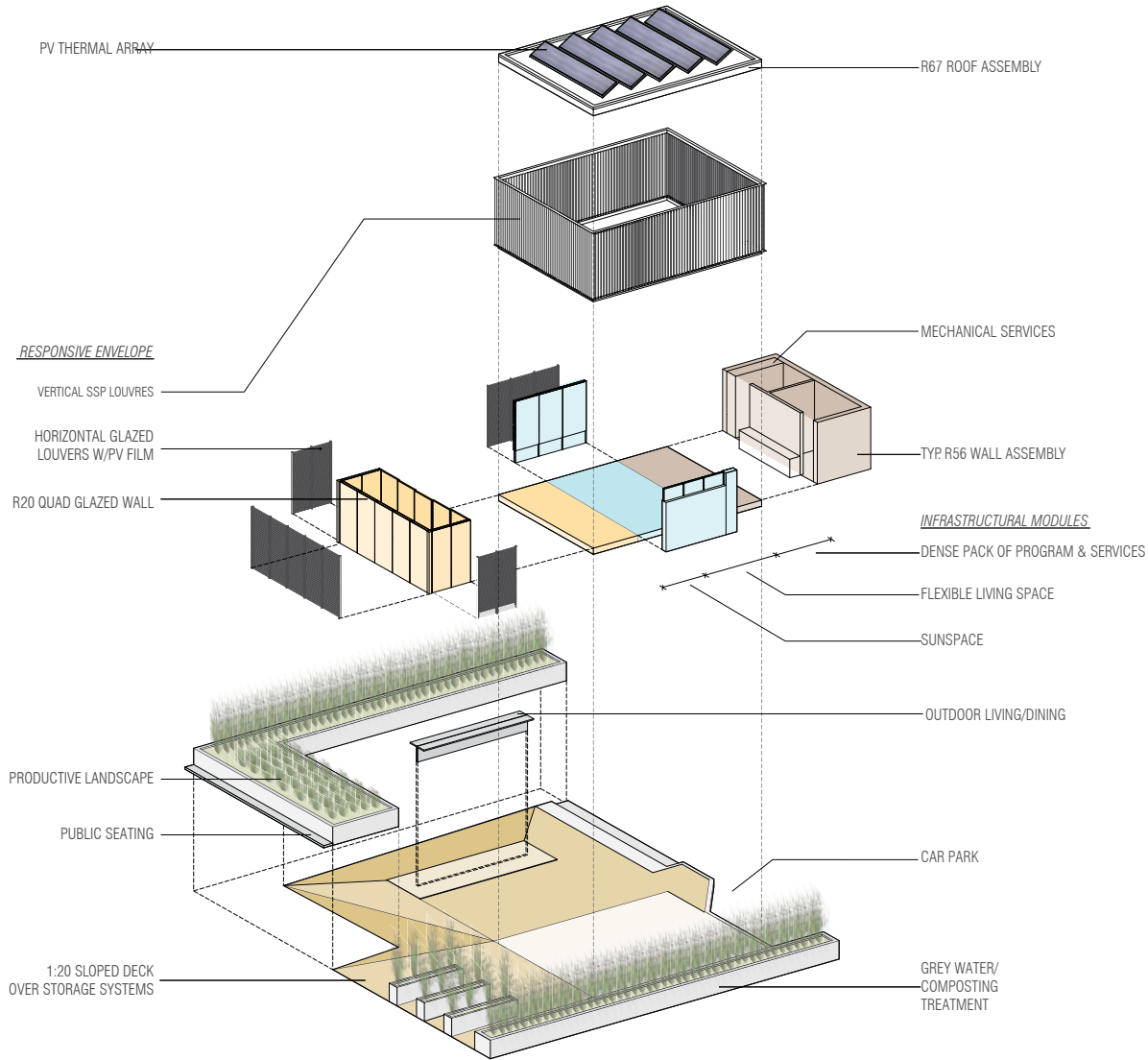

Figure 2.8: An initial comparison of yearly energy output for four different PV configurations. For all cases, the blue part of the columns is the roof output. For the first column, the red is the output from the south facade, and the green and purple are the outputs from the east and west. The green part of the second and fourth columns represent the energy output of the east- and west-facing photovoltaics.

The first column consists of a horizontal roof covered in photovoltaics and a 5 foot high band at the top of the east, west and south facades. The second column represents a roof covered in photovoltaics but tilted 12 degrees towards the south (maximum tilt to stay within solar envelope) with side “PV triangles” (if looking at the west or east facade, the roof creates a triangle with the horizontal plane, the triangle would be filled with PV). The third column represents an area the size of the roof tracking the sun in two axes (zero angle of incidence at all time). This scenario would be almost impossible to produce due to the size of the roof (and it would not fit in the solar envelope). The last column is the same as the second, but for a greater slope of the roof. Columns three and four could not be used during competition but are good for comparison purposes.

Exploded Axonometric Diagram of November 2007 Design Iteration (Figure 2.9)



EXPLODED AXONOMETRIC OF PRIMARY COMPONENTS

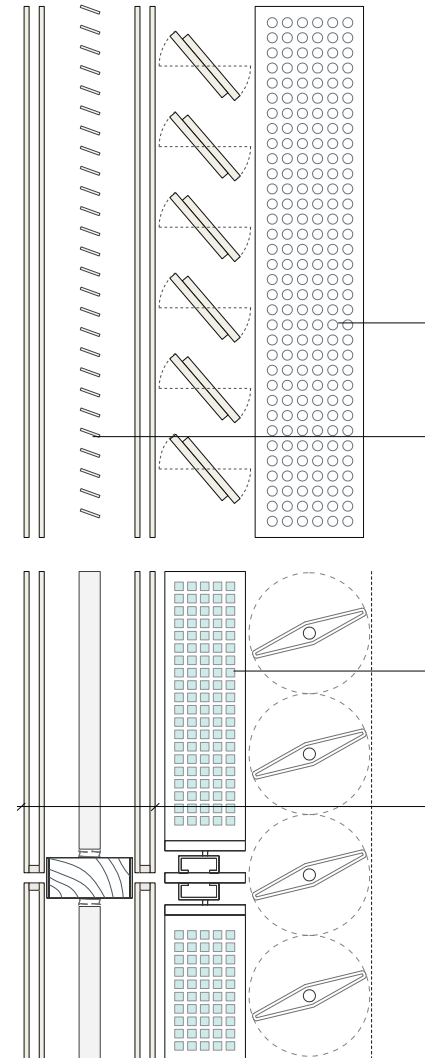

Exploded Axonometric Diagram of June 2008 Design Iteration (Figure 2.10)

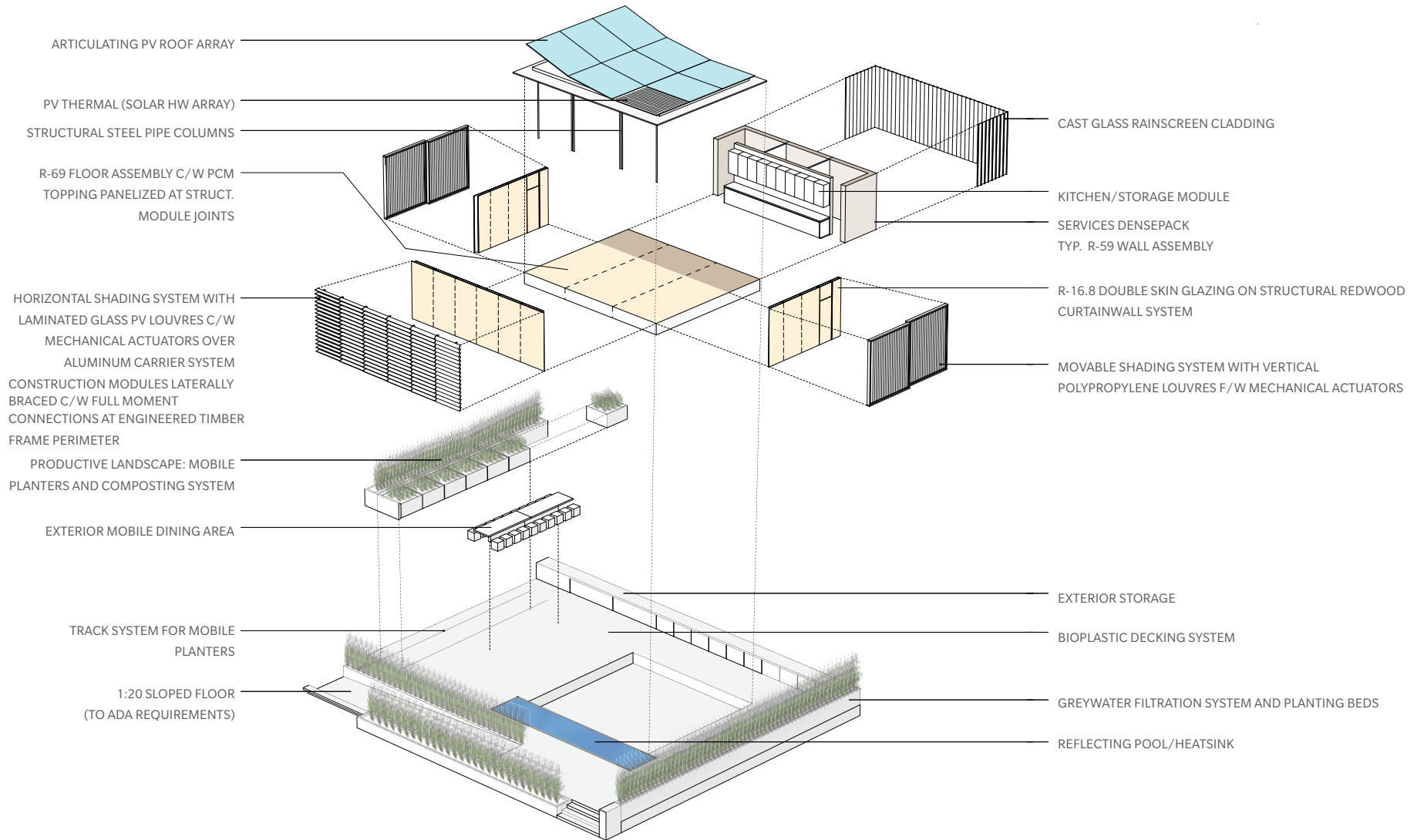

Exploded Axonometric Diagram of December 2008 Design Iteration (Figure 2.11)

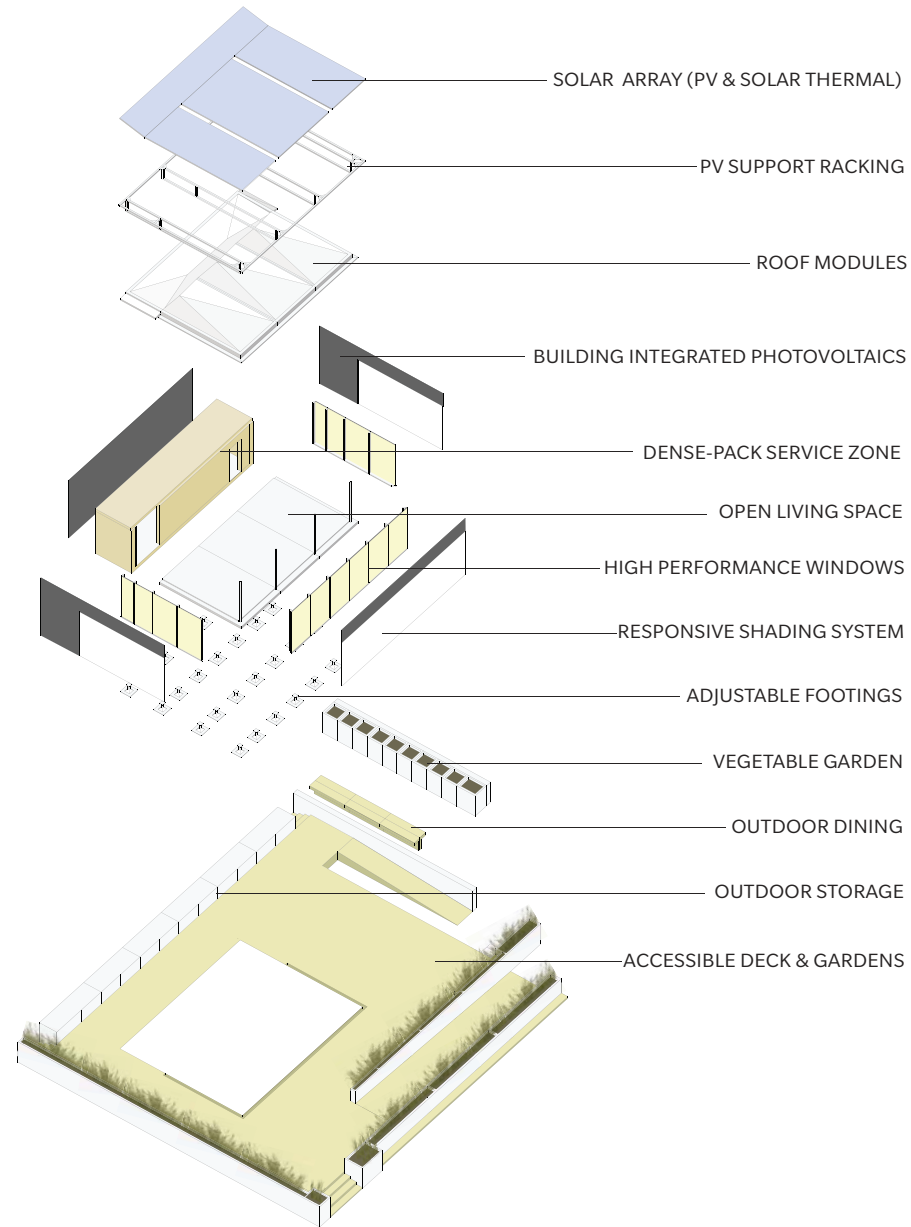

the entire module beyond simply impeding the performance of the shaded portion. This results in a system of very low efficiency and considerable design complexity. Furthermore, throughout most of the year the optimal orientation of slats for the purpose passive solar management is directly opposed to their optimal orientation for power generation.

Die-sensitized solar cells, as well as Amorphous, or thin-film silicon photovoltaic technologies seemed to offer a promising option for integration with exterior shading. Both of these cell types operate more efficiently in conditions of partial shade or in indirect light than crystalline silicon photovoltaics, and are also quite flexible. However, at the time of investigation the technology was not sufficiently robust for application on a mobile exterior device.

Eventually it became clear that integrating PV production with solar shading would compromise the performance of both systems. With the decision to include vertically mounted PV on the fascia and building envelope, the team elected to separate the PV production and solar shading functions in order to allow each to function more optimally.

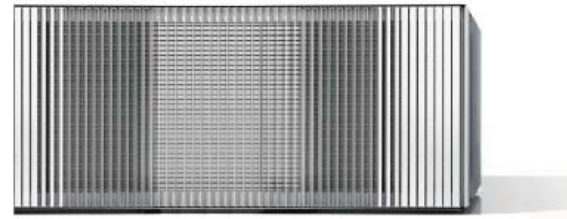

Figures 2.12, 2.13, 2.14: Renderings illustrating design iterations at various stages of development

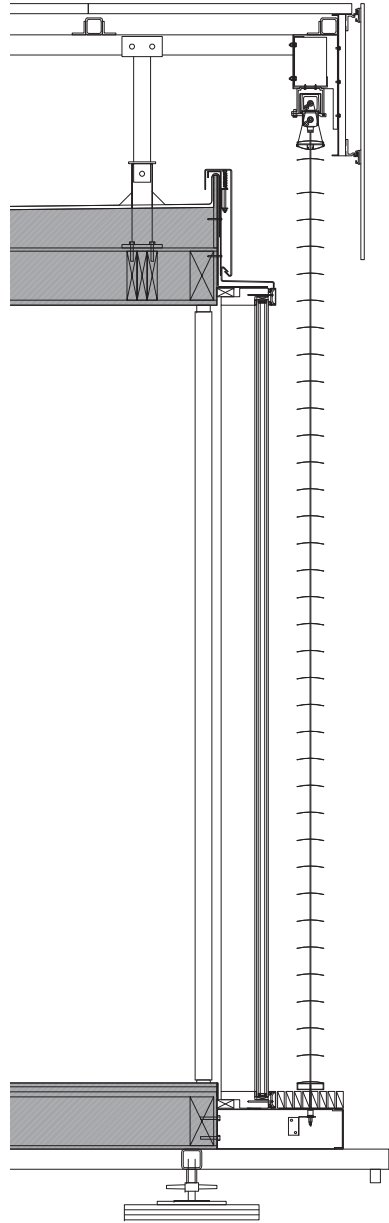

Facing Page
Figure 2.15: Final Floor Plan (not to scale)

This Page
Figure 2.16: Wall Section at DReSS with
exterior shades extended (not to scale)

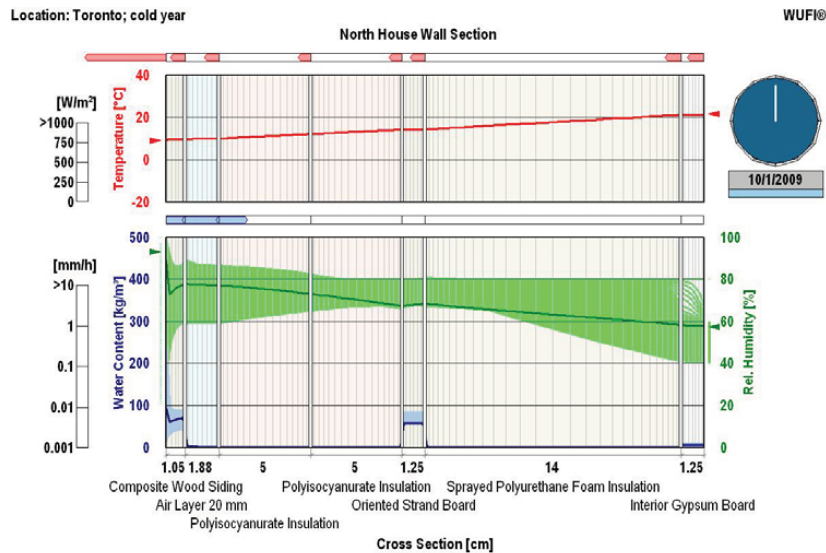

Figure 2.17: Hygrothermal Performance of the North House Wall Assembly analysed with WUFI

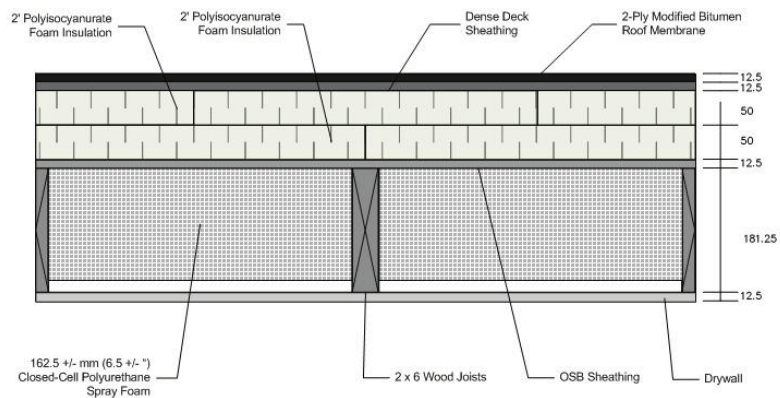

Figure 2.18: Insulated roof panel assembly

2.2 LAYERS OF THE DR_eSS AND THE INSULATED ENVELOPE

The final configuration of the building envelope consisted of two assembly types which met very different requirements in the building. The Distributed Responsive System of Skins enveloped the open living space on the south, east, and west facades, while an insulated double-stud wall assembly surrounded the ‘Densepack’ service module on the north end of the building.

The DR_eSS consists of retractable Venetian-blind style exterior shades; a quadruple-layer glazing system with custom wood frames; Phase Change Material installed beneath the finished floor; interior roller blinds; and a light- and sound- diffusing fabric ceiling.

2.2.1 Insulated Envelope Assembly

The Insulated Assembly forms the envelope on the exterior walls of the Densepack as well as the roof and floor panels. In order to achieve the very high thermal resistance values that are required for cold-climate low-energy buildings, a double-layered stud wall system was carefully designed to avoid thermal bridging, with 2x4 offset from 2x6 FSC-certified wood studs to create a continuous 254 mm (10”) thick assembly with no through-and-through thermal bridges. The cavities were filled with R7.2/inch polyisocyanurate spray-foam insulation to create an airtight R72 enclosure. This double-layered offset system allowed the structural requirements for interior and exterior to be treated separately, allowing the 2x6 interior layer to function as the structural support for the densepack, while the exterior 2x4 layer acted as structural support for the cladding system and was spaced to match the mounting brackets.

Hygrothermal analysis performed with WUFI modelling software suggested that a fully vented rainscreen wall system should be used for the vertical faces of the assembly. This allowed for the use of Building Integrated Photovoltaic panels as the exterior cladding layer on the east and west walls. The north wall, where BIPV would be of little value, was intended to be clad in black back-painted glass panels to visually match the BIPV, but due to last minute deficiencies in the product, it was clad in black painted plywood panels.

The roof panels were framed with 2x8 joists and filled with the same spray-foam fill and an additional layer of continuous sloped insulation, with an average thickness of 100mm (3.9”) creating a total thermal resistance of R70. Floor panels were framed with 2x8 with spray-foam fill to achieve a

total thermal resistance of R57 and are intended be installed on an insulated crawl space upon permanent installation. To maintain air- and water-tightness during the temporary installation, compressive foam gaskets at 80% compression were installed at joints.

2.2.2 Building Integrated Photovoltaics (BIPV)

The Building Integrated Photovoltaics applied to the south, east, and west facades of the building were custom built for this project. They consist of black, mono-crystalline, back-wired silicon cells encapsulated between a tempered safety glass on the front face, and black back-painted glass on the back. These frameless panels were affixed to the building envelope with a two-part extruded aluminum mounting system. One extrusion was mechanically fastened to the structure of the building while the other was adhered to the BIPV, and the two parts snap together.

2.2.3 Exterior Shades

Venetian blind style exterior shades were selected as the most appropriate shading option with two important benefits over all of the others: 1) the shades can easily and automatically be fully retracted from the face of the building to admit maximum solar penetration, daylight, and views; and 2) the slats can be rotated to a range of almost 180° allowing them to be positioned in parallel with the sun's rays, which results in far greater opportunities for solar control.

These shades were an existing proprietary product, an advantage that the team favoured for its reduced design complexity as well as the reduced risk of failure. However, the North House shades were modified to contain two motors to enable individual rotational control of an upper clerestory zone of the shade. One motor controls the slat rotation of the upper zone of the shades while the second controls the slat rotation of the lower zone and the retraction of the entire shade. Slat rotation can be controlled to a precision of roughly 5°, and shade extension can be controlled by percentage.

These shades are intended for exterior operation and have been used widely in Germany. The 4" slats are black powder-coated aluminum and are held in place by lightly tensioned cables.



Figure 2.19: Detail of Building Integrated Photovoltaic Panel at south fascia, and deployed exterior shades.

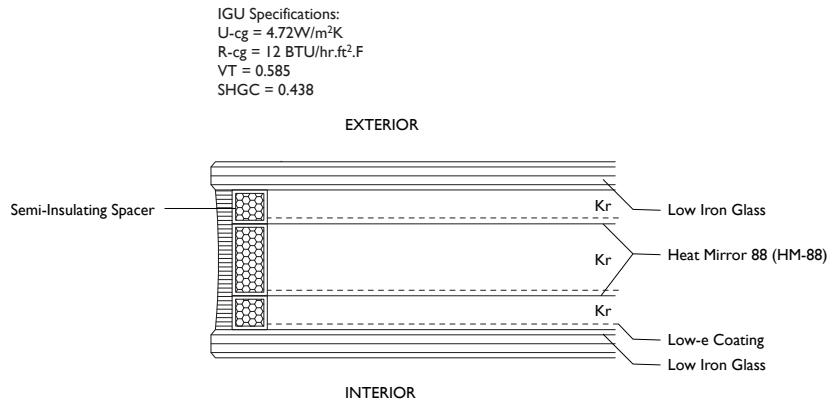

Figure 2.20: Composition of the Insulated Glazing Unit

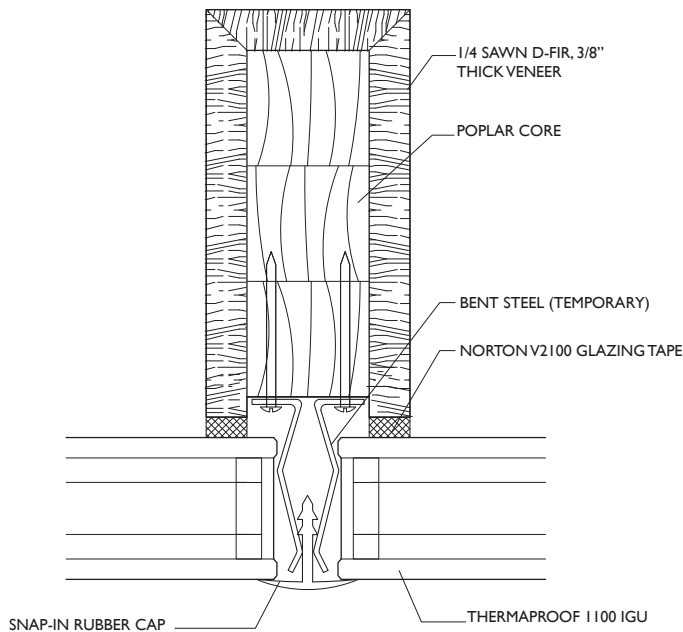

Figure 2.21: Detail of a the wood curtain wall system at mullion. Due to time constraints for the Solar Decathlon temporary steel inserts were used. These will be replaced with fibreglass or a high-density plastic for permanent installation

2.2.4 Insulated Glazing Unit and Wood Frame

Based on extensive energy modelling and constraints related to product availability and constructability the chosen IGU was a Quad-Glazed Krypton-filled unit comprised of two 6.5 mm sheets of clear low-iron glass sandwiching two sheets of Heat Mirror 88 (HM-88) mylar films with low-emissivity (low-E) coatings on glazing surfaces 3, 5, and 7 (see figure x). The coatings are a soft-coat low-E with emissivities in the order of 0.004, 21 times lower than clear glass.² Low-E coatings minimize long-wave thermal radiation transfer across the cavity which typically accounts for about 60% of the thermal transmission in typical IGUs.³

Striking the right balance between thermal resistance and solar heat transmission is challenging when using a multilayered IGU. To optimize this balance, HM-88 was chosen over films with lower emissivities for its clarity and solar transmittance while a lower emissivity was chosen for surface 7. Krypton gas fill further reduced convective heat transfer across the IGU. Krypton is a denser noble gas with lower convective heat transfer properties compared to air, and it has an optimal cavity width of 9mm, as opposed to 12.7mm for minimizing convective heat transfer. Perhaps counter-intuitively, reducing the cavity width increases the overall thermal resistance while also reducing the overall thickness of the IGU. This Quad-Glazed IGU has a Centre-Glass insulating value of R12, Solar Heat Gain Co-efficient of 0.404, and Visual Transmittance of 0.543⁴

Special attention was paid to the edge of the IGU, which is the least thermally resistive portion of an IGU. The particular IGU that the team selected is typically manufactured with a highly conductive steel spacer to hold the mylar films taut. In order to improve the thermal resistance of the spacer, the team worked directly with the manufacturer to substitute a proprietary low-conductance material. Large IGU dimensions also reduce the ratio of centre-glass (highest resistance) to frame (lowest resistance). The North House IGUs were the largest dimension of this product yet to be manufactured and are the first units manufactured by the producer to use this semi-insulating spacer.⁵

The wood curtainwall style frame system was faced in quarter-sawn douglas fir with a built-up poplar core. The sill and head use a mechanically fastened fibreglass pressure plate to fix the top and bottom edges of the IGU, with compressive foam gaskets at 80% compression to provide a vapour and air seal without permanent sealants. The vertical joints emulated a 2-sided Structural

Silicon Glazing (SSG) façade with a custom milled nylon ‘T’ and rubber snap-in cap. Overall, the glazing and frame system achieve an insulation value of R8, approximately 4 times more insulating than a typical aluminium curtain wall.

2.2.5 Phase Change Materials

Solar heat gained throughout the day is not only used to passively heat the house during that time but can be stored for use throughout the night. A salt hydrate Phase Change Material⁶ (PCM) is embedded in the floor assembly, directly underneath the engineered hardwood flooring, where it absorbs thermal energy from the sunlight falling directly on the floor during the day while the exterior shades are open or in heat gain mode.

PCMs perform similarly to thermal mass, but have many advantages over traditional thermal mass materials such as concrete or masonry. PCMs are light, flexible and compact, with a greater capacity for heat storage, and a specifiable phase change temperature. They operate on the principle of latent heat, that is, when matter changes phase between solid and liquid it absorbs and releases a great deal of energy from its environment, yet it does not change in temperature. The phase change temperature (freeze/thaw point) of these materials can be specified based on desired thermal comfort set-points. This means that PCMs will not absorb any heat from the air until it has reached the desired temperature range, thus only excess heat will be stored. For passive solar buildings, the desired phase-change temperature is between 20-24°C. The large heat storage capacity and specifiable temperature of the PCM helps to reduce both *total* heating and cooling loads, by storing heat when there is an excess and releasing it when there is a deficit, as well as *peak* heating and cooling loads by mitigating the daily variations in interior temperatures. In winter, this extends the usefulness of daytime heat gain to meet nighttime needs. In summer, this reduces the peak cooling load by storing excess heat during the day and releasing it at night when it can be ventilated away by cool night air.

The PCM selected for application in the North House is a proprietary salt-hydrate solution encapsulated in 15 mm thick polypropylene panels. This particular PCM is engineered to melt at 24°C (76°F) and solidify at 22°C (72°F). A total of 62.1 m² of PCM panels were installed under the finished floor. With a latent heat capacity of 158 kJ/kg, the panels have an approximate heat storage capacity of 62.6 kWh.⁷ Because the PCM is not



Figure 2.22: Salt Hydrate Phase Change Materials (Delta-Cool 24) are laid over the sub-floor, alternating with plywood battons supporting the engineered maple hardwood floor.

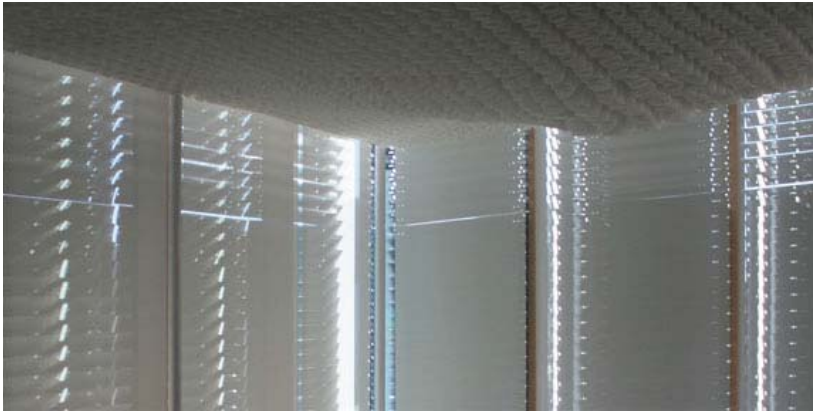

Figure 2.23: Detail of an interior corner of the North House living space with exterior shades closed and interior blinds extended.



Figure 2.24: Detail of the suspended fabric ceiling panels

directly exposed to the interior space, the thickness and conductivity of the floor finish was important to consider. It is estimated that the floor finish will create approximately a 15 minute delay in the absorption and release of heat into the space. The PCM will contribute significantly to the overall energy performance of the home, ESP-r simulations predict the overall space conditioning load of the home is reduced from approximately 2800 kWh/yr to less than 2000kWh/yr through the addition of PCM.

2.2.6 Interior Layers: Roller Blinds and Ceiling Panels

With such highly glazed façades, the control of sunlight and privacy is critical to the comfort of the home. The DReSS includes interior motorized roller blinds to diffuse glare as well as to screen the interior activity from the exterior. The roller blinds are controlled by the user through the ALIS, and can be addressed either individually or grouped by façade. As these blinds are on the interior they have little impact on admission of solar heat gain and therefore can be configured by the inhabitant with no compromise to the overall energy performance of the house. With both the exterior shades and interior blinds working in concert, daylight and view can be shaped to suit any activity or any inhabitant preference.

The suspended translucent fabric ceiling softens the visual and acoustic properties of the space. Parametrically modeled using Rhino 3d and the Paneling Tools plugin, the ceiling is a three-dimensional surface of varying thickness and opacity that moderates the LED downlights, and works with the clerestory tilt-zone of the exterior shades to distribute and diffuse daylight into the living space. It consists of over 5000 unique cells which vary in size and depth to respond formally to the programmatic areas below - swooping down over the dining table to act like a chandelier, receding over the seating area, and helping to hide the ceiling mounted retractable bed when it is retracted against the ceiling. This suspended ceiling also serves to mask the surface mounted electrical and control hardware, and is panelized for easy assembly, disassembly, and access to hardware above.

2.3 INTEGRATED CONTROL STRATEGY

2.3.1 Integrated Active and Passive Thermal Management

The exterior shades and HVAC systems are used for passive and active thermal management respectively, and are co-ordinated through the Central Home Automation Server (CHAS will be explained in detail in Part 3) to ensure the most effective and energy efficient management of thermal comfort in the home. Throughout most of the year the heating and cooling needs can be met by the exterior shades and passive assembly, and as this is the more energy efficient strategy, the CHAS will prioritize this method of thermal management whenever possible, reserving the HVAC system as a backup. This integrated approach offers significant savings in operational energy as well as capital costs, since the majority of the HVAC equipment can be significantly downsized and in some cases completely eliminated. For example, perimeter heaters were eliminated in spite of the large glazed area since the occupant will be thermally comfortable due to the relatively warm interior glass temperatures of these high-performance units.

The CHAS monitors the user determined interior temperature set-point (T_s), the interior temperature (T_i), and the incoming level of solar radiation. Based on these parameters it decides whether to allow or reject passive solar heat into the home or to cool or heat the home actively by engaging the HVAC system. When co-ordinating the interactions of the exterior shades with the HVAC system, the CHAS employs hysteresis, which is an intentional lag between input and output, to ensure that they are not operating at cross purposes and to avoid unnecessary cycling between the two. For example, if the exterior shades were deployed in ‘solar block’ mode and a cloud rolled by and reduced the amount of incoming solar radiation, the exterior shades would not be readjusted until the interior temperature of the house had changed enough that it required solar heat gain to raise the interior air temperature. This strategy ensures that frequent and short-term events such as rolling clouds will not cause the exterior blinds to change states frequently and use excessive energy.

Figure 2.25:
Exterior Shade and HVAC State Diagrams

T_s : User Determined Interior Temperature Setpoint
 T_i : Interior Temperature
 X : Interior Temperature Hysteresis Factor (assume 0.5°C for competition)
 Z : Solar Radiation Hysteresis
 W : Wind Speed Hysteresis
 H : Humidity Hysteresis

Commands
 OPEN: Retract shades
 CLOSED: Deploy shades and rotate shut
 BLOCK: Deploy shades and position perpendicular to sun's rays
 GAIN: Deploy shades and position parallel to the sun's rays

HEAT: Engage mechanical heating
 COOL: Engage mechanical cooling
 +HEAT: Engage heating regardless of cool state

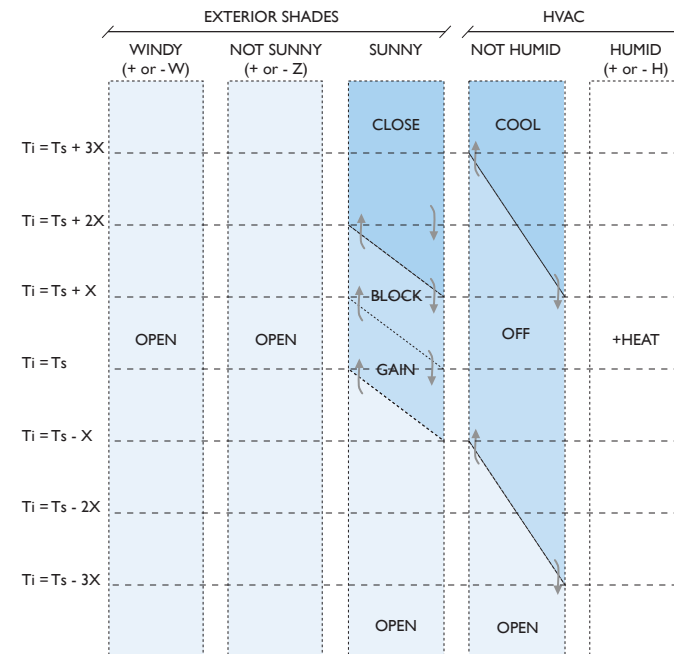

Flow through the state transitions diagrams is up the left and down the right. Diagonal Lines may not be crossed.

Automated and Occupant driven Control of the Mechanical System (Figure 2.26)

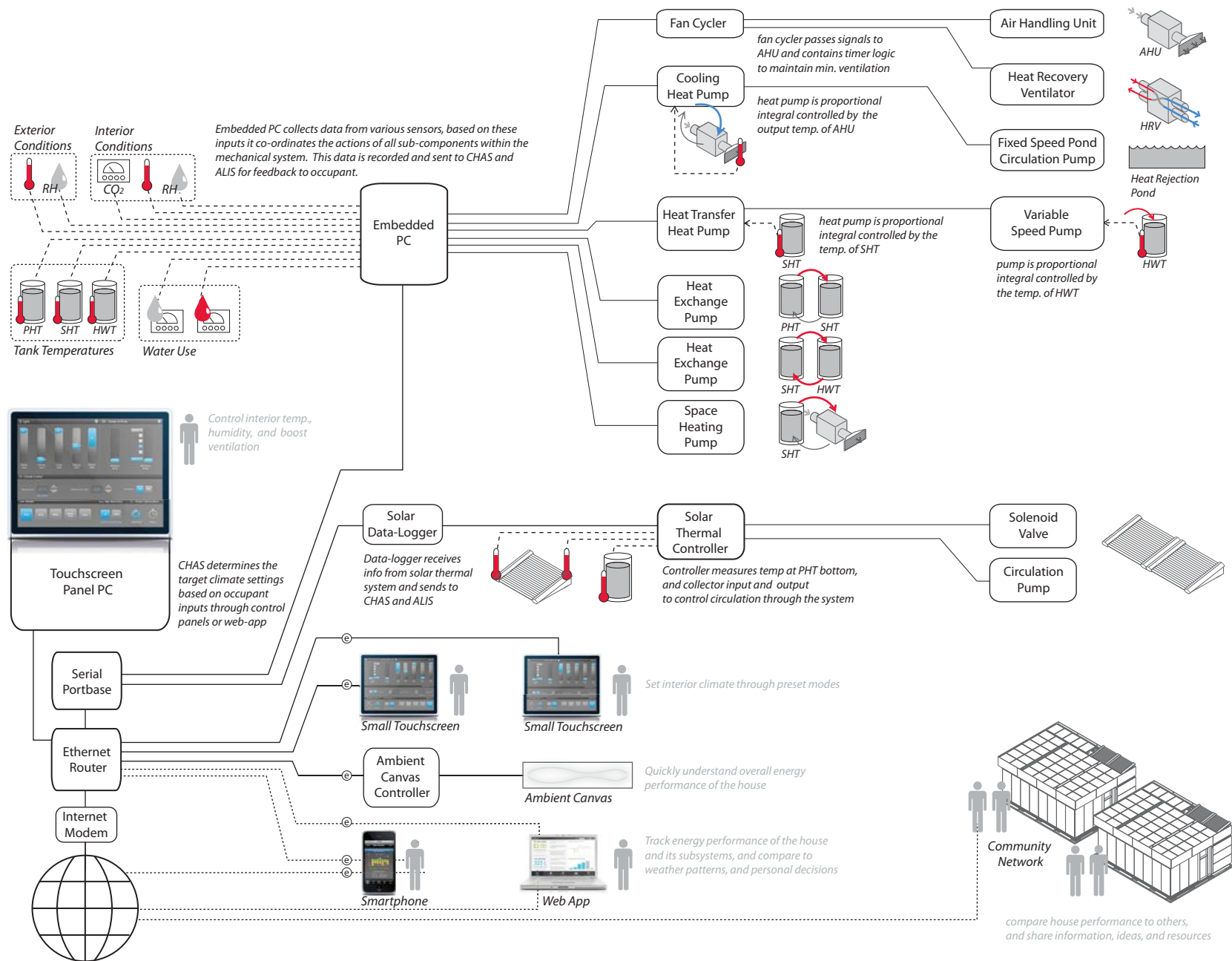

2.3.2 HVAC and Domestic Hot Water Operation and Control

The mechanical system in North House has been designed with the goal of collecting enough solar energy to cover the majority of the domestic hot water and space heating demands throughout the year while conserving every last watt of electrical power. Because of the unique way in which the system has been implemented, simulations have shown that over the course of a year, the system can provide an average of 65% of the required hot water for space heating and domestic uses with collected solar thermal energy alone.

Solar thermal energy is captured through the use of two arrays of evacuated-tube solar-thermal collectors⁸ installed on the roof. Evacuated-tube collectors are known to outperform flat-plate collectors in the colder climates found in many Canadian cities. In order to maintain the aesthetic profile of the house, state-of-the-art ‘direct flow’ collectors are used, which do not rely on the heat pipe effect and thus have the unique ability to be installed horizontally. By orienting the evacuated tubes in the east-west axis, however, it is still possible to rotate each individual tube to an angle of up to 20° to the south without self-shading, further increasing their collection efficiency. A heat dissipator system⁹ is integrated into the solar thermal loop in order to prevent overheated fluid from entering the pre-heat tank and to prevent the collectors from getting dangerously hot. Fluid leaving the collectors is directed to the heat dissipators via a three-way solenoid valve whenever its temperature exceeds 80°C (176°F).

In order to make the most of the collected solar energy, North House is outfitted with a customized and highly-efficient three-tank system, incorporating two advanced variable-capacity heat pumps¹⁰. Each tank is designed to serve a certain purpose: a large preheat tank¹¹ whose temperature floats between -10°C and 80°C (14-176°F) stores collected solar thermal energy; a space heating tank¹² kept at a minimum of 30°C (86°F) supplies hydronic space heating; and a domestic hot water tank¹³ kept at about 50-55°C (122-131°F) provides hot water for the occupants’ daily needs. The tank temperatures and sizes have been chosen in order to ensure that all space heating and domestic hot water demands can be met with ease.

Collected solar energy is delivered to the preheat tank and distributed to the rest of the system as efficiently as possible given the current tank temperatures and heat demands. If there is sufficient solar energy to bring the preheat tank to the required domestic hot water temperature, heat is simply distributed to the other tanks via heat exchanger coils immersed in the tanks and small, high-

Operation of the mechanical system in a winter condition when there is demand for domestic hot water and space heating (Figure 2.27)

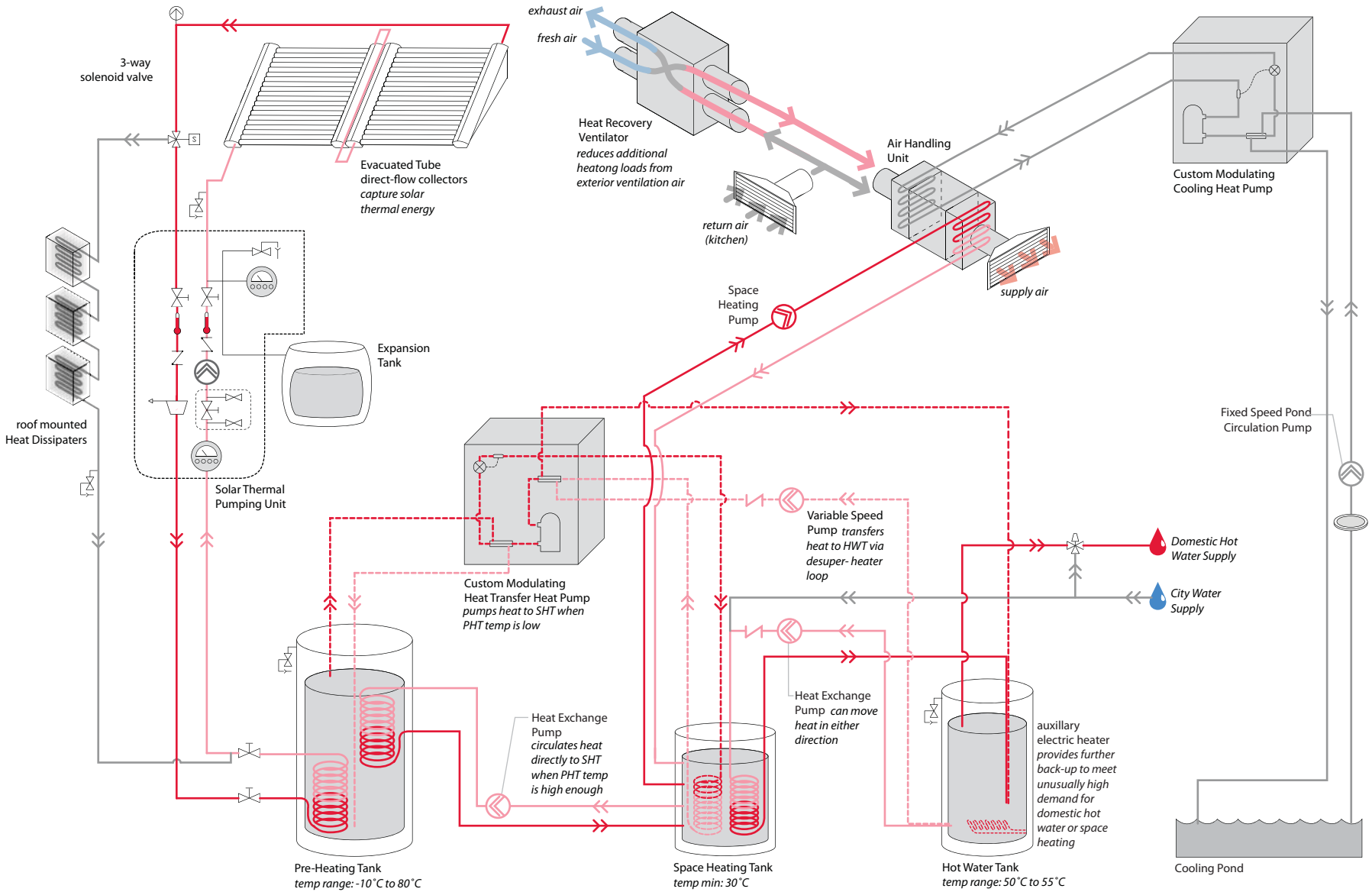

efficiency circulator pumps. When this is not the condition, heat is delivered as required by a custom heat pump.

North House’s heating system strives to outperform a typical gas-fired or electrical resistance system through the use of an advanced heat pump unit. In order to overcome the unique challenge of efficiently pumping heat from widely varying low-side temperatures, the heat pump consists of a digital scroll compressor¹⁴ and an accurate controller¹⁵. This allows the heat pump capacity to modulate down to 10% with negligible loss in efficiency in order to achieve the best possible performance under a wide range of conditions. Heat is transferred to and from the heat pump evaporator and condenser via heat exchanger¹⁶ loops with fluid circulated by precisely controlled variable-speed pumps¹⁷, which constantly adjust to deliver only the necessary amount of heat, and minimize required pumping energy. A desuperheater¹⁸ loop delivers the higher temperature latent heat from the superheated refrigerant directly to the domestic hot water tank, minimizing heat transfer efficiency losses. To further guarantee that heating demands will be constantly met, two auxiliary electric heaters are located in the domestic hot water tank to add heat as necessary, though we expect that they will rarely be needed.

Space heat is distributed to the living space via a hydronic coil located in the air handler.¹⁹ Space cooling demands are met through a second custom modulating heat pump which adjusts to draw the appropriate amount of heat from the air via an evaporator coil in the air handler. This heat is dumped to a cooling pond²⁰ located in the shaded area under the deck, which naturally loses its heat through a combination of evaporative cooling, convective losses to the surrounding air, and conductive losses to the earth. The pond was used during competition, but will be replaced by a geothermal ground loop or borehole storage system, once the house is installed in its permanent location. Combining the near-ambient temperature heat dump with the gain in heat transfer effectiveness achieved when using such a water-based system, the heat pump is expected to greatly outperform a typical air-source heat pump, achieving a cooling Coefficient of Performance²¹ of between 4 and 5. This means that for every 1 unit of energy required to operate the heat pump, 4 to 5 units of energy would be removed from the air.

In order to reduce the additional heating and cooling loads introduced when required ventilation takes place, incoming fresh air passes through a heat recovery ventilator²². The air handler and heat recovery ventilator

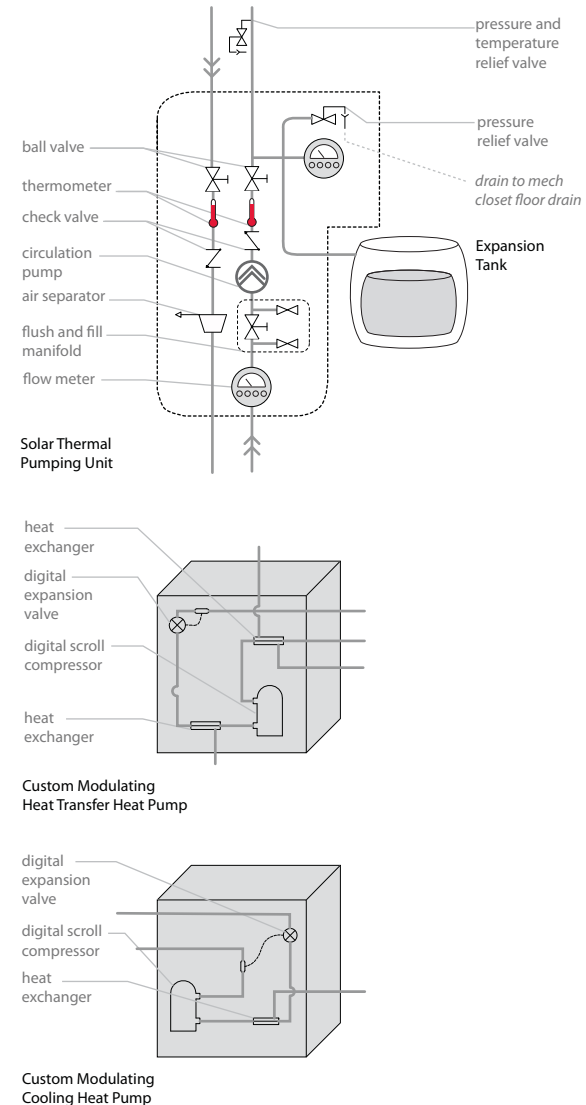
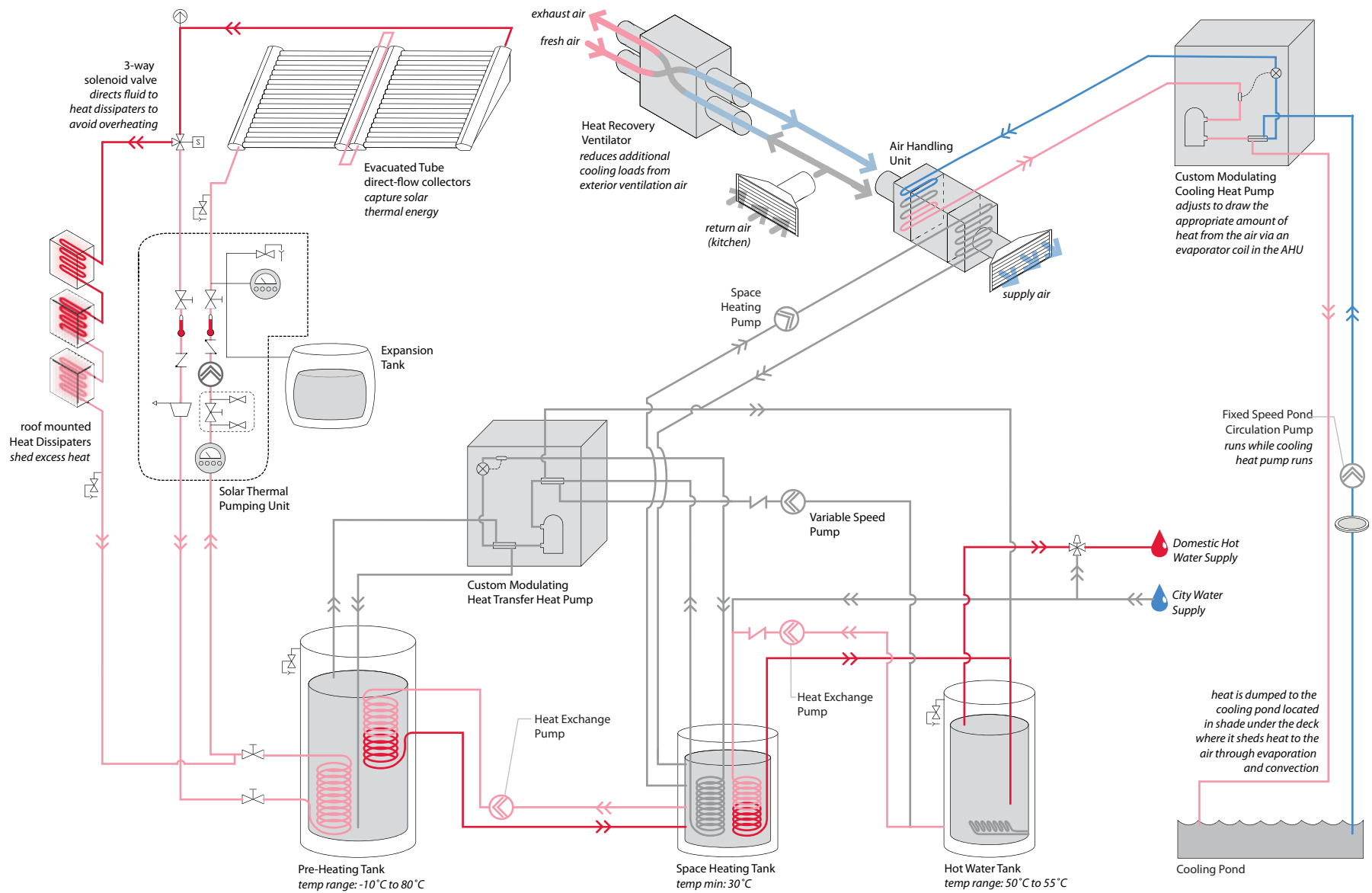

Figure 2.28: Custom Component details of the mechanical system

Operation of the mechanical system in a summer condition when there is demand for domestic hot water and space cooling (Figure 2.29)



are controlled by an embedded PC²³, part of the CHAS, which adjusts operation based on frequently measured temperature, relative humidity, and carbon dioxide content. The CHAS operates the HVAC system based on an algorithm which takes into account previous operation states in what is known as a hysteresis. The hysteresis eliminates any frequent cycling of the mechanical system due to minor changes in internal air temperature and relative humidity over predefined set points. This allows the system to have multiple states within the same temperature or humidity range depending on that status of the previous state. Based on the temperature and relative humidity set points defined by the occupant, the CHAS automatically adjusts the mechanical system to deliver the desired conditions for thermal comfort.

2.3.3 Exterior Shade Operations and Control

The automated control strategy for the exterior shades balances the management of solar gain with concerns for daylighting and equipment safety in windy conditions. The inhabitant can also determine the configuration of the shades at any time, unless a wind safety override is in effect.

Dynamic Shade Control for Solar Gain

There is one roof-mounted omni-directional photosensor which is used to determine if the sun intensity is sufficient to impact heating in the house. The sun sensor continuously reports a single Boolean value *sunny* or *not sunny* measured against a configurable threshold nominally set to 100 lux. If the sun sensor reads *not-sunny* continuously for 30 minutes the blinds will retract, entering *No Sun* mode. When the threshold has been exceeded and the sensor again reads *sunny*, the mode will immediately change to the required thermal management mode.

The exterior shades can be deployed in four thermal management modes depending on thermal needs and solar resource availability. If the sun sensor reads *sunny*, the CHAS will determine the location of the sun in the sky based on longitude and latitude, time of day, and time of year. From this it will decide which facades are receiving direct sunlight and calculate the incident angle of the sun on the facade. Only those facades receiving direct sunlight will be activated in the thermal management modes, and the remaining facades will be configured to the open position by default.

The four thermal management modes are described below:

Open: The shades are fully retracted, allowing full solar penetration and maximum solar gain.

Closed: The shades are fully extended and the slats are positioned vertically to block out all solar radiation.

Solar Gain: The shades are fully extended and the slats are oriented parallel to the incident angle of the sun to admit the greatest amount of direct solar radiation, which is cast on the floor where it is absorbed by PCM. As the sun position changes, the angle is continuously adjusted to maintain a parallel position. This approach also allows the shades to quickly switch to solar block mode when needed, with only a rotational adjustment.

Solar Block: The shades are fully extended and the slats are oriented perpendicular to the incident angle of the sun to block the greatest amount of light. As the sun position changes, the angle is continuously adjusted to maintain a perpendicular position. As stated above, this approach allows a quick transition to solar gain mode when necessary.

Throughout much of the year, especially the mild and cold seasons, the exterior blinds will cycle between *Solar Gain* and *Solar Block* modes in order to maintain a consistent interior temperature. This finely articulated control of passive solar gain is capable of providing heating and mitigating cooling needs for most of the year, but when necessary the HVAC system can assist. When the difference between the interior temperature set-point and the measured interior temperature exceeds a nominal value, the HVAC system will be activated. This value can be varied based on the inhabitant's ideal balance between thermal comfort and energy efficiency. The larger the value: the larger the acceptable temperature range before triggering the mechanical system, and thus the more energy efficient the overall system. Conversely, the smaller the value: the smaller the acceptable temperature range, and thus the more consistent the interior temperature.

Shade Control for Daylighting

Although the exterior shades are programmed to prioritize thermal management, the control strategy also takes daylighting into account. When the shades are operating in thermal management modes, any façade not receiving direct sunlight will remain retracted to allow useful indirect light into the home. Likewise, if the sun sensor reads *not-sunny*, all shades will retract

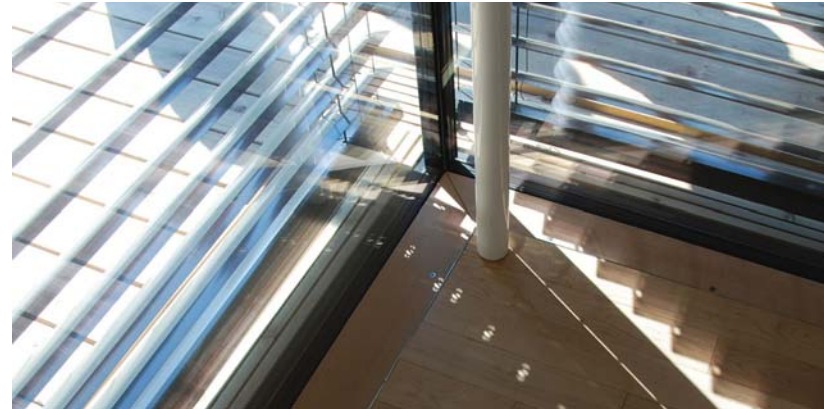

Figure 2.31: Detail of a lower interior corner of the North House living space with exterior shades in Solar Block mode and interior blinds retracted.



Figure 2.32: Lighting condition in Kitchen when exterior shades on east facade are in solar block mode with clerestory tilt zone open.

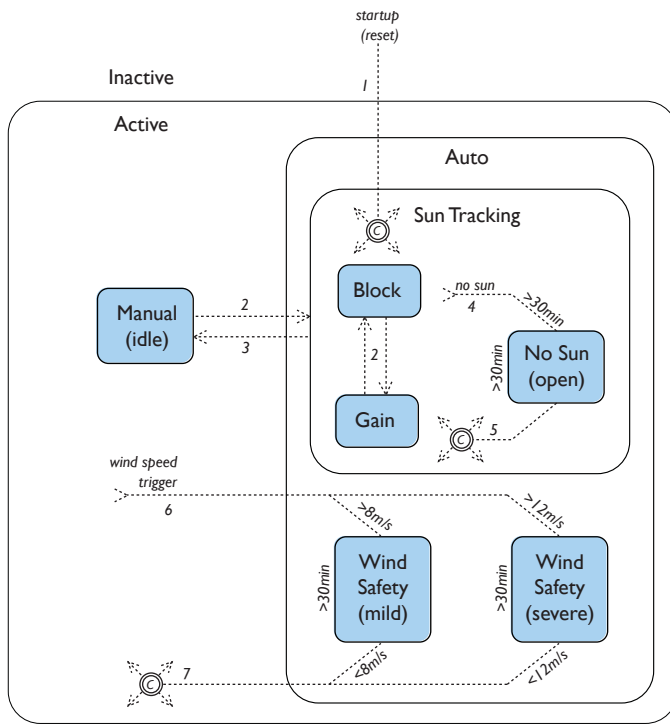

Figure 2.33: Exterior Shades Control States Diagram

Control Modes State Diagram

Notes:

The transition from a superstate (e.g. the transition from the active superstate to the safety mode) is a shorthand for transitions from any child substate (at any nested level) of the superstate.

The circle c denotes a conditional transition. When there are no explicit “to” transitions specified the transition can be to any state, conditionally. The condition definition is specified below.

allowing all façades to collect diffuse sunlight under cloudy and overcast conditions.

The configuration of the shades in both solar tracking modes, *solar block* and *solar gain*, has the added benefit of reducing unwanted glare in both cases. In block mode, the slats are positioned perpendicular to the sun and direct solar radiation is blocked, which reduces both solar gain and glare. Counterintuitively, perhaps, glare is also significantly reduced under gain mode, as the direct sunlight is channelled directly to the floor, while diffuse sunlight is blocked.

The dual-zone operability of the exterior shades allows further options for daylight control. At times when the exterior shades are operating in solar block mode, the inhabitant can choose to orient the upper zone of the shades horizontally to act as a light shelf, admitting daylight with little compromise to thermal performance.

Shade Control for Wind Safety

A roof-mounted wind sensor continuously monitors wind speeds to determine if conditions are safe for the operation of the exterior shades. If the unsafe conditions are detected, the exterior shades will assume one of two wind safety overrides. Safety overrides differ from all other modes in that the occupant can not override the shade position with their own preference until the safety mode is de-activated.

Severe Wind Override: When a wind speed reading exceeds 12 m/s, all shades will immediately retract to prevent damage. When the wind speed falls below 12 m/s and does not exceed that speed continuously for a period of 30 minutes, the shades will resume their expected state.

Mild Wind Override: If the blind is not already in a severe wind override, and the wind speed exceeds 8 m/s all shades that are extended will assume a horizontal position. Once wind speed falls and remains below 8 m/s continuously for a period of 15 minutes, the shades will resume their expected state.

The expected state after either wind override is the state in which it would otherwise have been if it were not in the safety override. Depending on the

Control Modes and States Definitions

State	Description
Active	SC2 controller is booted and accepting commands and capable of controlling blind positions
Manual	The SC2 controller is not controlling the blind, but sits idle waiting for commands via the serial interface
Auto	The SC2 is responsible for blind movements
Sun Track	The SC2 controller is tracking the sun position, which may or may not be used depending on the blind orientation, time-of-day and availability of sunshine (e.g. not cloudy conditions)
Gain	The blinds track the sun, blades parallel to the sun's rays, admitting sunshine, with the goal of increasing the internal temperature
Block	The blinds track the sun, blades perpendicular to the sun's rays, with the goal of preventing incident sunshine from increasing the internal temperature
No Sun	Based on the time of day, location of the blind, and possibly the sun sensor as well, there is no sun on this blind, the blind is fully retracted
Safety	After a wind speed trip, the blinds retract until the wind speed has been below the trip speed for some defined period of time

Control Mode Transitions

#	Trigger	Description
1	startup	On startup or midnight reset, the blinds enter the Sun Track mode. Depending on the blind location, time-of-day and/or sun sensor reading they may enter No Sun mode. If the blind does not need to enter No Sun mode, the Sun Track Block or Sun Track Gain mode will persist from the before the power cycle or reset occurred. The first one-time initialization mode is by default Sun Track Block.
2	Modbus command	The SC2 controller is instructed to enter Sun Track Block or Sun Track Gain mode. If there has been insufficient sunlight for 30 minutes, as determined by the sun sensor, the controller will bypass the selected mode going directly to No Sun.
3	Modbus command	Any manual motion command (extension or rotation) takes the controller out of Auto mode and puts it into Manual mode where it waits (idle) for a further command until the next auto-tracking command is received.
4	Sun Sensor or time-of-day	Depending on the time of day or when light level has been below the threshold for more than 30 minutes, the blinds will enter No Sun mode and the blinds will retract but save the selected state for a possible later transition back when conditions change.
5	Sun Sensor or time-of-day	The blinds enter Sun Track Block or Sun Track Gain if based on the time-of-day sun could be incident on this blind and the sun sensor is showing sunny conditions. Which mode is determined by the last Modbus command that was received.
6	Wind Speed	From any active state the wind speed has exceeded the safety criterion and the blinds move to a safer angle or retract (depending on the detected speed) until safe to return to normal operation
7	timeout	Depending on the time of day or when the wind speed has been below the safety criterion for the specified wait time, the controller conditionally transitions to a state depending on what has happened while in safety mode. While in safety mode, the controller tracks the mode that would be in effect if not in safety mode and when the timeout occurs, it transitions to that mode. This means that Modbus commands received and the sun sensor effect the mode which is entered after the timeout. Time of day impacts blind extension based on whether sun is expected to be incident on the facade at that time.

Control Modes

At any moment, the blinds will be in one and only one mode. This mode may be part of one or more greater super states. Changes in mode (and superstates) will only occur in the manner described in this section. This will ensure that the central house controller always knows the state of each Embedia SC2 blind controller.

REACTIVE CONTROLS

inhabitant control

defaults and overrides

 open

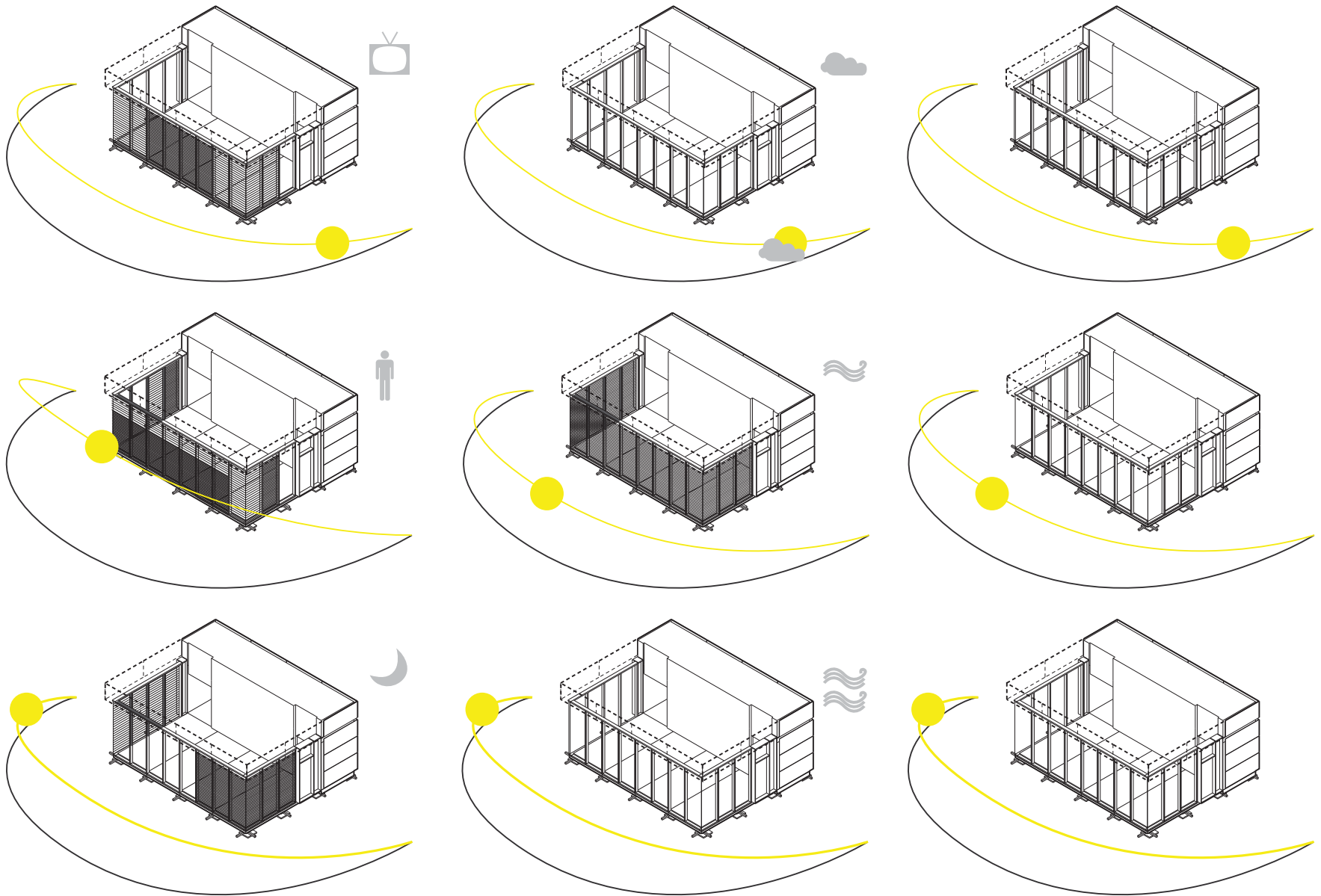

Conditions and Configurations of the Exterior Shades (Figure 2.34)

AUTOMATED THERMAL MAINAGEMENT

 solar gain

 solar block

 close

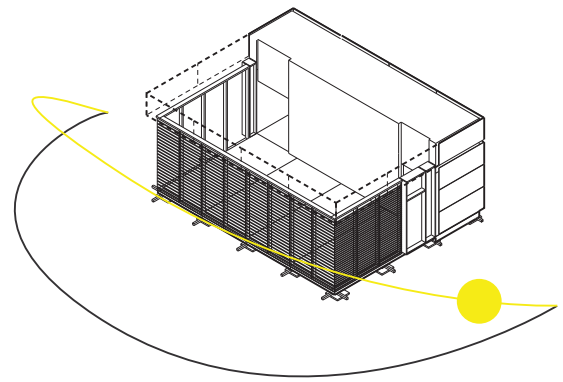
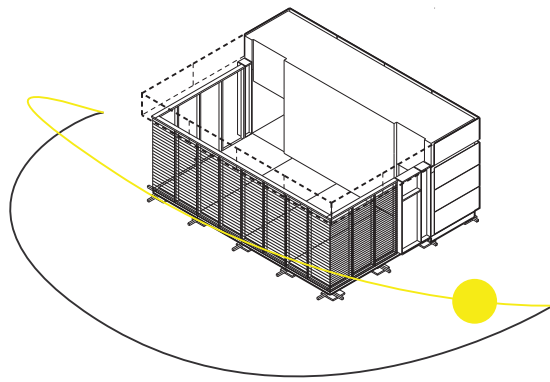
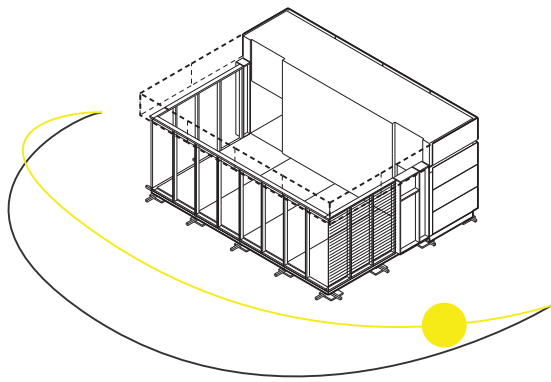

7:00am

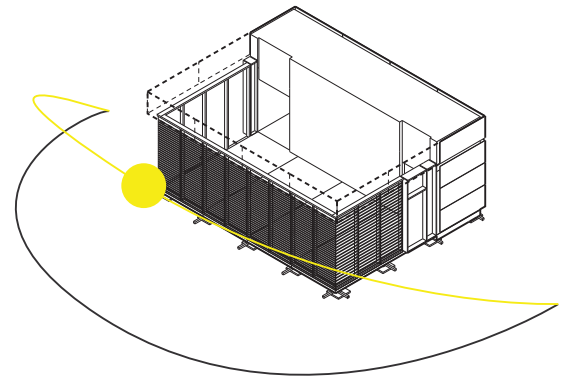
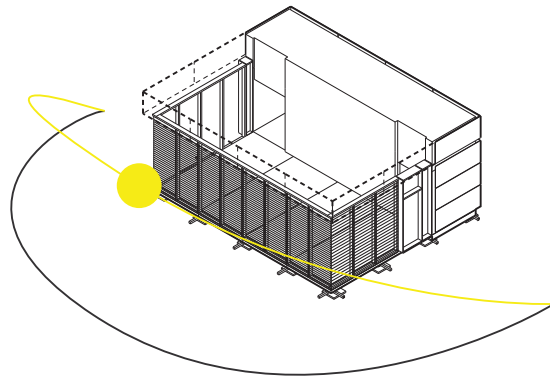
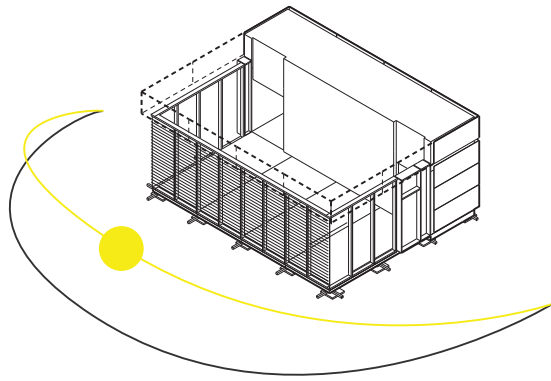

12:00pm

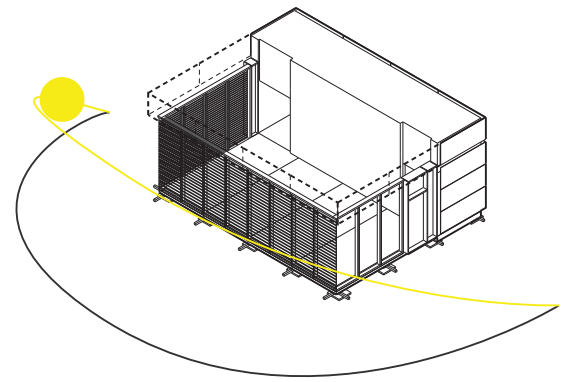
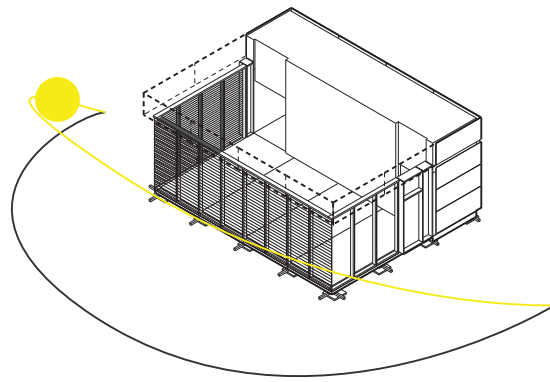
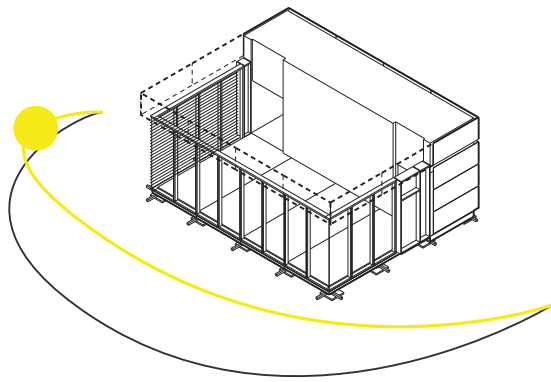

7:00pm

time-of-day, sun intensity and occupant inputs, this may be different from the state that the blind was in prior to the safety override occurring.

2.4 NORTH HOUSE ENERGY BALANCE

The overall predicted energy balance of the North House is based on results from various energy simulation tools used to evaluate the performance of different systems and components. WUFI, WINDOW5, VISION5, and THERM were used to simulate the building envelope components. TRNSYS was used to simulate PV power generation and HVAC performance. ESP-r and EnergyPlus were used to simulate the interior heating and cooling loads and to evaluate the effectiveness of the DReSS.

The ESP-r building energy simulation was based on the following assumptions:²⁴

- The climate information is from a Toronto CWEC file containing hourly weather observations representing an artificial one-year period.
- Heating set-points is 21°C and cooling set-point is 25°C. Although the Solar Decathlon Rules required the house to be maintained between 22.2°C (72°F) and 24.4°C (76°F) during the competition, the set-points used in the model reflect a more typical condition.
- The house is assumed to be occupied by two people at all times. This reflects an assumption based on the competition design brief specifying the home as a live-work unit. In reality, should the house be occupied less frequently, overall energy consumption would decrease.
- The ventilation rate is set according to ASHRAE 62.2 which requires 7.5 cfm/person and 0.01 cfm/ft² of floor area for a total of 21.7 cfm or 0.20 ACH

The results of the ESP-r model, show the drastic reductions in space conditioning loads attributed to the effect of the DReSS element such as high performance glazing, dynamic shading, and PCM. With the space conditioning loads dramatically decreased to less than 2000 kWh/yr (32.7 kWh/yr/m²), the remaining heating and cooling loads along with other end-uses can be easily met with Building Integrated Photovoltaic power generation and Solar Thermal collection. Accounting for operational efficiencies, auxiliary equipment of the HVAC system, appliances, and plug loads the total annual energy consumption of the

home is estimated at 4400 kWh/yr or about 70 kWh/yr/m² of conditioned space. The breakdown of estimated annual energy end-use and predicted energy production from the photovoltaic and solar thermal arrays suggest the North House will produce twice as much energy as it and its inhabitants will consume on an annual basis.

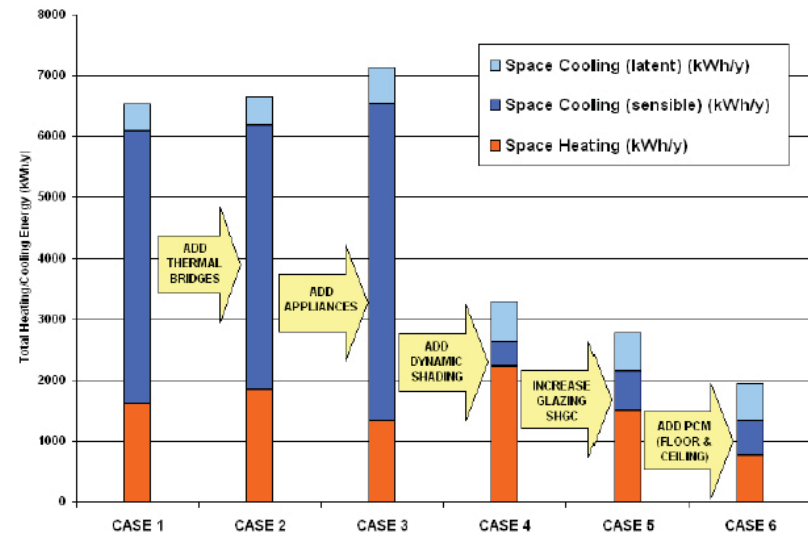

Figure 2.35: Effect of DReSS on predicted annual space conditioning loads

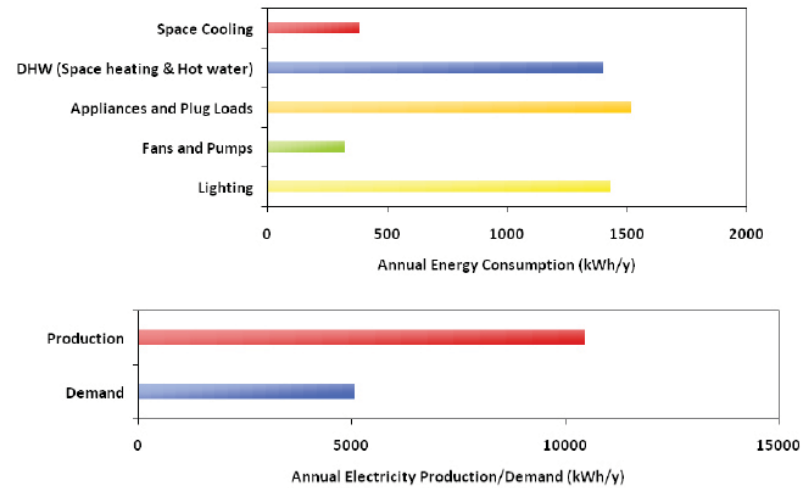

Figure 2.36: Predicted annual energy consumption by end-use, and Comparison of Production to Demand



2.5 ARCHITECTURAL EXPRESSION AND INHABITANT EXPERIENCE

“A window without shutters is like an eye without eyelids” – Eileen Gray

While the DReSS achieves high-performance in terms of energy efficiency, passive thermal management, and daylighting, it also addresses issues that are relevant to the architectural project on a much broader level. Questions regarding the boundary between interior and exterior, issues of privacy and publicity, the manipulation of light, and framing of views all find their locus at the thickened architectural edge. Defining each of these conditions has traditionally been the architect’s privilege, and he or she articulates the relationships permanently through the construction of this edge. In North House, this edge and the definition of each of these conditions remains fluid, allowing the inhabitants to shape their space according to their daily rituals, moods, values, and desires.

That the inhabitants can fully control the admission of light, heat, views, and the transparency, translucency, and opacity of the building envelope at any location, opens up a range of configurations broad enough to allow complete contradiction between available options. The entire house, then, can become a register of the complex economy between interior and exterior environmental conditions, activity within the home, and emotional state of the inhabitant.



Boundary and Connection to Landscape

“one of the basic human requirements is the need to dwell, and one of the central human acts is the act of inhabiting, of connecting ourselves, however temporarily, with a place on the planet, which belongs to us, and to which we belong.” – Junichiro Tanizaki

The compact interior of the North House celebrates the small home with an open-concept floor plan and flexible arrangement of furniture and programme. This small resource efficient enclosure relies on the ability to appropriate exterior space visually and physically, encouraging the inhabitants to extend their living space outdoors as much as possible during good weather. The floor to ceiling glazing maximizes the visual connection to the exterior, and when the shades are retracted, the boundaries of the interior space virtually extend to the limits of the surrounding landscape. One feels that the true walls defining the space are not the glass partitions but the edges of the deck and the thick waving grasses.

With the interior blinds extended, the interior space is cosily defined, with the connection to the landscape present but muted and diffuse. When the exterior shades are closed, the interior space takes on an intimate, inward looking quality. When the exterior shades are deployed, in solar gain or solar block mode, the connection to the landscape is bounded but porous, taking on the character of a semi-screened garden pavilion. As the shades operate to mediate the interior temperature they create a shifting definition of the space, and each time they adjust from block to gain, the inhabitant is made aware of their relationship to the home and to the world beyond.



Private and Public Presence

The open-concept flexible living space creates a highly variable relationship between the private and public realm inside the home. Furniture configurations can redefine the space according to the occupants' current activity. For example, the bed can be retracted up to the ceiling to extend living or dining space, transforming the house into an entirely public realm. Conversely when the bed is deployed, the entire living space takes on the intimate quality of a bedroom. This relationship is equally variable on the building envelope, which can be modelled to suit the public or private nature of the interior and exterior activities. The full gamut of possibilities is available here. The domestic realm of can be explicitly public, with the interior activity on display as overtly as a stage set projecting light and spectacle outward; or it can be intimately guarded with exterior light and view carefully shut out with multiple layers of screens. Any conceivable intermediary condition can also be achieved - blocking views in and out from one direction, framing views in another, and screening them in yet another.

The interior blinds add a second layer of mediation. When the interior blinds are extended, the house becomes a Japanese lantern with veiled illumination of the activities within. The palette of transparency, translucency, and opacity provided by the floor to ceiling glazing, and the fully extensible interior blinds, and adjustable porosity of the exterior shades generates opportunities for a richly varied and highly nuanced relationship between the interior domicile and the exterior public realm.



Manipulation of Light and Views

The manipulation of light is one of the most powerful tools available to an architect. Light is used for way-finding, for emphasizing formal expression, for poeticizing material properties, and for animating space. In the North House, daylight is a dynamic element engaged in a constant duet with the exterior shades, resulting in an interior space that ambiently registers the flow of energy in and around the building. The profusion of daylight and its inherent fluctuations has healthful and stimulating effects on inhabitants especially in the northern climate. The range of activities that occurs within a home over the course of the day may have different daylighting requirements and can be accommodated flexibly, allowing the inhabitant to live with the sun, or perhaps with the shade. For example, the inhabitant may want to flood the room with sunlight for their morning rituals, but they may then want to block glare from a computer screen, or direct sunlight to a particular chair where they sit to read, while maintaining soft dappled light through the rest of the home.

- 1 Bartosz Aleksander Lomanowski, *Implementation of window shading models into dynamic whole-building simulation*, (Waterloo, Ont.: University of Waterloo, 2008)
- 2 Ivan Yun Tong Lee, Christopher Black, and Bartosz Aleksander Lomanowski, *High Performance Facades for Heating and Cooling in Northern Climates*, Anonymous, International High Performance Buildings Conference at Purdue., July 12-15 2010), 3454-3462.
- 3 K. G. Terry Hollands, J. L. Wright, and C. G. Granqvist, "Glazings and Coatings," in *Solar Energy: The State of the Art ISES Position Papers*, ed. Jeffrey Gordon. Anonymous (London, UK: James & James (Science Publishers) Ltd., 2001), 29-107.
- 4 Lee, Black, and Lomanowski, *High Performance Facades for Heating and Cooling in Northern Climates*, 3454-3462.
- 5 *ibid.*
- 6 Delta Cool-24 panels
- 7 "Delta PCM Smart Temperature Management," in Cosella Dorkin Products [database online]. [cited 2010]. Available from <http://www.cosella-dorken.com/bvf-ca-en/products/pcm/index.php>.
- 8 Veissman Vitosol 200-T Direct flow vacuum tube collectors
- 9 Apricus HD-25 Heat Dissipators
- 10 Custom Heat Pump units (2) designed and built for North House by Eco-Options GeoSolar in partnership with EcoLogix Heating Technologies
- 11 Bradford-White Ecostor S-DC-DW2-110R6SW (110 gal) with dual heat exchange coils
- 12 Custom Space Heating Tank (30 gal) designed and built for North House by Eco-Options GeoSolar
- 13 Bradford-White M-2-HE-40S6DS (40 gal) with two 3000W auxiliary electric backup heaters
- 14 Copeland ZPD34k5E-PFV
- 15 Alco Controls EC3-D72
- 16 Packless COAX-2400-J
- 17 Grundfoss UP 14-42F/VS
- 18 Packless CDAX-5030-H
- 19 Ecologix Eco-Pac EP30 with additional 4" deep MERV-13 air filter
- 20 Custom built cooling pond, site built, wood frame exterior with EPDM pond liner
- 21 Coefficient of Performance (COP) of a heat pump is the ratio of the change in heat at the "output" (the heat reservoir of interest) to the supplied work. The COP of heating and cooling are different, as the heat

generated by input work is factored into the COP heating. For example: a heat pump operating at $COP_{heating} 3.5$ provides 3.5 units of heat for each unit of energy consumed (e.g. 1 kWh consumed would provide 3.5 kWh of output heat). The output heat comes from both the heat source and 1 kWh of input energy, so the heat-source is cooled by 2.5 kWh, not 3.5 kWh. A heat pump cooler operating at $COP_{cooling} 2.0$ removes 2 units of heat for each unit of energy consumed (e.g. such an air conditioner consuming 1 kWh would remove heat from a building's air at a rate of 2 kWh).

- 22 Fantech SH704 with washable electrostatic filters
- 23 Beckhoff CX1010-0111
- 24 Lee, Black, and Lomanowski, *High Performance Facades for Heating and Cooling in Northern Climates*, 3454-3462.



...“notwithstanding all the implications of supposedly advanced automation, our experience is that the best intelligence in most buildings lies in the occupants themselves” and that the “challenge for designers and manufacturers is then to support them with appropriate and understandable systems with readily-usable control interfaces, which give relevant and immediate feedback on performance.” In other words, buildings in and of themselves cannot be “intelligent” but can support intelligent patterns of behaviour.

- Raymond Cole and Zosia Brown quoting Cohen et.al.

PART 3

INHABITANT RESPONSIVENESS AND SUSTAINABLE LIFESTYLES The Design and Integration of the Adaptive Living Interface System and the Central Home Automation System

The Adaptive Living Interface System (ALIS) and the Central Home Automation System (CHAS) work together to manage many sophisticated high-performance technologies, allowing them to be appropriately operated in a domestic environment. The CHAS controls the operation of all of the sub-systems in the home: lights, exterior shades, interior blinds, the custom mechanical heating, cooling, ventilation and hot water system, as well as data-acquisition on energy production, and energy and water consumption throughout the home. The ALIS allows the inhabitant to interact with these systems, controlling them and viewing feedback through a variety of interactive media. Together, the ALIS and CHAS move beyond conventional home automation and monitoring to support the inhabitant in living an informed and empowered energy efficient lifestyle, by providing an easy-to-use ubiquitous interface, supporting residential tasks integrated with the user's lifestyle, and providing meaningful performance feedback. In this chapter, I present the North House's ALIS and CHAS, beginning with a review of existing in-home Graphic User Interface Systems, then presenting a characterization of the intended user, the design principles that guided our design development of these systems, and finally an illustrated description of the components and operations of the implemented systems.

3.1 INDUSTRY REVIEW OF IN-HOME GRAPHICAL USER INTERFACE SYSTEMS

Early in the design process, the North House interaction design team conducted an industry review of existing digital Graphical User Interface (GUI) based home automation and monitoring systems. The surveyed systems are either currently available or in the final phase of development. They vary widely in format, media, and level of sophistication, representing a broad cross-section of the industry. The team reviewed five desktop and web-based GUIs, four in-home touch-panel GUIs, three mobile device based GUIs, and six mixed device systems.¹

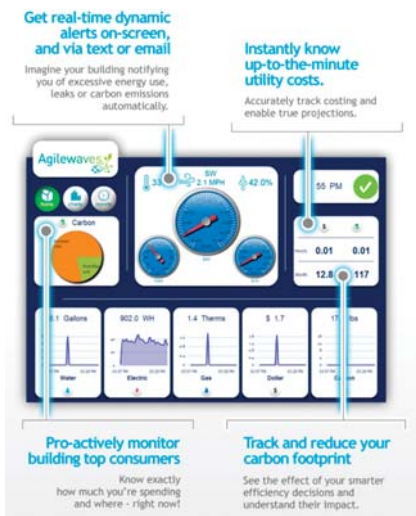

Figure 3.1: Screenshot of Agile Waves, a sophisticated home monitoring and Control GUI system



Figure 3.2: Owl Ecosavers Energy Meter displays power consumption, cost, and operating time for a single outlet on a small LCD screen.

Though there were a few instances where a system prioritized both resource monitoring and home control,^{2 3} many of these systems tend to be positioned either as a home automation system or as a home resource monitoring system. The home automation systems tend to be marketed to residents of large luxury homes, and control the high-end of a suite of relatively conventional technologies, such as lights, thermostat, blinds, home entertainment, security systems, and irrigation.^{4 5 6 7} When these control systems do integrate resource monitoring, it is often treated as a peripheral rather than central feature.^{8 9}

Home resource monitoring systems vary widely in sophistication, legibility and functionality, from simple LCD screens displaying power draw at a single outlet,¹⁰ to elaborate visualization of the resource use by area within the home, and by historical trend.^{11 12} Many of these monitoring systems made use of a variety of measurement units that were meaningful to the inhabitant, such as dollars, or tons of CO₂. One even went as far as quantifying water consumption by number of bathtubs or water coolers.¹³ Few of the monitoring systems that we surveyed made explicit use of social networking or community groups as a source of motivation, information, or support, though some did provide data comparisons with neighbours or regional averages.^{14 15 16} An interesting application of the community network component was a system designed for implementation in multi-unit apartment buildings in Sweden, where apartment dwellers could make bookings for shared amenities, communicate with fellow residents and building management, view local public transit times, as well as compare their energy use to other residents.¹⁷

Few home resource monitoring systems actually included monitoring of energy production technologies; however, many renewable energy products also include an accompanying monitoring system, which can be integrated with common protocols.

The navigational structure of the software varied widely between systems. Some provided a great deal of information or options on a single page, making it easy for the occupant to access each function without navigating through many pages. As a trade off, the programs with the most comprehensive and legible visualizations of the information often required a deeper navigational structure. For these systems, a comprehensive introductory page was key to guiding the user to the appropriate information.

Based on the unusual suite of custom high-performance technologies employed in North House, it was required that a new control and monitoring system be developed. This review, however, enabled us to see the results of similar ambitions and to evaluate the relative merits of the range of strategies employed.

3.2 UNDERSTANDING THE INHABITANT

Understanding the user of any system, especially a home control and monitoring system, is central to creating an appropriate design for them. We characterized our users along several complimentary dimensions; *engagement*, how actively involved they are or want to be in the process of how the systems of the house work; *commitment*, how much are they prepared to commit in terms of time and learning curve; *goals and motivations*, are they most motivated by financial, ecological, social, or pragmatic incentives; and *technological aptitude and inclination*, are they naturally adept at using sophisticated technology.¹⁸

We intend the ALIS and CHAS to be accessible to a broad segment of the Canadian population and recognize that each resident will have a different set of priorities and constraints, and many will be unable or unwilling to make major lifestyle changes or commit large amounts of time and effort to realizing a more sustainable lifestyle. With this in mind, we defined our intended users as an intentionally varied group and therefore provided control and monitoring features that would accommodate users with a low level of engagement, low level of commitment, varied motivations, and low technical aptitude. In spite of this, we made every attempt to reward a high level of engagement and commitment, while supporting the user in broadening their motivations and enhancing their technical knowledge.

3.3 DESIGN PRINCIPLES

The ALIS and CHAS co-ordinate the complex interaction of many different systems. In order to best support the our intended user in operating these systems easily and intelligently, we designed with these principles: provide an appropriate balance between automation and user control; support tasks that suite the inhabitant's needs; provide easy access and navigation to information and control; providing meaningful feedback to the inhabitant; integrate technology with the inhabitant's lifestyle; and provide personal and social incentives to conserve energy and other resources.¹⁹

Appropriate Balance of Control

The ultimate goal of the ALIS and CHAS is to enable an average residential inhabitant to easily and intelligently operate a set of sophisticated and unfamiliar technologies in their home. In order to achieve this, it is critical to find the right balance between automated and user-driven control. The system must be able to manage itself efficiently while always offering the inhabitant the power to configure the house as they desire. Raymond Cole's concept of occupant intelligence suggests that occupants are more satisfied with their thermal comfort conditions if they perceive that they have control over their thermal comfort conditions.²⁰ It is just as important, however, to make it easy for the occupant to resume automatic control as it is to allow them to override it; the inhabitant may want to temporarily override a setting without taking on the burden of continued manual control. This thinking influenced features such as the 'optimize' command, which resumes automatic control of all systems in their most efficient settings either immediately or after a user determined interval of time. Though the exact definition of this 'optimized' state is as yet undetermined, it currently includes resetting all exterior shades to automated control and will potentially include other resets. One possible application for 'optimizing' the HVAC control is that this command could widen the threshold temperatures that activate mechanical heating or cooling. This would result in an interior temperature that follows the cycles of the exterior temperature, which Brager and de Dear demonstrated to be preferable to occupants of naturally ventilated buildings.²¹

Support the Right Tasks

Closely linked to finding an appropriate balance of control is the principle of supporting the right tasks. Rather than think of the tasks the inhabitant performs in terms of the specific house technology, we need to capture what they want to do. For example, the inhabitant doesn't want to turn off all the

lights and reduce heat when away; rather, she wants to conserve as much energy as possible while making sure the house will be comfortable when she returns. Identifying tasks with respect to desired outcome as much as possible enables us to define modes and task sequences that reduce the user's cognitive overhead and time to execute. Preparing the house for a period of absence, for example, may better be modeled as a mode with configurable settings rather than as a set of individual steps.

Easy Access and Navigation to Information and Control

Feedback and access to building control should be accessible wherever and whenever the inhabitant desires it. Participants in study by Chetty et al. expressed a preference for a centralized location for control and monitoring of all systems.²² The ALIS control points are conveniently located within the home and are always remotely accessible. Extending the control and monitoring features to the web and smartphone means that the inhabitant is always connected to their home, aware of its operations, and able to operate it as necessary.

Beyond making ALIS devices physically convenient and ubiquitously connected, inhabitants must also be able to intuitively operate the control elements and easily navigate to their desired information or setting. Chetty found that many people do not want to take the time to learn how to operate a programmable thermostat. Given that this system is substantially more complex than a programmable thermostat, it is crucial that our system presents the minimum cognitive overhead to the user. They should never feel that they would like to learn how to operate it but don't have time to invest in it.

The ALIS control GUI and web-application GUI are designed for clear navigation and intuitive operation. The most commonly used control functions for each house sub-system are presented on the first page of the touchscreen control GUI, directing the user clearly toward more precise control for each sub-system. Users interact with the touchscreen using gestures that mimic familiar analog controls, such as dragging a vertical slider up or down to operate shades or dimmable lights. Graphic design of control elements further enhances the intuitive understanding of their functionality. For example, a striped pattern on the background of the exterior shade slider changes dynamically to reflect the open or closed rotation of slats.

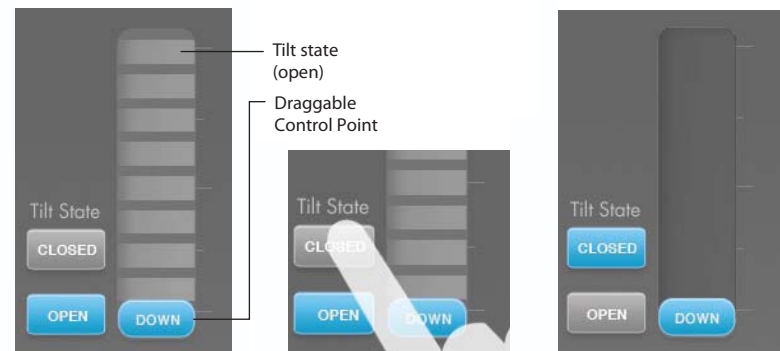

The user control of the exterior shades, like the interior blinds and the dimmable lights, is presented through the graphic of a slider switch on the touchscreen Graphic User Interface. The graphic of the slider changes dynamically to reflect the current state of the shades, the position of the button reflects the extension, while the texture of the slider represents the open or closed state of the slats.

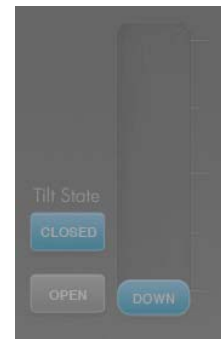

When the user control of a system is restricted (in states of emergency or when that function is unavailable) the control elements are graphically faded and the user cannot interact with them.



When the user overrides the system to a non-optimal configuration, the control point changes from blue to orange. The user can hit the "optimize" button to restore systems to their most optimal configuration. Once optimized, the control point will change colour back to blue.

Figure 3.3: Graphic control elements and are designed to communicate information about the current state of the subsystem, and to be operated intuitively by the inhabitant

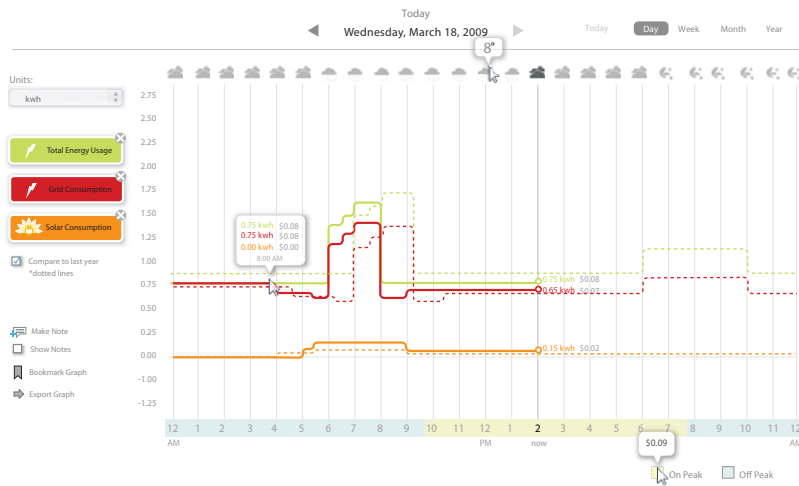

Figure 3.4: Sample of the ALIS web-app graphic visualization of energy use on a daily scale, with 3 measurement variables selected by the user

The web-application has similarly centralized navigation. The first page displays summary information for all features, and detailed data and specific functions are grouped in intuitive thematic arrangements. They interact with the web-application using operations that are commonly used in other desktop applications, such as tabbed browsing through themes and features, “drag-and-dropping” variables onto a graph template, or hovering the mouse over an item to view more detailed information. The same graphics and organization are also translated to the particular viewing size and interaction styles that are suitable for use on a smartphone.

Meaningful feedback

For inhabitants to get the most out of these extensive control and monitoring systems, the feedback must be presented in ways that are meaningful to them. This may mean different things for different people. For example, for many people kilowatts and kilowatt-hours are not meaningful units. Measuring energy use in dollars might be more meaningful to those who pay the bills, but it may be equally abstract to children or tenants who do not pay for their energy use. Measuring resource use in tonnes of CO₂ is also somewhat abstract, but can be a useful way to convert the measurement into terms of ecological impact. Currently the ALIS web-application displays measurements of electrical production and consumption in kWh, dollars, and tonnes of CO₂ emissions. The ALIS platform will allow for additional units to be displayed should there be a demand for it.

Though it is important to understand and design for the fact that kilowatts and tonnes of CO₂ are not meaningful units to everyone, it is also important that designers and educators don’t propagate this condition by “dumbing down” the discourse. Rather, we must make every effort to help people attribute meaning to these figures and units.

Graphic visualization of consumption patterns, along with a detailed breakdown of consumption by use and by time, can vastly improve the legibility of this information, which can in turn help the user to develop a fluency in these abstract units. For example, if an inhabitant were to graph their total energy consumption against the energy consumption of their oven and their desk lamp, they could quickly comprehend the relative intensity of each appliance and its cumulative effect on whole home performance over time. With a good visualization tool, the information is legible regardless of the units; however, should the user take note of the values in kWhs they could easily begin to understand kWhs as meaningful units.

The detailed measurement and graphic visualization on varying timescales allows inhabitants to discover trends in their energy use and to understand how small or large changes in their behaviour impact performance over time. Comparative information, such as local weather, home calendar, and user added annotations, allow inhabitants to contextualize their energy consumption trends with factors that are inside and outside of their control. For example, a spike in electrical consumption may be accounted for by an extra house guest, a severe cold snap in the winter, or a change of habit such as leaving the computer on all night. This data is compiled in the web-application either automatically, in the case of weather patterns or information that is already stored on the house calendar, or manually by the user who can easily add annotation to the graphs.

Lastly, goal setting can be much more meaningful when it is supported by data that assists in setting realistic and attainable goals, and that measures progress toward a goal in real time.

Integration with Life

For inhabitants to sustain energy conscious practices developed through the ALIS it's important that this infrastructure be integrated with their daily routines, habits and rituals. Rather than deliver a whole new set of tools and devices to the user to manage the house, we endeavour to integrate those functions with familiar tools and systems. The smartphone application is an important tool for achieving this goal. While the internet fundamentally changed our relationship to information, and email and the mobile phone changed the way we communicate professionally and socially, the smartphone promises many more lifestyle changes by allowing us to carry the internet in our pocket. Already, people with GPS enabled phones note that getting lost is a thing of the past. Adding a layer of connection to the home and feedback on domestic resource consumption is a natural next step. The habit of using a smartphone is firmly entrenched with much of the population, and for many this habit seems irreversible.

In the home, the Ambient Canvas acts as a constant but non-intrusive reminder of the status of the home which can be seen from anywhere in the open living space.

The calendaring function on the web-app further integrates the home's operations with the inhabitants schedule without adding burdensome mental

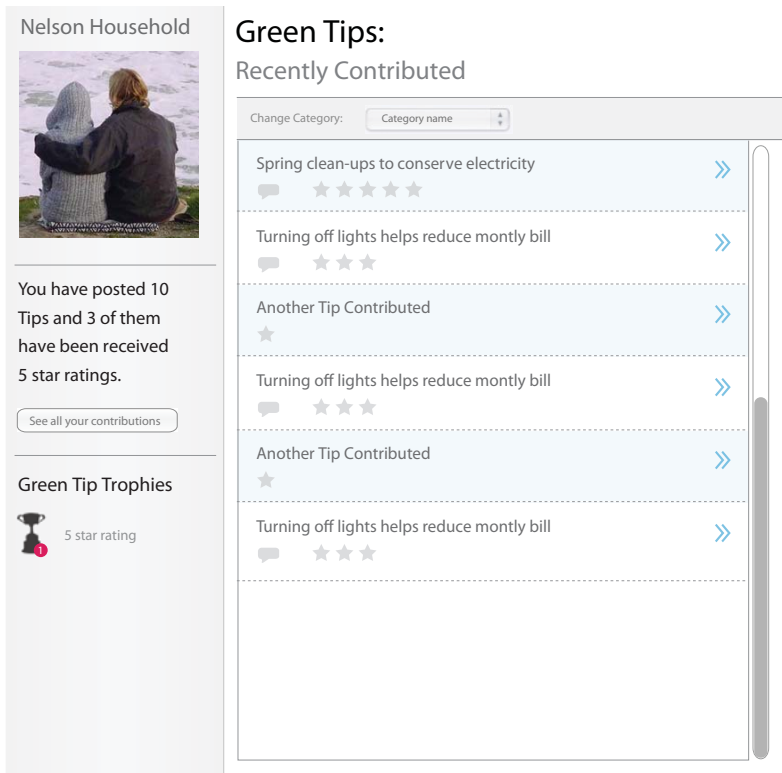

Figure 3.5: Sample of the ALIS web-app Community Network Tips Board

load. Including a social dimension to the ALIS through the community network can also help to make energy conscious living an important part of the inhabitant's existing relationships.

Personal and Social incentives

Using personal and social incentives for achieving improved environmental performance can add pleasure to the long-term use of the ALIS to support energy conscious living. The community network can be a powerful tool for propagating collectively acquired knowledge and values of a community of people working together toward a common goal. Comparisons to other households can enrich goal setting with friendly competition, and may prompt further questioning and reflection on each household's own performance, "Why do we use so much more energy on lights than they do?" Sharing questions and answers also enables the community to pool ideas and resources to everyone's benefit. Lastly, it also acts as an important forum for community members to express their identity, personal values, and accomplishments.

3.4 THE ADAPTIVE LIVING INTERFACE SYSTEM (ALIS)

Three types of user interface components comprise the ALIS. These include touchscreen control panels distributed throughout the house; a web application, extended to a smartphone application for providing detailed graphic information feedback and advanced control options; and an ambient display that provides feedback in subtle, non-intrusive ways.

The touchscreen control panels are located at central and convenient locations throughout the house to provide the resident with immediate and convenient control over their surroundings. A large touchscreen panel PC located in the kitchen provides access to fine grained control of all home systems, while a small touchscreen is positioned at each entrance to offer control of local lights and whole home settings through preconfigured 'modes' that the user can create and modify through the web-application. These small touchscreens send their commands by ethernet to the large touchscreen which distributes commands to the controlled devices. As the North House is a very small residence, three control points are more than enough to service the entire space; however, the system could easily be extended to more control points for larger homes, providing an appropriate degree of control for each location.

The web-application can be accessed through the kitchen touchscreen panel PC, wirelessly in the home through the inhabitant's computer, or through any computer with an internet connection. A similar smartphone application allows ubiquitous access to home monitoring and control. The web-application provides the inhabitants with an array of features, including visualizing resource usage, managing house settings according to 'modes' and schedules, and accessing community networks.

The 'Resource Usage' feature presents graphic visualizations of detailed measurements of energy production, energy consumption by individual appliance or use, total water consumption, and hot water production and consumption. Inhabitants can choose to graph any series of measurements against each other on a daily, weekly, monthly, or yearly timescale, and they can further compare these to their own historical records as well as weather patterns. Added features, such as annotating and bookmarking graphs, allow the user to accumulate a nuanced understanding of the patterns over time.

The 'House Settings' feature allows the inhabitant to control all home systems directly in a nearly identical interface as touchscreen panel PC, and they can



Figure 3.6 The iPhone application allows ubiquitous access to full home monitoring and control.

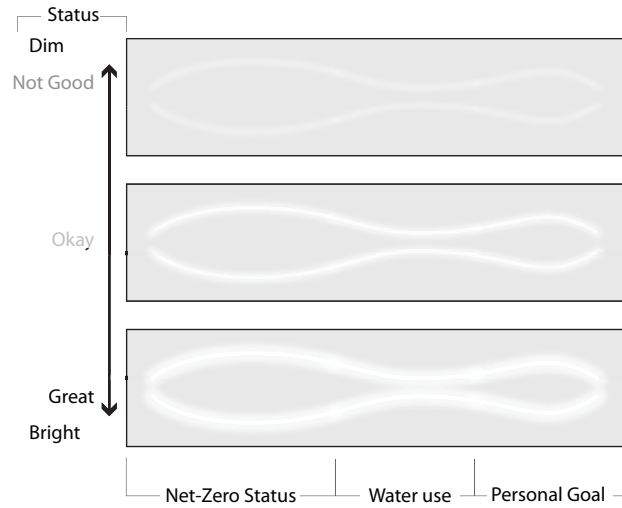

Figure 3.7: The ambient canvas varies in light intensity to subtly communicate information regarding energy and water consumption, and performance relative to a personal goal set by the inhabitant through the web-application

also create and edit ‘modes’ which comprise settings for all of the house systems, and correspond to user activities; these can be as basic as ‘at home’ vs. ‘away’ or as specific as ‘dinner party’, ‘media’ or ‘economy’, for example. Once created, these modes appear on the first page of each of the touchscreen panels, so that the house can be set into a mode with the single press of a button. The modes can be scheduled through the house calendar within the web-application, which can import common calendaring applications such as Google Calendar™ and iCal™ so that the house settings can be easily integrated with the inhabitant’s personal schedule. Of course the prescheduled modes can be modified as necessary. For example, the house may be scheduled to be in ‘away’ mode from 9am until 5pm, but if the inhabitant decides to come home early, they can easily use their smartphone to change the mode en route, so that the house is warm and cozy when they arrive.

The ‘Community Network’ feature is a platform for personal and communal goal setting, friendly competition, and information and resource sharing. Residents can personalize their profile page and select the information that will be made public over the network. They can initiate personal or group challenges or join challenges initiated by others, and they can view participants’ rankings and progress towards achieving the challenge. They can pose questions, post helpful tips or comments, and use the network to share other resources such as carpooling, free-cycling, or bulk purchasing with fellow community members.

Lastly, the Ambient Canvas illuminated backslash subtly delivers visual cues pertaining to the performance of the house in real-time, while also acting as an aesthetic element in its own right. It is comprised of a series of LED rope lights mounted behind a translucent corian surface. The LED glow with varying intensity in different zones according to net-energy consumption/production, water consumption, or performance status relative to a user defined goal.

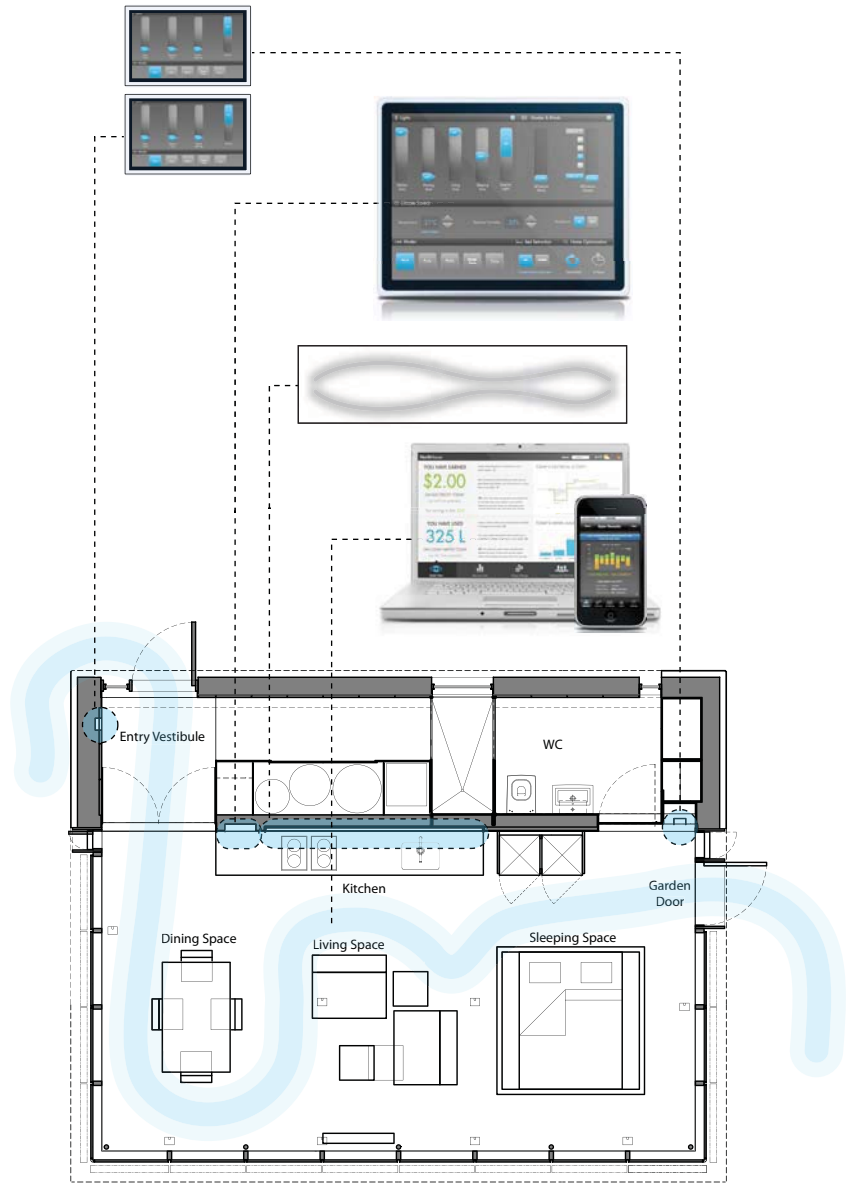
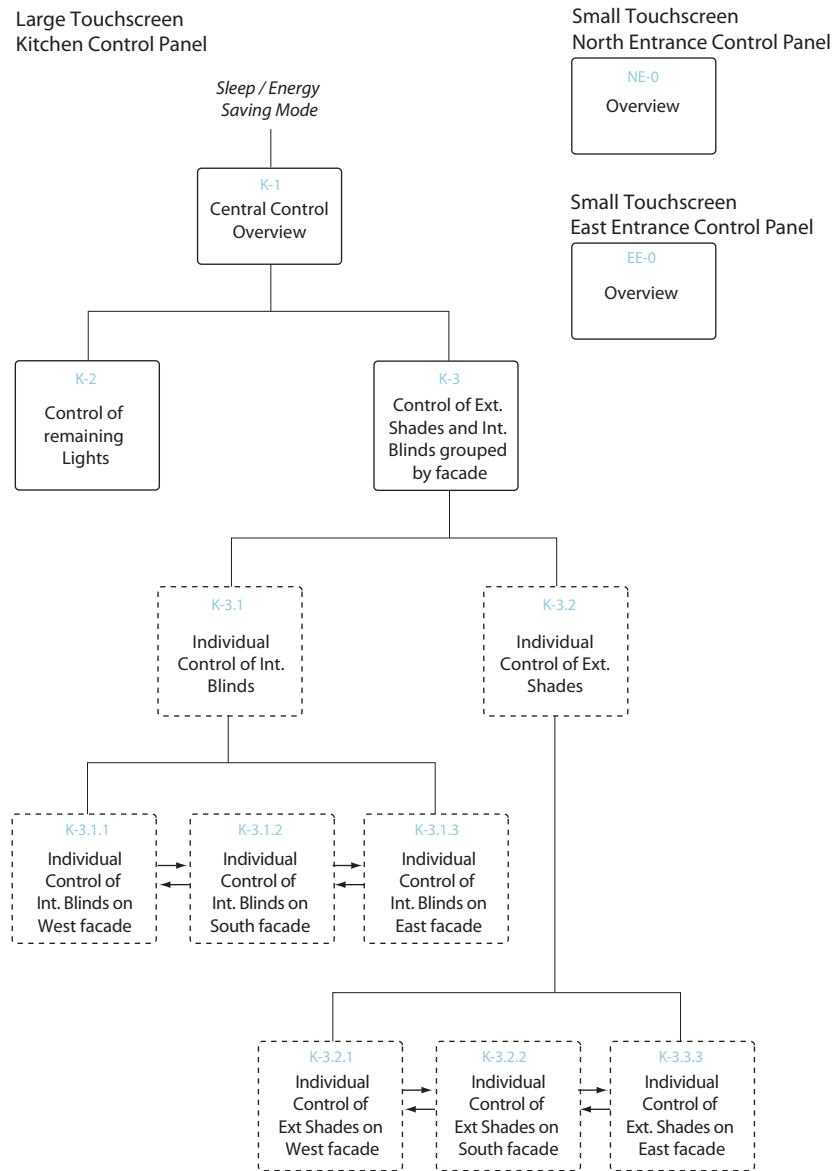

Figure 3.8: Access to ALIS elements within the North House

Navigational hierarchy of the ALIS Touchscreen Control Panel Graphic User Interface (Figure 3.9)



Control Panel GUI page K-1: Overview (Figure 3.10)



- A: Controls for the most commonly used lights. Dimmers are presented with an arrow head and indicate the percentage of the current dim state. When the user drags the slider up or down, text appears next to the arrow point (so that it is not hidden by the finger tip).
- B: Navigate to control of the less commonly used lights.
- C: Controls for the shades and blinds. These sliders function similarly to the light control sliders, and control all shades or blinds as a group. While the blinds or shades are in motion, following a command, the button flashes (from blue to white) to indicate that the slider is disabled until the command has been completed.
- D: Open / Closed buttons control the tilt state of the slats on the shades. The striped graphic on the slider changes to reflect tilt state.
- E: Navigate to further control options for shades and blinds, grouped by facade, or by individual unit - exterior shades can be controlled by upper and lower tilt zones.
- F: Use arrows to change set-points for temperature and humidity or toggle ventilation- boost on or off.
- G: Select user-defined modes as a shortcut to overall house settings. These modes can be set via the web-application.
- H: Control the retraction / deployment of the bed.
- I: House Optimization button returns all systems to their most optimal settings (automated control) removing any current user-overrides.
- J: Timer allows inhabitant to determine when the house should resume optimized / automated control. Allowing them to apply user overrides for any period of time.

Navigational hierarchy of the ALIS Graphic User Interface Web-Application (Figure 3.11)

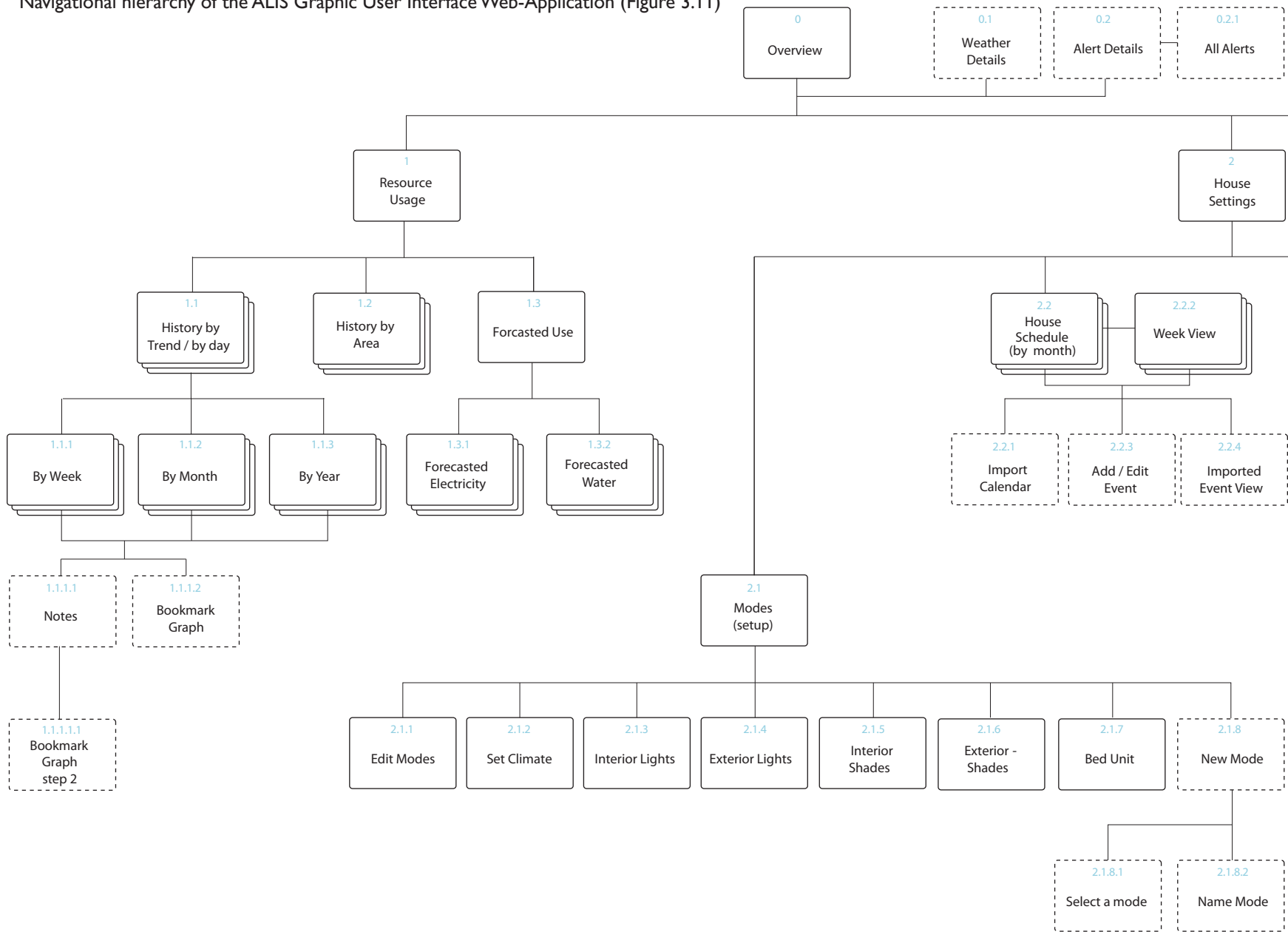

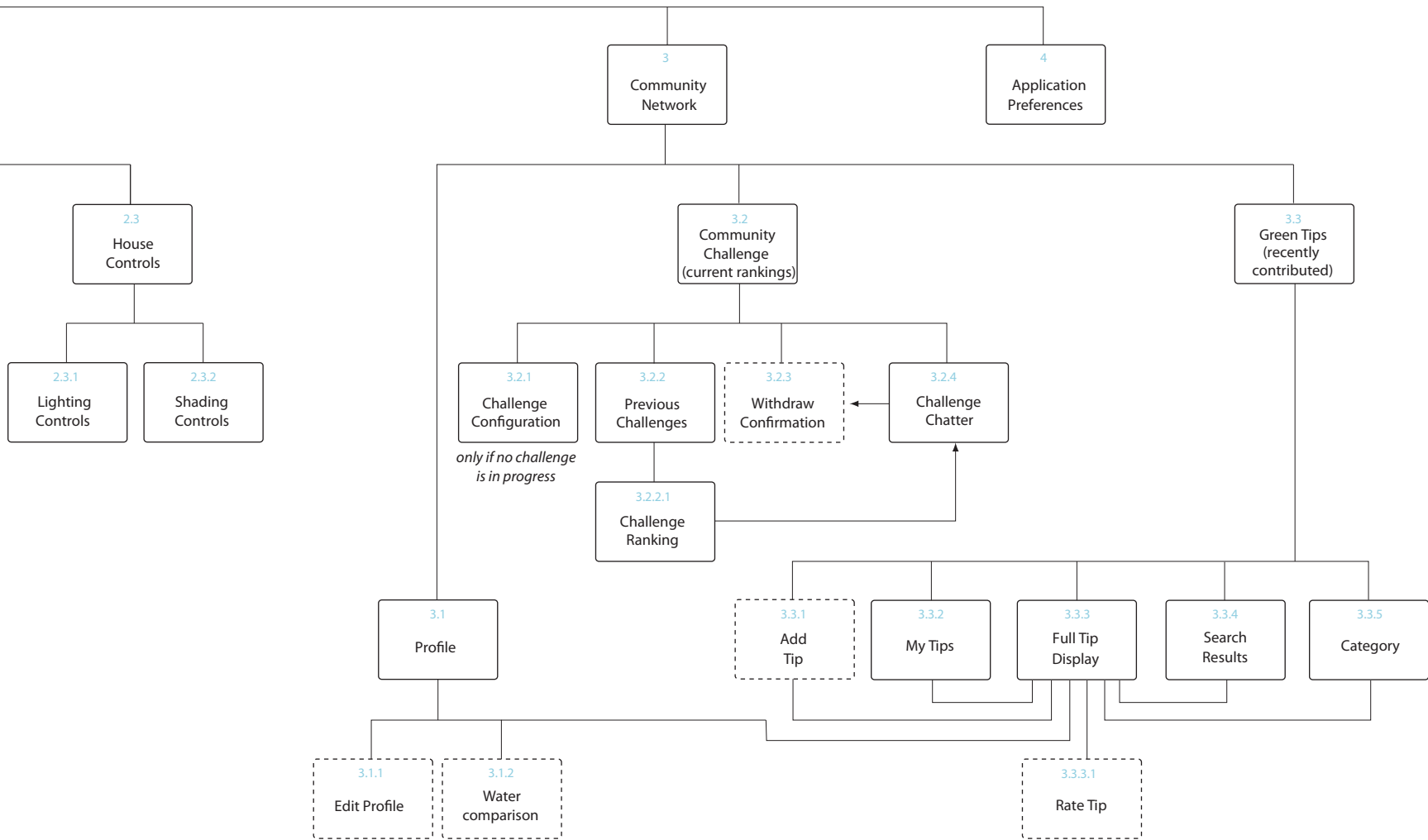

Web App Page 0: Overview (Figure 3.12)

presents summary information at a glance and easy navigation to the rest of the web application

- A: Quick, visible, and easily legible overview information for both net electricity and total water consumption.
- B: Quick facts provide clues to consumption patterns. Clicking on the graph icon navigates to the relevant resource use graph view with more information.
- C: Community challenge overview shows inhabitant's ranking among participants duration of the challenge, and the challenge target.
- D: Clicking here navigates to the community challenge page.
- E: Navigation bar highlights to denote the section that is currently displayed.
- F: Mode selector / display allows inhabitant to set the house in a previously created mode. This displays the current mode of the house, and remains on the header on all pages of the web application.
- G: Current weather conditions display remains on the header on all pages of the web application. Clicking here opens a pop-up with a weather forecast and more information on current conditions.
- H: Alerts / Notifications appear as an icon that is colour coded to reflect the category of recent updates. Clicking the icon opens a pop-up with a summary of 5 most recent alerts. From there, one can navigate to view and edit details on each alert, or view all alerts.

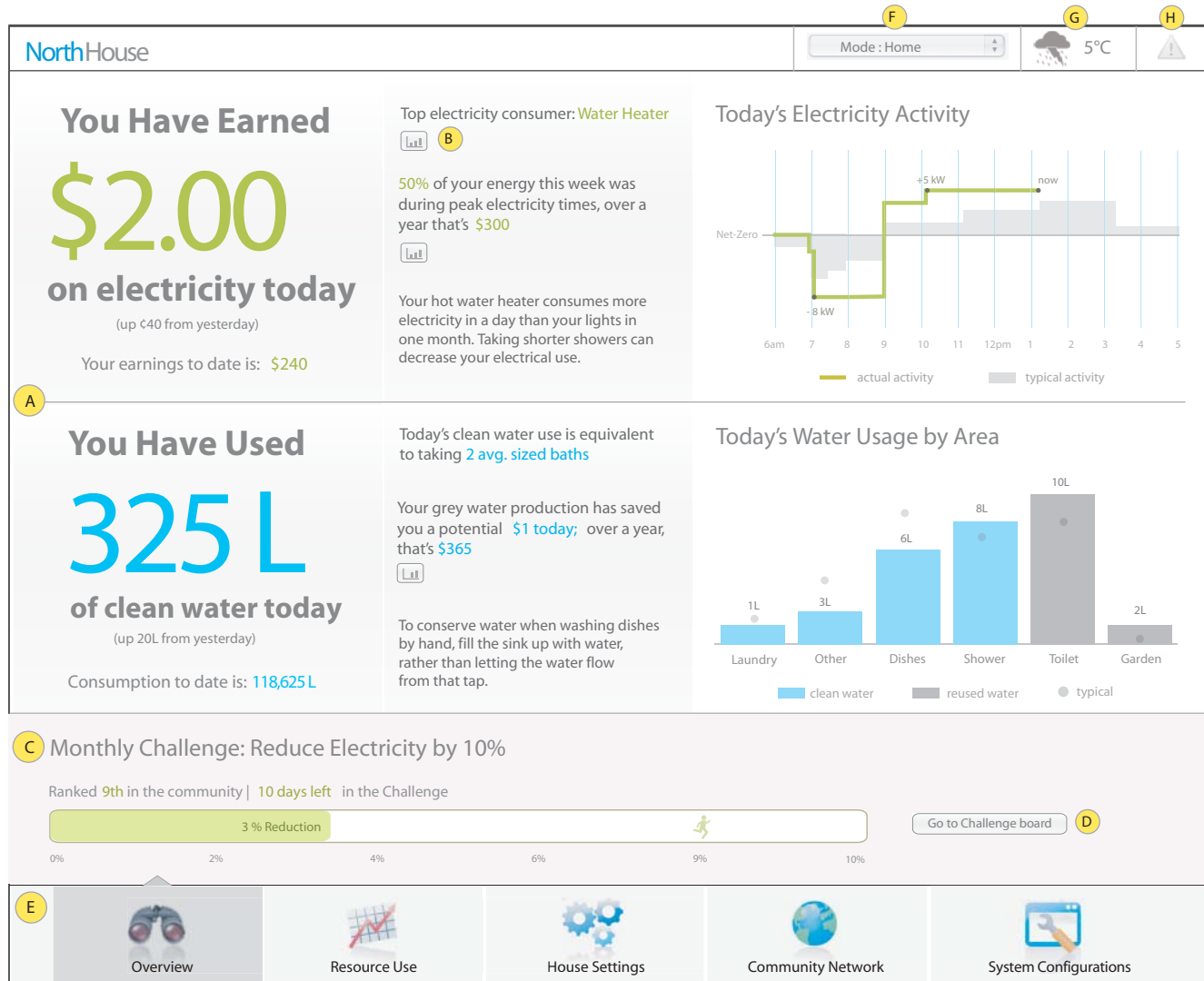

Web App Page 1.1: Resource Usage / History by Trend / By Day (Figure 3.13)
allows users to select, view, and compare data from a set of variables

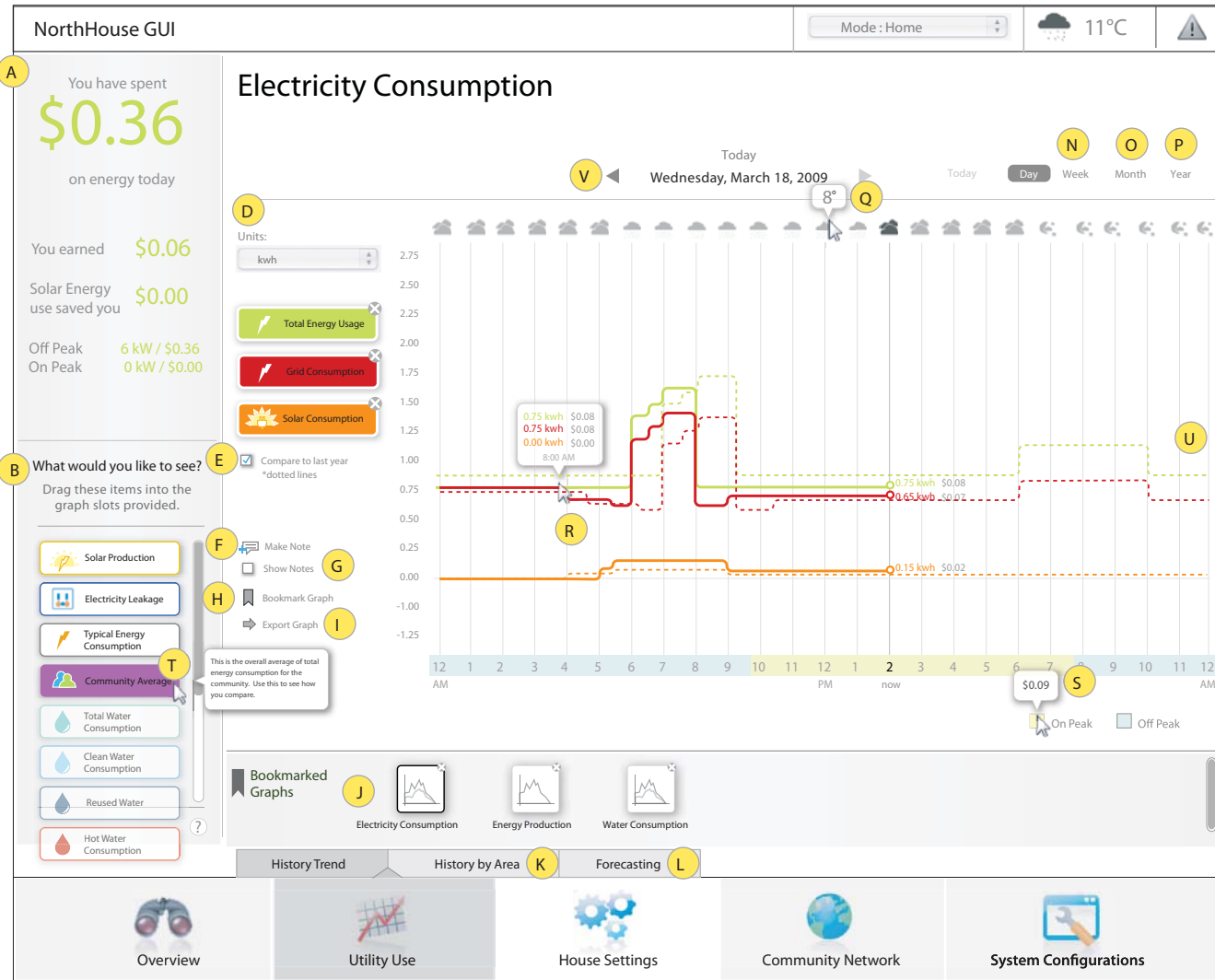

- A: Quick and legible overview of the information displayed on the graph.
- B: Graphable variables. Select and drag them onto the graph to view them. Inhabitants can choose to graph up to 3 variables on a graph. Some variables cannot be graphed together, incompatible variables will be greyed-out based on the current selection.
- C: Title of the graph changes to reflect the selected variables.
- D: Pull-down menu allows inhabitant to choose units for the graph (kWh, \$, tonnes of CO₂, L)
- E: Toggle switch to view last year's data on the same variables.
- F: Click here to make notes directly on the graph. For example " We had 2 house-guests for the month of March - more showers, laundry, and cooking."
- G: Toggle switch to view notes on the graph.
- H: Click here to bookmark the graph.
- I: Click here to export the graph (this feature not yet available).
- J: View a previously saved graph.
- K: Navigate to the History by Area section, which shows energy and water consumption by appliance, and zone.
- L: Navigate to the Forecasting section, which predicts household energy use based on historical usage patterns. (This feature not yet available).
- N: View graph by week.
- O: View graph by month.
- P: View graph by year.
- Q: Roll-over the weather icons to display the average weather from that date.
- R: Roll-over points on the graph to display precise values for that period.
- S: Roll-over legend to display cost/unit.
- T: Roll-over a graph variable to display details about the variable.
- U: If toggle is checked for the "compare last year", a dotted line appears to denote the previous year's data for each variable.
- V: Click the arrow to view the previous week's data.

Web App Page 2.1: House Settings / Modes / Set-up (Figure 3.14)
 allows users to view settings for existing modes, and to create new modes

- A: Existing user-defined modes are displayed as a list. Hovering over each mode displays a description below.
- B: Edit or delete user-defined modes.
- C: Add new modes. Hovering over the button displays an info bubble relating to the function.
- D: Set preferences for each house sub-system in the chosen mode. These controls are displayed similarly to the house controls, but they will only be applied when the particular mode is selected.
- E: Edit the current name, display colour, and description of the selected mode. The display colour is used in the house schedule section.
- H: Navigate to house controls
- K: Navigate to house schedule

Web App Page 2.2 - House Settings / House Schedule / By Month (Figure 3.15)

allows the users to integrate their personal calendar with that of the house, making it easy to set the house into different modes appropriate to their own activities

The screenshot displays the NorthHouse GUI interface. At the top, it shows 'NorthHouse GUI', 'Mode : Home', and '11°C'. The main area features a monthly calendar for March 2009. On the left sidebar, there are two sections: 'Imported Calendars' with checkboxes for 'Google Cal - Work' and 'Google Cal - Play', and 'Modes' with checkboxes for 'I'm Home', 'Away', and 'Sleep'. A pop-up window is overlaid on the calendar, showing event details for a specific date (March 13, 2009), including 'From' (8:30 AM), 'To' (5:00 PM), 'Mode' (Away), and 'Repeat' (Never). The bottom navigation bar contains icons for 'Overview', 'Utility Use', 'House Settings', 'Community Network', and 'System Configurations'.

A: Calendar's can be imported from Google, i-cal, etc. Checkboxes toggle each calendar on or off in the current view. Imported calendar's are read only. (This feature is not yet implemented)

B: Roll-over import button for more info.

C: Create calendar layers that correspond to user-defined house modes. The CHAS will turn modes on and off according to the schedule. Inhabitants can override the pre-defined schedule at any time.

D: Events are displayed in the colour associated with the mode or imported calendar.

E: Click on the arrows to scroll forward or backward by month.

F: Change calendar display to week view.

G: Click on the cell to create a new event, or click on an existing event to view or edit it. A pop-up window appears, allowing the inhabitant to add a new event, set the starting time, ending time, desired mode, and choose to repeat the event on a daily, weekly, or monthly interval. This can be done for modes-events.

Web App Page 3.1: Community Network / Profile (Figure 3.16)
 represents the household to others within the network of ALIS users

- A: Profile image that the user uploads or selects.
- B: List of achievements that the inhabitant has earned through competing in challenges, and through contributing to community "green tips".
- C: Graph provides a quick overview of household consumption compared to the community average. This can display either electricity or water consumption, and can switch between different units.
- D: List of tips recently contributed by the household. These are displayed in reverse-chronological order. If others have commented on the tip, a grey "talk-bubble" will appear.
- E: Clicking on the arrow opens the full tip post within the Green Tip section.
- F: Post a tip through this window, categorize using the pull-down menu on the right.
- G: Navigate to the page where inhabitants can edit their household profile.
- H: Navigate to Challenges page
- I: Navigate to Green Tips page

NorthHouse GUI
Mode : Home
11°C
⚠



A

Achievements

B



10 % Electricity Reduction Challenge

1



10 % Water Reduction Challenge

1



High Rated Green Tip

5

Nelson Household

G [Edit Profile](#)

Electrical Demand Over the Last 7 Days
(Community Average vs. You)

C

Resource:

Electricity

Units:

kwh

Community

You

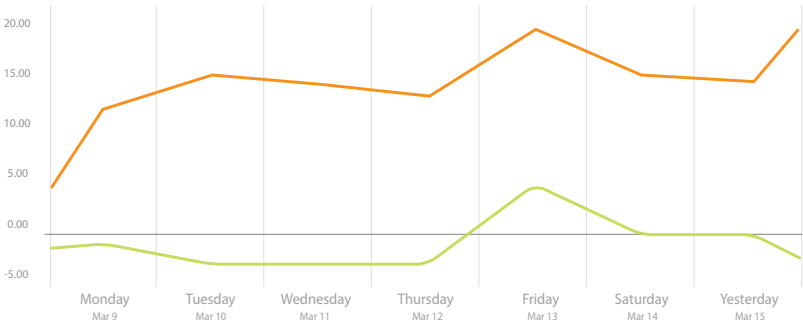

Day	Community (kwh)	You (kwh)
Monday Mar 9	~11	~-1
Tuesday Mar 10	~14	~-2
Wednesday Mar 11	~13	~-2
Thursday Mar 12	~12	~-2
Friday Mar 13	~18	~3
Saturday Mar 14	~14	~-1
Yesterday Mar 15	~19	~-2

Your Recently Posted Tips **D**

Yesterday

Some suggestions for Summer Savings E

March 3, 2009

Using energy star appliances helps »

Turning off lights is easy, just do it! »

Post a Quick Tip **F** Category: Electricity

[Save](#)

Profile

Challenges **H**

Green Tips **I**



Overview



Utility Use



House Settings



Community Network



System Configurations

Wep App Page 3.2: Community Network / Community Challenge / Ccurrent Rankings (Figure 3.17) displays overview information on a current community challenge that the user is participating in

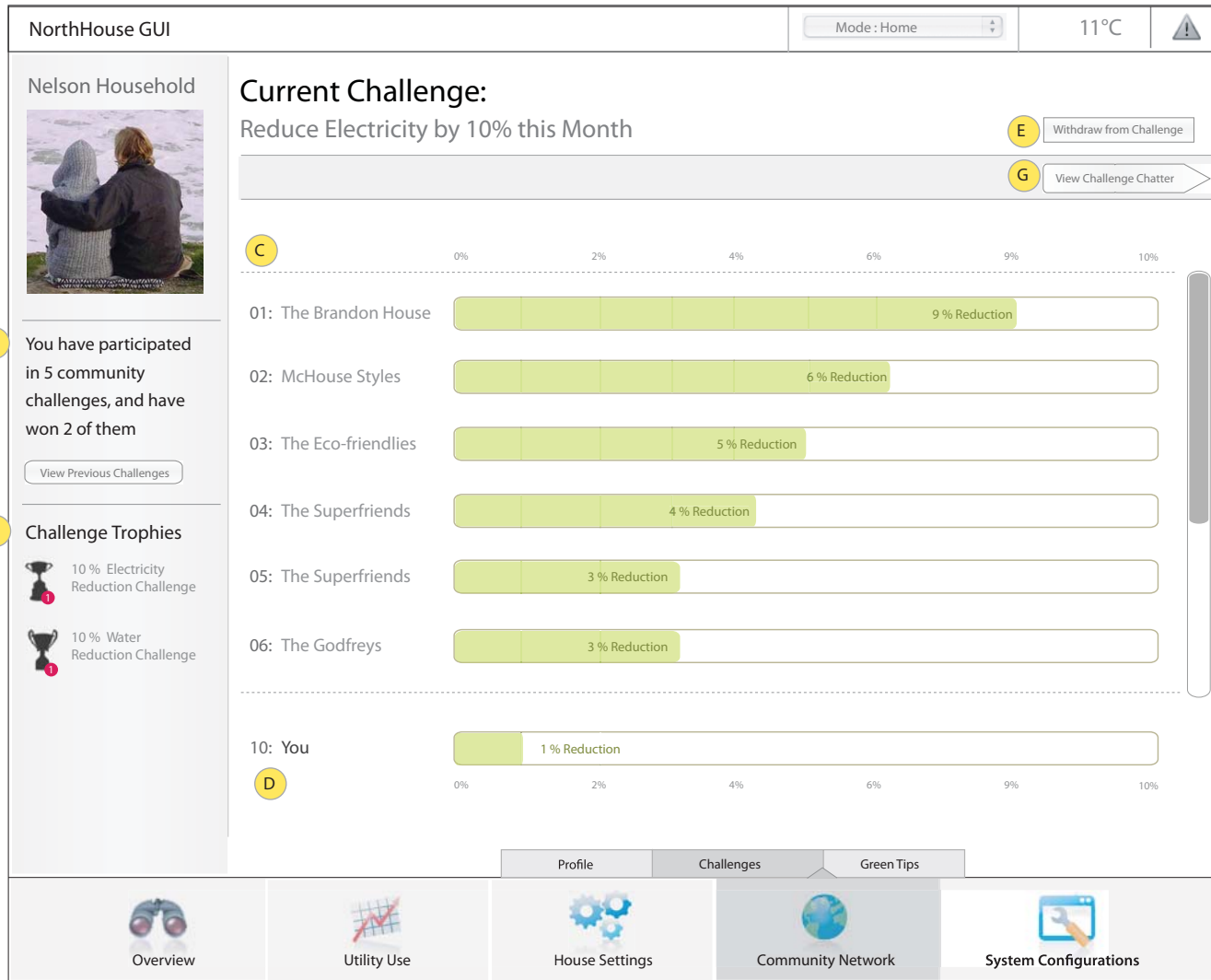

- A: Display of previous interactions in the challenge section, and the level of success in the challenges.
- B: Display of the achievements that are specific to the challenges.
- C: Ranked comparison of each participating household, showing progress relative to the challenge.
- D: User's household progress to date will appear in this zone regardless of ranking.
- E: Click here to withdraw from the competition.
- F: Click here to view conversations occurring within the particular challenge.

Web App Page 3.2.1 - Community Network / Challenge Configuration (Figure 3.18)
allows users to set the terms of their personal or community challenge

A: If the user is not currently in a challenge, this page will appear. Select type, level, and duration of the challenge, and whether you would like to compete against yourself or others.

B: Navigate to the Community Challenge page

The screenshot shows the 'NorthHouse GUI' interface for setting a challenge. At the top, there's a header with 'NorthHouse GUI', a 'Mode: Home' dropdown, '11°C', and a warning icon. The main content area is titled 'Set a goal and challenge yourself!' with a yellow 'A' callout. Below this, there are four form fields: 'What type of challenge do you want to take part in?' (Electricity), 'What kind of goal do you want to attempt?' (Reduce use by 10%), 'How long do you want to take part in this challenge?' (1 week), and 'Do you want to compete with others or against yourself?' (radio buttons for 'Against Others' and 'Against Myself'). A 'Get Started' button with a yellow 'B' callout is at the bottom of the form. On the left sidebar, there's a section for 'Nelson Household' with a photo of two people, a summary of participation ('You have participated in 5 community challenges, and have won 2 of them'), a 'View Previous Challenges' button, and 'Challenge Trophies' including '10 % Electricity Reduction Challenge' and '10 % Water Reduction Challenge'. At the bottom, there's a navigation bar with icons and labels for 'Overview', 'Utility Use', 'House Settings', 'Community Network' (highlighted), and 'System Configurations'. Above the navigation bar, there are tabs for 'Profile', 'Challenges', and 'Green Tips'.

Web App Page3.3: Community Network / Green Tips / Recently Contributed (Figure 3.19) displays an overview of new tips and tools for searching, rating, and commenting on existing tips

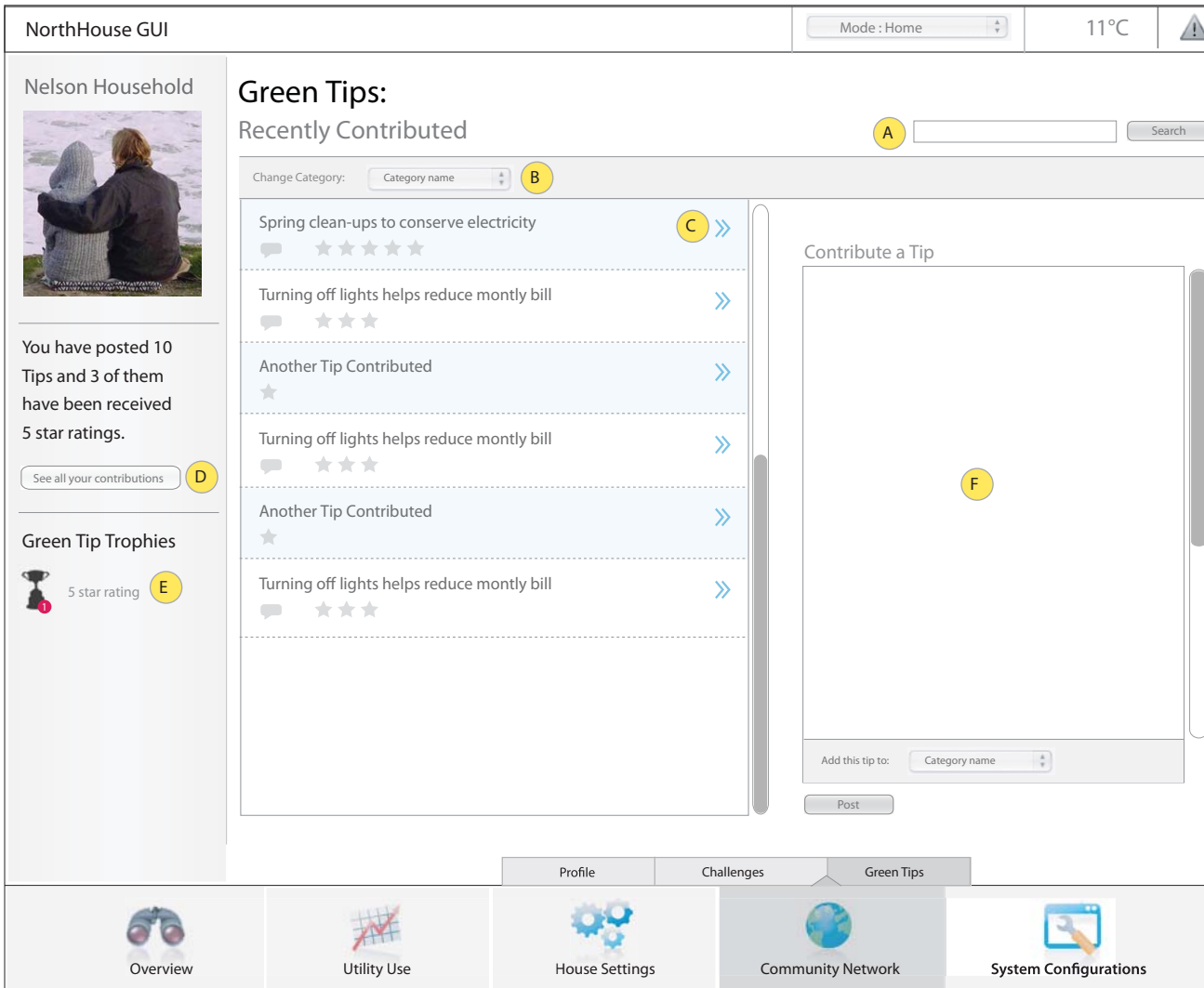

- A: Search all posts for specific tips.
- B: Pull-down menu to select category of tips to view.
- C: Click on the arrow to view complete post, see all comments related to the post, and rate it out of 5 stars.
- D: View and edit tips contributed by the household.
- E: List of achievements that are related to the Green Tips section.
- F: Post a tip to the community, and categorize it using the pull-down menu. Once posted it will appear in the list, where community members will be able to see, rate, and comment on your post.

3.5 THE CENTRAL HOME AUTOMATION SERVER (CHAS)

The Central Home Automation System (CHAS) manages the operation of the ALIS and all of the other subsystems of the house. Depending on the conditions, the CHAS is able to make high-level decisions to enhance the energy performance of the house. For example, the CHAS will determine the operation of the external shading system depending on the interior air temperature of the home, the amount of incoming solar radiation, the exterior wind speeds, and the expected position of the sun. Based on these conditions the CHAS will determine if the house should go into solar heat harvest mode to save on heating energy or solar heat rejection mode to save on cooling energy. Similarly, the CHAS also controls the HVAC system in conjunction with the operation of the exterior shades to maintain thermal comfort while ensuring energy efficiency. For systems which could operate in different states depending on conditions, such as the interior temperature, relative humidity, and exterior shading, a hysteresis control algorithm allows the CHAS to make intelligent decisions based on real-time inputs and the previous state of the system. This ensures smooth transitions between states and avoids frequent chattering between different settings.

In total, the CHAS will interface with and co-ordinate seven systems, including the HVAC, domestic hot water production, exterior shades, interior blinds, lighting, bed retraction, energy monitoring, and the ALIS. Many of the subsystems have their own controllers, which manage the operation of that system to varying degrees. There are two computers that are central to the CHAS, the touchscreen panel PC²³ and the embedded PC²⁴. A useful analogy to distinguish the function of the two computers is to the central nervous system; the touchscreen panel PC is like the brain, controlling the somatic processes, while the embedded PC is like the spinal cord, controlling all of the automatic processes.

The HVAC system is controlled by the embedded PC which collects data from the system sensors and co-ordinates the operations of the heat pumps, circulation pumps, and fans, to deliver the required conditions for thermal comfort set by the occupant through the GUI hosted on the touchscreen panel PC.

The solar thermal collectors are operated by an independent controller²⁵ which sends data to the touchscreen panel PC but receives no commands from it.

The 15 exterior shades are controlled by a set of 15 exterior shade controllers,²⁶ each of which controls two motors on a single blind, and which are connected in series via BACnet.²⁷ They receive commands to initiate solar block, solar gain, or wind safety mode from the embedded PC, or user override commands from the touchscreen panel PC, and they determine the position of the individual shades accordingly.

The 15 interior blinds are controlled by a set of 4 blind controllers,²⁸ each of which controls up to four blinds individually. They are connected in series, and communicate via RS232.

The lights are centrally controlled through a Lighting Control Panel²⁹, which receives commands from the touchscreen panel PC, and controls lights by zones. All lights in the main living area are dimmable, offering a range of lighting conditions and ensuring that energy is not wasted on providing unnecessary levels of illumination. Although the user controls the bathroom lights by wall switches at the bathroom entrance, the bathroom lights also run through the lighting controller so that these can be managed through the house modes. For example, *Away* mode could ensure that all lights are turned off. An added feature of running the bathroom lights through the central controller is that the embedded PC can monitor the light state and run the ventilation when bathroom lights are on, continuing for 5 minutes after the lights are turned off. This way, excess moisture and odour can be ventilated away without risk of forgetting to turn the fan off and without wasting energy on lighting when it is unnecessary. The only light that is not centrally controlled is a nightlight in the bathroom, which is operated by a timed daylight and motion sensor.

The bed retraction system consisted of a modified garage door opener, which receives commands as low-voltage signals from the embedded PC, and also had a remote control as back-up.

Lastly, energy monitoring was performed by a Branch Circuit Power Meter (BCPM),³⁰ a device that is installed with the main electrical load center, measuring the current, voltage, and energy consumption of each circuit. The BCPM measured both the power consumption as well as power produced by the PV system. This was another innovative feature, as this piece of equipment is typically used for industrial (3-phase) applications and therefore needed to be adapted for residential application.

Overview of the Central Home Automation Server, Adaptive Living Interface System, and their integration with North House sub-systems (Figure 3.20)

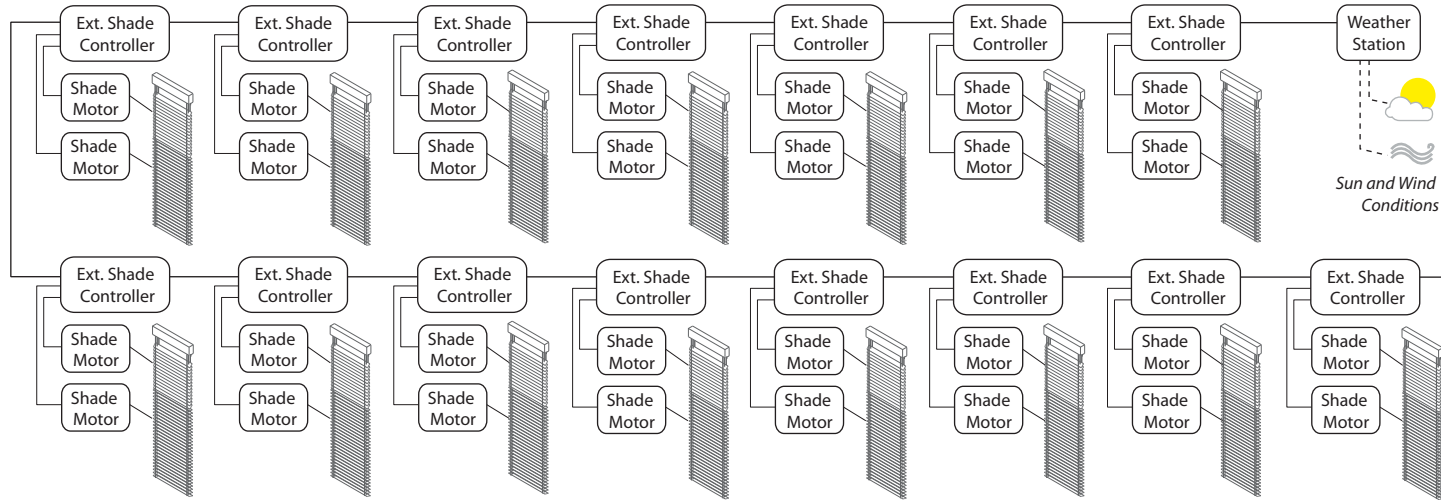

Exterior Shade Control Sub-System

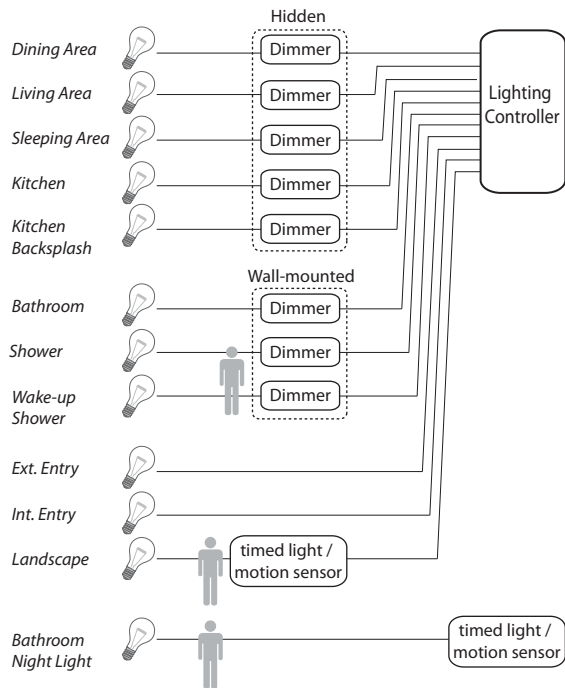

Lighting Control Sub-System

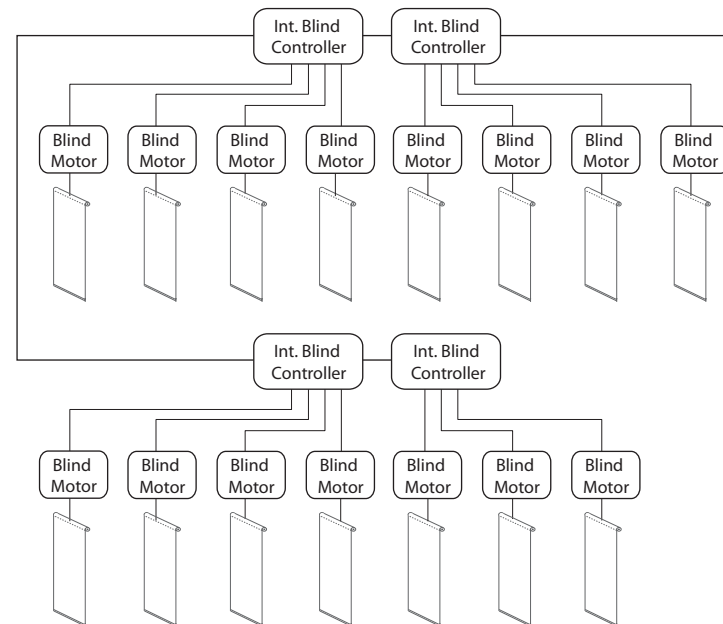

Interior Blind Control Sub-System

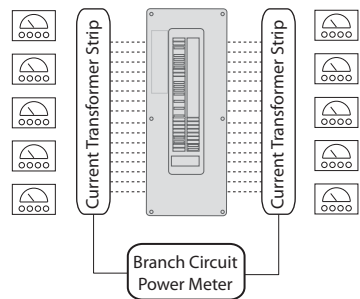

Power Monitoring Sub-System

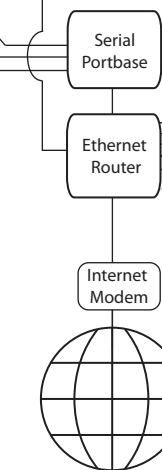

Central Control System

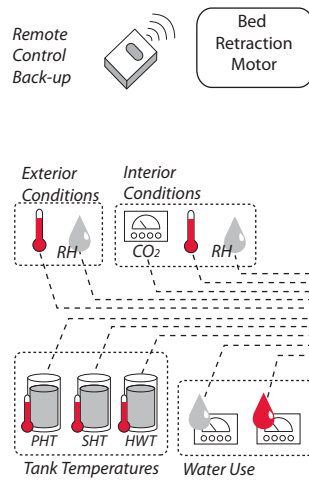

HVAC and DHW Control Sub-System

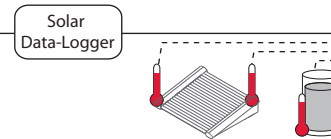

Adaptive Living Interface System

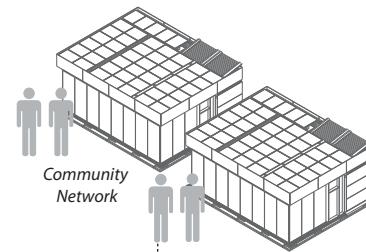
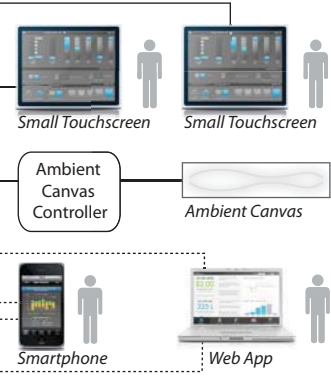
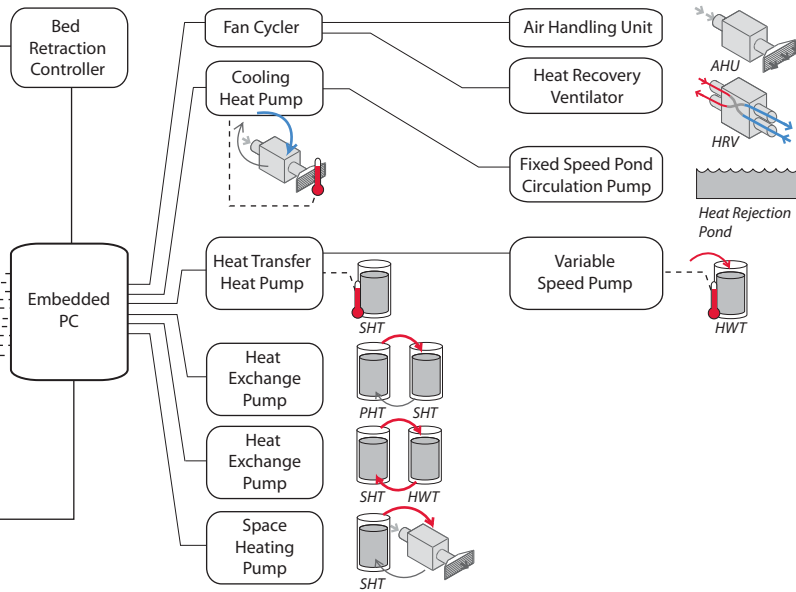

- 1 Kevin Muise, Jin Fan, and Jenny Thai, *North House Graphical User Interface: Industry Review Document*, Anonymous, (2008)
- 2 “GE: Energy Monitoring Dashboard,” in General Electric Co. [database online]. Fairfield CT [cited 2010]. Available from <http://www.ge.com/yourhome/dashboard.html>.
- 3 “Agile Waves: Resource Monitor: Multi-Unit Residential Applications,” in Agile Waves [database online]. Menlo Park, CA [cited 2010]. Available from <http://www.agilewaves.com/resource-monitor-multi-unit-residential/>.
- 4 “Control4: Solutions Overview,” in Control4 [database online]. Salt Lake City UT [cited 2010]. Available from <http://www.control4.com/solutions/>.
- 5 “Home Manageables: Overview,” in HomeManageables Inc. [database online]. [cited 2010]. Available from <http://www.homemanageables.com/overview.php>.
- 6 “Crestron: e-control Overview,” in Crestron Electronics Inc. [database online]. Rockleigh NJ [cited 2010]. Available from http://www.crestron.com/solutions/e-control_for_browser_mobile_pda_pc_interfaces/default.asp.
- 7 “Lagotek Home Systems: Remote control of cameras, lighting, blinds, shades, and climate,” in Lagotek Corp. [database online]. Bellevue WA [cited 2010]. Available from <http://www.lagotek.com/index.html?currentSection=TouchIt>.
- 8 “HAI Products Overview,” in HAI [database online]. New Orleans LA [cited 2010]. Available from http://www.homeauto.com/Products/products_main.asp.
- 9 “Embedded Automation: Home Automation (mHome products),” in Embedded Automation Inc. [database online]. Surrey BC, Canada [cited 2010]. Available from <http://www.embeddedautomation.com/EAHAMain.htm>.
- 10 “ethical superstore: Ecosavers Energy Meter,” in EthicalSuperstore.com Ltd. [database online]. Gateshead UK [cited 2010]. Available from <http://www.ethicalsuperstore.com/products/ecosavers/ecosavers-energy-meter/>.
- 11 “Quality Attributes Software: iBPortal,” in Quality Attributes [database online]. Ames, IA [cited 2010]. Available from <http://www.qualityattributes.com/ibportal/overview/>.
- 12 *Agile Waves: Resource Monitor: Multi-Unit Residential Applications*,
- 13 *GE: Energy Monitoring Dashboard*,
- 14 “Manodo: Sbox,” in Manodo AB [database online]. Sweden [cited 2010]. Available from http://en.manodo.se/manodo_en/index.cfm/products/sbox/.
- 15 “Energy Hub: For Consumers,” in Energy Hub Inc. [database online]. [cited 2010]. Available from <http://www.energyhub.net/consumers/>.
- 16 “The Greener Grass: Concept - Current State,” in The Greener Grass [database online]. [cited 2010]. Available from <http://www.thegreenergrass.org/2008/02/concept-current-state.html>.
- 17 *Manodo: Sbox*,
- 18 Kathy Velikov and Lyn Bartram, “North House: Developing Intelligent Building Technology and User Interface in Energy Independent Domestic Environments,” in *Architecture, Energy and the Occupant's Perspective - Proceedings of the 26th conference on Passive and Low Energy in Architecture (PLEA)*, eds. Claude Demers and Andre Potvin. Anonymous (Quebec, Canada: Les Presses de l'Universite Laval, 2009), 80-85.
- 19 *ibid.*
- 20 Raymond J. Cole and Zosia Brown, “Human and Automated Intelligence in Comfort Provisioning,” in *Architecture, Energy and the Occupant's Perspective - Proceedings of the 26th conference on Passive and Low Energy in Architecture (PLEA)*, eds. Claude Demers and Andre Potvin. Anonymous (Quebec, Canada: Les Presses de l'Universite Laval, 2009), 18-21.
- 21 Gail S. Brager and Richard J. de Dear, “Historical and Cultural Influences on Comfort Expectations,” in *Buildings, Culture and Environment : informing local and global practices*, eds. Raymond Cole and Richard Lorch. Anonymous (Oxford, UK ; Malden, MA: Blackwell Pub., 2003), 175-201.
- 22 Marshini Chetty, David Tran, and Rebecca E. Grinter, “Getting to Green: Understanding Resource Consumption in the Home,” *UbiComp* 344, no. Proceedings of the 10th international conference on Ubiquitous computing (2008): 242-251.
- 23 Brand and model number of panel pc
- 24 Beckhoff CX1010-0111
- 25 Veissman Vitosol 200-T Direct flow vacuum tube collectors
- 26 Embeddia Technologies Dynamic Façade Controller
- 27 BACnet is a communications protocol for Building Automation and Control networks. It provides mechanisms for computerized building automation devices to exchange information.
- 28 Draper Intelliflex SPGC4 controllers
- 29 Lightolier Brilliance II
- 30 Schneider Electric PowerLogic BCPMA

CONCLUSION

The onset of global climate change due to human-caused green house gas emissions is now an internationally recognized truth. The growing list of threats to the biosphere, and the concurrent depletion of energy resources has resulted in a far reaching imperative to drastically increase energy conservation efforts throughout all spheres of industry, politics, and society.

The building sector accounts for almost half of total energy consumption in most developed northern countries, and thus presents one of the greatest opportunity for conservation. New advances in renewable energy and energy efficient building technologies combined with increased public awareness are radically expanding opportunities to create Net-Zero, or Near-Zero buildings. However, energy conservation in buildings is achieved not only by implemented technology, but also by informed patterns of use. Effective design solutions for energy conservation in buildings must therefore consider both the technology itself and the knowledge, aptitude, and needs of the people using it.

This thesis proposed that the paradigm of Interactive Architecture offers a useful point of entry to an expanded scope of architectural design which includes not only the building, but its interactions with the inhabitant and the exterior environment.

North House is an example of design within this paradigm, demonstrating two strategies that incorporate feedback and response: an envelope system that automatically manages passive solar gain by responding to climatic conditions, solar cycles, and occupant inputs; and a control and monitoring interface that provides the inhabitant with easy control and meaningful feedback on the impact of their behaviour.

The preceding chapters describe the DReSS and ALIS in detail, including the initial design ambitions, the guiding design principles, and the details of the implemented systems. Particular emphasis is placed on the mechanisms by which they use or deliver feedback from the inhabitant and the exterior environment to achieve the goal of energy conservation. The descriptions of these systems are not intended to prescribe a singular solution to the problem of energy consumption in buildings. Rather, they are offered as a case study to demonstrate how architects can take responsibility for the inherently dynamic social and environmental interaction that all buildings implicitly engage in. In the North House, the interactive paradigm has been employed specifically to the goals of creating a healthy, beautiful and stimulating domestic environment that uses little energy to operate and also supports the inhabitant in living an energy conscious lifestyle.

What can we still hope to learn from the North House prototype? Though the performance of the house throughout the Solar Decathlon Competition was promising, the house and its systems have not yet been tested through the range of climate extremes for which it was designed. Neither has it been tested as a domestic environment with a living inhabitant. Hopefully, once reassembled and inhabited, long-term testing and monitoring will prove that the North House can achieve the performance that our building energy simulations lead us to expect. Post-occupancy monitoring can provide much needed data to the design industry, helping to refine design assumptions as well as energy simulation tools, and to enhance our understanding of the performance of the inhabited building in its context.

Beyond the prototype phase, we can begin to speculate on the implications of mass distribution of systems like the DReSS and the ALIS. Even if limited to the residential sector, a critical mass of these types of systems could achieve significant energy reductions. A large community of increasingly energy aware building inhabitants could also carry knowledge and informed behaviour outside of their home, to their workplace and social life, fostering an embedded culture of energy consciousness.

As a grid-tied system, the North House is also a natural partner to smart-grids and smart-metering technologies under development in many jurisdictions. As these technologies are still being developed, the definition, ambition, and strategies of implementation vary widely. Generally speaking, a smart grid monitors energy production, distribution, and consumption using two-way

digital communication technology. Proposed advantages of the smart grid are demand-side management to curtail peak-usage periods using time-of-day metering and higher priced energy during peak hours; managing multiple inputs from large and small scale energy producers to better incorporate the intermittent production renewable energy sources such as PV, wind, wave, and micro-hydro; and load-shedding to prevent system failures such as large-scale brown-outs, and to maintain power to critical facilities (such as hospitals or fire stations) in emergency situations.

If connected to an in-home infrastructure such as the ALIS and CHAS, the information delivered by the grid could be communicated clearly to the user, and incorporated in the home control strategy, for example running appliances or charging hot water heaters at times of low grid demand. Because the ALIS monitors power consumption by circuit and appliance it could also send critical information back to the grid, allowing it to distinguish between critical and non-critical operations so that in load-shedding circumstances appropriate circuits can be turned off while others remain powered. Collecting and aggregating this information on the scale of the grid, would also certainly be of value for advanced demand management. This coupled with a community of energy aware building inhabitants could make a great contribution to energy conservation without compromising quality of life.

The North House project declares an unabashedly technophilic attitude to sustainable architecture. This attitude is gaining increasing popularity in the green movement, while in some ways also distancing it from earlier generations of sustainable design. This is consistent with an increasing trend toward technologization in all aspects of our cultural, social, and economic activities, and it warrants careful consideration as to the overall cost and benefits of living in a technologically saturated culture. Though the North House employs systems that are far more sophisticated than those found in an average home, it attempts to strike a careful balance in which the use of technology is not frivolous gadgetry but serves purposes that are very clear to the inhabitants (and the designers). The North House's DReSS and ALIS, as well as the other relatively complex systems, each serve the goals of creating a healthful and stimulating home, while conserving energy and teaching the occupant to do the same.

Together, these system make passive solar strategies available to a far broader range of people, and enable inhabitants to intelligently use sophisticated energy saving and energy producing technologies. The DReSS is particularly important, as it transforms highly glazed facades from their typical role as energy liabilities into net-energy producers. As there is clearly an appetite for highly glazed facades, and many legitimate reasons for this desire in our northern climate, this is an innovation with much potential application.

BIBLIOGRAPHY

- “Agile Waves: Resource Monitor: Multi-Unit Residential Applications.” in Agile Waves [database online]. Menlo Park, CA [cited 2010]. Available from <http://www.agilewaves.com/resource-monitor-multi-unit-residential/>.
- “Building Dashboard for Homes.” in Lucid Designs Group Inc. [database online]. Oakland CA [cited 2010]. Available from <http://www.luciddesigngroup.com/homes.php>.
- “Control4: Solutions Overview.” in Control4 [database online]. Salt Lake City UT [cited 2010]. Available from <http://www.control4.com/solutions/>.
- “Crestron: E-Control Overview.” in Crestron Electronics Inc. [database online]. Rockleigh NJ [cited 2010]. Available from <http://www.crestron.com/solutions/e-control-for-browser-mobile-pda-pc-interfaces/default.asp>.
- “Current Cost: Products.” in Current Cost Corp. [database online]. UK [cited 2010]. Available from <http://www.currentcost.com/products.html>.
- “Embedded Automation: Home Automation (mHome Products).” in Embedded Automation Inc. [database online]. Surrey BC, Canada [cited 2010]. Available from <http://www.embeddedautomation.com/EAHAMain.htm>.
- “Energy Hub: For Consumers.” in Energy Hub Inc. [database online]. [cited 2010]. Available from <http://www.energyhub.net/consumers/>.
- “Ethical Superstore: Ecosavers Energy Meter.” in EthicalSuperstore.com Ltd. [database online]. Gateshead UK [cited 2010]. Available from <http://www.ethicalsuperstore.com/products/ecosavers/ecosavers-energy-meter/>.
- “Fat Spaniel: Interactive Views and Demos.” in Fat Spaniel Technologies Inc. [database online]. San Jose, CA [cited 2010]. Available from <http://www.fatspaniel.com/fat-spaniel-in-action/interactive-views-demos/>.
- “GE: Energy Monitoring Dashboard.” in General Electric Co. [database online]. Fairfield CT [cited 2010]. Available from <http://www.ge.com/yourhome/dashboard.html>.
- “HAI Products Overview.” in HAI [database online]. New Orleans LA [cited 2010]. Available from http://www.homeauto.com/Products/products_main.asp.
- “Home Manageables: Overview.” in HomeManageables Inc. [database online]. [cited 2010]. Available from <http://www.homemanageables.com/overview.php>.
- “Manodo: Sbox.” in Manodo AB [database online]. Sweden [cited 2010]. Available from http://en.manodo.se/manodo_en/index.cfm/products/sbox/.
- “Pulse: Smart.Home Overview.” in Pulse Technologies Inc. [database online]. Dubai UAE [cited 2010]. Available from <http://www.pulseliving.com/index.php?content=1&category=7>.
- “Quality Attributes Software: IBPortal.” in Quality Attributes [database online]. Ames, IA [cited 2010]. Available from <http://www.qualityattributes.com/ibportal/overview/>.
- “Soltrex: Renewable Energy Systems Monitoring.” in Conservation Services Group [database online]. Westborough MA [cited 2010]. Available from <http://www.soltrex.com/>.
- “This is Ecorio.” [cited 2010]. Available from <http://www.ecorio.org/>.
- Architecture, Energy and the Occupant's Perspective - Proceedings of the 26th Conference on Passive and Low Energy in Architecture (PLEA)*. Edited by Claude Demers and Andre Potvin. Quebec, Canada: Les Presses de l'Universite Laval, 2009.

- “The Building Sector: A Hidden Culprit.” in *Architecture 2030* [database online]. [cited 2010]. Available from http://www.architecture2030.org/current_situation/building_sector.html.
- “Lagotek Home Systems: Remote Control of Cameras, Lighting, Blinds, Shades, and Climate.” in Lagotek Corp. [database online]. Bellevue WA [cited 2010]. Available from <http://www.lagotek.com/index.html?currentSection=TouchIt>.
- Biophilic Design : The Theory, Science, and Practice of Bringing Buildings to Life*. Kellert, Stephen R.; Heerwagen, Judith; Mador, Martin ed. Hoboken, N.J.: Wiley, 2008.
- “The Greener Grass: Concept - Current State.” in *The Greener Grass* [database online]. [cited 2010]. Available from <http://www.thegreenergrass.org/2008/02/concept-current-state.html>.
- Intelligent Buildings : Design, Management and Operation*. Edited by Derek Clements-Croome. London: Thomas Telford, 2004.
- Buildings, Culture and Environment : Informing Local and Global Practices*. Edited by Raymond Cole and Richard Lorch. Oxford, UK ; Malden, MA: Blackwell Pub., 2003.
- Architectureproduction*. Edited by Joan Ockman and Beatriz Colomina. New York, NY: Princeton Architectural Press, 1988.
- Cedric Price*. -. London: Architectural Association, 1984.
- “Delta PCM Smart Temperature Management.” in Cosella Dorkin Products [database online]. [cited 2010]. Available from <http://www.cosella-dorkin.com/bvf-ca-en/products/pcm/index.php>.
- Alders, Noortje, Stanley Kurvers, and Hans Cauberg. “Comfort Delivery on Demand: An Adaptive Approach to Comfort Systems in Dwellings.” In *Architecture, Energy and the Occupant's Perspective - Proceedings of the 26th Conference on Passive and Low Energy in Architecture (PLEA)*. Edited by Claude Demers and Andre Potvin. Quebec, Canada: Les Presses de l'Universite Laval, 2009, 96-101.
- Bachelard, Gaston, and M. Jolas. *Poetics of Space*. Boston: Beacon Press, 1994.
- Banham, Reyner. *Architecture of the Well-Tempered Environment*. 2nd ed. Chicago: University of Chicago Press, 1984.
- Banham, Reyner. “A Home is Not a House.” In *Meaning in Architecture*. Edited by Charles Jencks, George Baird and William Dendy. London: Barrie & Rockliff, The Cresset Press, 1969, 109-118.
- Becker, Lawrence J. “Joint Effect of Feedback and Goal Setting on Performance: A Field Study of Residential Energy Conservation.” *Journal of Applied Psychology* 63, no. 4 (1978): 428-433.
- Bordass, Bill, Adrian Leaman, and Steve Willis. *Control Strategies for Building Services: The Role of the User*. Buildings and the Environment conference (BRE), 1994.
- Brager, Gail S., and Richard J. de Dear. “Historical and Cultural Influences on Comfort Expectations.” In *Buildings, Culture and Environment : Informing Local and Global Practices*. Edited by Raymond Cole and Richard Lorch. Oxford, UK ; Malden, MA: Blackwell Pub., 2003, 175-201.
- Brodey, Warren. “The Design of Intelligent Environments: Soft Architecture.” *Landscape Autumn*, (1967): 8-12.
- Brodey, W., and N. Lindgren. “Human Enhancement through Evolutionary Technology.” (1967).
- Brown, G. Z. “Pleasure and Performance.” In *Architecture, Energy and the Occupant's Perspective - Proceedings of the 26th Conference on Passive and Low Energy in Architecture (PLEA)*. Edited by Claude Demers and Andre Potvin. Quebec, Canada: Les Presses de l'Universite Laval, 2009, 343-345.
- Callaghan, Vic, Graham Clarke, and Jeanette Chin. “Some Socio-Technical Aspects of Intelligent Buildings and Pervasive Computing Research.” *Intelligent Buildings International*, no. 1 (2009): 56-74.

- Chetty, Marshini, David Tran, and Rebecca E. Grinter. "Getting to Green: Understanding Resource Consumption in the Home." *UbiComp* 344, no. Proceedings of the 10th international conference on Ubiquitous computing (2008): 242-251.
- Cole, Raymond J. "Green Buildings - Reconciling Technological Change and Occupant Expectations." In *Buildings, Culture and Environment : Informing Local and Global Practices*. Edited by Raymond Cole and Richard Lorch. Oxford, UK ; Malden, MA: Blackwell Pub., 2003, 57-82.
- Cole, Raymond J., and Zosia Brown. "Human and Automated Intelligence in Comfort Provisioning." In *Architecture, Energy and the Occupant's Perspective - Proceedings of the 26th Conference on Passive and Low Energy in Architecture (PLEA)*. Edited by Claude Demers and Andre Potvin. Quebec, Canada: Les Presses de l'Universite Laval, 2009, 18-21.
- Cole, Raymond J., and Zosia Brown. "Reconciling Human and Automated Intelligence in the Provision of Occupant Comfort." *Intelligent Buildings International*, no. 1 (2009): 39-55.
- Cook, Diane J., and Sajal K. Das. "How Smart are our Environments? an Updated Look at the State of the Art." *Pervasive and Mobile Computing* 3, no. 2 (2007): 53-73.
- Darby, Sarah. *The Effectiveness of Feedback on Energy Consumption*. Oxford: Environmental Change Institute, 2006.
- Eastman, Charles M. "Adaptive-Conditional Architecture." In *Design Participation*. Edited by Nigel Cross. London: Academic Editions, 1972, 51-57.
- Elkadi, Hisham. "Ecological Approach for the Evaluation of Intelligence Energy Features in a Building's Skin." *Renewable & Sustainable Energy Reviews*, no. 4 (2000): 91-103.
- Fanger, P. O. *Thermal Comfort; Analysis and Applications in Environmental Engineering*, by P.O. Fanger. Copenhagen: Danish Technical Press, 1970.
- Foley, Georgina, and Living Steel. *Houses of Steel: Living Steel's international architecture competitions*. Mulgrave, Vic: Images Publishing, 2009.
- Fox, Michael, and Miles Kemp. *Interactive Architecture*. 1st ed. New York: Princeton Architectural Press, 2009.
- Gerlach, K. "Environmental Design to Counter Occupational Boredom." *Journal of Architectural Research* 3, no. 3 (1974): 15-19.
- Glanville, R. "An Intelligent Architecture." *Convergence* 7, no. 2 (2001): 12-25.
- Haraway, Donna. *A Cyborg Manifesto: Science, Technology and Socialist-Feminism in the Late Twentieth Century [Electronic Version]*.
- Heron, W. "The Pathology of Boredom." *Scientific American* 196, no. 1 (1957): 52-57.
- Hollands, K. G. Terry, J. L. Wright, and C. G. Granqvist. "Glazings and Coatings." In *Solar Energy: The State of the Art ISES Position Papers*. Edited by Jeffrey Gordon. London, UK: James & James (Science Publishers) Ltd., 2001, 29-107.
- Janda, Kathryn B. "Buildings Don't use Energy: People do." In *Architecture, Energy and the Occupant's Perspective - Proceedings of the 26th Conference on Passive and Low Energy in Architecture (PLEA)*. Edited by Claude Demers and Andre Potvin. Quebec, Canada: Les Presses de l'Universite Laval, 2009, 22-27.
- Kempton, Willett, and Laura Montgomery. "Folk Quantification of Energy." *Energy* 7, no. 10 (1982): 817-827.
- Kesee, M. *Setting A New Standard - the Zero Energy Home Experience in California*. Orlando, Florida ed. International Solar Energy Society, 2005.
- Kieran, Stephen, and James Timberlake. *Loblolly House : Elements of a New Architecture*. 1st ed. New York: Princeton Architectural Press, 2008.
- Kieran, Stephen, and James Timberlake. *Refabricating Architecture : How Manufacturing Methodologies are Poised to Transform Building Construction*. New York ; London: McGraw-Hill, 2004.

- Leaman, Adrian. "User Needs and Expectations." In *Buildings, Culture and Environment : Informing Local and Global Practices*. Edited by Raymond Cole and Richard Lorch. Oxford, UK ; Malden, MA: Blackwell Pub., 2003, 154-176.
- Lee, Ivan Yun Tong, Christopher Black, and Bartosz Aleksander Lomanowski. *High Performance Facades for Heating and Cooling in Northern Climates*. International High Performance Buildings Conference at Purdue ed. July 12-15 2010.
- Lomanowski, Bartosz Aleksander. *Implementation of Window Shading Models into Dynamic Whole-Building Simulation*. Waterloo, Ont.: University of Waterloo, 2008.
- Mankoff, Jennifer, Deanna Matthews, Susan R. Fussell, and Micheal Johnson. *Leveraging Social Networks to Motivate Individuals to Reduce their Ecological Footprints*. 2007.
- Marcus, Clare Cooper. *House as a Mirror of Self : Exploring the Deeper Meaning of Home*. Berkeley, Calif.: Conari Press, 1995.
- McIntyre, D. A. *Indoor Climate*. London: Applied Science Publishers Ltd., 1980.
- McKibben, Bill. *The Power of the Click*. October 16, 2007.
- Melsop, Susan. "Active Participation in Passive Solar Design: The Poetics of Sustainability." In *Architecture, Energy and the Occupant's Perspective - Proceedings of the 26th Conference on Passive and Low Energy in Architecture (PLEA)*. Edited by Claude Demers and Andre Potvin. Quebec, Canada: Les Presses de l'Universite Laval, 2009, 441-446.
- Morris, A. "Reflections on Social Movement Theory: Criticisms and Proposals." *Contemporary Sociology* 29, no. 3 (2000): 445-454.
- Muise, Kevin, Jin Fan, and Jenny Thai. *North House Graphical User Interface: Industry Review Document*. 2008.
- Negroponte, Nicholas. *Soft Architecture Machines*. Cambridge, Mass: the MIT Press, 1975.
- Negroponte, Nicholas. "Toward a Theory of Architecture Machines." *Journal of Architectural Education (1947-1974)* 23, no. 2 (1969): 9-12.
- Orr, David W. "Architecture as Pedagogy II." *Conservation Biology* 11, no. 3 (1997): 597-600.
- Pask, Gordon. "The Architectural Relevance of Cybernetics." *Architectural Design* September, (1969): 494-496.
- Passy, Florence, and Marco Giugni. "Social Networks and Individual Perceptions: Explaining Differential Participation in Social Movements." *Sociological Forum* 16, no. 1 (2001): 123-153.
- Passy, Florence, and Marco Giugni. "Life-Spheres, Networks, and Sustained Participation in Social Movements: A Phenomenological Approach to Political Commitment." *Sociological Forum* 15, no. 1 (2000): 117-144.
- Piano, Renzo, and Roberto Brignolo. *Renzo Piano : Logbook*. New York: Monacelli Press, 1997.
- Rabeneck, Andrew. "Cybermation: A Useful Dream." *Architectural Design* September, (1969): 497-500.
- RoperASW. *Americans' Low "Energy IQ:" A Risk to our Energy Future*. Washington, D.C.: The National Environmental Education & Training Foundation, 2002.
- Schipper, Lee, Sarita Bartlett, Dianne Hawk, and Edward Vine. "Linking Life-Styles and Energy use: A Matter of Time?" *Annual Review of Energy* 14, (1989): 273-320.
- Seligman, C., J. M. Darley, and L. J. Becker. "Behavioral Approaches to Residential Energy Conservation." *Energy & Buildings* 1, no. 3 (1978): 325-337.
- Sharp, Helen, Yvonne Rogers, and Jenny Preece. *Interaction Design : Beyond Human-Computer Interaction*. 2nd ed. Chichester ; Hoboken, NJ: Wiley, 2007.

- Siero, Frans W., Arnold B. Bakker, Gerda B. Dekker, and Van Den Burg, Marcel T. C. "Changing Organizational Energy Consumption Behaviour through Comparative Feedback." *Journal of Environmental Psychology* 16, no. 3 (1996): 235-246.
- Socolow, Robert. *Saving Energy in the Home : Princeton's Experiments at Twin Rivers*. Cambridge, Mass: Ballinger, 1978.
- Sterk, Tristan d'Estree. "Responsive Architecture: User-Centered Interactions within the Hybridized Model of Control." In *Architecture Co-Laboratory : GameSetandMatch II : On Computer Games, Advanced Geometries, and Digital Technologies*. Edited by Kas Oosterhuis and Lukas Feireiss. Rotterdam: Episode Publishers, 2006, 494-501.
- Sterk, Tristan d'Estree. "Responsive Architecture: User-Centered Interactions within the Hybridized Model of Control." 2010, no. April 29 (2010).
- Stern, Paul C., and Elliot Aronson, eds. *Energy use: The Human Dimension*. New York: W.H. Freeman and Company, 1984.
- Tanizaki, Junichiro. *In Praise of Shadows*. London: J. Cape, 1991.
- Turner, Fred. "Romantic Automatism: Art, Technology, and Collaborative Labor in Cold War America." 7, no. 1 (2008): 5-26.
- USGBC Research Committee. *A National Green Building Research Agenda*. Edited by Martha Bohm. US Green Building Council, Nov 2007, Revised Feb 2008.
- Van Houwelingen, Jeannet H., and W. Fred Van Raaij. "The Effect of Goal-Setting and Daily Electronic Feedback on in-Home Energy use." *Journal of Consumer Research* 16, no. 1 (1989): 98-105.
- Velikov, Kathy, and Lyn Bartram. "North House: Developing Intelligent Building Technology and User Interface in Energy Independent Domestic Environments." In *Architecture, Energy and the Occupant's Perspective - Proceedings of the 26th Conference on Passive and Low Energy in Architecture (PLEA)*. Edited by Claude Demers and Andre Potvin. Quebec, Canada: Les Presses de l'Universite Laval, 2009, 80-85.
- Wilson, Charlie, and Hadi Dowlatabadi. "Models of Decision Making and Residential Energy use." *Annual Review of Environment and Resources* 32, (2007): 169-203.
- Wohlwill, Joachim F. *Behavioral Response and Adaptation to Environmental Stimulation*. University Park, Pa.: College of Human Development, Pennsylvania State University, 1972.
- Woodruff, Allison, Jay Hasbrouck, and Sally Augustin. *A Bright Green Perspective on Sustainable Choices*. Florence, Italy ed. CHI, 2008.
- Zalba, Belén, José M. Marín, Luisa F. Cabeza, and Harald Mehling. "Review on Thermal Energy Storage with Phase Change: Materials, Heat Transfer Analysis and Applications." *Applied Thermal Engineering*, 23, no. 3 (2003): 251-283.



APPENDIX A: Team North Extended Credits

I would like to extend my thanks to all of the following people:

Faculty Team: Geoffrey Thün, Kathy Velikov, David Lieberman, Dr. John Straube, Philip Beesley, Donald McKay, Rick Haldenby, and Dr. Michael Collins.
(University of Waterloo)

Dr. Alan Fung (Ryerson University) Dr. Lyn Bartram, and Dr. Rob Woodbury (Simon Fraser University)

Core Architectural Student Team: Chris Black, Maun Demchenko, Chloe Doesburg, Natalie Jackson, Jen Janzen, and Bradley Paddock.

Core Engineering Student Team: Sebastien Brideau, Brent Crowhurst, Ivan Lee, Bart Lomanowski, Andrew Marston, Toktam Saied, and Humphrey Tse.

Interaction Design Student Team: Rob Mackenzie, Kevin Muise, Johnny Rodgers, Jin Fan, Yin He, Jenny Thai.

Additional Student Team: Fabio Almeida, Wade Brown, Kush Bubbar, Eric Bury, Aya Dembo, Brittany Hanam, Andrew Haydon, Andrea Hunniford, Davis Marques, Lindsey Nette, Raqib Omer Mian, Matt Peddie, David Schellingerhoudt, Sonja Storey-Fleming, Jamie Usas, and Allan Wilson.

MCM 2001 Inc. Fabrication Team: Jack Debski, Gregory Rybak, Sean Baldwin, Witek Jasinski, Mikola Minzak, Krzysztof Banasek, Piotr Dabrowski, Zbigniew Gembora, Adam Golaszewski, Ryszard Goryl, Wladyslaw Iwaniec, Oleg Izvekov, Philip Lesniak, Maks Matuszewski, Pawel Noga, Richard Pelly, Danny Pietrangelo, Krzysztof Plaza, Jan Sawczak, Luke Statkiewicz & Lukasz Szczepanek.

Structural Engineer: Cory Zurell

Electrical Consultation and Installation: Daniel Pelkman (Red Electric), Robin Sanders (Red Electric) & Nicolas Stroeder.

Mechanical Consultation and Installation: Al Davies (Eco-Options Geosolar), Steve Davies (Ecologix Heating Technologies), Aaron Goldwater (Goldwater Solar Services) & Gord Walsh (Slatius Air).

Controls Consultation and Implementation: Chris Brandson (Vertech Solutions) & Reid Blumell (Embedia Technologies)

Mackie Moving Systems: John Fyfe & Fred Taphouse.

Bulthaup Canada Kitchen Systems: Antje Bulthaup & Stefan Sybydlo.