

# Modeling Safety Performance at Grade Crossing using Microscopic Simulation

by

Oi Kei Ng

A thesis  
presented to the University of Waterloo  
in fulfillment of the  
thesis requirement for the degree of  
Master of Applied Science  
in  
Civil Engineering

Waterloo, Ontario, Canada, 2010

© Oi Kei Ng 2010

## **AUTHOR'S DECLARATION**

I hereby declare that I am the sole author of this thesis. This is a true copy of the thesis, including any required final revisions, as accepted by my examiners.

I understand that my thesis may be made electronically available to the public.

## Abstract

The analysis of grade crossing safety has long focused on vehicle-train crashes using statistical models based on crash data. The potential crashes generated by vehicle-vehicle rear-end conflicts have often been ignored. The interaction of different traffic attributes on safety performance of a grade crossing is also not well-understood.

The primary objective of this thesis is to model the causal relationship of vehicle-vehicle interactions by developing the operation logic of gate-equipped grade crossing using a commercially available microscopic simulation package that models human driver behaviors. The simulation-generated vehicle trajectory data allows detail safety performance analysis on vehicle-vehicle interaction over time as they approach the track.

A dual-gate equipped crossing at Kitchener, Ontario is selected as the study area. Initially, logic modifications are made to the simulation package (VISSIM) in order to accurately model the grade crossing segment. A two-step calibration is used in this thesis. Firstly, model input parameters for a signalized intersection from literature are used to model typical car-following behavior along this type of roadway. Secondly, parameters used to model drivers' decision and reaction when approaching crossing is fine tuned through data collection and calibration. After incorporating all the modifications to the simulation package, validation is undertaken by comparing model-generated speed profiles to on-site observed speed profile. The established model is tested for its safety performance sensitivity through varying three traffic attributes in the simulation: (i) percentage of bus, (ii) total traffic volume, (iii) percentage of cars in the center lane of a 2-lane approach. Four safety performance measures were selected.

The overall results indicate that the established model is functional and reliable in modeling grade crossing vehicles interactions at gated crossings. In the absence of a train, vehicles' reduction in speed in the vicinity of a crossing results in traffic flow turbulence that increases the opportunity for high risk rear-end vehicle interactions. The sensitivity test revealed that the spillback behavior of vehicles due to the stopping behaviors of buses increases risk in the upstream section. Also, overloading of vehicles into the network indeed improves safety as the effect of differential speed diminishes. Among the four selected safety performance measures, DRAC seems to reflect problems with rear-end vehicle interactions in the vicinity of a crossing as a function of the traffic attributes considered in this research.

## **Acknowledgements**

My past seven years as an international student at the University of Waterloo has been rewarding, valuable, and joyful. Through the daily greetings with the Canada goose together with a deep breath along my way to school, my soul is filtered and refreshed!

I am heartily thankful to my supervisor, Dr. Frank Saccomanno. His guidance and support has deepened my enthusiasm understanding of the subject. I am constantly inspired by his out-of-the-box thinking. Being under his supervision has been an honor to me.

I am blessed with friendly and cheerful colleagues in the transportation group. Peter Chan, Amir Hosein Ghods have offered their valuable time to assist in the data collection process. It is a pleasure to thank others who helped in various aspect of the thesis, in special, especially to David DOUNG, Yuen Yi Law, Olivia Cheung, Andrew Yu, and Billy Wong.

Lastly, I would like to thank my family for their continued support and understanding throughout my studies at the University. Their love and blessings are my guidance for writing up this new and important chapter of my life.



## **Dedication**

This Thesis is dedicated to my beloved Siu Kuen Law, Kam Hung Ng.

## Table of Contents

AUTHOR'S DECLARATION .....	ii
Abstract .....	iii
Acknowledgements .....	iv
Dedication .....	v
Table of Contents .....	vi
List of Figures .....	viii
List of Tables.....	x
Chapter 1 Introduction .....	1
1.1 Background .....	1
1.2 Objectives and Scope .....	3
1.3 Thesis Layout .....	3
Chapter 2 Grade Crossing Fundamental .....	5
2.1 Type of Grade Crossing .....	5
2.2 Grade Crossing Regulation .....	5
2.3 Traffic Interaction .....	7
2.3.1 Traffic Conflicts and Resultant Crashes.....	8
2.3.2 Train-Vehicle Interaction .....	9
2.3.3 Vehicle - Vehicle Interaction .....	10
Chapter 3 Model Framework .....	12
3.1 Simulation Platforms.....	14
3.1.1 Commercially Available Microscopic Simulation Software vs Self-Developed .....	16
3.1.2 VISSIM .....	18
3.2 Factors Affecting Drivers Behaviors in Grade Crossing.....	23
3.2.1 Speed Reduction.....	25
3.2.2 Time of day .....	30
3.2.3 Nearby Intersection .....	32
3.3 Surrogate Measures of Safety.....	32
3.3.1 Deceleration Rate to Avoid the Crash (DRAC) .....	34
3.3.2 Time to Crash (TTC).....	35
3.3.3 Crash Potential Index (CPI) .....	36
3.3.4 Unsafety .....	37

Chapter 4 VISSIM Modification, Calibration and Validation.....	40
4.1.1 VISSIM Railraod Crossing Demo Crossing.....	40
4.1.2 Required Modification in Gated Crossing.....	40
4.2 Model Parameters Calibration.....	44
4.2.1 Parameters Obtained from Literature.....	44
4.2.2 Fine-Tune Calibration Thru Data Collection.....	46
4.3 Validation.....	51
Chapter 5 Linking DRAC to High Risk Behaviors for Different Traffic Scenarios.....	55
5.1 Traffic Attributes.....	55
5.2 ANOVA Test Layout.....	57
5.3 ANOVA Test Result.....	58
5.4 Case Study – Comparing DRAC to Other Safety Performance Measures.....	63
5.4.1 ANOVA Results.....	66
5.4.2 DRAC VS TTC.....	67
5.4.3 DRAC vs CPI.....	70
5.4.4 DRAC vs UD.....	70
5.4.5 Zonal Effects on Safety Performance Measures.....	71
Chapter 6 Conclusions and Recommendations.....	73
6.1 Recommendation.....	75
Appendix A Transportation Microsimulation Models Theory History and Implementation Snapshot by Model Type.....	76
Appendix B SPSS for Signal Control.....	78
Appendix C Data Extraction Procedures.....	83
References.....	103

## List of Figures

Figure 1 The Safety Pyramid [Source: (Cunto, 2008)] .....	7
Figure 2 Conflict Points and Lines for Regular Intersection [Source: (Gettman & Head, 2003)] .....	9
Figure 3 Example of Rear-end Conflict [Source:(Cunto, 2008)] * .....	10
Figure 4 Rear-end Conflict Line Example for Turning Vehicle in Ordinary Roadway Intersection [Source: (Gettman & Head, 2003)] .....	11
Figure 5 Sociotechnical Model [Source: (Yeh & Multer, 2008)].....	12
Figure 6 Model Framework.....	14
Figure 7 Car Following Model of Wiedemann Thresholds and one vehicle trajectory [Source: (Cunto, 2008)] .....	19
Figure 8 Speed Profiles from 3 Active and 1 Passive (Ontario) Crossings.....	26
Figure 9 Site Location for King Street Crossing * .....	28
Figure 10 Speed Profile from Kitchener Site .....	29
Figure 11 Crash Frequency by Time of Day [Source: (Caird, Creaser, Edwards, & Dewar, 2002)]...	30
Figure 12 Profiles of Vehicle Speed [Source (Ward & Wilde, 1995)].....	31
Figure 13 Profile of Brake Duration [Source (Ward & Wilde, 1995)].....	31
Figure 14 VISSIM representation of train arrival .....	42
Figure 15 Priority Rules Logic in VISSIM .....	44
Figure 16 Calibration/Validation Study Framework by Cunto [Source: (2008)].....	46
Figure 17 Camera Position Source: [Source: (Google, 2010)].....	47
Figure 18 VISSIM Modification for Vehicle Distribution.....	48
Figure 19 VISSIM Modification for Flashing Light and Gate Descend .....	49
Figure 20 Gap Acceptance – Train Departing.....	50
Figure 21 VISSIM Network Setup.....	52
Figure 22 Speed Reduction Profile Comparison between VISSIM and Observation.....	52
Figure 23 Comparison of CPI/veh between Upstream and Crossing area .....	53
Figure 24 Fundamental of Traffic Flow [Source: (Levinson, 2008)].....	55
Figure 25 Main Effects.....	60
Figure 26 Two-Factor Interaction Effect.....	62
Figure 27 Main Effects - DRAC vs Volume and TTC vs Volume .....	68
Figure 28 Main Effects - DRAC vs Buses and TTC vs Buses.....	69
Figure 29 DRAC vs CPI.....	70

Figure 30 DRAC vs Unsafety.....71

## List of Tables

Table 1 Distribution of Reported/Unreported Injuries [Source: (Blincoe, et al., 2002)].....	8
Table 2 VISSIM Car Following Parameters [Sources:(PTV, 2008)].....	21
Table 3 VISSIM Description on Conflict Area Parameters [Source:(PTV, 2008)] .....	23
Table 4 Surrogate Safety Conflict Measures [Source: (Gettman & Head, 2003),(Cunto, 2008)].....	33
Table 5 DRAC Severity Classification .....	35
Table 6 Calibrated Driving Parameters [Sources:(Cunto & Saccomanno, 2008)].....	45
Table 7 Priority Rules Headway Allocation.....	51
Table 8 Traffic Related Factors and Corresponding Levels.....	57
Table 9 Data Layout.....	58
Table 10 ANOVA Results based on DRAC .....	59
Table 11 ANOVA Results based on TTC .....	64
Table 12 ANOVA Results based on CPI .....	65
Table 13 ANOVA Results based on UD.....	66
Table 14 Significant Terms based on Four-way ANOVA under DRAC, TTC, CPI, UD.....	67
Table 15 Zonal Effects on Safety Performance Measures .....	72

# Chapter 1

## Introduction

### 1.1 Background

The Canadian Transportation Safety Board reported that there were 214 grade crossing train-vehicle crashes, 26 fatalities, and 36 serious injuries in 2008 (Canada, 2008). The frequency of these crashes has been compared to the 245 collision/year recorded during 2003-2007. Despite this reduction in frequency, grade crossing crashes are source of concern because of the high personal injury consequences.

Apart from train-vehicle crashes, grade crossing raises special concerns for vehicle-vehicle crashes resulting from traffic disturbances. Reduce speed behaviors are observed in close proximity of the track ((Coleman & Moon, 1999),(Ng & Saccomanno, 2010),(Tenkink & Van der Horst, 1990)) and research further indicate the increased risk of rear-end interactions (Ng & Saccomanno, 2010). This assertion is supported with reference to historical crash experience at grade crossings, where seventy-five percent of reported crashes resulted from rear-end impacts between vehicles notwithstanding the absence of a train (Tenkink & Van der Horst, 1990).

The two most common approaches in analyzing grade crossing safety are statistical models and observational violation studies. Statistical models attempt to correlate train-vehicle crashes with surrounding physical and environmental factors. The data required for statistical analysis include historical crash rate and geometric elements of the roadway. These data do not contain information on vehicles near-misses that did not result in a crash. The methodology of relating crash rates and corresponding geometric characteristic fails to explain the causal relationship that potentially leads to crashes at a given crossing for given geometrical and traffic characteristic. The complex driver's decision and action in response to the changing surrounding environment are not reflected in either data classification or methodology. Hence, statistical models cannot fully model driver behavioral responses to different countermeasures introduced at a given crossing.

Observational violation studies record frequencies of different violation in response to different warning devices. Violations are defined in terms of a videotape sample of drivers in a crossing environment and their failure to observe a set of rules. Violations are and may include: drivers' attempting to go around/under the gate; U-turns near grade crossing for detouring; crossing between trains if there are multiple trains during the same signal phase, etc. A violation study attempts to tailor

countermeasures to driving behavior and can reflect causal factors affecting safety. These studies normally require extensive data collection in order to capture a complete range of drivers behavioral responses in the vicinity of the crossing. The processing of these videos to obtain vehicle and pedestrian violations is quite complex.

The Florida Department of Transportation (FDOT) adopted a violation study approach to investigate the traffic operations at five highway-railroad grade crossing sites. A total of 500 events of interest were videotaped through approximately 7500 two-minute clips (Courage & Kirkpatrick, 2003). In order to classify the type of violation, observers are required to examine each videos clip. Although no actual crash was observed, many undesirable and unsafe movements discussed above were taking place. There is no further vehicle trajectory information to establish the interacting profile when they were approaching each other. Hence, the resulting risk in vehicle-vehicle interaction due to the non-complying vehicles cannot be quantified based on the violation record.

Recent research focuses on microscopic simulation model applications to safety performance analysis at grade crossings. This type of model provides a reliable platform to incorporate complex real-world human driving behaviors into multi-modal traffic flow modeling. The individual representation of vehicles in the traffic network can be used to assess the vehicle-vehicle interactions over time. Hence, it provides a good understanding of the sequence of events occurring before a crash. Unlike statistical models which require multiple years of data, microscopic simulation allows evaluation of countermeasure effectiveness through experimentation before implementing them into the real world.

There are numerous examples of this approach in roadway applications. Robert. et al. (2005) used a commercially available traffic simulation program, VISSIM, to develop an Early Warning System (EWS) for a congested gated crossing with nearby intersections. Aggregate traffic data such as volume and mean speed from simulated traffic are compared to observed traffic at three specific data collection points for parameter calibration. In this paper, the selection of the parameters for calibration was based on engineering judgment. While there is a detail driving behavior setup for the nearby roadway intersection such as “reduce speed area” for turning vehicles, specific driving behavior for approaching the crossing was neglected. The traffic study focused on improving traffic operations at the network level. The safety improvement by the EWS was found to be justified by the long queue backing up the intersections. Tydlacka (2004) also used VISSIM to investigate changes in



average vehicle delay, pedestrian phase cutoffs and vehicle emissions resulting from differences in train operating speeds.

While most of the literature focuses on analyzing safety with regard to vehicle-train interaction, this thesis explores the use of microscopic simulation models to model the causal relationship between vehicle-vehicle interactions approaching a grade crossing. Based on a calibrated and validated model, the affects of traffic attributes and the presence of gated crossing on road safety were evaluated.

## **1.2 Objectives and Scope**

The primary objective of this thesis is to study vehicle to vehicle interaction for grade crossing using a microscopic simulation approach. The following three specific objectives are also addressed in this work.

- Obtain a reliable traffic simulation platform and introduce modifications to model grade crossing environment.
- Obtain accurate values of simulation model input based on videotaped data extracted for a crossing and verify the accuracy of the model results.
- Undertake statistical analysis to study the impacts of selected traffic attributes on vehicle interactions in the vicinity of a grade crossing

The result of this research may provide meaningful insight into the safety evaluation of specific grade crossing countermeasure in terms of vehicle interactions.

## **1.3 Thesis Layout**

This thesis is structured in six chapters.

Chapter 2 presents basic definitions and concepts used in grade crossing operations.

Chapter 3 introduces the microscopic traffic simulation framework for the evaluation of vehicle interactions.

Chapter 4 describes changes in VISSIM logic required for application to grade crossing and the calibration and validation exercise.

Chapter 5 introduces the traffic scenarios for analyzing vehicle interactions and assesses the use of selected safety performances for grade crossing.

Chapter 6 summarizes the major contributions of this research and recommendations for further research.

## Chapter 2

### Grade Crossing Fundamental

This chapter presents some basic terms used in grade crossing operation.

#### 2.1 Type of Grade Crossing

Crossings can be classified into passive crossings and active crossings. Passive crossings use signs and pavement markings as traffic control devices to notify the potential arrival of a train. Motorists, bicyclists, and pedestrians are responsible for identifying the train arrival and taking appropriate actions. Drivers are required to treat a railway crossbuck sign as a yield sign. Active crossings use electronic warning device that are activated by train detection. These active devices notify the drivers that a train is approaching the crossing. These electronic warning devices might include flashing light signals and bells, or automatic gates. In either type of crossings, the status of the crossing is defined as ‘open crossing’ if there is no on-going train activity in the crossing area.

As of 2007, there were 11439 passive crossings and 6011 active crossings in Canada (Transportation Safety Board of Canada, 2008). Among the 6011 active crossings, 3827 are equipped with flashing lights and bells, 2150 with gates, and 34 with other automated warnings (Transportation Safety Board of Canada, 2008). ‘Open Crossing’ is often referred to a state where there is no train movement in the area and the approaching vehicles are undisturbed.

#### 2.2 Grade Crossing Regulation

To successfully simulate vehicle behaviors near grade crossing, all regulations related to vehicle trespassing should clearly be identified. Note that regulation might be slightly different across different jurisdictions. In this research, regulations in Ontario will be employed.

Ontario Highway Safety Act (Ministry of Ontario, 2010) stated the regulation for vehicles approaching the grade crossing as follows:

*Vehicles required to stop at railway crossing signal*

*163. (1) When the driver of a vehicle is approaching a railway crossing at a time when a clearly visible electrical or mechanical signal device or a flagman is giving warning of the approach of a railway train, he or she shall stop the vehicle not less than 5 metres*

*from the nearest rail of the railway and shall not proceed until he or she can do so safely. R.S.O. 1990, c. H.8, s. 163.*

*Stop signs at railway crossings*

*(2) Every driver of a vehicle approaching a stop sign at a railway crossing shall, unless otherwise directed by a flagman, stop the vehicle at the marked stop line or, if none, then not less than five metres from the nearest rail of the railway, and shall not proceed until he or she can do so safely. 2002, c. 18, Sched. P, s. 30.*

*Driving of vehicles under crossing gates prohibited*

*164. No person shall drive a vehicle through, around or under a crossing gate or barrier at a railway crossing while the gate or barrier is closed or is being opened or closed. R.S.O. 1990, c. H.8, s. 164.*

*Public vehicles required to stop at railway crossings*

*(1) The driver of a public vehicle, upon approaching on a highway a railway crossing that is not protected by gates or railway crossing signal lights or marked by a stop sign, unless otherwise directed by a flagman, shall,*

*(a) stop the vehicle not less than 5 metres from the nearest rail of the railway;*

*(b) look in both directions along the railway track;*

*(c) open a door of the vehicle and listen to determine if any train is approaching;*

*(d) when it is safe to do so, cross the railway track in a gear that will not need to be changed while crossing the track; and*

*(e) not change gears while crossing the railway track. 1997, c. 12, s. 13.*

*School buses required to stop*

*(2) The driver of a school bus, within the meaning of section 175, upon approaching on a highway a railway crossing, whether or not it is protected by gates or railway crossing signal lights, unless otherwise directed by a flagman, shall,*

*(a) stop the school bus not less than 5 metres from the nearest rail of the railway;*

- (b) look in both directions along the railway track;
- (c) open a door of the school bus and listen to determine if any train is approaching;
- (d) when it is safe to do so, cross the railway track in a gear that will not need to be changed while crossing the track; and
- (e) not change gears while crossing the railway track. 1997, c. 12, s. 13.

These regulations serve as a basis for modeling the behavior of drivers in the vicinity of a grade crossing.

### 2.3 Traffic Interaction

The level of traffic interactions ranges from undisturbed passages to actual collisions. These frequency and severity of these events are illustrated in Figure 1. Hyden (1987) proposed the concept of a pyramid that comprises of different layers of vehicle interactions where their volumes corresponding to the relative rate of occurrence. The majority of the undisturbed traffic flow is represented by the bottom layer of the pyramid (largest volume). Crashes, on the other hand, are rare randomly events among all traffic interactions and their resulting risks are well recognized. Although the intermediate layers have a higher rate of occurrence than crashes, their risks posed on the traffic stream are often ignored.

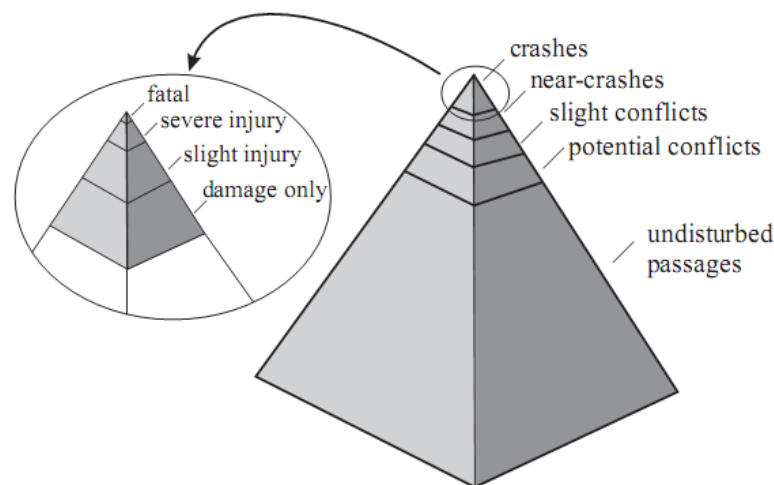

Figure 1 The Safety Pyramid [Source: (Cunto, 2008)]

### 2.3.1 Traffic Conflicts and Resultant Crashes

Crashes refer to the physical contact of vehicles and/or physical surrounding objects (e.g. warning device, light pole) and they are the traditional road safety indicators. Conflicts occur when the first vehicle slows and/or changes direction and places the following vehicle in danger of a rear-end crash.

In North America, only crashes involving personal injury or the property damage are over the set amount regulated are required to report to the police. Unreported crashes and near-misses are often being ignored. According to National Highway Traffic Safety Administration, almost half of the roadway crashes involving only property damage were not reported as shown in Table 1 (Blincoe, et al., 2002). The rate of police reported crashes increases with the severity of the crash.

Table 1 Distribution of Reported/Unreported Injuries [Source: (Blincoe, et al., 2002)]

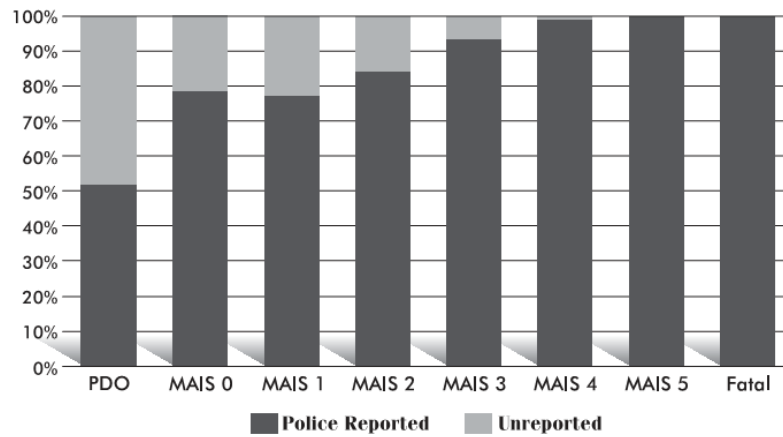

Note: MAIS is the maximum injury severity level experienced by the victim. PDO is property damage only.

In this research, intermediate events including near-misses and traffic conflicts are of main interest. Conflicts can be further divided into conflict points and conflict line (Figure 2). While conflict points refer to a “particular single location in time and space” and conflict lines refer to “conflict events that occur during a range of times and locations (Gettman & Head, 2003)”. In a grade crossing scenario, a conflict point is at the intersecting point of the track and the vehicle roadway and that point is fixed. A conflict line occurs between the vehicle-vehicle on the roadway where there is a series of conflicts taken place.

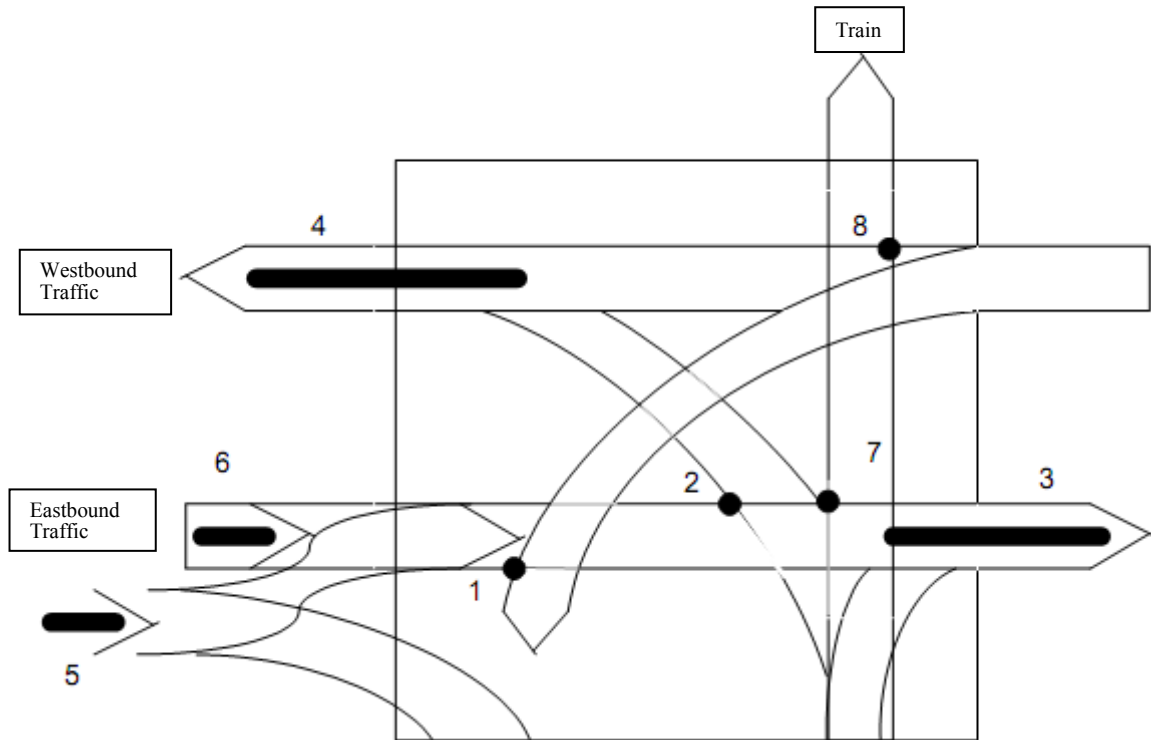

Figure 2 Conflict Points and Lines for Regular Intersection [Source: (Gettman & Head, 2003)]

**Legends:** Crossing Flows (Conflict Point) – notations 1,2,7,8; Merging Crossing Flows (Conflict Line) – notations 3,4; Adjacent Flow (Lane-Changing Conflict Line) – notation 6; Following Flows (Rear-end Conflict Line) – notation 5

### 2.3.2 Train-Vehicle Interaction

The angled train-vehicle interaction is denoted as notation 7 and 8 in Figure 2. Vehicles as defined in this thesis refer to cars, trucks, buses, and other heavy good vehicles. Drivers compliances are the major factors contributing to train-vehicle interactions at active crossing. Vehicle drivers should follow the signal of the electronic warning device (flashing light and gate) and stop at a crossing when the signal is active. Lack of compliance (violation) such as crossing under the gate can result in vehicle-train crashes. In a passive crossing, the crossbuck sign does not notify the driver about the arrival of a train. Since trains are in the higher priority movement, the vehicle driver has to make a decision of when to cross the tracks as if they are approaching a “yield sign” controlled intersection. The smaller the gap accepted by the vehicle driver, the higher the potential for an angled crash.

Unlike regular road intersections where the vehicle in major approach can react with the crossing vehicle in the minor approach, both drivers could react to potential crash by reducing their speed or taking evasive action, a train due to poor deceleration capability has reduced flexibility in speed

control. Hence, most of the train-car crashes resulted in catastrophic consequences involving fatalities.

### 2.3.3 Vehicle - Vehicle Interaction

The rear-end vehicles interaction is denoted as notation 5 in Figure 2. In most cases, speed differential is originated when lead vehicle decelerates to deal with stop sign, amber/red phases of traffic signals or to perform turning maneuvers (Figure 3). The following vehicle is required to brake to avoid the crash when entering the conflict area.

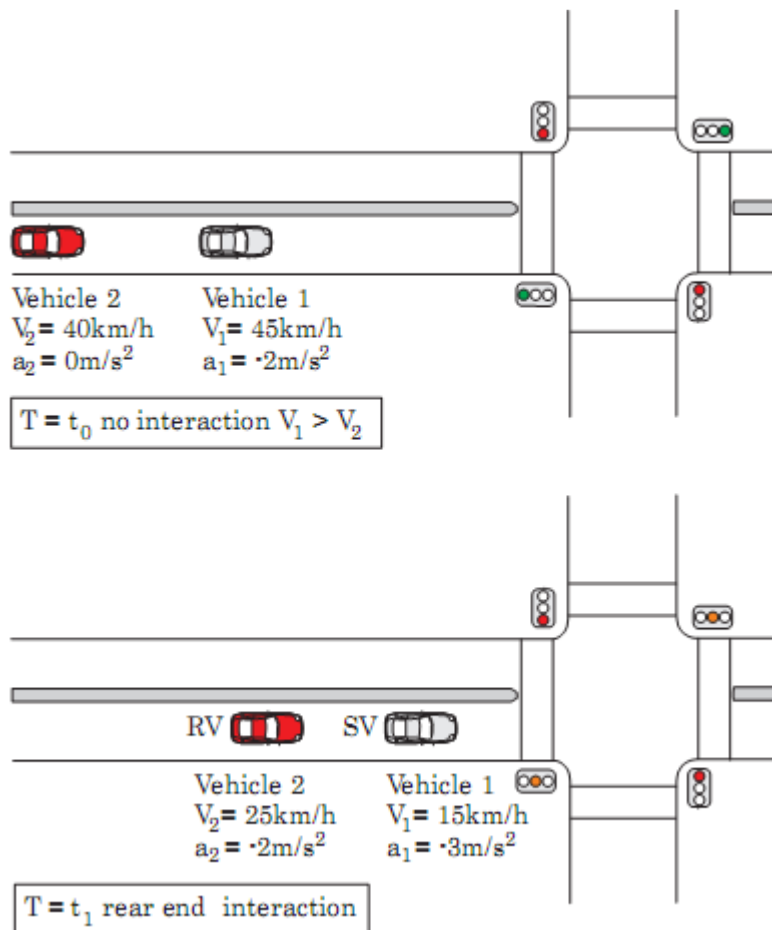

Figure 3 Example of Rear-end Conflict [Source:(Cunto, 2008)] \*

\*RV: immediate following vehicle. SV: stimulus vehicle

Federal Highway Administration (FHWA) (Gettman & Head, 2003) depicts the vehicles trajectories of a rear-end conflict event for a lead vehicle turning from the main street into a minor



street for an ordinary roadway intersection (Figure 4). This representation is also applicable to explain the reduce speed behavior when drivers approaching a grade crossing. At  $t_1$ , the lead vehicle starts to decelerate to cross the track. The following vehicle realizes that a crash might occur at  $t_2$  and begins braking to avoid the crash. The braking indicates the start of a conflict. The location of each vehicle is updated for the next time step ( $t_3$ ). At  $t_4$ , the following vehicle is projected to have reached the location (assuming constant velocity) where the lead vehicle first applies deceleration ( $t_1$ ). The time difference ( $t_4 - t_1$ ) is the post encroachment time. The following vehicle is projected to arrive at the next conflict evaluation point ( $t_5$ ) in the rear-end conflict line (where the lead vehicle was located at time  $t_3$ ). The location of each vehicle is updated again for the next time step ( $t_6$ ). Instead of the lead vehicle turning off the road at a speed close to 0 ( $t_7$ ), it would be the minimum velocity attained by the driver when they cross the track. This minimum velocity is due to the speed reduction behavior of drivers which will be discussed in later chapter. At  $t_8$ , the following vehicle is projected to have reached the point where the lead vehicle was located at time  $t_6$ .

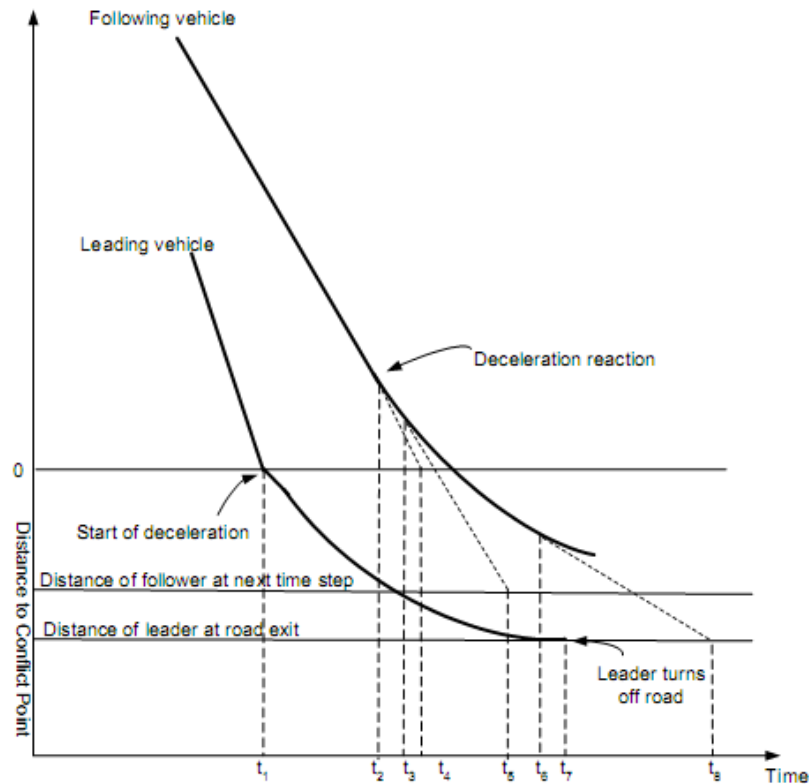

Figure 4 Rear-end Conflict Line Example for Turning Vehicle in Ordinary Roadway Intersection

[Source: (Gettman & Head, 2003)]

## Chapter 3

### Model Framework

A sociotechnical model proposed by Federal Railway Administration examines driver behavior from a system perspective (Figure 5).

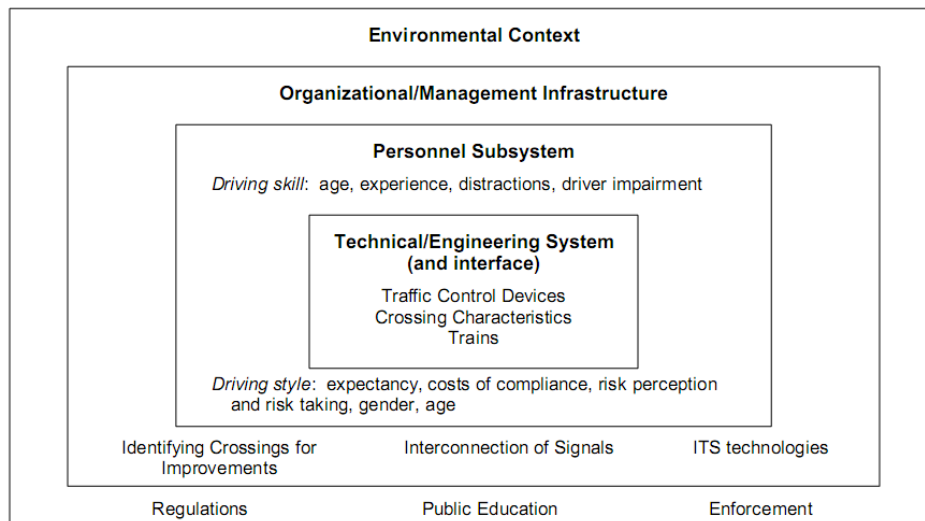

Figure 5 Sociotechnical Model [Source: (Yeh & Multer, 2008)]

In this model, four major interfaces interact with one another: (i) Technical/Engineering interface, (ii) Personnel Subsystem, (iii) Organizational and Management Infrastructure, and (iv) Environmental Context.

#### Technical/Engineering Subsystem (or Interface)

The Technical/Engineering Interface reflects the design of grade crossing environment. Components, such as crossing type, traffic volume, traffic speed distribution, pavement condition, etc, have direct influence on drivers' reaction (personnel subsystem) to the crossing. For example, drivers have to encounter a physical barrier in a gated crossing comparing to flashing-light only crossing and they are forced to come to a stop.

#### Personnel Subsystem

In Personnel subsystem, the two main components are driving style and driving skills. Drivers' perception and aggressiveness shapes their driving style. Risk taking drivers approaching a grade crossing will cross the track even if they hear the bells (indication of train arrival) are ringing. The

differences in demographic characteristic among the sample drivers are reflected in driving behavior. Elderly drivers drive slower than younger drivers and they tend to avoid driving at night time, carry less passengers, etc (Chu, 1994). The behavioral variation among drivers in a traffic stream has to be identified to tailor specific countermeasures.

#### Organization/Management Infrastructure

In Organization/Management Infrastructure level, the goal is to identify locations which need improvements and determine the appropriate countermeasures to enhance safety. Safety performance measures play an important role in quantifying the risk of a specific grade crossing environment. It can also be used in countermeasures evaluations. Up-to-date technology was considered in deciding approximate countermeasure. For example, preemption in connecting signals with nearby intersections is applied to minimizing the risk resulted from potential vehicles spilled back from downstream intersections.

#### Environmental Context

The outer layer of the sociotechnical model is determined from a society perspective which comprises of government policy, politics, and public pressure. Train horn ban is an example where social pressure outweighs the technical implication (Yeh & Multer, 2008). Train horns have been used to alert drivers about the arrival of a train to a grade crossing. Unfortunately, in some jurisdictions continuous complaints have been received from the nearby neighborhood about the noise disturbance. Politicians are subjected to enormous public pressure to rectify the issue. Extra cost has been spent to upgrade the existing passive crossing to active crossing in order to support the establishment of Quiet Zones where train horns have been banned.

This sociotechnical model forms the basis for establishing the microscopic simulation model framework applied to grade crossing (Figure 6). In this research, the dual-gate crossing at Kitchener, Ontario described in Section 3.2.1 is used as a network basis in simulation. In order to model a grade crossing, model modifications have to be identified. Once this technical system is established, calibration and validation of driver behavioral parameters are undertaken (personnel subsystem). Then, simulation can be run and vehicles are generated in the program corresponding to the predefined decision making modules inside the program. Safety performance analysis can be estimated using these vehicles trajectory data generated from a simulation. Lastly, various scenarios can be implemented into the network to identify the sensitivity of various factors interested.

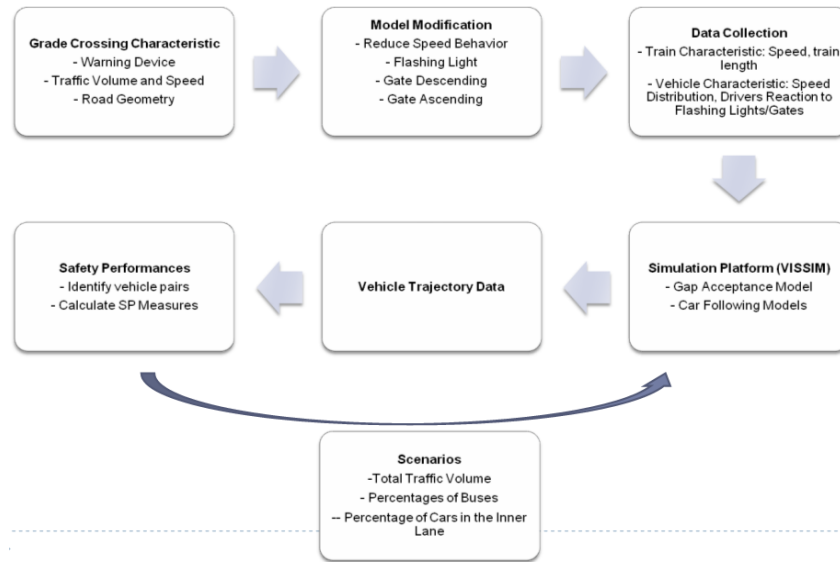

Figure 6 Model Framework

In this chapter, the reasoning for selecting commercial available simulation platform as an analysis tool and the description of the selected simulation platform will be discussed. Then, factors affecting drivers' behaviors in grade crossing simulation will be identified. Finally, the surrogate measures of safety used in quantifying the rear-end vehicles interactions are introduced.

### 3.1 Simulation Platforms

There are different modules in a simulation platform that control vehicles movements and their interactions in the traffic network. Each module contains specific algorithm and user-define parameters that determine traffic operation such as transit, pedestrian, signal control, and driver behavior. The FHWA (Federal Highway Administration, 2004) categorizes various driver behavior models into three groups based on their functionality, namely strategic, tactical, and operational (Appendix A). In this thesis, the investigation focuses on driving behavior as it has the most direct influence on the vehicle-vehicle interaction. Lane changing model and route choice model will not be used in this research. Hence, only the two operational models, gap acceptance and car following models will be incorporated into the simulation.

## Operational – Gap Acceptance Models

According to Highway Capacity Manual (1985), critical gap is defined as “the median time headway between two successive vehicles in the major street traffic stream that is accepted by drivers who must cross and/or merge with the major street flow”. Gap acceptance models attempt to describe driver behavior in the merging process including crossing or turning movement at roadway intersection. In a grade crossing scenario, the gap acceptance represents the vehicle crossing behavior at a passive grade crossing. Vehicle crossing under the gate in an active grade crossing is another example of gap acceptance.

As shown in Appendix A, the development of gap acceptance model has three directions which are deterministic, probabilistic, and hybrid. Deterministic gap acceptance model uses a unique value to represent the critical gap. Driver would only accept a gap if the observed gap is greater than the critical gap (threshold). The disadvantage of this approach is the lack of driving behavior variation. Probabilistic gap acceptance, on the other hand, uses a gap distribution to generate the critical gap. This method ensures the diversity of driving behavior among the traffic stream is being captured. Various distribution forms such as logit, log-normal, etc are developed (Appendix A).

Hybrid Neuro Network/Fuzzy Logic model has been introduced in the early 21<sup>st</sup> century to incorporate driving behavior into rule-based logic specifically for regular roadway intersection. Gap acceptance is optimized by taking into considering the different types of input information such as type of maneuver at the intersection (left turn vs right turn), delay experiencing, and traffic condition ((Pant, 1994),(Rossi & Meneguzzo, 2009),(Lyons, Hunt, & McLeod, 2001)). The output of the process is the gap acceptance prediction presented in 0 or 1. Sample data will be fed into the computational program for recognizing the hidden rules in the learning process. The model is then validated using a separate set of data sample.

## Operational – Car Following Models

Car-Following theories attempts to model the vehicle interactions in the traffic stream via various mathematical models. The three most common approaches are stimulus-response, desire measure, and psycho physical. In a stimulus-response relationship, drivers respond to the stimulus according to the following relation:

$$Response = \alpha Stimulus \quad [3-1]$$

Where

$\alpha$  = proportionality factor which represent drivers sensitivity to the stimulus

Stimulus = factors such as speed, headway, acceleration, vehicle performance, etc.

Response = acceleration or deceleration of the reacting vehicle

The fundamental stimulus-response relationship is based on a linear relationship assumption. Researchers further integrated the model through different perspectives in order to better describe the actual driving behavior, for example, extending from linear to non-linear models, considering two regime models (congested and not congested), etc (Appendix A).

The second approach of car-following theory development is based on desired measure. Pipes (1953) suggested that safe-following distance (space headway) should be directly proportional to speed. Later development includes using different desired measures such as optimal velocity (Newell, 1961); and incorporating different integrating factors (Gipps, 1981), etc.

A psycho-physical car-following model attempts to replicate human perception with the change in physical stimuli. For example, drivers only perceive a speed differential in relation to the lead vehicle only when the rate of visual change in size of lead vehicle exceeds a perception threshold. This is known as perceptual threshold of visual expansion rate. In Widemann's model (PTV, 2008), the change in traffic attributes such as speed and headway, categorize vehicles into different states and drivers will react accordingly within these states.

In this research, a gap acceptance model that can demonstrate a variety of driving characteristic is preferred. Also, a psycho-physical car following is preferred over others as the influence of driver behaviors are of interest. These models form the framework of a simulation platform. In the next section, the selection of a simulation platform will be discussed.

### **3.1.1 Commercially Available Microscopic Simulation Software vs Self-Developed**

There are two options available when seeking a simulation platform: (i) Using an existing commercially available simulation packages, or (ii) Developing a new simulation package. An overview of the two options is presented in this section.

The development of commercially available microscopic simulation platform has been continuing over the past decade. Original applications focused on multi-model traffic planning and operation analysis. Effort has been spent on developing algorithms to model various traffic environments such as interchanges, roundabouts, transit priority, signalized and unsignalized intersection. Driving

behavior modules have also been added to better reflect traffic pattern and enhance the accuracy of traffic measures output. The movements of vehicles in the traffic network at each time stamp are represented by a pre-set of rules. User-friendly interfaces ease the network setup and model parameters input. Unfortunately, there is no built in function in commercial packages for modeling gates and flashing lights in grade crossing. Model modification is required. The most commonly used simulation packages are AIMSUN, ARTEMIS, CORSIM, Paramics, VISSIM, etc. Each of these programs has employed different driver behaviors models and are listed in Appendix A.

To tackle the network setup problem, researchers attempted to develop their own program to model grade crossing. In 1997, Coleman and Moon (1997) attempted to model both vehicle-vehicle and vehicle-train interactions at dual-gate HRGC by developing their own simulation platform language SLAM II using FORTRAN statements. Driver types are divided into normal (car), aggressive (car), older (car), truck, school bus, and HAZMAT (hazardous material). Modeling of variation in behavior is accomplished through assigning distributions of vehicle speed, acceleration/deceleration to different types of drivers. Vehicle stopping decisions at a flashing signal in grade crossing is modeled as if the dilemma zone is an amber interval of regular interaction. Vehicle stopping behavior is based on the amber and all-red (inter-green) interval and the concept of ‘dilemma’ used in signalized intersections. The safety performance is presented in terms of the frequency of safe stops, unsafe stops, and number of vehicles proceeds through the track during train arrival.

There are limitations in the above mentioned research.

1) There are insufficient details in their driving behavior models. For example, under a 2-lane approach, the lane selection would affect driving behaviors during gate descending. Drivers from the center lane are expected to have more time to clear the track as the gate descends from the shoulder lane to the center lane.

2) The program is incapable of considering the traffic network as a whole. This simulation analyzes one grade crossing at a time and it is not able to include nearby intersections and analyze safety on a network basis.

Commercially available simulation packages are preferred over self-develop program in this research for the following reasons.

The work of implementing lane changing, car following, and gap acceptance in self-developed program is repetitive. Since these fundamental driving behaviors have been tested and implemented

into the road sector, these modules are ready to use. The market microscopic simulation platform is well-grown that users can easily find one that suits their research purpose.

In the example of Coleman and Moon (1997), the final product of the program is not applicable in evaluating a traffic system. In order to consider the impact of a nearby intersection to a grade crossing, the entire program logic has to be rewritten. In commercially developed software, program logic for other system component are mature and ready to use, e.g. intersections, highway, and traffic control. Hence, once logic modification has been developed for modeling a specific type of grade crossing, it can be added to the traffic network.

### **3.1.2 VISSIM**

A commercial traffic simulation program, VISSIM, is used in this research to simulate the traffic interaction at grade crossing. The major advantage of VISSIM over other programs is its flexibility in manipulating the built-in features such that users can easily remodel the logic to suit their needs. The details of the model modification are discussed in Chapter 4. The traffic control language, Vehicular Actuated Programming (VAP), integrated in VISSIM enables logic modification possibility which better model a grade crossing environment. The sophisticated vehicle behavior modeling captured the drivers' decision and reactions to different traffic scenarios. A small time step of 0.1 second provides a high resolution of vehicles trajectories which provide detail vehicle interactions. The VISSIM platform also allows an expandable collection of different vehicle types and user-defined changes of driving behavior (e.g. desired speed distribution, acceleration and car-following behavior) to better represent site-specific characters.

#### **3.1.2.1 VISSIM Car Following Model**

VISSIM implements the Wiedemann's car following model (CFM) developed in 1974 and 1991 (Appendix A). Wiedemann categorized all drivers into four modes, which are: (i) un-influenced driving, (ii) approaching, (iii) following, and (iv) braking. While the psycho-physical model governs longitudinal vehicle movement, a rule based algorithm determines the lateral movement.



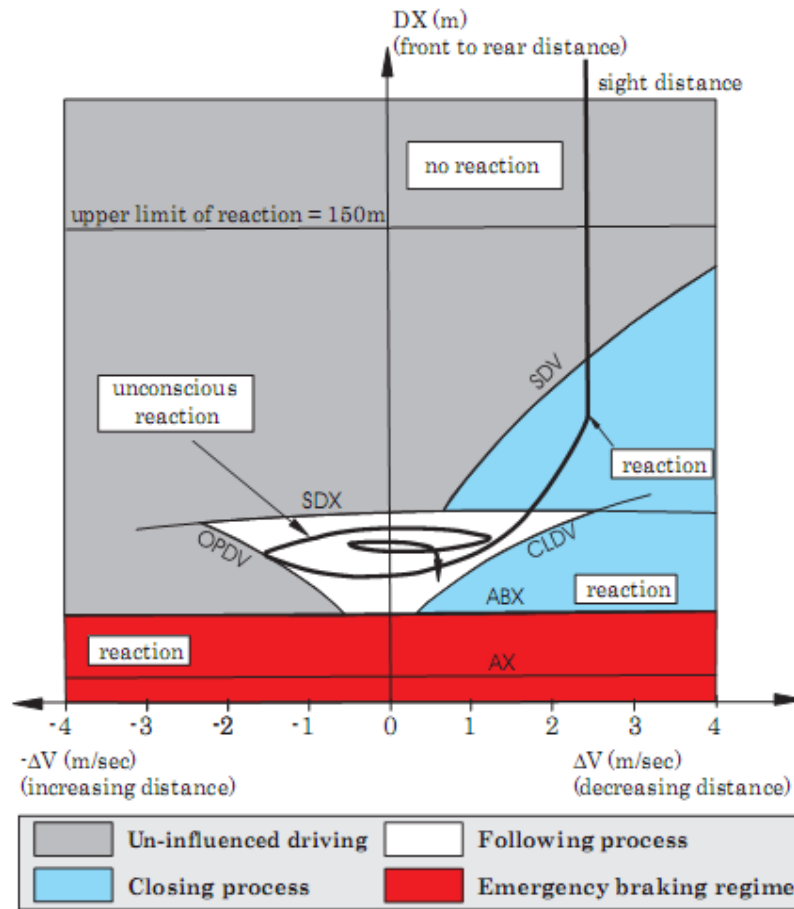

Figure 7 Car Following Model of Wiedemann Thresholds and one vehicle trajectory [Source: (Cunto, 2008)]

#### Un-influenced Driving (grey area)

Drivers travel at predefined desired speed in free driving mode where there is no interruption in the traffic (either no lead vehicle or headway is less than 150 m). For headway distances of less than 150 meters, the following driver remains in free driving mode until he perceives the lead vehicle is at a slower speed. This perception threshold of differential speed at long distance (SDV) is directly proportional to differential speed ( $\Delta V$ ).

#### Closing Driving (blue area)

If there is a lead vehicle and the SDV threshold is exceeded, the driver will be categorized as in closing driving mode. In reaction to the slow vehicle ahead, the following driver will apply

deceleration until he reaches his desired safety distance (ABX). Then, the following driver will attempt to maintain a consistent headway ( $\Delta V = 0$ ).

#### Following (white area)

The vehicle is transferred from Closing mode to Following mode when the headway is smaller than the maximum following distance threshold (SDX) where  $DX < SDX$ . The SDX value is about 1.5-2.5 times the ABX value. In this mode, the following vehicle maintains same headway with the lead vehicle by applying certain acceleration and deceleration. Due to imperfect throttle control and estimation of differential speed, there is  $0.2 \text{ m/s}^2$  oscillation in acceleration and deceleration. OPDV is the threshold for the following driver perceives his speed is less than the lead vehicle and starts acceleration. CLDV is another threshold representing the additional deceleration at short and decreasing distance.

#### Emergency (red area)

There are several conditions that can trigger the Emergency mode. (1) The transition from Closing to Emergency happens when the headway dropped below desired safety distance ABX. (2) The transition from Following to Emergency happens when the sudden deceleration of lead vehicle causes  $DV > CLDV$  and  $DX < ABX$ . In the emergency mode, driver has to undertake action to avoid a crash and reach the minimum desired distance for standing vehicles (AX).

Table 2 lists the 15 available car following input parameters and their descriptions for car-following model extracted from VISSIM manual (PTV, 2008).

Table 2 VISSIM Car Following Parameters [Sources:(PTV, 2008)]

Parameters	Description
CC0	The desired distance between stopped cars. It has no variation.
CC1	The time (in s) that a driver wants to keep. The higher the value, the more cautious the driver is.
CC2	The ‘following’ variation restricts the longitudinal oscillation or how much more distance than the desired safety distance a driver allows before he intentionally moves closer to the car in front.
CC3	Threshold for entering ‘following’ controls the start of the deceleration process.
CC4	Following threshold for controlling negative speed differences
CC5	Following threshold for controlling positive speed difference
CC6	Influence of distance on speed oscillation while in following process
CC7	Actual acceleration during the oscillation
CC8	Desired acceleration when starting from standstill
CC9	Desired acceleration at 80 km/hr
Look ahead distance	The distance that a vehicle can see forward in order to react to other vehicles either in front or to the side of it (within the same link)
Number of observed vehicle	Sensitivity describing vehicle’s prediction on other vehicles’ movements.
Look Back Distance	The distance that a vehicle can see backwards in order to react to other vehicles behind (within the same link)
Temporary lack of attention (Duration and Probability)	Vehicle will not react to a preceding vehicle for a certain amount of time

### 3.1.2.2 VISSIM Gap Acceptance Model

VISSIM uses a deterministic gap acceptance model for vehicle interactions. Users define the critical gap and the specific conflict location. There are two modules in VISSIM to replicate gap acceptance maneuvers, namely, priority rules and conflict area.

A priority rule consists of one stop line and one or more conflict markers that are associated with the stop line. The placements of these attributes are user-defined. The virtual stop marker (stop line) indicates the location where approaching vehicle will wait for the gap. The conflict marker placed on the higher priority approach contains information regarding the critical gap time and the minimum headway. The following two conditions must be satisfied before releasing the approaching vehicle.

- (1) The available gap must be greater than the user defined critical gap
- (2) No vehicle should be present predefined headway ( $X_0 + h$ ). \* $X_0$  start of measurement;  $h$  - minimum headway

A conflict area is an overlapping area between two links (major and minor roadways) automatically detected by VISSIM. VISSIM calculates the deceleration/acceleration profile for the approaching vehicle in the lower priority road based on the available gap for each 0.1 second interval. There are several parameters governing vehicle movement in the conflicts situations (Table 3). This module is added to VISSIM in its version 4.3 and subsequent version. The major improvement is the ability to replicate potential deceleration for vehicle in the major stream. Under priority rules, vehicles on the main street are not reacting to the approaching vehicle (lower priority). However, in conflict area, vehicles are allowed to make protective action (e.g. deceleration) to avoid a crash.

In this research, train is assumed to travel on constant velocity. The assumption that the train is reacting to the vehicles in a conflict area is impracticable in this study as train has limited deceleration capabilities. Hence, priority rules are preferred over conflict area in replicating the gap acceptance behavior. Behavior variation in traffic stream can be achieved by using different vehicle types. The variation within the same vehicle types can be done by placing multiple priority rules such that aggressive drivers and cautious drivers are assigned to different critical gap time. The details of the setup will be discussed in next chapter.

Once the simulation platform has been selected, factors affecting driver behaviors in grade crossing have to be determined as they will affect the network setup and the values or parameters inputs.

### 3.2 Factors Affecting Drivers Behaviors in Grade Crossing

Factors that have influence on grade crossing safety should be considered in a simulation platform. The previously introduced sociotechnical model (Figure 5) has been used (Yeh & Multer, 2008) to examine driver behavior at grade crossings through a system perspective. The simulation model is able to capture the characteristics in personnel subsystem and technical/engineering system through logic modification inside the program. Since vehicle to vehicle interactions are the primary focus of this thesis, factors relating to identification of train arrival, such as lateral sight distance, train speed, warning times, will not be considered. The following subsection summarizes the important factors from the literature that should be considered when undertaking a safety analysis for a grade crossing.

Table 3 VISSIM Description on Conflict Area Parameters [Source:(PTV, 2008)]

Parameter	Description
Visibility	Maximum distance from where an approaching vehicle can see vehicles on the other link. As long as a vehicle on the minor road is further away from the conflict area it plans to stop in front of the conflict area. Caution: Values below 1 m can cause a vehicle to stop forever because it may not come close enough to the conflict area due to the driving behavior setting
Minimum Gap	Minimum gap in seconds between the rear end of a vehicle on the main road and the front end of a vehicle on the minor road, i.e. the proposed time elapsed since the vehicle with right of way has left the conflict area before the yielding vehicle enters it.
Rear Gap	Minimum gap in seconds between the rear end of a vehicle on the minor road and the front end of a vehicle on the main road, i.e. the time that a yielding vehicle must provide after it has left the conflict area before a vehicle with right of way enters the conflict area.

Safety distance factor	This value is multiplied with the normal desired safety distance of a vehicle on the main road to determine the minimum headway that a vehicle from the minor road must provide at the moment when it is completely inside the merging conflict area. (Used only for merging conflicts.)
Additional stop distance	Distance that moves the (imaginary) stop line upstream of the conflict area. As a consequence, yielding vehicles stop further away from the conflict and thus also need to travel a longer distance until they pass the conflict area. (relevant for the minor road only)
Observe adjacent lanes	If this option is active, the incoming vehicles on the minor road pay attention to the vehicles on the prioritized link which are going to change to the conflicting lane. Please note: This option will reduce the simulation speed.
Anticipate routes	This factor describes the percentage of incoming vehicles on the minor road which consider the routes of the approaching vehicles on the main road (when calculating the gaps).
Avoid blocking	The percentage of vehicles on the main road which will not enter the crossing conflict area as long as they cannot expect to clear it immediately. While these vehicles on the major road are waiting for more room downstream of the conflict area the vehicles on the minor road can cross the conflict area. A prioritized vehicle in the selected percentage checks the room downstream of the crossing conflict area. If this is less than the vehicle's length plus 0.5 m and if the blocking vehicle is slower than 5 m/s and slower than 75% of its desired speed (or if the obstacle is a red signal head), the prioritized vehicle will not enter the conflict area.

### 3.2.1 Speed Reduction

Current literature has suggested drivers tend to reduce their speeds in the vicinity of a crossing to avoid the impact of an uneven pavement at the track and/or the uncertainty of a train being presence ((Tenkink & Van der Horst, 1990),(Coleman & Moon, 1999),(Ward & Wilde, 1996)). Several important factors need to be determined: the magnitude of the speed reduction, distance from track at which this reduction is initiated, the effect of distance on speed reduction, and average deceleration rates.

Four recent observational studies have reported significant speed reductions for vehicles approaching a crossing at different distances from the track (Figure 8). This reduction takes place despite the absence of a train at the crossing. Tenkink and Van der Horst (1990) studied the speed profiles of approaching road vehicles at two rural crossings equipped with flashing lights (red with train, white without train) in the Netherlands. Coleman and Moon (1999) investigated speed profiles at two grade crossings both situated along the Chicago-St. Louis high-speed rail corridor in the United States (U.S.). Ward and Wilde (1996) investigated speed profiles for vehicles approaching a rural 2-lane passive crossing (cross-buck only) in Central Ontario.

In the Tenkink and Van der Horst (1990) study, drivers were permitted to traverse the tracks without slowing down under a white signal, whereas under a red signal drivers were required to come to a full stop. The two-phase signal (red and white) in this study added an additional level of control over conventional single phase signals (red-only), in that drivers were formally informed that no train was approaching the crossing. In this study, the site was videotaped from 8 am to 6 pm over seven days. Speed and deceleration profiles were estimated in approximately 5 m increments beginning at a distance of 70 m from the track.

In the Coleman and Moon (1999) study, speed profiles were obtained from vehicle samples videotaped at two dual gate-equipped sites. The Hartford site is an industrial crossing with a posted speed limit of 45 mph (72 km/hr). The McLean site along US136 has a posted speed limit of 40 mph (64 km/hr). In these studies, pavement markings were used as location reference points, and the videotape profiles were coded into three zones with respect to distance from the track: Zone A: distance 93 to 31 m (at the McLean Site) and 77 to 31 m (at the Hartford Site), Zone B: distance 31 m to entry barrier, and Zone C: distance 28 m between entry to exit barriers on either side of the track.

In the Ward and Wilde (1996) study, two passive crossings were investigated with a posted road speed limit of 60 km/hr. Sonar units were stationed along the roadside at incremental distance varying

in lengths from 5 m to 25 m, and speeds were measured from soundings. The resultant average speeds were reported for seven zones with respect to distance from the track.

The mean speed profiles obtained from the above four studies are illustrated in Figure 8, along with their reported corresponding  $\pm 1$  SD confidence interval. For the Ward and Wilde (1996) study, only mean values were reported. The  $\pm 1$  SD confidence interval provides an indication of the range of speeds observed at the various reference points (distance) for the entire sample of vehicles in each study. In general, vehicle-specific speeds encompass a range of values between  $\pm 6$  m/s over the entire approach segment, and this range does not appear to be affected by distance to the track.

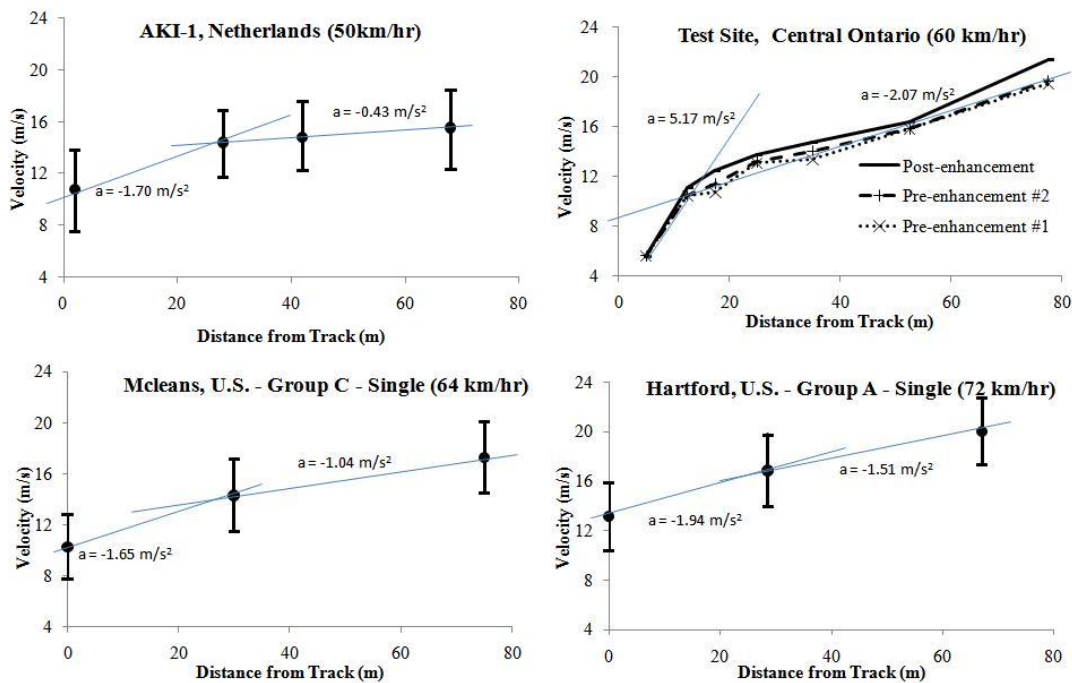

Figure 8 Speed Profiles from 3 Active and 1 Passive (Ontario) Crossings

Studies from the active crossings (excluding Ward and Wilde (1996)) are consistent in suggesting that in the absence of trains, road vehicles on average will reduce their speeds with distance to the track. All studies report a similar track crossing speed of between 10 and 13 m/s (approximately 35 and 50 km/hr). These studies seem to be inconsistent as to the maximum distance from the track at which speed reduction is initiated. Coleman and Moon (1999) suggested a maximum distance of about 70 m (similar to Ward and Wilde (1996)), whereas Tenkink and Van der Horst (1990) suggested that the initial speed reduction only became significant at a distance of about 30 m from the



track. Prior to the 30 m reference point, vehicle deceleration rates were found to be low such that vehicles were considered as maintaining a uniform approach speed. The resultant average speed profiles obtained from these studies are illustrated in Figure 8, with means, +/- 1 SD and corresponding deceleration rates at various distances from the track.

### 1. Magnitude of Speed Reduction

There is a significant difference between active and passive grade crossings in terms of the magnitude of speed reduction. The average speed recorded at the track was found in the above studies to be about 35 km/hr for all active grade crossings. For the passive crossing considered by Ward and Wilde (1996) with a posted speed limit of 60 km/hr, a 70% speed reduction was observed from 19 m/s (68 km/hr) to 5 m/s (20 km/hr). For the active crossings with posted speed limits of 50 km/hr, 64 km/hr, and 72 km/hr, the percentage reduction in speed was found to be 30.6%, 48.1%, and 40.7%, respectively.

Since the magnitude of speed reduction is greater for roads with higher posted speed limits, we would expect a higher deceleration rate at these crossings with a corresponding higher number of rear-end vehicle interactions. In this paper, this will be investigated further with regard to distance-related average deceleration rates.

### 2. Zonal Segmentation of Speed Reduction

In general, studies documented in the literature found that there is a gradual speed reduction in the upstream segment (Zone 1: more distance segment from the track) followed by a more abrupt higher speed reduction in the downstream segment (Zone 2: nearer to the track).

For the passive crossing investigated by Ward and Wilde (1996), an average deceleration rate of  $2.1 \text{ m/s}^2$  ( $7 \text{ km/hr}^2$ ) estimated for Zone 1 is followed by a considerably higher deceleration rate of  $5.2 \text{ m/s}^2$  ( $18 \text{ km/hr}^2$ ) in Zone 2. Differences in the average deceleration rates were found to be especially abrupt at a distance of about 10 to 15 m from the track. The majority of the speed reductions observed by Coleman and Moon (1999) was also found to take place within the first 15 m of the track, with an average rate of  $1.8 \text{ m/s}^2$  ( $7.2 \text{ km/hr}^2$ ). If we assume that the initial reduction in speed was initiated at about 60 m from the track, the deceleration rate in Zone 1 would vary between  $1.0 \text{ m/s}^2$  ( $3.6 \text{ km/hr}^2$ ) and  $1.5 \text{ m/s}^2$  ( $5.4 \text{ km/hr}^2$ ).

For a posted speed of 50 km/hr, Tenkink and Van der Horst (1990) found that the majority of the speed reduction took place within the first 30 m from the track, with a rate of  $1.7 \text{ m/s}^2$  ( $6.1 \text{ km/hr}^2$ ).

This study noted that a more gradual reduction in speed took place in the upstream segment (Zone 1) with a rate of about  $0.4 \text{ m/s}^2$  ( $1.5 \text{ km/hr}^2$ ). A more gradual reduction in speed was observed at Zone 1, which is consistent with the results reported by Coleman and Moon (1999) for the U.S. crossings.

A speed reduction study conducted in 2009 for an open crossing (no train arrival) and this is presented in this thesis (Ng & Saccomanno, 2010). The site selected for speed analysis consists of a single gate-equipped crossing intersecting a four lane approach road (King Street) in Kitchener, Ontario (as illustrated in Figure 9). The background photo was taken in 2006 whereas pavement markings have been slightly modified to correspond to their current location for the data collection exercise. The King Street crossing was selected because of its relative isolation from other nearby intersections and driveways. The posted speed limit on King Street at this site is 50 km/hr. Although a significant number of passenger and freight train use this crossing, the data collected in this study were obtained when no train was present at the crossing.

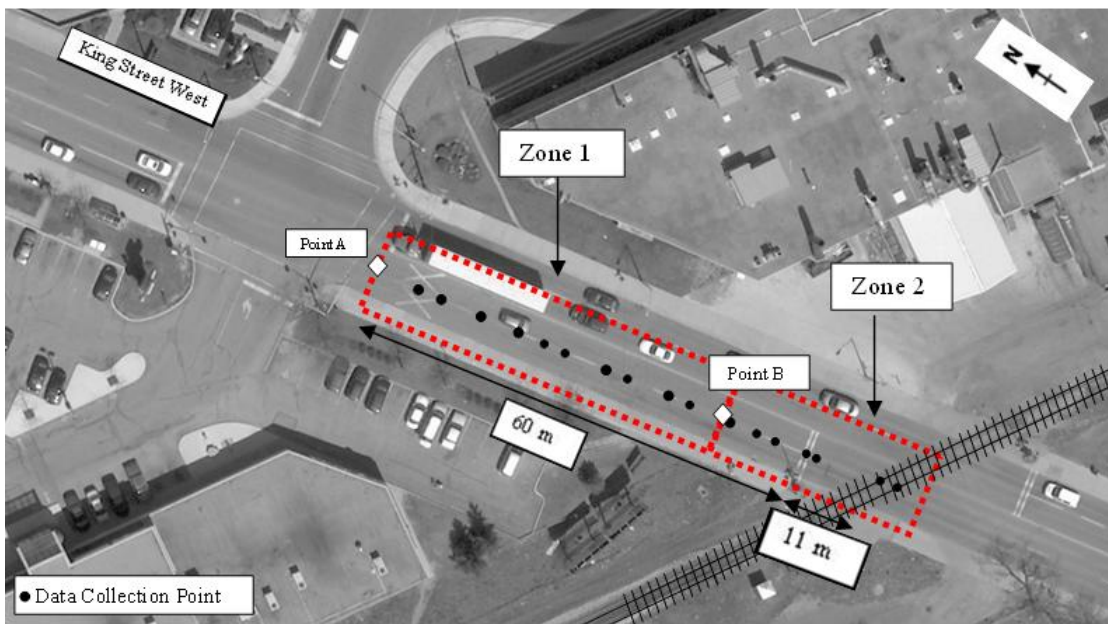

Figure 9 Site Location for King Street Crossing \*

\*background extracted from City of Kitchener Interactive Online Internet Mapping

The data collection consisted of a 15-minute videotaping of traffic in the southbound direction along King Street. The speeds of vehicles in the northbound direction were assumed to be affected by discharging vehicles from a major downstream signalized intersection. In our data collection, vehicles entering the approach segment from side streets and driveways were ignored, as were adjacent

vehicles in the sequence. Only “uninterrupted” vehicles traversing point A in Figure 9 were sampled. Since buses are required to come to a full stop at the crossing, they were also removed from the vehicle sample. The speed and progression of 53 vehicles (autos) were obtained in this exercise.

The southbound approach road was divided into two zones with regard to distance from the track: Zone 1 between Point A and Point B (about 20 m from the track), and Zone 2 between Point B and the track itself. Fixed objects such as lane dividers and tracks were used as reference points for estimating the distances. During video playback, time was recorded per vehicle on a frame by frame basis as each vehicle crosses a given reference point. Based on the time progression of vehicles in Zones 1 and 2, speed profiles were obtained at all reference points.

The speed profiles obtained from the King Street crossing are illustrated in Figure 10, with corresponding means and +/- 1 SD confidence intervals. There are 11 reference points along the approach road in Zone 1 (with a length of 40 m) and 5 reference points in Zone 2 (with a length of 20 m).

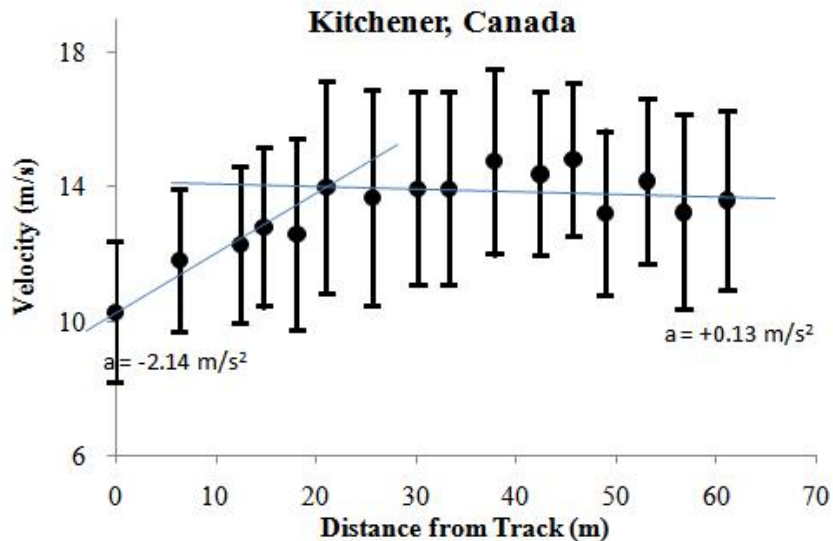

Figure 10 Speed Profile from Kitchener Site

Consistent with driving behavior as inferred from previous studies, the speed profile from the King Street crossing demonstrates a 2-zone transition. The change of speed in all active crossings is mild at the upstream segment starting at about 60 m from the crossing and become more abrupt at the 20 to 30 m segment nearer to the track. While on average deceleration rates are below the comfortable thresholds, a safety concern is raised for individual vehicle pairs (following/lead vehicles) when the

worst case speed reduction profiles are considered. In this case, deceleration rates in Zone 2 can be as much as five times higher than the comfortable threshold. This poses some significant safety concerns at level crossings, despite the absence of a train.

### 3.2.2 Time of day

Crash frequency data (Figure 11) from Canadian grade crossing (between 1983 and 2001) indicated that about 40% of all crashes occurred between 9:31 a.m. and 3:30 p.m. (Caird, Creaser, Edwards, & Dewar, 2002). Note that the exposure of the crossing is higher during the day time than the night time period (6:31 p.m. to 12:00 a.m.). When normalizing for differences in traffic volumes, studies showed that crash rates are much higher at night ((Yeh & Multer, 2008),(Darzentas & McDowell, 1981),(Leibowitz, 1985)).

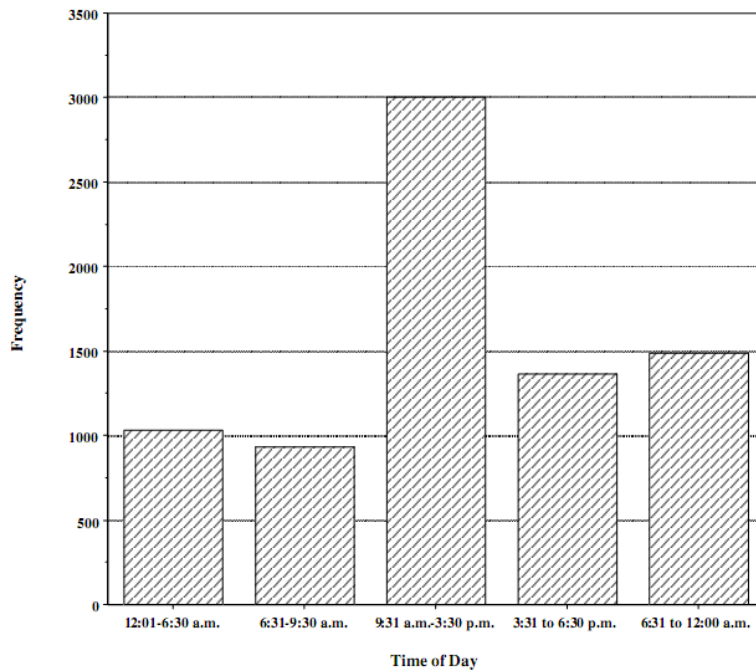

Figure 11 Crash Frequency by Time of Day [Source:(Caird, Creaser, Edwards, & Dewar, 2002)]

Ward & Wilde (1995) conducted an observation study to compare the speed profile and braking characteristics between day and night. The subject site is a flashing lights equipped crossing intersected with a 2 lanes roadway. The regulated speed for train and vehicles are 95 km/hr and 80 km/hr respectively. Both day and night observations indicated a speed reduction when vehicles approach the crossing. Results also showed that drivers approached the flashing light crossing more slowly at night and braked less. This implied the vehicles' entrance speeds are lower during night

time. Note that all observations of approach behaviors were conducted in open crossing. The differences in driving behaviors between day and night confine the data collection period available in this thesis.

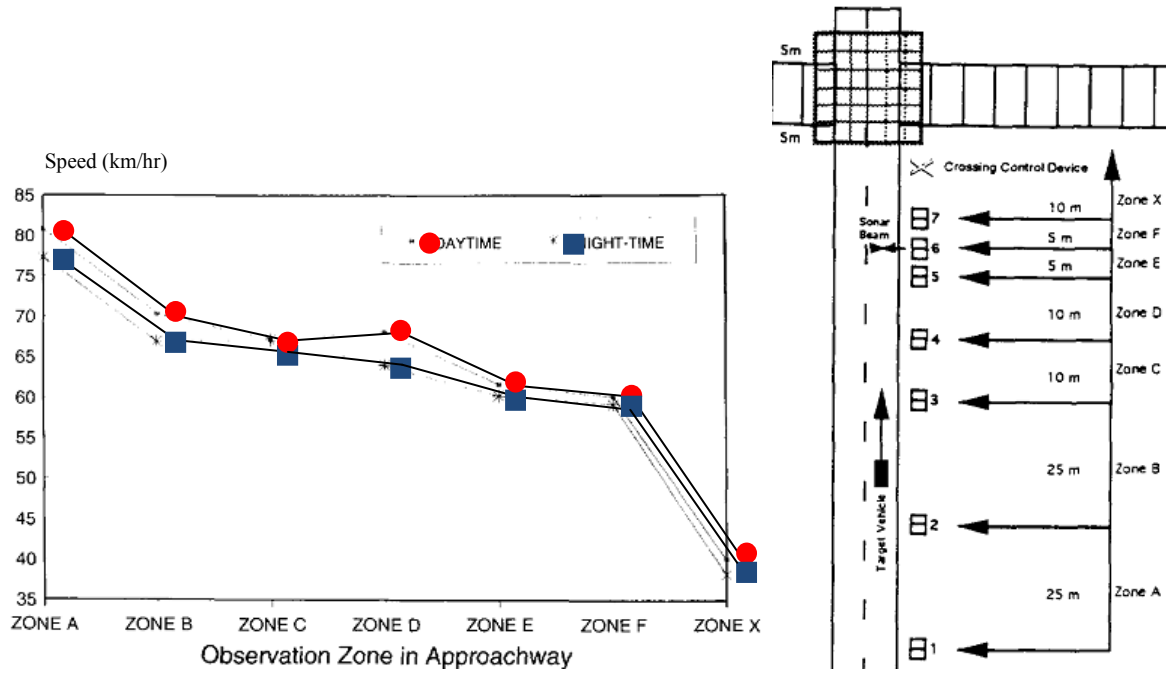

Figure 12 Profiles of Vehicle Speed [Source (Ward & Wilde, 1995)]

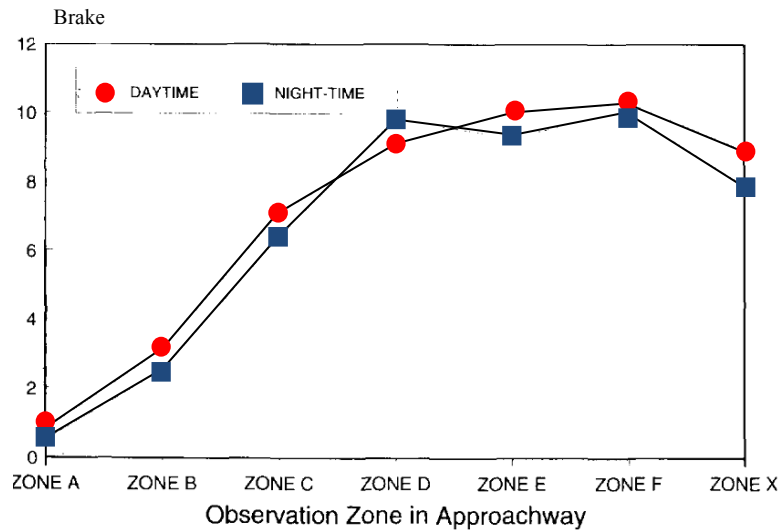

Figure 13 Profile of Brake Duration [Source (Ward & Wilde, 1995)]

### **3.2.3 Nearby Intersection**

Nearby Intersection beyond grade crossing (downstream) has long been a safety concern to agencies due to the potential spillback. If the storage distance between the track and the downstream signalized intersection is too short, residual vehicles accumulated in the previous signal in the downstream signalized intersection may have the potential blocking the grade crossing (Yeh & Multer, 2008). When the train arrives while the storage distance (including the track) is filled with vehicles, crash may result. According to Manual on Uniform Traffic Control Devices (MUTCD) (2009), preemption, the transfer or normal operation of a traffic control signal to a specific mode of operation, is required based on the following conditions.

*“At a signalized intersection that is located within 200 feet of a highway-rail grade crossing, measured from the edge of the track to the edge of the roadway, where the intersection traffic control signals are preempted by the approach of a train, all existing turning movements toward the highway-rail grade crossing should be prohibited during the signal preemption sequences.”*

Since potential spillback of vehicles from downstream intersection will affect the observation made to the approaching vehicle and its truncated signal phase (from the preemption strategy) are not of main interest, for the purpose of this thesis, the grade crossing setup and corresponding data collection discussed in later chapter should ensure no influence from nearby intersection is playing a role.

The consideration of the above factors in a simulation will alter the traffic pattern. To incorporate these factors into the thesis, network setup is modified and supplementary data collection is time restricted. Details will be described in later chapters. The change in these model components changes the resulting driving behaviors and individual vehicle movement in the simulation. The risk of rear-end vehicles interactions can be estimated by the surrogate measures of safety and the vehicle trajectory data.

### **3.3 Surrogate Measures of Safety**

Surrogate measures of safety are used to identify critical incidents and traffic conflicts; and evaluate different traffic engineering alternatives. The introduction of surrogate measures attempted to overcome the limitations of traditional crash-based safety analysis including but not limited to (i) the accuracy of crash rate prediction has always been a challenge to researchers due to its randomness.

(ii) crash reporting among jurisdictions are voluntary and data are incomplete as discussed in Section 2.3.1.

The data required for calculating various surrogate measures is the vehicle trajectory data. The vehicle specific location and time are used to deduce its corresponding speed, acceleration, deceleration, headway etc. These traffic attributes are the major components of all surrogate measures. These variables can be extracted from the site within a short amount of time comparing to the historical crash data, which is usually collected over several years. Instead of predicting the actual crashes using the historical crash data, surrogate conflict measures indicate the location with ‘higher probability of higher than average crashes rate’ (Gettman & Head, 2003). Table 1 lists the available safety conflict measures.

Table 4 Surrogate Safety Conflict Measures [Source: (Gettman & Head, 2003),(Cunto, 2008)]

<b>Surrogate Conflict Measure</b>	<b>Description</b>
Gap Time (GT)	Time lapse between completion of encroachment by turning vehicle and the arrival time of crossing vehicle if they continue with same speed and path. (Gettman & Head, 2003)
Encroachment Time (ET)	Time duration during which the turning vehicle infringes upon the right-of-way of through vehicle. (Gettman & Head, 2003)
Proportion of Stopping Distance (PSD)	Ratio of distance available to maneuver to the distance remaining to the projected location of crash. (Gettman & Head, 2003)
Post-Encroachment Time (PET)	Time lapse between end of encroachment of turning vehicle and the time that the through vehicle actually arrives at the potential point of crash. (Gettman & Head, 2003)
Initially Attempted Post-Encroachment Time (IAPT)	Time lapse between commencement of encroachment by turning vehicle plus the expected time for the through vehicle to reach the point of crash and the completion time of encroachment by turning vehicle. (Gettman & Head, 2003)
Time to Crash (TTC)	Expected time for two vehicles to collide if they remain at their present speed and on the same path. (Gettman & Head, 2003)
Unsafety Density Parameter (UD)	Ratio of unsafety occurrence to the total sectional length for the total simulation time. *“Unsafety” is a function of differential speed and lead vehicle deceleration
Deceleration Rate to Avoid the Crash (DRAC)	The required deceleration rate to avoid a crash if the offending vehicle continues with the same speed and trajectory. (Cunto, 2008)
Crash Potential Index (CPI)	Probability that a given vehicle DRAC exceeds its maximum available deceleration rate (MADR) during a given time interval. (Cunto, 2008)

In this research, Deceleration Rate to Avoid the Crash (DRAC) (Cooper & Ferguson, 1976), Time to Collision (TTC) (Hayward, 1972), Crash Potential Index (CPI) (Cunto, 2008), and Unsafety (Barcelo, Dumont, Montero, Perarnau, & Torday, 2003) are selected for evaluating the King Street Crossing safety. DRAC, are used as the primary safety performance (SP) indicators.

Instead of projecting a time of crash such as TTC, TTA, PET etc, DRAC quantify the risk by using the required braking estimate which is more reflective of crash avoidance.

Since this thesis focuses on the experimental design of applying commercially available simulation package to grade crossing, an assumption of vehicle braking power is unnecessary and CPI is also not suitable as the main safety performance measure.

Unsafety considers the actual braking of the lead vehicle and neglect the headway between the lead and following vehicles. Since the intuition of using deceleration rate in the following vehicle (DRAC) is more straightforward when compared to Unsafety, DRAC is more preferable than Unsafety for the purpose of the thesis.

In the sensitivity test section, the safety performance of the network is repeated using TTC, CPI, and Unsafety to reveal the potential difference in results. TTC is selected as part of the indicators in the case study due to its wide acceptance and being the most direct measure of drivers' perception of risk for rear-end crashes. Also, it is worth using CPI as a supplementary to check the potential differences in result when comparing to DRAC.

### 3.3.1 Deceleration Rate to Avoid the Crash (DRAC)

Deceleration rate to avoid the crash (Cooper & Ferguson, 1976) is the rate at which a vehicle must decelerate to avoid a collision with other conflicting vehicle. DRAC relates the deceleration for each time step to the time-space relationship of the vehicle pairs. Assumption has made on the constant speed and trajectory by the lead vehicle. This can be expressed as follows.

$$DRAC_{i,t+1} = \frac{(V_{i,t} - V_{i-1,t})^2}{2(X_{i-1,t} - X_{i,t}) - L_{i-1,t}} \quad [3-2]$$

where

t = time interval

X = position of the vehicle (i=following vehicle, i-1 = lead vehicle)

L = vehicle length



V = velocity

Hydén suggested the following braking levels classification (Source: (Hyden C. , 1996)).

Table 5 DRAC Severity Classification

Conflict Level	DRAC (m/s <sup>2</sup> )	Description
No Conflict	0	Evasive action not necessary
No Conflict	0 to 1	Adaptation necessary
1	1 to 2	Reaction necessary
2	2 to 4	Considerable reaction necessary
3	4 to 6	Heavy reaction necessary
4	≥ 6	Emergency reaction necessary

There are several drawbacks of DRAC.

1) DRAC does not consider vehicle capabilities (Cunto, 2008). Vehicles performances are expected to behave differently under different weather condition as tire friction is greatly affected by pavement condition.

2) The parameter is incapable of distinguishing the potential impact of different type of vehicles (Cunto, 2008). Heavy good vehicles are expected to react poorly than regular passenger cars on the same level of DRAC due to the less sensitive braking systems and larger masses.

### 3.3.2 Time to Crash (TTC)

Hayward (Hayward, 1972) defined time to collision as ‘the time required for two vehicles to collide if they continue at their present speeds and on the same path’. The TTC applied in rear-end interaction is the following expression.

$$TTC_{i,t} = \frac{(X_{i-1,t} - X_{i,t}) - L_{i-1,t}}{V_{i,t} - V_{i-1,t}} \quad [3-3]$$

Where

T = time interval

X = position of the vehicles (i= following vehicle, i-1 = lead vehicle)

L = vehicle length

V = velocity

The fundamental assumption of TTC is the existence of a crash course and the speed of the lead vehicle is less than the speed of following vehicle. The TTC value can be calculated for each simulation time step. The lower the value of TTC, the higher the crash potential. The most commonly used minimum acceptable safe threshold of TTC ( $TTC_{min}$ ) is 1.5 sec proposed by Van der Horst in 1990 (Horst, 1990).

There are several drawbacks of using TTC as the sole safety performance indicator.

1) TTC assumes drivers to exhibit constant speed throughout the trajectory. However, following vehicle usually undertakes corrective action to avoid a collision instead of maintaining a constant speed. The estimated crash does not consider any potential acceleration/deceleration pattern. Hence, it is not reflecting the real crash course between the vehicle pair. Also, the  $TTC_{min}$  would occur while the driver actually perceives the deceleration of the lead vehicle (reaction time). There is uncertainty about the reaction time among drivers.

2) It did not give any indication about the confidence of the conflicting vehicle pair detection (Ammoun & Nashashibi, 2009). TTC is estimated only if the lead vehicle speed is less than the following vehicle speed. However, vehicle speed can fluctuate over time, such as in a Stop-and Go condition.

3) The same TTC value can be generated by different vehicle trajectory combination. A higher speed vehicle under a larger headway would certainly result in a more severe crash than a low speed vehicle under small distance. The potential risks that arise from the following vehicle behavior depend on the vehicle performances.

### 3.3.3 Crash Potential Index (CPI)

Cunto developed Crash Potential Index (CPI) to better assess traffic safety performance by considering the braking capabilities of the following (reacting) vehicle.

$$CPI_i = \frac{\sum_{t=t_i}^{t_f} P(MADR^{(a_1, a_2, \dots, a_n)} \leq DRAC_{i,t}) \times \Delta t \times b}{T_i} \quad [3-4]$$

Where

$CPI_i$  = Crash Potential Index for vehicle  $i$

$DRAC_{i,t}$  = deceleration rate to avoid the crash ( $m/s^2$ )

$MADR^{(a_1, a_2, \dots, a_n)}$  = random variable following normal distribution for a given set of traffic and environmental attributes ( $a_1, a_2, \dots, a_n$ ) ( $m/s^2$ )

$t_{i_i}$  = initial simulated time interval for vehicle  $i$

$t_{f_i}$  = Final simulated time interval for vehicle  $i$

$\Delta t$  = Simulation time interval (sec)

$T_i$  = Total travel time for vehicle  $i$  (sec)

The main advantage of CPI is its ability to consider the following vehicle braking requirements to avoid the crash, the maximum available braking power (following vehicle) and the time exposed to the interaction. The braking requirement for a vehicle interaction at the specific time step is represented by DRAC using 3-2. The maximum available deceleration rate (MADR) is a stochastic component introduced to account for different vehicles categories under different pavement conditions.

Unlike other safety performance measures which only require on-site vehicle trajectory data, the use of MADR require an understanding of vehicle capabilities characteristic on the local area which demand extra data collection effort. It is selected as one of the indicator for the safety performance measures comparison in case study section due to its consideration of hypothetical braking power.

### 3.3.4 Unsafety

Barceló et al. (Barcelo, Dumont, Montero, Perarnau, & Torday, 2003) developed a safety indicator using the three fundamental microsimulation outputs which are the relative positions, speeds, and decelerations of each lead and following vehicle pair. A 2-second reaction time was assumed for all drivers. The index gives an insight into the potential of a crash if “the follower vehicles’s reaction time is equal to the standard time reaction (2 seconds) and the leader vehicle breaks with its maximum deceleration capacity” (Barcelo, Dumont, Montero, Perarnau, & Torday, 2003).

The index consists of two portions. First, an “Unsafety” level is used to relate the lead and following vehicle pairs on the road for a given simulation time step. If the “hypothetical” crash does not occur or the lead vehicle is not decelerating, the value of the “unsafety” parameter is zero.

$$Unsafety = \Delta S \times S \times R_d \quad [3-5]$$

Where

$\Delta S$  = differential speed between the lead and following vehicle

$S$  = Speed of the following vehicle

$R_d = b/b_{max}$  if  $b > 0$  ;  $R_d = 0$  else ( $b$  is the deceleration from lead vehicle)

The first portion was embedded into the second portion to describe the safety of network as a whole using the following equation:

$$Unsafety\ Density = \frac{\sum_{s=1}^{S_t} \sum_{v=1}^{V_t} Unsafety_{v,s} \times d}{T \times L} \quad [3-6]$$

Where

$V_t$  = number of vehicles in the link

$S_t$  = number of simulation steps within aggregation period

$d$  = simulation step duration [s]

$T$  = aggregation period duration [s]

$L$  = section length [m]

The author has identified several drawbacks of the UD parameters: (i) the measure is restricted to potential rear-end crashes only; (ii) the unsafety factor expression has little mathematical meaning unless the Unsafety Density is used only for comparison purposes. Besides, using a fixed following driving reaction time will increase the bias in the UD measure. UD values are greater than zero only when the lead vehicle is braking and thus some conflicts that take place during Stop-and-Go situations are not considered.

Unsafety is selected as another indicator for the safety performance measures comparison in the case study section due to its special application in rear-end interaction. Instead of estimating the required deceleration as in DRAC, Unsafety uses the actual deceleration from the lead vehicle in the

calculation. Since UD represent the aggregation for the entire link, it is not a suitable measure for this thesis.

## **Chapter 4**

### **VISSIM Modification, Calibration and Validation**

In Chapter 3, it was suggested that VISSIM had no direct function for modeling grade crossings. Modifications to the program logic are required to fully reflect microscopic driving behavior at these crossings. These modifications are calibrated with respect to observed data from a videotaped crossing, and a number of input parameters specified based on these observations. The calibrated model is then validated by comparing road vehicle speed profile to observed crossing data. The King Street crossing discussed in Section 3.2.1 is used as a basis for the crossing geometry setup in this thesis.

#### **4.1.1 VISSIM Railroad Crossing Demo Crossing**

In a demo application provided by VISSIM, railroad crossing operations were modeled using the existing setup for signalized intersections. In the setup, detectors, one of the VISSIM features, are placed on the track to monitor the train movement. A “call” detector is used to identify the train arrival at the upstream section and a “cancel” detector is used to confirm the train departure from the vicinity of the track. Once a train reaches the call detector, stage 2 is activated that closes the road for vehicles by showing a ‘red signal’ and clears the railroad track. Finally, if the last carriage of the train left the cancel detector on the far end of the junction, stage 1 is activated by showing the ‘green signal’ to clear the way for the road vehicles. The VISSIM grade crossing demo failed to differentiate microscopic driving behaviors. For instance, it failed to evaluate drivers from different lanes react to the descending and ascending gate. Also, the speed reduction behavior in an open crossing was not considered.

#### **4.1.2 Required Modification in Gated Crossing**

Since the program is designed for roadway crossings, warning traffic devices used in grade crossing were not considered explicitly. Hence, the modifications listed in the following sections are based on features currently in VISSIM as applied to signal and unsignalized intersections. There are three stages for a gated crossing operation which require logic modifications for train arrival: (i) Open Crossing, (ii) Flashing Light Activated (train approaching), and (iii) Gate Ascend (train departing).

#### 4.1.2.1 Open Crossing

In Section 3.2.1, the reduce speed profiles associated with road vehicle approaching the track and this specific characteristic should be captured.

**Modification:** VISSIM has “Reduced speed area” logic to model short section of slow speed characteristic occurring at intersection or crossing. For grade crossings, the reduce speed area corresponds to 1 m or 2 m on the approach side of the track. A unique desired speed, also referred to track crossing speed, is assigned to different classes of vehicles. This information is used to obtain the deceleration profile and intermediate speeds in the approach zones. The deceleration will take place upstream of the reduced speed area based on the entrance speed of the vehicle, distance to the track, crossing speed threshold, and maximum deceleration rate. The lower the maximum deceleration rate, the further away a vehicle initiates the deceleration to achieve the crossing speed threshold. Vehicles automatically accelerate to original desire speed after leaving the reduce speed area. The magnitude of this acceleration is based on the aggressiveness of the driver and their original desire speeds. If the distance available is insufficient for vehicles to undertake the maximum deceleration, the drivers will cross the track at a speed higher than the crossing speed threshold.

#### 4.1.2.2 Flashing and Gate Descending

The major factors governing the state of flashing and gate descending are whether drivers decide to cross the track when the light starts to flash and the percentage of vehicles crossing the track after the gate starts to descend, but has yet to be fully deployed. Also, possible differences in driver reaction might result from being on different lanes (center/shoulder). Drivers from center lanes theoretically have a bigger gap available from which to drive under the gate as compared to drivers in the shoulder lane. In this thesis, modifications to VISSIM logic are introduced to account for this type of behavior. This logic does not permit lane changing in the vicinity of the crossing.

**Modification:** When the transponder placed at about 230 m from the crossing detects the train, the crossing warning device is activated. This could be the beginning of the flashing light and in the case of a gated crossing, gates begin to descend 3 seconds later. The gate becomes fully extended over a period of 10 seconds.

While aggressive drivers will cross under the gate, cautious drivers will decelerate to a full stop. The situation is similar to the amber dilemma in fixed signalized intersections. Drivers are expected to stop if they have enough stopping distance. Hence, the entire process of flashing light and gate

descending is similar to drivers' reactions during the amber signal phase at a signalized intersection, while fully extended gate reflects the red signal phase. In One Decision logic (PTV, 2008), the probability of the driver stopping at the amber light is governed by the following formula. A decision is kept until the vehicle has passed the stop line/gate. "One Decision" decision logic used in simulating reaction to amber signal will also be used in grade crossing. The 3 parameters in the One Decision logic are calibrated using the speed and location data recorded at the study site.

$$p = \frac{1}{1 + e^{-\alpha - \beta_1 v - \beta_2 dx}} \quad [4-1]$$

Where

p - Probability of stopping

v – Velocity

dx – Distance from the track

$\alpha, \beta_1, \beta_2$  - Constant

Since the traffic signal of each lane in VISSIM is governed by its own signal head, different amber times have been employed to differentiate the different driving behaviors in the center and shoulder lane. Figure 14 shows the traffic operation in VISSIM settings. The virtual signal is shown as green indicating an opening crossing. While flashing light initiated, the amber signal control is activated. There is a difference in amber time allocation for the center and the shoulder lane. When the gate is fully deployed, all vehicles must come to a stop. This is controlled in VISSIM by using a red signal blocking the traffic while the train is passing through.

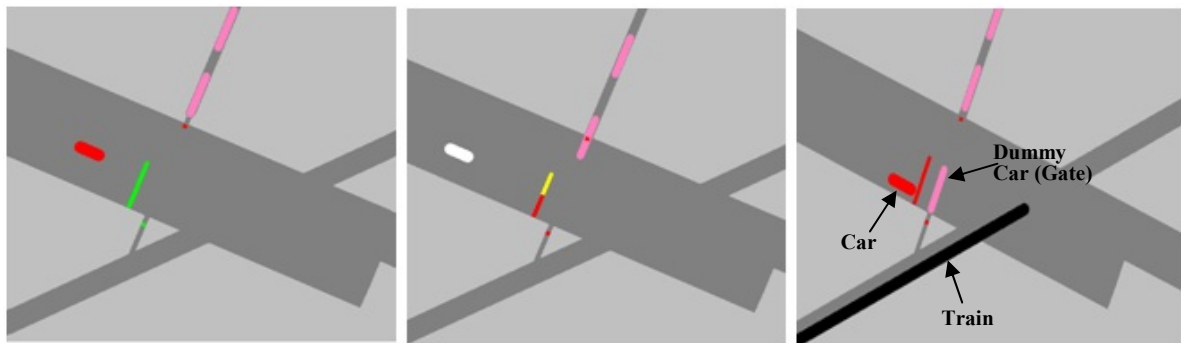

Figure 14 VISSIM representation of train arrival



### 4.1.2.3 Gate Ascending

When the train exits the intersection and activates the “Cancel” detector, the gates start ascending. The flashing light immediately turns off once the gates are fully extended up. As in the case of a signalized intersection, some drivers will release the brake once they realize the intersecting traffic has stopped and the traffic light is going to turn from red to green. Similar behavior is expected in grade crossing. Once the gate ascends from center lane, drivers will start releasing the brake. Videos obtained from previous studies also revealed that many drivers cross the track before the flashing light goes off. Percentage of vehicle crossing the track with respect to time after gate start to ascend needs to be addressed in the VISSIM logic.

**Modification:** The dispersing behavior is modeled by the gap acceptance logic. A dummy vehicle is introduced to mimic the gate ascending phase of the crossing. As indicated in Figure 14, this dummy vehicle (in pink) is assigned to a separate link representing a gate. As previously discussed, the signal control (Amber/Red) governs the vehicle stopping behavior in flashing light and gate descending state. A virtual car blocks the lanes when the train is approaching, which represents a fully-descend gate where no traffic can go thru the grade crossing.

When the train departs the intersection and detected by at the cancel detector, the dummy car discharges mimicking the ascending gate. The gap acceptance logic of stopped vehicles is governed by the “priority rule” decision making in VISSIM (PTV, 2008)) discussed previously. In this research, minimum headway (distance) at the conflict marker(s) determines whether the stop line allows vehicles to cross or not (Figure 15).

All approaching cars are divided into groups to represent a distribution of drivers’ behavior. For example, aggressive drivers will accept a smaller headway (gate are still ascending) and proceed through the crossing. Hence, headway has to be determined through data collection which will be discussed in later section. The speed of the dummy car is a function of the lane widths and the time taken from the gate to descend from horizontal to fully upright position.

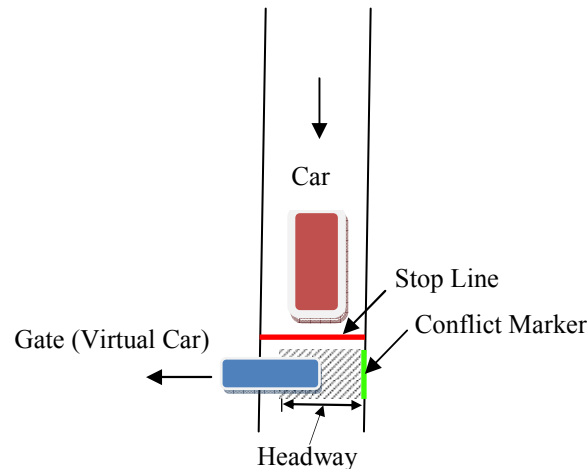

Figure 15 Priority Rules Logic in VISSIM

## 4.2 Model Parameters Calibration

A two-step calibration was used in this thesis. The car-following parameters are based on similar geometric configuration of a signalized intersection. Lane changing is disabled in the network to ensure the observed driving behaviors are due to turbulence generated from the track area. Data collections of the selected site will be used to calibrate gap acceptance parameters whose values are expected to be significant in a grade crossing operation. As previously discussed, the King Street crossing in Kitchener, Ontario will be used as the network base.

### 4.2.1 Parameters Obtained from Literature

The logic of flashing light and gate descending in a grade crossing are similar to the amber dilemma in a signalized intersection. The car-following behavior is assumed to be transferrable between the two types of signal control. There are several studies regarding VISSIM parameters calibration. The majority of the studies related traffic operation such as delay, vehicle speed, and traffic flow, etc. to the measure of effectiveness for the calibration [(Yu, Yu, Chen, Wan, & Guo, 2006),(Robert & Esplain, 2005),(Mathew & Radhakrishnan, 2010)].

Cunto & Saccomanno (2008) previously calibrated and validated driving parameters in VISSIM for a signalized intersection. The calibration framework is presented in Figure 16. The authors concluded the methodology into five computational steps as follows:

1. Heuristic selection of initial model inputs.

2. Initial statistical screening of inputs (Plackett-Burnman with folderover).
3. Establishing linear expression relating significant inputs to safety performance (fractional factorial analysis).
4. Obtaining best estimates of model Inputs using a genetic algorithm.
5. Validating selected inputs based on independent traffic sample.

Among all available driving parameters, Cunto and Saccomanno (2008) revealed three parameters which are most sensitive and the values which best represent traffic operation at a signalized intersection. The parameters used in this thesis are shown in Table 6.

Table 6 Calibrated Driving Parameters [Sources:(Cunto & Saccomanno, 2008)]

Driving Parameters	Calibrated Value
Desired deceleration	-2.6 m/s <sup>2</sup>
CC0	3.0
CC1	1.5

Note: Desired deceleration – used in achieving predefined desired speed or under Stop-and-Go condition; CC0 – Standstill Distance (m) which is the desire distance between stopped car; CC1 – Headway Time (s) which is the time that the following vehicle driver wants to keep with the lead vehicle. CC0 and CC1 are being used in determining the safety distance.

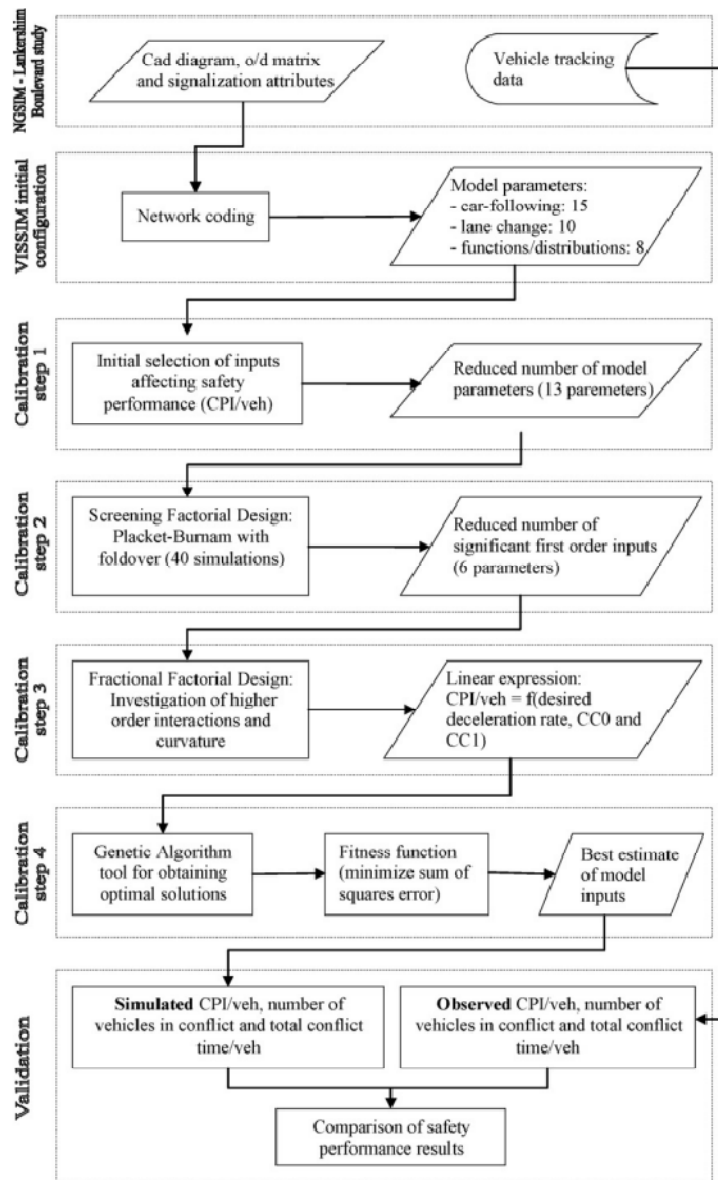

Figure 16 Calibration/Validation Study Framework by Cunto [Source: (2008)]

#### 4.2.2 Fine-Tune Calibration Thru Data Collection

The unique driving behaviors described in Section 4.1.2 such as reduced speed area are not reflected in signalized intersections. Also, traffic characteristics of the grade crossing need to be identified. Supplementary data collection was conducted at the King Street crossing to obtain specific driving parameters for gated crossing during train arrival.



Figure 17 Camera Position Source: [Source: (Google, 2010)]

The following data were recorded.

- Gap Acceptance – Train approaching
  - In each videotape, the decision and reaction of the lead vehicle in both lanes were recorded. The items recorded are:
    - Time stamp of light start flashing
    - Position of the lead vehicle (Distance from the Track)
    - Velocity of the lead vehicle at that time stamp
    - Binary variable denoting “stop” or “go”
  
- Gap Acceptance – Train departing
  - In each video taping, the decision and reaction of the first stopped vehicle in both lanes are recorded. The items recorded are:

- Time stamp of gate start ascending
- Time stamp of the stopped vehicle start releasing the brake

#### 4.2.2.1 Speed Reduction Area

The desired speed distribution and maximum deceleration applied in the study area is based on the data collection conducted in the preliminary study. The maximum deceleration is  $3.77 \text{ m/s}^2$  and the minimum and maximum speed at the track are  $24.0 \text{ m/s}$  and  $58.9 \text{ m/s}$  (Figure 18). During the train arrival period, the deceleration/stopping behavior is governed by the signal control. When the train arrives, the deceleration/stopping behavior is governed by the signal control. When the train departs, the acceleration/start up behavior is determined by the gap acceptance model (with the gate). The effect of reduce speed area in train arrival and train departure on driving behavior is minimal.

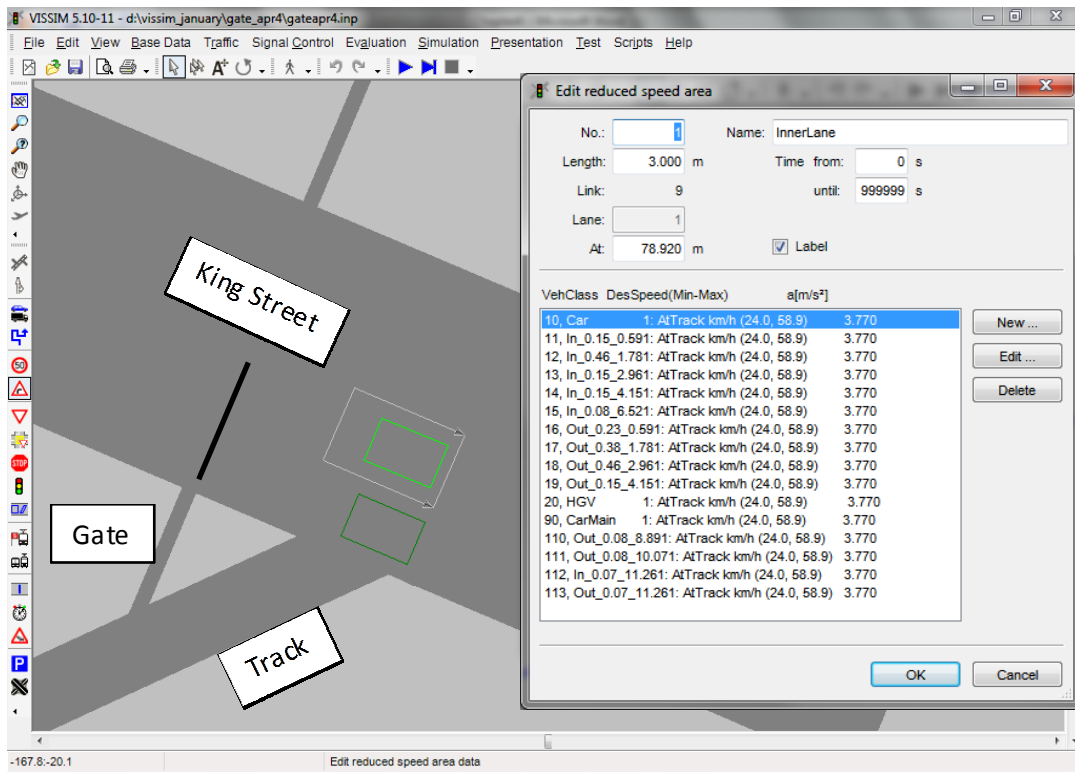

Figure 18 VISSIM Modification for Vehicle Distribution

#### 4.2.2.2 Signal control

Signal control will be used to simulate the flashing light and descending gate. SPSS has been used to analyze the 34 samples collected in the data collection. Alpha 1, beta 1, and beta 2 were estimated to

be -0.43, -0.36, and 0.13 respectively (Figure 19). The details of the statistical test are shown in Appendix B.

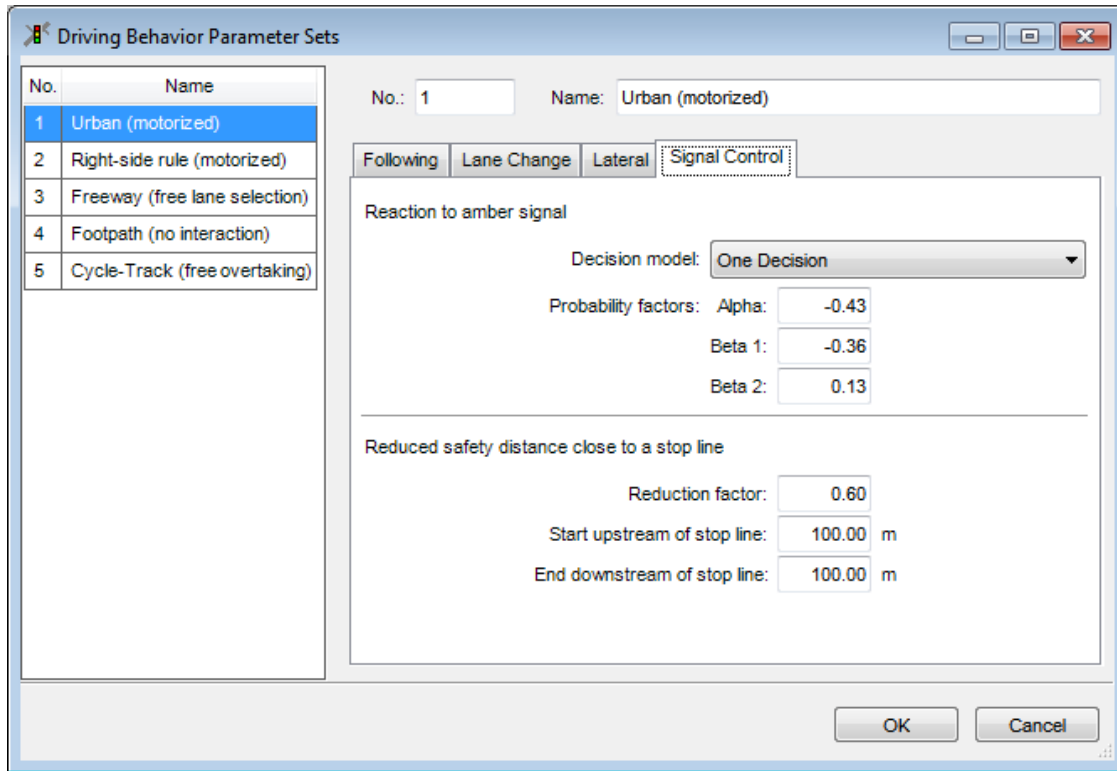

Figure 19 VISSIM Modification for Flashing Light and Gate Descend

Based on the video, the amber times preset for the shoulder and center lane are 8 and 13 seconds respectively.

#### 4.2.2.3 Gate Ascending

As discussed, priority rule will be used to model the vehicle dispersing behavior when the gate ascends. The data recorded the gap acceptance behavior of the lead stopped vehicle in each lane. Only the most front vehicle in each lane is considered as there is no preceding vehicle which biases their decision making process. The time drivers release their brake after the gate beginning to ascend was recorded. These data are summarized in the following cumulative plot.

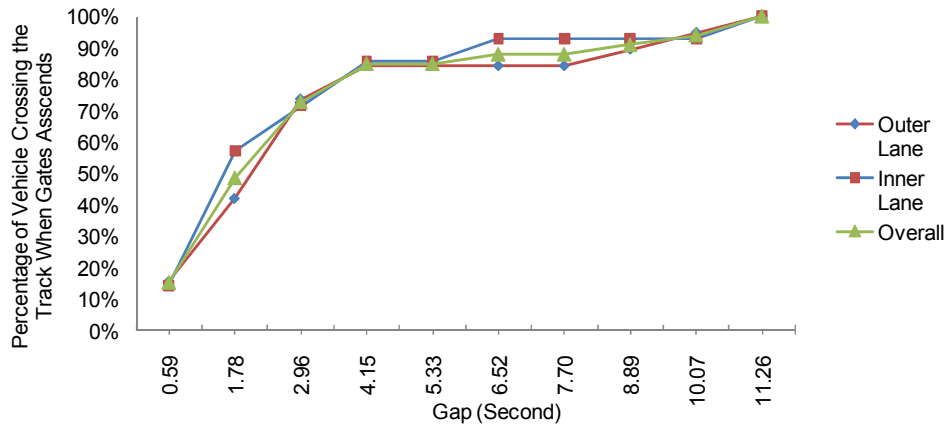

Figure 20 Gap Acceptance – Train Departing

In order to use the priority rules logic, these gap times from data collection need to be transformed into headway using the following formula.

$$H = V \times G \quad [4-2]$$

Where

H = headway (m)

V = velocity of virtual gate (gate movement rate) (m/s)

G = gap time (sec)

It takes six seconds for the gate to ascend from horizontal to upright position. Each lane is about 3.3 m. The hypothetical virtual car velocity then comes to 1.1 m/s. Instead of assigning a single value of gap acceptance, five different vehicle types are used in each lane respectively to represent the different driving characteristic (Figure 20). The conflict marker for the headway starts from the center lane.



Table 7 Priority Rules Headway Allocation

Vehicle Class	Lane	Headway (m)	Percentage
1	Center	0.65	15 %
2	Center	1.96	46 %
3	Center	3.26	15 %
4	Center	4.56	15 %
5	Center	7.17	9 %
6	Shoulder	2.20	16%
7	Shoulder	2.20	28%
8	Shoulder	3.26	33%
9	Shoulder	4.56	11%
10	Shoulder	9.78	6%
11	Shoulder	11.08	6%

### 4.3 Validation

The validation of the VISSIM logic in this thesis is based on a comparison between VISSIM outputs and the preliminary observational data study discussed in Section 3.2.1. The VISSIM network setup (blue lined) is based on the local geometry of the King Street crossing (Figure 21). The upstream intersection was not added to the King Street crossing so that the crossing can be studied as an isolated crossing with no nearby intersection. All traffic inputs were assumed to be undisturbed by any other roadway signal (e.g. upstream signalized intersection) except the grade crossing signal. All the modifications indicated in the previous chapter were implemented in the logic setup.

The speed profile generated from VISSIM has been compared to the observed profile from King Street crossing as in Figure 22. The result is reasonable suggesting that the VISSIM has been able to simulate vehicle interactions in the vicinity of a crossing. The bulk of the speed reduction at King Street took place nearer the track in Zone 2. VISSIM output data has been processed to estimate maximum deceleration requirement for upstream section (Zone 1) and downstream section (Zone 2).

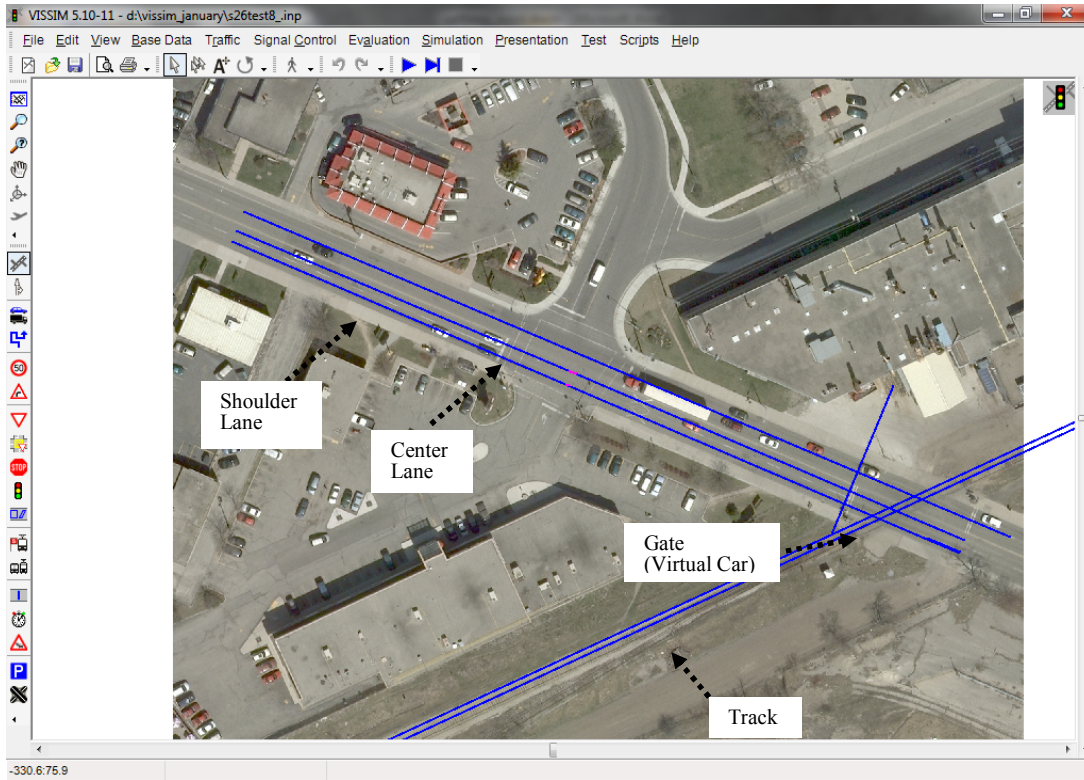

Figure 21 VISSIM Network Setup

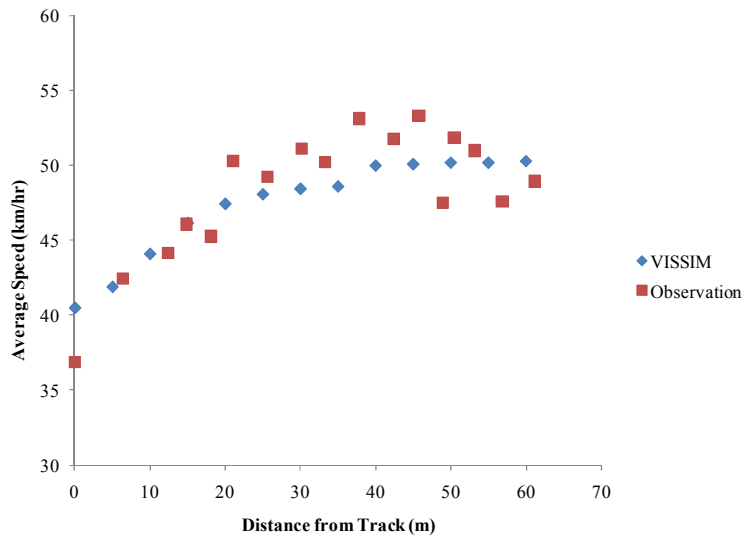

Figure 22 Speed Reduction Profile Comparison between VISSIM and Observation

Besides speed profile comparison, the zonal effects represented by safety performance measures are also compared. In the preliminary study, a safety performance profile was obtained for the King Street crossing based on both the average and 90<sup>th</sup> percentile values of CPI/veh as extracted from the video data for the two crossing zonal segments. The measure of CPI required a pairing of following to lead vehicle from the individual vehicle profiles. The results are illustrated in Figure 23.

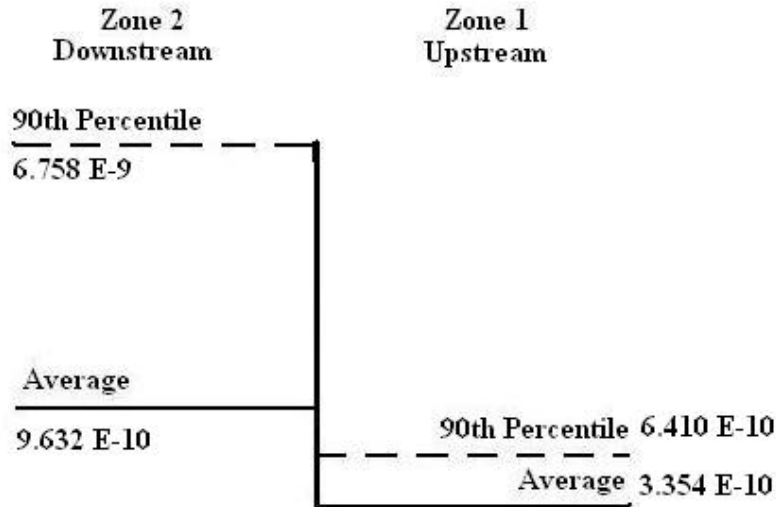

Figure 23 Comparison of CPI/veh between Upstream and Crossing area

Higher levels of CPI per vehicle reflect lower safety performance. A number of observations were obtained from this figure:

Both average and 90<sup>th</sup> percentile measures of CPI per vehicle are significantly higher in Zone 2 nearer to the track, and this is due in large part to differences in vehicle speed and deceleration rates between the two zonal segments. The 90<sup>th</sup> percentile value in Zone 1 is closer to the mean value obtained for Zone 2.

Variation about the mean CPI/veh in Zone 2 is considerably higher than in Zone 1, suggesting that there is a wider range of vehicle interactions in this zone that could compromise safety. For Zone 2 a few vehicle pairs were observed to experience unusually high levels of risk (6.578 E-9). The narrower range of CPI/veh values in Zone 1 suggests a less abrupt speed reduction response from individual vehicles and a reduced chance of unsafe rear-end interactions.

In Zone 2, the level of crash risk increases with distance to the track, whereas in Zone 1 the values CPI/veh were found to be fairly uniform.

As in previous studies from the literature (Section 3.2.1), the King Street speed profile fails to provide a definitive point upstream of the crossing where speed reduction is initiated. An increase in CPI/veh is experienced primarily within the 30 m segment nearest to the track (Zone 2).

Since crash risk is expected to be higher in Zone 2 (higher CPI/veh), the possibility of vehicle entrapment between barriers at gate-equipped crossings, vehicles being “pushed” onto the track and or vehicles becoming disabled on the track becomes especially problematic. Any evaluation of crossing countermeasures should consider these risks.

The traffic condition from the preliminary study is input into VISSIM. Maximum deceleration rate to avoid a possible crash (DRAC) is estimated based on the vehicle trajectory data. The DRAC values were found to be  $0.10 \text{ m/s}^2$  in Zone 1 and  $0.11 \text{ m/s}^2$  in Zone 2. The increase in risk in Zone 2 is consistent with the findings in the preliminary study.

## Chapter 5

### Linking DRAC to High Risk Behaviors for Different Traffic Scenarios

This chapter studies the impact on safety performance of changes in traffic attributes for different scenarios for a given grade crossing. Initially, traffic scenarios considered in the sensitivity test are discussed. These scenarios consist of different combinations of relevant traffic attributes. An n-way ANOVA (with interactions) is carried out to investigate the significance of these attributes in explaining variation in safety performance measures.

#### 5.1 Traffic Attributes

Based on engineering judgment, three traffic attributes were selected for the sensitivity test: total traffic volume, percentage of buses, percentage of cars in the center lane. The selection of these attributes underlies fundamental traffic flow relationships as illustrated in Figure 24.

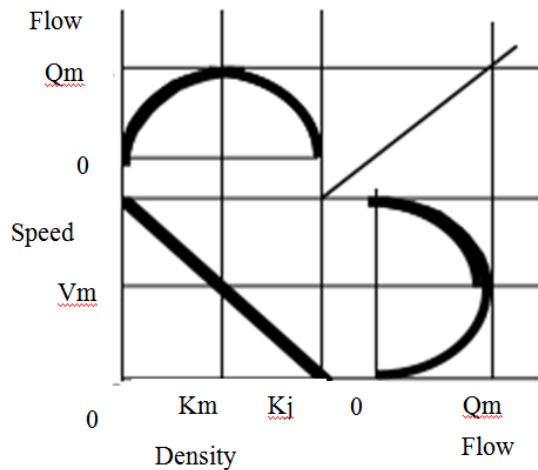

Figure 24 Fundamental of Traffic Flow [Source: (Levinson, 2008)]

There is a difference between 'Volume' and 'Flow'. While Volume indicated the desired input traffic volume to the network, Flow refers to the actual vehicles that are able to travel through the network depending on the traffic condition (free flow/congested). In a Flow-Density relationship, density will be close to 0 when the traffic volume (flow) is low. Vehicles in this stage are travelling on free flow speed. On the contrary, in a congested situation where density is high, the actual flow of

vehicles is minimal. In Speed-Density relationship, vehicles speed is inversely proportional to the density of vehicles in the traffic stream. The more congested the network, the slower the vehicle travel speed. In Speed-Flow relationship, the same flow can correspond to two different speed (except the point of equilibrium at  $Q_m$ ). While the top part corresponds to the uncongested region where vehicles travels in high speed, the lower part of the Speed-Flow plot indicates the congested area.

#### Total Traffic Volume

From the above figure, traffic volumes affect speed and density. These changes will alter rear-end vehicle interactions that is of interest in this study. In the simulation, three classes of traffic volume from Figure 8 will be assigned in a south bound direction along King Street.

#### Percentage of Buses

Buses are required to come to a full stop when approaching a grade crossing, and this create a class of vehicle in the traffic stream with unique speed and deceleration profile (as compared to cars). The introduction of bus will have an impact on the density and flow in the network. Three levels of percentages of buses will be assigned to the shoulder lane only along King Street (Figure 8).

#### Percentage of Cars in the Center Lane

Since buses are restricted to the shoulder lane, vehicles in the center lane are expected to experience a different speed profile from the shoulder lane. As shown in the above figure, the change in speed profile will affect the flow and density correspondingly. Trucks are allocated between center lane and shoulder lane on a 50:50 basis along King Street. Hence, trucks are expected to affect vehicles in both lanes uniformly. Three levels of percentages of cars in center lane will be assigned (Figure 8).

In addition to the above traffic attributes, the road segment has been divided into two zones. Based on the reduce speed profiles discussed in Section 3.2.1, two distinct speed regimes were observed to take place in the approach segment of the grade crossing. The two zones considered are: Zone 2 (0 to 20 m from the track) and Zone 1 (20 to 60 m from the track).

In the traffic scenario sensitivity analysis, all traffic attributes and their classes were combined to yield a mix of 27 specific scenarios for each of zonal segment as summarized in Table 8.

VISSIM is run for 30 simulations for each of the 27 traffic scenarios. Since this analysis considers only one approach for a single crossing, a 60-second warm-up period is employed to fill up the empty network and achieve realistic results during the rest of the simulation. Based on previous data

collection, one train was introduced into each run with a fixed approach speed (40 km/hr) and length (65 m). After each simulation, the output file generated by VISSIM was processed to extract vehicle trajectory information and calculate the results in safety performance measures.

Table 8 Traffic Related Factors and Corresponding Levels

Factor	Level
Zone	Zone 1, Zone 2
Bus	0%, 5%, 20%
Volume (Veh/hr/approach)	500, 1000, 2000
Lane Distribution	0.1(in);0.9(out), 0.5(in);0.5(out), 0.9(in);0.1(out)

The simulations generated vehicles trajectory data for each scenario. These raw data were processed in order to calculate various safety performance measures. The procedures of the data extraction as illustrated in Appendix C.

## 5.2 ANOVA Test Layout

As indicated previously, the focus of interest in the ANOVA sensitivity test is the relationship between different traffic attributes and safety performance measures. For this initial test, DRAC is used as the basic measures of safety performance. To reflect high risk situations (potential conflicts), DRAC was obtained from the simulation for each vehicle in the traffic stream in 0.1 second time increment and the 85<sup>th</sup> Percentile value of DRAC (DRAC85) was estimated based on the entire traffic stream for each of the two zones. The DRAC85 values were estimated for each of the 27 traffic scenarios. The simulation was carried out for 30 repetitive runs in each traffic scenario using different number seeds. The structure of the sensitivity test is illustrated in Table 9.

Table 9 Data Layout

Zone <sub>i</sub>			
	Run 1	...	Run 30
Scenario 1	DRAC <sub>1,1</sub>		DRAC <sub>1,30</sub>
⋮			
Scenario 27	DRAC <sub>27,1</sub>	..	DRAC <sub>30,1</sub>

### 5.3 ANOVA Test Result

The results of the n-way ANOVA with interactions terms applied to the 27 traffic scenarios and 2 traffic zones are summarized in Table 10, along with their level of significance. The factors that were found to be significant at the 5% level are highlighted in this table. The results demonstrated statistical significant for a number of main effects (single order), two-factor interactions (second order), and three-factor interactions (third order).



Table 10 ANOVA Results based on DRAC

Dependent Variable: DRAC					
Source	DF	Type III SS	Mean Square	F Value	Pr > F
<b>Volume</b>	<b>1</b>	<b>0.330</b>	<b>0.330</b>	<b>484.91</b>	<b>&lt;.0001</b>
Bus	1	0.000	0.000	0.44	0.508
Volume*Bus	1	0.001	0.001	1.80	0.179
<b>Lane</b>	<b>1</b>	<b>0.006</b>	<b>0.006</b>	<b>8.30</b>	<b>0.004</b>
<b>Volume *Lane</b>	<b>1</b>	<b>0.005</b>	<b>0.005</b>	<b>7.52</b>	<b>0.006</b>
<b>Bus*Lane</b>	<b>1</b>	<b>0.025</b>	<b>0.025</b>	<b>36.81</b>	<b>&lt;.0001</b>
<b>Volume *Bus*Lane</b>	<b>1</b>	<b>0.010</b>	<b>0.010</b>	<b>15.15</b>	<b>0.000</b>
<b>Zone</b>	<b>1</b>	<b>0.010</b>	<b>0.010</b>	<b>15.24</b>	<b>&lt;.0001</b>
Volume *Zone	1	0.001	0.001	1.89	0.169
<b>Bus*Zone</b>	<b>1</b>	<b>0.217</b>	<b>0.217</b>	<b>317.72</b>	<b>&lt;.0001</b>
<b>Volume *Bus*Zone</b>	<b>1</b>	<b>0.037</b>	<b>0.037</b>	<b>53.98</b>	<b>&lt;.0001</b>
Lane*Zone	1	0.002	0.002	2.97	0.085
Volume *Lane*Zone	1	0.002	0.002	2.52	0.113
<b>Bus*Lane*Zone</b>	<b>1</b>	<b>0.034</b>	<b>0.034</b>	<b>50.17</b>	<b>&lt;.0001</b>
Volume *Bus*Lane*Zone	1	0.001	0.001	1.29	0.2571

Note:<sup>1</sup> Bold item indicated the significance of that specific treatment combination

<sup>2</sup> Volume = Total Traffic Volume; Bus = Percentage of buses; Lane = Percentage of cars in center lane; Zone = Zonal effect (closer to the track – Zone 2, upstream section – Zone 1)

Factors Volume, Lane, and Zone were found to have a significant effect on DRAC85 at the 5% level (Table 10). This suggests that these factors have a significant contribution in explaining higher risk behavior in the traffic stream. The significant second order effects at the 5% level were found to be volume-lane, bus-lane, and bus-zone. Interaction effects reflect the combined influence of the two individual attributes being considered in explaining variation in DRAC85.

For example, the combination of percentages of buses in the shoulder lane and percentage of cars in the center lane has significant effects on high risk deceleration in the traffic stream. The following section explains the significant terms in details. Table 10 indicates three significant third order effects (volume-bus-lane; volume-bus-zone, bus-lane-zone). These effects suggest there are complex interactions between selected traffic attributes and zone in explaining variation in high risk deceleration profile in the vicinity of the simulated crossing.

#### Main Effect

The relationship between DRAC85 and factors Zone, Lane, Volume is illustrated in Figure 25.

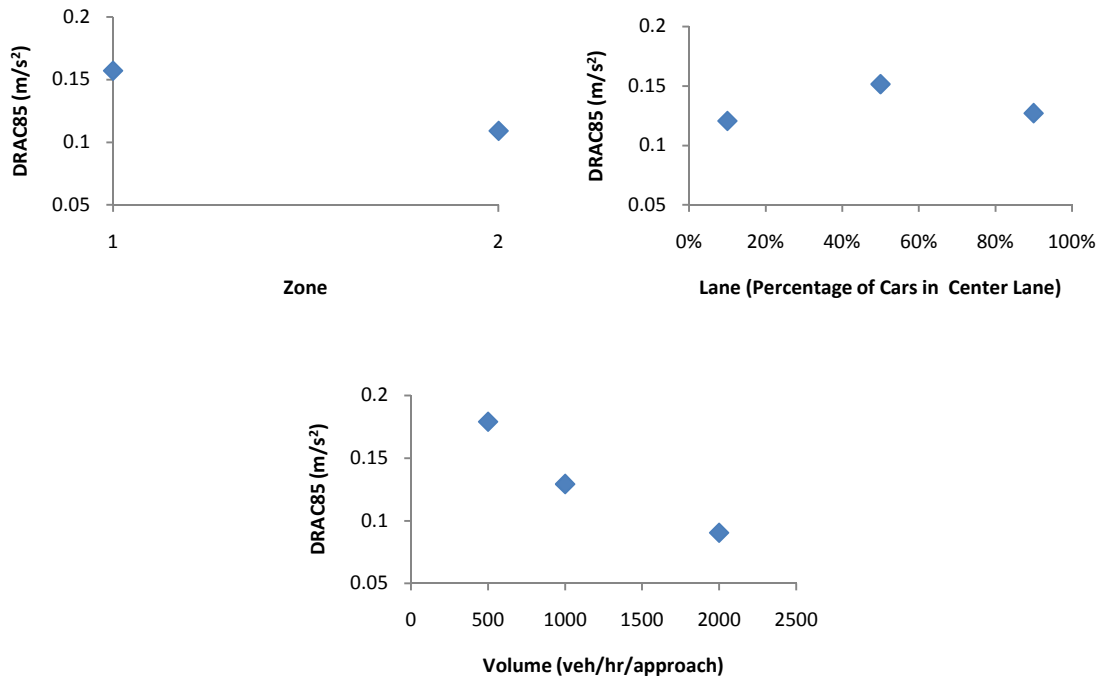

Figure 25 Main Effects

## ZONE

Figure 25 indicates that the DRAC85 value in Zone 2 is lower than in Zone 1 suggesting that Zone 2 has reduced high risk vehicles interactions and increased safety when a train is present. This suggested a contradiction with previous results (discussed in Section 3.2.1) where high risk deceleration is observed in Zone 2 in the absence of a train. The introduction of train improves the safety in the vicinity of the track since vehicles are expected to stop under an active warning device (the simulated King Street Crossing). For a rear-end interaction in an open crossing, the following vehicle driver remains uncertain about the lead vehicle movement (the magnitude of speed reduction). This creates uncertainty which creates higher DRAC85 Values in Zone 2. The speed reduction effect is dampened by the presence of a train.

## VOLUME

As illustrated in Figure 25, as the volume increases, high risk decelerations (DRAC85) are reduced. As the total traffic volume increases, the overall traffic stream speed decreases as congestion builds up. Since DRAC85 is affected by speed differential between vehicles, a more uniform and lower speed profiles will decrease this measure and hence, improve safety.

## LANE

The overall DRAC85 values in traffic scenario with 50:50 lane distribution in center to shoulder lane is significantly higher than other lane distribution (0.1:0.9 and 0.9:0.1) regardless of the traffic volume. For the latter case, this could be explained by the overloading traffic volume in a given lane regardless of the center lane or the shoulder lane. Applying the same logic of the main effect in Volume, the increases in volume on a per lane basis decreases overall travel speed on each lane and improves safety.

### Two-Factors Interaction Effect

The relationship between DRAC85 and factors Zone-Bus, Bus-Lane, Volume-Lane are illustrated in Figure 26. Note that if the lines on the interaction plot are parallel, there is no interaction between the two factors, and vice versa.

### ZONE-BUS

In the Zone-Bus interaction plot, there was minimal difference for the DRAC85 between Zone 1 and Zone 2 when no bus exists in the network. Vehicles are travelling at a fairly constant distribution of speed. However, as the percentage of bus increases, there is significant increase of DRAC85 in Zone 1 (Farther from the track) while there is a small decrease in Zone 2 (Closer to the track). The limited storage length in Zone 2 (about 10 m between the stop line and the dividing line of Zone 1 and Zone 2) might explain the relatively constant DRAC85 values. The slight decrease in DRAC85 is probably due to the increased portion of slowing/stopping of vehicle in the time interval when a bus is present. The significant increase of DRAC85 in Zone 1 could indicate the potential spillback of vehicles with an increase in the percentage of buses in the lane. The increase in DRAC85 is especially pronounced in Zone 1 since this is the segment where buses begin to decelerate prior to stopping at the track.

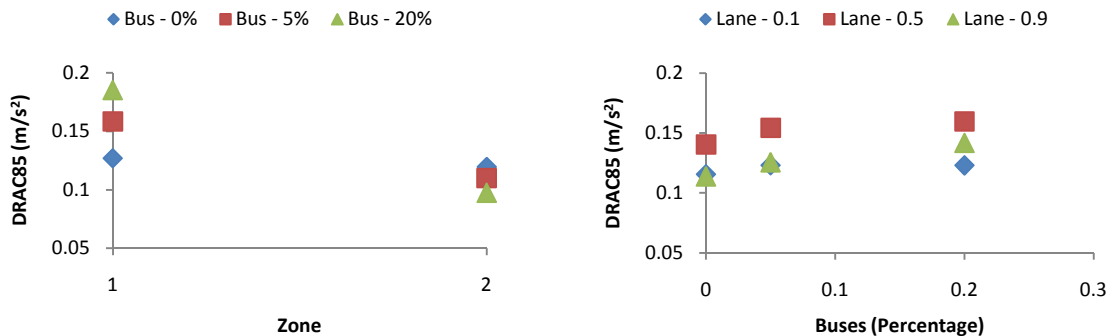

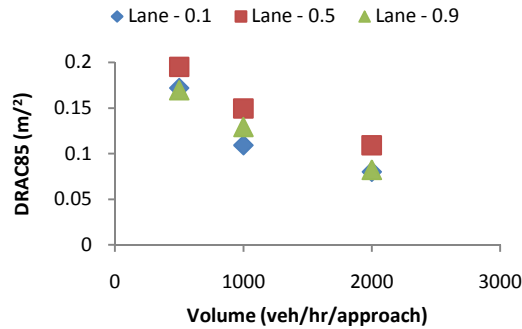

Figure 26 Two-Factor Interaction Effect

### BUS-LANE

In Bus-Lane plot of a lane distribution 50:50, the DRAC85 is significantly higher than for lane distributions 10:90 and 90:10 regardless of the total traffic volume. The overloading of vehicles in lane with 90% car in shoulder/center lane lessens the speed difference between the approaching vehicles, and it accounts for a reduction in DRAC85. This result was also obtained for the 10:90 lane distributions.

A major difference of DRAC85 between lane distribution 10:90 and 90:10 is especially pronounced for the case of 20% buses. It could be explained by the compounding effect of bus and cars in the shoulder lane. Consistent with previous explanation, the 90% of car in the shoulder lane and the frequent stopping of buses in the shoulder lane dampen speed reduction and increases safety. This implies that the improvement in safety occurs between two percentages of buses cases (5%-20%). There might be a threshold between these two percentage buses classes.

### VOLUME-LANE

In a similar fashion to Bus-Lane, the DRAC85 for a 50:50 lane distribution is significantly higher than for either 10:90 or 90:10 regardless of the percentage of bus.

For a total traffic volume of 500 veh/hr/approach ( $Volume_{500}$ ), there is no difference of DRAC85 between the 10:90 and 90:10 lane distributions. The same observation can be made for a 2000 veh/hr/approach; however, this can be explained in different ways. For a volume of 2000 veh/hr/approach, both center and shoulder lanes are at capacity due to the overloading of vehicles, which lessens the speed difference between the approaching vehicle and the stopped vehicle. At a low traffic volume ( $Volume_{500}$ ), the increase portion of vehicles in the shoulder lane, could be expected to

increase the risk of rear-end interactions. At the same time, there are fewer vehicles in the center lane and fewer interactions. The same explanation could apply for the 90:10 lane distribution and hence, their DRAC85 are expected to be the same.

The significant difference in DRAC85 between 10:90 and 90:10 lane distributions at a volume of 1000 veh/hr/approach is the cause of this interaction effect (all other points are parallel with each other across the level of volume). DRAC85 in a 90:10 lane distribution is greater than that of 10:90 lane distributions. In a 90:10 lane distribution, there is less cars and more risky vehicles interaction in the shoulder lane. On the other hand, in the 10:90 lane distribution, the combination of the stopping of buses and 90% cars in the shoulder overload the link and hence, a lower DRAC8th is observed.

#### **5.4 Case Study – Comparing DRAC to Other Safety Performance Measures**

Different safety performance measures have different underlying assumptions, advantages and drawbacks. This chapter compares three different measures of safety performances with DRAC85th based on an N-way ANOVA procedure. In this comparison, the focus is on following measures: (i) Time to Collision (TTC), (ii) Crash Potential Index (CPI), and (iii) Unsafety. The estimation of these safety performances measures are based on the identical 27 scenarios applied to DRAC.

##### Time to Crash (TTC)

The results of the TTC15 ANOVA test are illustrated in Table 11. The factors that were found to be significant at the 5% level are highlighted in this table. The results demonstrated statistical significance for a number of main effect (single order), two-factor interactions (second order), and three-factor interactions (third order).

Table 11 ANOVA Results based on TTC

Dependent Variable: TTC15					
Source	DF	Type III SS	Mean Square	F Value	Pr > F
Volume	1	0.840	0.840	3.8	0.051
<b>Bus</b>	<b>1</b>	<b>2.434</b>	<b>2.434</b>	<b>11.03</b>	<b>0.001</b>
Volume *Bus	1	0.134	0.134	0.61	0.436
<b>Lane</b>	<b>1</b>	<b>0.930</b>	<b>0.930</b>	<b>4.21</b>	<b>0.040</b>
Volume *Lane	1	0.803	0.803	3.64	0.057
<b>Bus*Lane</b>	<b>1</b>	<b>2.819</b>	<b>2.819</b>	<b>12.77</b>	<b>0.000</b>
Volume *Bus*Lane	1	0.258	0.258	1.17	0.280
<b>Zone</b>	<b>1</b>	<b>6.696</b>	<b>6.696</b>	<b>30.34</b>	<b>&lt;.0001</b>
<b>Volume *Zone</b>	<b>1</b>	<b>1.131</b>	<b>1.131</b>	<b>5.12</b>	<b>0.024</b>
<b>Bus*Zone</b>	<b>1</b>	<b>10.451</b>	<b>10.451</b>	<b>47.35</b>	<b>&lt;.0001</b>
Volume *Bus*Zone	1	0.531	0.531	2.4	0.121
<b>Lane*Zone</b>	<b>1</b>	<b>1.682</b>	<b>1.682</b>	<b>7.62</b>	<b>0.006</b>
<b>Volume *Lane*Zone</b>	<b>1</b>	<b>1.457</b>	<b>1.457</b>	<b>6.6</b>	<b>0.010</b>
<b>Bus*Lane*Zone</b>	<b>1</b>	<b>2.927</b>	<b>2.927</b>	<b>13.26</b>	<b>0.000</b>
Volume *Bus*Lane*Zone	1	0.001	0.001	0.01	0.936

Note:1 Bold item indicated the significance of that specific treatment combination

### Crash Potential Index (CPI)

Assumptions for Maximum Available Deceleration Rate (MADR) were made for different vehicle types and road conditions (Saccomanno, Cunto, Guido, & Vitale, 2008). While cars have a mean of  $8.45 \text{ m}^2$  and trucks have a mean of  $5.01 \text{ m/s}^2$ , both cars and trucks have a braking capability standard deviation of  $1.4 \text{ m/s}^2$  under dry pavement condition. The 85<sup>th</sup> percentile of DRAC has been used as an input to estimate CPI85.

The results of the CPI85 ANOVA test are illustrated in Table 12. The factors that were found to be significant at the 5% level are highlighted in the table. The results demonstrated statistical significance for one main effect (single order) and one two-factor interaction (second order). Two factors were found to be significant at the 5% level: Zone and Bus-Lane.

Table 12 ANOVA Results based on CPI

Dependent Variable: CPI85					
Source	DF	Type III SS	Mean Square	F Value	Pr > F
Vol	1	0.000	0.000	0.720	0.398
Bus	1	0.000	0.000	0.350	0.556
Volume*Bus	1	0.000	0.000	0.030	0.871
Lane	1	2.75E-13	2.75E-13	0.25	0.620
Volume*Lane	1	6.10E-18	6.10E-18	0	0.998
<b>Bus*Lane</b>	<b>1</b>	<b>3.88E-12</b>	<b>3.88E-12</b>	<b>3.47</b>	<b>0.063</b>
Volume*Bus*Lane	1	6.83E-13	6.83E-13	0.61	0.434
<b>Zone</b>	<b>1</b>	<b>1.70E-11</b>	<b>1.70E-11</b>	<b>15.17</b>	<b>0.000</b>
Volume*Zone	1	6.89E-13	6.89E-13	0.62	0.433
Bus*Zone	1	4.24E-17	4.24E-17	0	0.995
Volume*Bus*Zone	1	2.50E-13	2.50E-13	0.22	0.636
Lane*Zone	1	4.62E-13	4.62E-13	0.41	0.521
Volume*Lane*Zone	1	7.63E-15	7.63E-15	0.01	0.934
Bus*Lane*Zone	1	1.49E-12	1.49E-12	1.34	0.248
Volume *Bus*Lane*Zone	1	8.89E-14	8.89E-14	0.08	0.778

Note:<sup>1</sup> Bold item indicated the significance of that specific treatment combination

### Unsafty

Instead of focusing on the DRAC in the following vehicle used in CPI, Unsafty considered the ratio of actual deceleration to maximum deceleration of the lead vehicle. The maximum deceleration is based on the assumption of the mean plus 2 standard deviations used in MADR. Unsafty85 is used to represent the high risk behavior at the 85<sup>th</sup> percentile of all recorded Unsafty values.

The results of the Unsafty85 ANOVA test are illustrated in Table 13. The factors that were found to be significant at the 5% level are highlighted in this table. The results demonstrated statistical significance for a number of main effects (single order), two-factor interactions (second order), and three-factor interactions (third order).

Table 13 ANOVA Results based on UD

Dependent Variable: UNSAFETY85					
Source	DF	Type III SS	Mean Square	F Value	Pr > F
<b>Volume</b>	<b>1</b>	<b>19.988</b>	<b>19.988</b>	<b>921.72</b>	<b>&lt;.0001</b>
<b>Bus</b>	<b>1</b>	<b>16.249</b>	<b>16.249</b>	<b>749.31</b>	<b>&lt;.0001</b>
<b>Volume*Bus</b>	<b>1</b>	<b>3.403</b>	<b>3.403</b>	<b>156.93</b>	<b>&lt;.0001</b>
<b>Lane</b>	<b>1</b>	<b>0.800</b>	<b>0.800</b>	<b>36.89</b>	<b>&lt;.0001</b>
<b>Volume*Lane</b>	<b>1</b>	<b>0.579</b>	<b>0.579</b>	<b>26.69</b>	<b>&lt;.0001</b>
<b>Bus*Lane</b>	<b>1</b>	<b>4.615</b>	<b>4.615</b>	<b>212.81</b>	<b>&lt;.0001</b>
<b>Volume*Bus*Lane</b>	<b>1</b>	<b>0.884</b>	<b>0.884</b>	<b>40.78</b>	<b>&lt;.0001</b>
<b>Zone</b>	<b>1</b>	<b>11.229</b>	<b>11.229</b>	<b>517.8</b>	<b>&lt;.0001</b>
<b>Volume*Zone</b>	<b>1</b>	<b>2.561</b>	<b>2.561</b>	<b>118.08</b>	<b>&lt;.0001</b>
<b>Bus*Zone</b>	<b>1</b>	<b>1.934</b>	<b>1.934</b>	<b>89.18</b>	<b>&lt;.0001</b>
<b>Volume*Bus*Zone</b>	<b>1</b>	<b>0.519</b>	<b>0.519</b>	<b>23.95</b>	<b>&lt;.0001</b>
Lane*Zone	1	0.002	0.002	0.11	0.735
Volume*Lane*Zone	1	0.013	0.013	0.6	0.438
<b>Bus*Lane*Zone</b>	<b>1</b>	<b>0.130</b>	<b>0.130</b>	<b>6.02</b>	<b>0.014</b>
<b>Volume*Bus*Lane*Zone</b>	<b>1</b>	<b>0.094</b>	<b>0.094</b>	<b>4.34</b>	<b>0.037</b>

Note:<sup>1</sup> Bold item indicated the significance of that specific treatment combination

#### 5.4.1 ANOVA Results

A summary of the ANOVA test applied to the four measures of safety performance including DRAC is given in Table 14.

There are noticeable differences of significant terms for the various SP measures. While only 2 terms are significant in the CPI85 ANOVA test, 12 traffic factors (first order, second order, third order) are significant in estimating the change of traffic impact on Unsafty, and 4 traffic factors (first order and second) are significant for TTC. Each safety performance measure uses different traffic operational parameters. And this could explain the main and higher order effects. For example, TTC and DRAC have variables to represent differential speed and headway. CPI considers MADR in addition to differential speed and headway. UD, on the other hand, consider the deceleration from the lead vehicle. Hence, in evaluating countermeasures using simulation models, there is a need to be aware of the underlying biases associates with the use of different measures of safety performances.



Table 14 Significant Terms based on Four-way ANOVA under DRAC, TTC, CPI, UD

<b>Safety Performance (SP) measures</b>	<b>Terms</b>
Deceleration Rate to Avoid a Crash (DRAC) <small>*from Previous Chapter</small>	Main Effect: Volume, Lane, Zone 2-Factor Interaction Effect: Volume*Lane, Bus*Lane, Bus*Zone 3-Factor Interaction Effect: Volume*Bus*Lane, Volume*Bus*Zone, Bus*Lane*Zone
Time to Crash (TTC)	Main Effect: Bus, Lane, Zone 2-Factor Interaction Effect: Bus*Lane, Volume*Zone, Bus*Zone
Crash Potential Index (CPI)	Main Effect: Zone 2-Factor Interaction: Bus-Lane
Unsafety	Main Effect: Volume, Bus, Lane, Zone 2-Factor Interaction Effect: Volume*Bus, Volume*Lane, Bus*Lane, Volume*Zone, Bus*Zone 3-Factor Interaction Effect: Volume*Bus*Lane Volume*Bus*Zone, Bus*Lane*Zone 4-Factor Interaction Effect: Volume*Bus*Lane*Zone

Note: Volume = Total Traffic Volume; Bus = Percentage of bus; Lane = Percentage of car in center lane; ZoneLevel = Zonal effect (closer to the track, upstream section)

The following sections compare DRAC with each of the three safety performance indicators in terms of the differences in significances term in main factor.

### 5.4.2 DRAC VS TTC

According to Figure 27 and Figure 28, the differences in the main effects significant terms are: (i) Total traffic volume is significant in DRAC85 but not in TTC15. (ii) Percentage of buses is significant in TTC15 but not in DRAC85.

There are several assumptions in analyzing the plots. The slopes of data series between the SP measures cannot be compared as each of the SP measures are based on a different scale. For example, an overlapping data series does not imply the changes in risk are of same magnitude. There is no conversion available between the SP values. Hence, the only implication from the slope of data series is the indication of an increase/decrease in risk. The overlapping of data points does not imply the same level of risk.

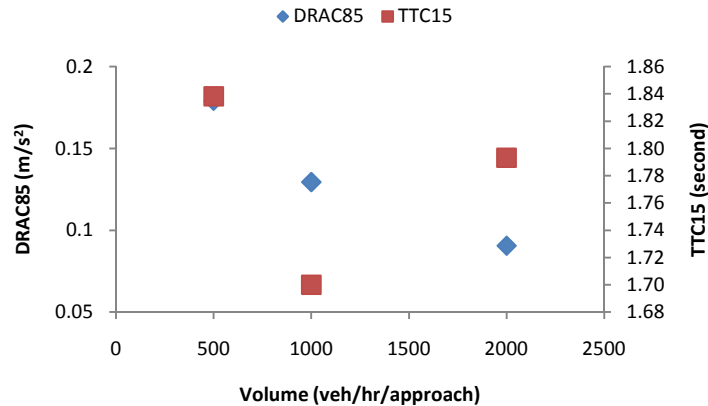

Figure 27 Main Effects - DRAC vs Volume and TTC vs Volume

According to Figure 27, DRAC85 decreases from  $0.18 \text{ m/s}^2$  to  $0.10 \text{ m/s}^2$  when the total traffic volume increases. A smaller deceleration rate indicates a reduction in risk. TTC15 decreases from 1.84 s at a volume of 500 veh/hr/approach to 1.70 s at a volume of 1000 veh/hr/approach. The reduction in time to collision also indicates a high risk. TTC15 then increases again from 1.70 s to 1.79 s when traffic volume increases to 2000 veh/hr/approach and it implies a reduction in risk. The two line series has different pattern and are conveying different messages regarding to risk with respect to change in volume.

Vehicles are closely following each other in high traffic volume. According to the Flow-Speed relationship described in Figure 24, the increase volumes results in lower speed. Hence, the TTC85 at a total traffic volume of 2000 veh/hr/approach is higher than that of 1000 veh/hr/approach. The reduction in speed is dominating the safety performance estimation. As volume increases from 500 veh/hr/approach to 1000 veh/hr/approach, the magnitude of speed reduction could not offset the increase in volume (increase density). The results describe the basic weakness of using TTC as SP measures: Two vehicles that are farther apart and has high differential speed could have the same TTC as vehicles at short distances travelling at lower differential speed. Vehicles travelling at a volume of 500 veh/hr/approach are expected to travel at a higher speed and perceived a higher risk. Although both cases apparently reflect different crash risk, TTC failed to distinguish the 500 veh/hr/approach as a higher risk scenario.

Deceleration Rate to Avoid the Crash (DRAC) describes the rate of following vehicle has to decelerate as a reaction to the lead vehicle. The relationship between DRAC and volume reflects a

reduction in speed associated with the high volume traffic flow. At a lower approaching speed scenario, the deceleration rate required to avoid a crash is apparently lower. Figure 27 reflects his monotonic decrease in risk as volumes increase.

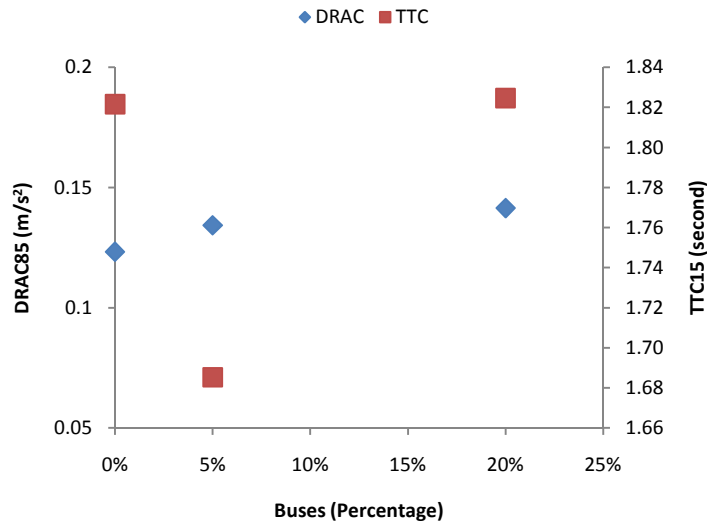

Figure 28 Main Effects - DRAC vs Buses and TTC vs Buses

According to Figure 28, DRAC85 remains relatively constant varying between 0.12 m/s<sup>2</sup> and 0.14 m/s<sup>2</sup> when the percentages of buses increase (increase risk). TTC15 decreases from 1.81 s for 0% of buses to 1.69 s for 5% of buses (increase risk). TTC15 increases again from 1.69 s to 1.82 s when percentages of buses increase to 20% (reduce risk). The two line series are conveying different messages regarding to risk with respect to change in volume.

The pattern of the data series in TTC shown in Figure 28 is similar to one in Figure 27. Since buses are required to stop in Zone 2, the speed reduction effect is similar to one described for “Volume”. At 5% and 20% of buses, the TTC85 values do not have noticeable difference. For a small increase in percentage of buses from 0% to 5%, the volume/speed effect is not as pronounced and hence, there is a reduction in TTC (as illustrated in Figure 28).

For DRAC, the increase in percentage of buses indicates more stopping request for all vehicles entering the zone. Previous section introduces the spillback effect due to the presence of buses. Vehicles in Zone 1 need to react to this traffic interruption and hence, increase their DRAC. The relationship in Figure 28 shows a moderate increase in DRAC with higher percentage of buses.

### 5.4.3 DRAC vs CPI

The differences in the single order factor are the significant of Volume and Lane in DRAC85 but not in CPI85. Data plots had been made for each traffic attributes using the two SP performance measures (Figure 29).

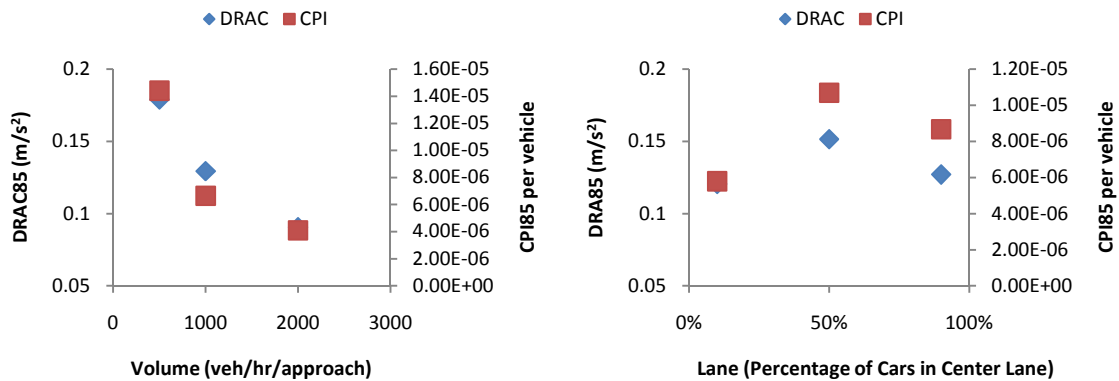

Figure 29 DRAC vs CPI

In Figure 29, a comparison between DRAC and CPI per vehicle indicates a similar relationship with increase volume and higher percentages of cars in center lane, respectively. The percentages of cars in the center lane increase from 10% to 50%, both SP measures indicated an increase in risk (increase in values). When the percentages of cars further increase from 50% to 90%, both SP measures indicated a reduction in risk (decrease in values).

The explanations for the pattern in Volume in Lane with respect to DRAC are discussed in Section 5.3. The major difference between CPI and DRAC is the introduction of variation in braking capability (MADR) for CPI estimation. The simulation results show that MADR is not high enough to pose a major explanatory effect. From this analysis, it can be concluded that DRAC provides a good representation of CPI in analyzing grade crossing safety.

### 5.4.4 DRAC vs UD

The only difference between DRAC85 and Unsafty85 in terms of main effect is the insignificant bus term in DRAC85th. Data series of DRAC85th and Unsafty85 has been plotted against percentage of buses as shown in Figure 30.

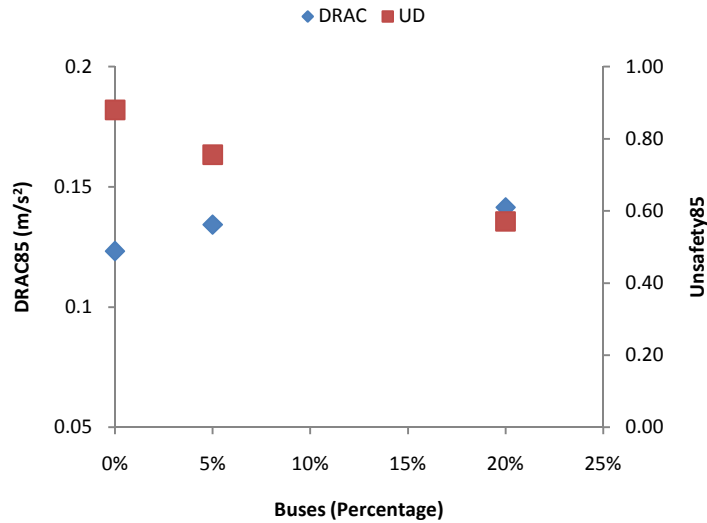

Figure 30 DRAC vs Unsafety

One of the measures in adopting for SP comparison is the 85<sup>th</sup> percentile of Unsafety (Unsafety85) for the traffic stream. A comparison between this measure and DRAC highlights the basic inconsistency. This can illustrate to Figure 30. There is a steady increase in DRAC85 from 0.12 to 0.14 when the percentage of buses rises from 0% to 20%. An increase in DRAC85 indicates more risky situations are expected when the crossing are filled with buses. On the contrary, Unsafety85 decreases from 0.88 to 0.57 when the percentage of buses rises from 0% to 20%. The data series from Unsafety85 indicated a reduction risk as buses are inserted into the network.

As discussed previously, the disruption in traffic stream to which drivers need to adjust is directly proportional to the percentages of buses in the traffic network. Hence, the deceleration rate in upstream section (Zone 1) increases as the percentage of buses increases. Unsafety does not reflect differences in headway between vehicles. This is because the inter-vehicle spacing (headway) is not considered in the expression; whereas for DRAC, the inter-vehicle spacing is expected to be reduced when percentage of buses increases.

#### 5.4.5 Zonal Effects on Safety Performance Measures

Table 15 provides the 85<sup>th</sup> percentile of four SP measures in traffic stream categorized by grade crossing zones where Zone 1 is about 60 m from the track and Zone 2 is 20 m from the track.

Table 15 Zonal Effects on Safety Performance Measures

	Unit	Zone 1	Zone 2	Risk
DRAC85	m <sup>2</sup>	0.157	0.109	Reduce
TTC15	second	2.086	1.469	Increase
CPI85	per vehicle	1.614E-05	6.330E-07	Reduce
Unsafty85	m <sup>3</sup> /s <sup>4</sup>	0.905	0.520	Reduce

The results indicated some inconsistency depending on the SP measures used. The SP measures DRAC, CPI, and UD show that there is an increase in safety for vehicles transversing from Zone 1 to Zone 2. Drivers begin the deceleration procedure in Zone 1 in reaction to warning devices (flashing light and gates) being activated. Hence, Zone2 has lower DRAC, CPI and Unsafty. TTC, on the other hand, indicates a significant increase in risk in Zone 2. The TTC15 in Zone 2 is on the safety margin indicated in Section 3.3.2. Instead of considering on the deceleration attributes like the above SP measures, the spotlight of TTC is the differential speed and spacing in Zone 2. Since Zone 2 is a small area, which reflects a shorter distance that drivers can react, there is a spike in TTC measurements in that area.

There are some contradictions between the speed profile for an open crossing by zones and the deceleration observations taking place in Zone 1 when gate is taken into consideration. The previous study indicates an increase in risk when no bus or train activity present in the crossing. The analysis in Chapter 5, however, indicated an improvement in safety in locations where vehicles are closer to the track. In fact, there is no contradiction. For an open crossing, the drivers are subject to the reduce speed requirement of crossing the track which infer to a higher deceleration in Zone 2. However, when a train is present, gates are activated. Vehicles will begin to reduce their speed further upstream. Hence, higher DRAC values in Zone 1 are observed.

## Chapter 6

### Conclusions and Recommendations

There are several conclusions that can be drawn from this thesis.

- 1) A microscopic traffic simulation approach has the potential to reveal specific causal relationship that could affect safety at grade crossing, otherwise that would not be possible from the traditional statistical methods.
- 2) Drivers behave in a unique way in the vicinity of a crossing and this behavior is not necessary affected by the presence of a train or the nature of the warning devices. Grade crossing safety needs to be viewed in a bi-zonal context because the behavior of vehicles near the track differs from those further away from the track as indicated in the preliminary speed reduction study (Section 3.2.1).
  - a. In the absence of a train, vehicles tend to reduce their speed in the vicinity of a crossing. Much of this reduction in speed tends to occur in the vicinity of the track itself. This reduction in speed results in traffic flow turbulence that increases the opportunity for high risk rear-end vehicle interactions. Hence, an additional risk is introduced in the vicinity of a crossing.
  - b. Distance to the track has a calming effect on the traffic disruption indicated above such that with distance to the track, the reduction in speed is less pronounced, again in the absence of a train.
    - i. The presence of a train at an active crossing advise drivers that vehicles ahead could be stopping and hence they will adjust their speed accordingly. This behaviors result in an unexpected, yet disruptive, reduction in speed with corresponding improvement in safety (rear-end vehicle interactions).
    - ii. The presence of a train at an active crossing has a spillback effect on the speed profile of vehicles entering the crossing environment. Decelerating vehicles near the track force vehicles further from the track also reduce their speed, but this is done in a more moderate manner way. The result is a small increase in risk (vehicles interactions) at greater distance from the track.

- 3) A number of factors were found to affect the behavior of vehicles in the grade crossing environment. In this thesis, the focus has been on three basic factors: (i) Percentage of buses in the shoulder lane, (ii) Total traffic volume, and (iii) Percentage of vehicles in the center lane.
  - a. As the percentage of buses in the shoulder lane increases, assuming the buses are required to stop near the track, vehicle interactions for the grade crossing increases. The bulk of the disruption, however, takes place at greater distances from the crossing (Zone 1) since Zone 2, as defined in the thesis, is too short. The presence of buses has a spillback effect on rear-end vehicles risk, the higher the percentages of buses, the greater the spillback effect becomes, and this does not withstand the presence of a train. In the thesis, the assumption has been restricted to the shoulder lane.
  - b. The percentage of vehicles in the center lane has the greatest effect on increasing the risk when vehicles are equally distributed among the lanes. In those cases, when most of the vehicles occupy one of the lanes, the effect of increase percentage has the same effect of increasing the traffic volume, i.e. vehicles are moving slower hence vehicle interactions take place at lower differential speed.
  - c. Closely related to (b), increasing total traffic volume reduces the speed reduction associated with the crossing. The reason for this is due to congestion and its resultant lower speeds. This result takes place regardless of zonal segmentation (no significant Volume-Zone interaction effect).
- 4) A number of surrogate safety measures of safety performance have been considered with respect to factors affecting safety: (i) DRAC, (ii) TTC, (iii) CPI/veh, and (iv) Unsafety. Of the above, DRAC seems to provide the best indication of rear-end vehicle interaction problems. CPI/veh does not differ much from DRAC, and TTC, whilst Unsafety have inherit structural problems with the measures (for TTC, high speed – high spacing / low speed – low spacing distinction; for Unsafety, no spacing considered).
- 5) DRAC seems to reflect problems with rear-end vehicle interactions in the vicinity of a crossing as a function of the mitigating factors considered in this research (as discussed in 3). CPI/veh and Unsafety are consistent with DRAC, which suggest a higher risk (rear-end) in Zone 1 compared to Zone 2. The exception is TTC and this is due to its failure to consider specific vehicle deceleration rates.



## 6.1 Recommendation

- 1) While the results suggest promising application of microscopic simulation for analyzing grade crossing safety, this work has been rather preliminary in nature. Clearly, there is a need for a more thorough calibration for a microscopic traffic simulation with respect to a wider range of geometric traffic conditions. The videotaping of a single case study of a crossing is not representative enough.
- 2) The accuracy of the videotaping exercise has not been fully established at a finer level of special specification to have confidence in these results. A higher resolution vehicle tracking data set needs to be collected with 0.1 second interval.
- 3) A larger number of grade crossings are not gate equipped. It would be interesting to extend the application of the microscopic simulation approach to include other type of warning devices such as flashing lights only crossing, passive crossings, and the use of four quadrant gates.
- 4) This study makes use of a VISSIM traffic simulation platform because the model developer has been making efforts to incorporate grade crossing into their simulation logic. Other platforms could be used and may provide similar or better results.

**Appendix A**  
**Transportation Microsimulation Models Theory History and**  
**Implementation Snapshot by Model Type**



**Appendix B**  
**SPSS for Signal Control**

GET

```
FILE='N:\SPSS VISSIM\Singal Control Parameter Estimate.sav'.  
LOGISTIC REGRESSION VARIABLES DidItCross  
/METHOD=ENTER VelWhenBellStartRing DistFrStopLine  
/CLASSPLOT  
/CASEWISE OUTLIER(2)  
/PRINT=GOODFIT CORR ITER(1) CI(95)  
/CRITERIA=PIN(0.05) POUT(0.10) ITERATE(20) CUT(0.5).
```

## Logistic Regression

### Notes

	Output Created	07-Dec-2009 13:33:15
	Comments	
Input	Data	N:\SPSS VISSIM\Singal Control Parameter Estimate.sav
	Active Dataset	DataSet1
	Filter	<none>
	Weight	<none>
	Split File	<none>
	N of Rows in Working Data File	34
Missing Value Handling	Definition of Missing	User-defined missing values are treated as missing
	Syntax	LOGISTIC REGRESSION VARIABLES DidItCross /METHOD=ENTER VelWhenBellStartRing DistFrStopLine /CLASSPLOT /CASEWISE OUTLIER(2) /PRINT=GOODFIT CORR ITER(1) CI(95) /CRITERIA=PIN(0.05) POUT(0.10) ITERATE(20) CUT(0.5).
Resources	Processor Time	0:00:00.031
	Elapsed Time	0:00:00.063

[DataSet1] N:\SPSS VISSIM\Singal Control Parameter Estimate.sav

### Case Processing Summary

Unweighted Cases <sup>a</sup>		N	Percent
Selected Cases	Included in Analysis	34	100.0
	Missing Cases	0	.0
	Total	34	100.0

a. If weight is in effect, see classification table for the total number of cases.

**Case Processing Summary**

Unweighted Cases <sup>a</sup>	N	Percent
Unselected Cases	0	.0
Total	34	100.0

a. If weight is in effect, see classification table for the total number of cases.

**Dependent Variable Encoding**

Original Value	Internal Value
0	0
1	1

**Block 0: Beginning Block**

**Iteration History<sup>a,b,c</sup>**

Iteration		Coefficients	
		-2 Log likelihood	Constant
Step 0	1	46.662	.235
	2	46.662	.236
	3	46.662	.236

a. Constant is included in the model.

b. Initial -2 Log Likelihood: 46.662

c. Estimation terminated at iteration number 3 because parameter estimates changed by less than .001.

**Classification Table<sup>a,b</sup>**

Observed			Predicted		
			DidItCross		Percentage Correct
			0	1	
Step 0	DidItCross	0	0	15	.0
		1	0	19	100.0
Overall Percentage					55.9

a. Constant is included in the model.

b. The cut value is .500

**Variables in the Equation**

	B	S.E.	Wald	df	Sig.	Exp(B)
Step 0 Constant	.236	.345	.468	1	.494	1.267

Contingency Table for Hosmer and Lemeshow Test

		DdItCross = 0		DdItCross = 1		Total
		Observed	Expected	Observed	Expected	
Step 1	1	3	2.996	0	.004	3
	2	3	2.968	0	.032	3
	3	3	2.760	0	.260	3
	4	2	2.562	1	.438	3
	5	3	2.232	0	.768	3
	6	1	1.348	2	1.652	3
	7	0	.111	3	2.889	3
	8	0	.027	3	2.973	3
	9	0	.007	3	2.993	3
	10	0	.000	7	7.000	7

Classification Table<sup>a</sup>

Observed		Predicted		
		DdItCross		Percentage Correct
		0	1	
Step 1	DdItCross	0	1	
		14	1	93.3
		3	16	84.2
	Overall Percentage			88.2

a. The cut value is .500

Variables in the Equation

		B	S.E.	Wald	df	Sig.	Exp(B)
Step 1 <sup>a</sup>	VelWhenBellStartRing	-.359	.241	2.215	1	.137	.698
	DistFrStopLine	.125	.056	5.048	1	.025	1.133
	Constant	-.431	2.816	.023	1	.878	.650

a. Variable(s) entered on step 1: VelWhenBellStartRing, DistFrStopLine.

Variables in the Equation

		95% C.I. for EXP(B)	
		Lower	Upper
Step 1 <sup>a</sup>	VelWhenBellStartRing	.435	1.121
	DistFrStopLine	1.016	1.264

a. Variable(s) entered on step 1: VelWhenBellStartRing, DistFrStopLine.

Correlation Matrix

		Constant	VelWhenBellStartRing	DistFrStopLine
Step 1	Constant	1.000	-.749	.034
	VelWhenBellStartRing	-.749	1.000	-.661

**Variables not in the Equation**

			Score	df	Sig.
Step 0	Variables	VelWhenBellStartRing	4.239	1	.040
		DistFrStopLine	14.959	1	.000
		Overall Statistics	16.600	2	.000

**Block 1: Method = Enter**

**Iteration History<sup>a,b,c,d</sup>**

Iteration		-2 Log likelihood	Coefficients		
			Constant	VelWhenBell StartRing	DistFrStop Line
Step 1	1	26.919	-.030	-.078	.019
	2	19.332	-.035	-.143	.039
	3	15.021	-.391	-.202	.067
	4	13.438	-.625	-.264	.094
	5	13.059	-.597	-.321	.114
	6	13.017	-.471	-.353	.123
	7	13.016	-.433	-.359	.125
	8	13.016	-.431	-.359	.125
	9	13.016	-.431	-.359	.125

a. Method: Enter

b. Constant is included in the model.

c. Initial -2 Log Likelihood: 46.662

d. Estimation terminated at iteration number 9 because parameter estimates changed by less than .001.

**Omnibus Tests of Model Coefficients**

		Chi-square	df	Sig.
Step 1	Step	33.647	2	.000
	Block	33.647	2	.000
	Model	33.647	2	.000

**Model Summary**

Step	-2 Log likelihood	Cox & Snell R Square	Nagelkerke R Square
1	13.016 <sup>a</sup>	.628	.842

a. Estimation terminated at iteration number 9 because parameter estimates changed by less than .001.

**Hosmer and Lemeshow Test**

Step	Chi-square	df	Sig.
1	2.497	8	.962



**Appendix C**  
**Data Extraction Procedures**

## Data Extraction Flow Chart

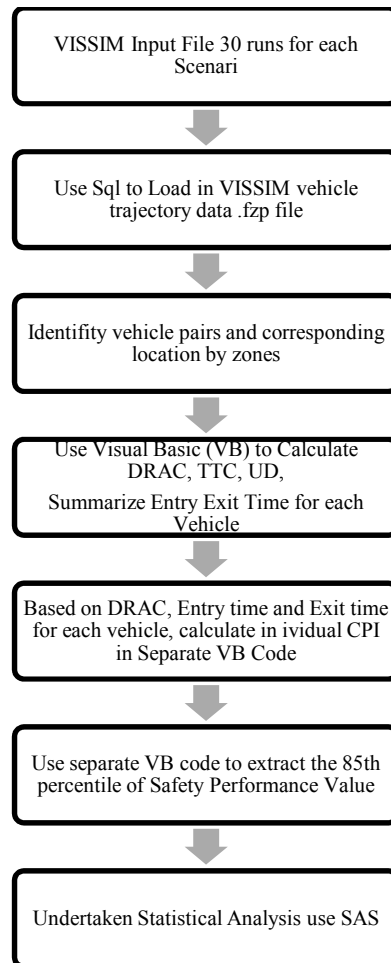

## Partial fzp Output File for Scenario 1

Vehicle Record

File: D:\VISSIM\_January\SI1Test8\_.inp  
 Comment:  
 Date: June-02-10 12:24:18 AM  
 VISSIM: 5.10-11 [21194]

VehNr: Number of the Vehicle  
 t: Simulation Time [s]  
 Link: Number of the Active Link  
 x: Link Coordinate [m] at the end of the simulation step  
 Lane: Number of the Active Lane  
 IVeh: Number of the relevant leading vehicle that determines the following behavior  
 LVEh: Number of the next vehicle downstream  
 vMS: Speed [m/s] at the end of the simulation step  
 dvMS: Speed relative to the relevant leading vehicle [m/s] before the simulation step (>0 = faster)  
 Head: Headway to the next vehicle downstream [m] before the simulation step  
 Length: Length [m]  
 Type: Number of the Vehicle Type  
 LCh: Direction of current lane change  
 a: Acceleration [m/s<sup>2</sup>] during the simulation step  
 Route: Route number  
 RoutDec: Routing decision number

VehNr;	t;	Link;	x;	Lane;	IVeh;	LVEh;	vMS;	dvMS;	Head;	Length;	Type;	LCh;	a;	Route;	RoutDec;
3;	2.8;	20;	0.3;	1;	-40;	-40;	10.23;	10.21;	167.4;	4.8;	100;	-;	0.20;	0;	0;
3;	2.9;	20;	1.4;	1;	-40;	-40;	10.25;	10.23;	166.4;	4.8;	100;	-;	0.25;	0;	0;
3;	3.0;	20;	2.4;	1;	-40;	-40;	10.28;	10.25;	165.4;	4.8;	100;	-;	0.25;	0;	0;
3;	3.1;	20;	3.4;	1;	-40;	-40;	10.30;	10.28;	164.3;	4.8;	100;	-;	0.25;	0;	0;
3;	3.2;	20;	4.4;	1;	-40;	-40;	10.33;	10.30;	163.3;	4.8;	100;	-;	0.25;	0;	0;
3;	3.3;	20;	5.5;	1;	-40;	-40;	10.35;	10.33;	162.3;	4.8;	100;	-;	0.25;	0;	0;
3;	3.4;	20;	6.5;	1;	-40;	-40;	10.38;	10.35;	161.2;	4.8;	100;	-;	0.25;	0;	0;
3;	3.5;	20;	7.6;	1;	-40;	-40;	10.40;	10.38;	160.2;	4.8;	100;	-;	0.25;	0;	0;
3;	3.6;	20;	8.6;	1;	-40;	-40;	10.43;	10.40;	159.2;	4.8;	100;	-;	0.25;	0;	0;
3;	3.7;	20;	9.6;	1;	-40;	-40;	10.45;	10.43;	158.1;	4.8;	100;	-;	0.25;	0;	0;
3;	3.8;	20;	10.7;	1;	-40;	-40;	10.48;	10.45;	157.1;	4.8;	100;	-;	0.25;	0;	0;
3;	3.9;	20;	11.7;	1;	-40;	-40;	10.50;	10.48;	156.0;	4.8;	100;	-;	0.25;	0;	0;
3;	4.0;	20;	12.8;	1;	-40;	-40;	10.53;	10.50;	155.0;	4.8;	100;	-;	0.25;	0;	0;
3;	4.1;	20;	13.8;	1;	-40;	-40;	10.55;	10.53;	153.9;	4.8;	100;	-;	0.25;	0;	0;
3;	4.2;	20;	14.9;	1;	-40;	-40;	10.58;	10.55;	152.9;	4.8;	100;	-;	0.25;	0;	0;
3;	4.3;	20;	16.0;	1;	-40;	-40;	10.60;	10.58;	151.8;	4.8;	100;	-;	0.25;	0;	0;
3;	4.4;	20;	17.0;	1;	-40;	-40;	10.63;	10.60;	150.8;	4.8;	100;	-;	0.25;	0;	0;
3;	4.5;	20;	18.1;	1;	-40;	-40;	10.65;	10.63;	149.7;	4.8;	100;	-;	0.25;	0;	0;
3;	4.6;	20;	19.1;	1;	-40;	-40;	10.68;	10.65;	148.6;	4.8;	100;	-;	0.25;	0;	0;
3;	4.7;	20;	20.2;	1;	-40;	-40;	10.70;	10.68;	147.6;	4.8;	100;	-;	0.25;	0;	0;
3;	4.8;	20;	21.3;	1;	-40;	-40;	10.73;	10.70;	146.5;	4.8;	100;	-;	0.25;	0;	0;
3;	4.9;	20;	22.4;	1;	-40;	-40;	10.75;	10.73;	145.4;	4.8;	100;	-;	0.25;	0;	0;
3;	5.0;	20;	23.4;	1;	-40;	-40;	10.78;	10.75;	144.4;	4.8;	100;	-;	0.25;	0;	0;
3;	5.1;	20;	24.5;	1;	-40;	-40;	10.80;	10.78;	143.3;	4.8;	100;	-;	0.25;	0;	0;
3;	5.2;	20;	25.6;	1;	-40;	-40;	10.83;	10.80;	142.2;	4.8;	100;	-;	0.25;	0;	0;
3;	5.3;	20;	26.7;	1;	-40;	-40;	10.85;	10.83;	141.1;	4.8;	100;	-;	0.25;	0;	0;
3;	5.4;	20;	27.8;	1;	-40;	-40;	10.88;	10.85;	140.0;	4.8;	100;	-;	0.25;	0;	0;
3;	5.5;	20;	28.9;	1;	-40;	-40;	10.90;	10.88;	138.9;	4.8;	100;	-;	0.25;	0;	0;
3;	5.6;	20;	29.9;	1;	-40;	-40;	10.93;	10.90;	137.9;	4.8;	100;	-;	0.25;	0;	0;
3;	5.7;	20;	31.0;	1;	-40;	-40;	10.95;	10.93;	136.8;	4.8;	100;	-;	0.25;	0;	0;
3;	5.8;	20;	32.1;	1;	-40;	-40;	10.98;	10.95;	135.7;	4.8;	100;	-;	0.25;	0;	0;
3;	5.9;	20;	33.2;	1;	-40;	-40;	11.00;	10.98;	134.6;	4.8;	100;	-;	0.25;	0;	0;
3;	6.0;	20;	34.3;	1;	-40;	-40;	11.01;	11.00;	133.5;	4.8;	100;	-;	0.05;	0;	0;
3;	6.1;	20;	35.4;	1;	-40;	-40;	10.99;	11.01;	132.4;	4.8;	100;	-;	-0.15;	0;	0;
3;	6.2;	20;	36.5;	1;	-40;	-40;	10.97;	10.99;	131.3;	4.8;	100;	-;	-0.25;	0;	0;
3;	6.3;	20;	37.6;	1;	-40;	-40;	10.94;	10.97;	130.2;	4.8;	100;	-;	-0.25;	0;	0;
3;	6.4;	20;	38.7;	1;	-40;	-40;	10.92;	10.94;	129.1;	4.8;	100;	-;	-0.25;	0;	0;
3;	6.5;	20;	39.8;	1;	-40;	-40;	10.89;	10.92;	128.0;	4.8;	100;	-;	-0.25;	0;	0;
3;	6.6;	20;	40.9;	1;	-40;	-40;	10.87;	10.89;	126.9;	4.8;	100;	-;	-0.25;	0;	0;
3;	6.7;	20;	42.0;	1;	-40;	-40;	10.84;	10.87;	125.8;	4.8;	100;	-;	-0.25;	0;	0;
3;	6.8;	20;	43.1;	1;	-40;	-40;	10.82;	10.84;	124.7;	4.8;	100;	-;	-0.25;	0;	0;
3;	6.9;	20;	44.2;	1;	-40;	-40;	10.79;	10.82;	123.6;	4.8;	100;	-;	-0.25;	0;	0;
3;	7.0;	20;	45.2;	1;	-40;	-40;	10.77;	10.79;	122.6;	4.8;	100;	-;	-0.25;	0;	0;
3;	7.1;	20;	46.3;	1;	-40;	-40;	10.74;	10.77;	121.5;	4.8;	100;	-;	-0.25;	0;	0;
3;	7.2;	20;	47.4;	1;	-40;	-40;	10.72;	10.74;	120.4;	4.8;	100;	-;	-0.25;	0;	0;
3;	7.3;	20;	48.4;	1;	-40;	-40;	10.69;	10.72;	119.3;	4.8;	100;	-;	-0.25;	0;	0;
3;	7.4;	20;	49.5;	1;	-40;	-40;	10.67;	10.69;	118.3;	4.8;	100;	-;	-0.25;	0;	0;
3;	7.5;	20;	50.6;	1;	-40;	-40;	10.64;	10.67;	117.2;	4.8;	100;	-;	-0.25;	0;	0;
3;	7.6;	20;	51.6;	1;	-40;	-40;	10.62;	10.64;	116.1;	4.8;	100;	-;	-0.25;	0;	0;
3;	7.7;	20;	52.7;	1;	-40;	-40;	10.59;	10.62;	115.1;	4.8;	100;	-;	-0.25;	0;	0;

## ScreenCapture of SQL output

The screenshot shows the HeidiSQL interface with a query window open. The query is as follows:

```

1 select *
2 from vissim_raw_data
3 where scenarionum = 1 and runnum = 0
4 and time >= 60.0
5 and ((link = 9 and x <= 85.0 and x >= 21.0) or (link = 19 and x <= 83.0 and x >= 21.0))
6 and vehicleNumber = 13
7 order by time;
    
```

The output shows 53 rows of data. The first few rows are summarized below:

filename	ScenarioNum	RunNum	VehicleNumber	Time	Link	x	Lane	IVeh	LVeh	vMS	dyMS	Head	Length	Type	LCh	a	Route	RouteDec
D:\VISSIM_January\Test8\VISSIM\SI\SI\Test8_fzp	1	0	13	67.3	9	21.7	1	-42	-42	12.56	12.58	58.5	4.4	100	-	-0.25	0	
D:\VISSIM_January\Test8\VISSIM\SI\SI\Test8_fzp	1	0	13	67.4	9	22.9	1	-42	-42	12.53	12.53	57.2	4.4	100	-	-0.25	0	
D:\VISSIM_January\Test8\VISSIM\SI\SI\Test8_fzp	1	0	13	67.5	9	24.2	1	-42	-42	12.51	12.53	56	4.4	100	-	-0.25	0	
D:\VISSIM_January\Test8\VISSIM\SI\SI\Test8_fzp	1	0	13	67.6	9	25.4	1	-42	-42	12.48	12.51	54.7	4.4	100	-	-0.25	0	
D:\VISSIM_January\Test8\VISSIM\SI\SI\Test8_fzp	1	0	13	67.7	9	26.7	1	-42	-42	12.46	12.48	53.5	4.4	100	-	-0.25	0	
D:\VISSIM_January\Test8\VISSIM\SI\SI\Test8_fzp	1	0	13	67.8	9	27.9	1	-42	-42	12.43	12.46	52.2	4.4	100	-	-0.25	0	
D:\VISSIM_January\Test8\VISSIM\SI\SI\Test8_fzp	1	0	13	67.9	9	29.2	1	-42	-42	12.43	12.43	51	4.4	100	-	-0.05	0	
D:\VISSIM_January\Test8\VISSIM\SI\SI\Test8_fzp	1	0	13	68	9	30.4	1	-42	-42	12.44	12.43	49.8	4.4	100	-	0.15	0	
D:\VISSIM_January\Test8\VISSIM\SI\SI\Test8_fzp	1	0	13	68.1	9	31.7	1	-42	-42	12.44	12.44	48.5	4.4	100	-	0	0	
D:\VISSIM_January\Test8\VISSIM\SI\SI\Test8_fzp	1	0	13	68.2	9	32.9	1	-42	-42	12.44	12.44	47.3	4.4	100	-	0	0	
D:\VISSIM_January\Test8\VISSIM\SI\SI\Test8_fzp	1	0	13	68.3	9	34.1	1	-42	-42	12.44	12.44	46	4.4	100	-	0	0	
D:\VISSIM_January\Test8\VISSIM\SI\SI\Test8_fzp	1	0	13	68.4	9	35.4	1	-42	-42	12.44	12.44	44.8	4.4	100	-	0	0	
D:\VISSIM_January\Test8\VISSIM\SI\SI\Test8_fzp	1	0	13	68.5	9	36.6	1	-42	-42	12.44	12.44	43.5	4.4	100	-	0	0	
D:\VISSIM_January\Test8\VISSIM\SI\SI\Test8_fzp	1	0	13	68.6	9	37.9	1	-42	-42	12.44	12.44	42.3	4.4	100	-	0	0	
D:\VISSIM_January\Test8\VISSIM\SI\SI\Test8_fzp	1	0	13	68.7	9	39.1	1	-42	-42	12.44	12.44	41	4.4	100	-	0	0	
D:\VISSIM_January\Test8\VISSIM\SI\SI\Test8_fzp	1	0	13	68.8	9	40.4	1	-42	-42	12.44	12.44	39.8	4.4	100	-	0	0	
D:\VISSIM_January\Test8\VISSIM\SI\SI\Test8_fzp	1	0	13	68.9	9	41.6	1	-42	-42	12.44	12.44	38.6	4.4	100	-	0	0	
D:\VISSIM_January\Test8\VISSIM\SI\SI\Test8_fzp	1	0	13	69	9	42.9	1	-42	-42	12.44	12.44	37.3	4.4	100	-	0	0	
D:\VISSIM_January\Test8\VISSIM\SI\SI\Test8_fzp	1	0	13	69.1	9	44.1	1	-42	-42	12.44	12.44	36.1	4.4	100	-	0	0	
D:\VISSIM_January\Test8\VISSIM\SI\SI\Test8_fzp	1	0	13	69.2	9	45.3	1	-42	-42	12.44	12.44	34.8	4.4	100	-	0	0	
D:\VISSIM_January\Test8\VISSIM\SI\SI\Test8_fzp	1	0	13	69.3	9	46.6	1	-42	-42	12.44	12.44	33.6	4.4	100	-	0	0	
D:\VISSIM_January\Test8\VISSIM\SI\SI\Test8_fzp	1	0	13	69.4	9	47.8	1	-42	-42	12.44	12.44	32.3	4.4	100	-	0	0	
D:\VISSIM_January\Test8\VISSIM\SI\SI\Test8_fzp	1	0	13	69.5	9	49.1	1	-42	-42	12.44	12.44	31.1	4.4	100	-	0	0	
D:\VISSIM_January\Test8\VISSIM\SI\SI\Test8_fzp	1	0	13	69.6	9	50.3	1	-42	-42	12.44	12.44	29.8	4.4	100	-	0	0	
D:\VISSIM_January\Test8\VISSIM\SI\SI\Test8_fzp	1	0	13	69.7	9	51.6	1	-42	-42	12.44	12.44	28.6	4.4	100	-	0	0	
D:\VISSIM_January\Test8\VISSIM\SI\SI\Test8_fzp	1	0	13	69.8	9	52.8	1	-42	-42	12.44	12.44	27.4	4.4	100	-	0	0	
D:\VISSIM_January\Test8\VISSIM\SI\SI\Test8_fzp	1	0	13	69.9	9	54.1	1	-42	-42	12.44	12.44	26.1	4.4	100	-	0	0	

The interface also shows the following SQL commands in the bottom panel:

```

47 SHOW PROCEDURE STATUS WHERE `Db`='mydb';
48 SHOW TRIGGERS FROM `mydb`;
49 SHOW EVENTS FROM `mydb`;
50 select * from vissim_raw_data where scenarionum = 1 and runnum = 0 and time >= 60.0 and ((link = 9 and x <= 85.0 and x >= 21.0) or (link = 19 and x <= 83.0 and x >= 21.0)) and
    
```

At the bottom of the window, the status bar shows: 7:15 Connected:00:09:47 MySQL 5.1.47 Uptime:00:09:52 Ready.

## Visual Basic Code to Generate DRAC, TTC, UD, Entry ExitTime

'Goal: Calculate TTC, DRAC, UD

'Input: Use the vehicle pair identified from SQL Database

Imports System.IO

Imports MySql.Data.MySqlClient

Module GateTest9

Dim VehCountT As New Hashtable

Dim TotalCol As Integer = 15

Dim TotRow As Integer = 0

Dim RawArray(TotalCol, 0) As Single

Dim InputArrayFile As StreamWriter

Dim num1 As Integer

Dim num2 As Integer

Dim num3 As Integer

Dim num4 As Integer

Dim num5 As Integer

Dim num6 As Integer

Dim SBThInCar As Integer

Dim SBThOutCar As Integer

Dim SBThInBus As Integer

Dim SBThOutBus As Integer

Dim SBThInHGV As Integer

Dim SBThOutHGV As Integer

Dim VehArray(1) As Single

Dim VehTot As Integer

'Veh #

Dim DRACFileS() As String = {"NA", "In\_1\_Z1", "In\_1\_Z2", "Out\_1\_Z1", "Out\_1\_Z2", "In\_2\_Z1", "In\_2\_Z2", "Out\_2\_Z1", "Out\_2\_Z2", "  
", "In\_3\_Z1", "In\_3\_Z2", "Out\_3\_Z1", "Out\_3\_Z2", "In\_4\_Z1", "In\_4\_Z2", "  
", "Out\_4\_Z1", "Out\_4\_Z2", "In\_5\_Z1", "In\_5\_Z2", "Out\_5\_Z1", "Out\_5\_Z2"}

Dim TimeIn() As Single = {60.0, 984.0, 997.0, 1032.3, 1038}

Dim TimeOut() As Single = {60.0, 984.0, 992.0, 1034.0, 1038.0}

'dracfiles() In\_1\_Z1 -> inner lane, stage 1, zone 1

Dim Place1 As String = ""

Dim Place2 As String = ""

Dim Place3 As String = ""

Dim DRACName As String = Place1 & "\_" & Place2 & "\_" & Place3

Dim TTCName As String = Place1 & "\_" & Place2 & "\_" & Place3

Dim entrynum(20) As Integer

Dim StorageFolder As String

Dim FZPFolder As String

Dim LeadVehNum, LeadT, LeadLink, LeadX, LeadLane, LeadIVeh, LeadLVeh, LeadV, "  
LeadDV, LeadH, LeadL, LeadType, LeadLCH, LeadA, LeadRoute, LeadRDec As Single

Dim dbConnString As String = "Server=localhost;Uid=root;Database=mydb;Port=3306;Pwd=password;"

Dim sql As String = "SELECT \* FROM vissim\_raw\_data WHERE scenarionum=@ScenarioNum " + "  
"and ((link = 9 and x <= 85.0 and x >= 21.0) or (link = 19 and x <= 83.0 and x >= 21.0)) " + "  
"and runnum=@RunNum " + "  
"and time >= 60.0 " + "  
"order by time"

Sub Main()

Dim filterSingleVehicleInTime As Boolean = False 'If set to false, program will load vehicle to RawArray even if it is the only vehicle in that time

Dim ScenarioStartNum As Integer = 27 'From 1 to 27

Dim ScenarioEndNum As Integer = 27

Dim StartRun As Integer = 27 'From 1 to 30

Dim EndRun As Integer = 30

For CurrentScenario As Integer = ScenarioStartNum To ScenarioEndNum

    'If CurrentScenario = 4 Then

        ' StartRun = 23

    'Else

        ' StartRun = 1

```

' End If
For CurrentRun As Integer = StartRun To EndRun
'Storage Folder
StorageFolder = "D:\VISSIM_January\Test9Link\S" & CurrentScenario & "_Test9\"

'Create DRAC files
GenerateDRACFiles(StorageFolder, CurrentScenario, CurrentRun)

' Load data into RawArray
Dim startTime As Date = System.DateTime.Now()
RunAnalysisFor(StorageFolder, CurrentScenario, CurrentRun)
Dim endTime As Date = System.DateTime.Now()
Console.WriteLine("Time took to analyze data for Scenario " & CurrentScenario & " Run " & CurrentRun & " = " &
endTime.Subtract(startTime).ToString())
Next
Next

Console.Write("Finished...press enter to quit")
Console.In.ReadLine()
End Sub

Private Sub RunAnalysisFor(ByVal StorageFolder As String, ByVal CurrentScenario As Integer, ByVal CurrentRun As Integer)
Dim VehicleEntryExitTable As Hashtable = New Hashtable()

Dim conn As MySqlConnection = Nothing
Try
conn = New MySqlConnection(dbConnString)
conn.Open()

Dim cmd As MySqlCommand = New MySqlCommand(sql, conn)
cmd.Parameters.AddWithValue("@ScenarioNum", CurrentScenario)
cmd.Parameters.AddWithValue("@RunNum", CurrentRun - 1)

Console.WriteLine("Querying databae for Scenario " & CurrentScenario & " Run " & CurrentRun & "...")
Dim startTime As Date = System.DateTime.Now()
Dim rdr As MySqlDataReader = cmd.ExecuteReader()
Dim endTime As Date = System.DateTime.Now()
Console.WriteLine(" took " & endTime.Subtract(startTime).ToString())

'Col0: VehNr
'Col1: t
'Col2: Link
'Col3:x
'Col4:lane
'Col5:IVeh
'Col6:L Veh
'Col7:v
'Col8:dv
'Col9:head
'Col10:Length
'Col11:Type
'Col12:LCh
'Col13:a
'Col14: Route #
'Col15: Route Decision #

Dim rowTable As Hashtable = New Hashtable()
Dim lastTime As Double
Dim currentTime As Double

Dim cnt As Integer = 1
While (rdr.HasRows And rdr.Read())
If cnt Mod 10000 = 0 Then
System.Console.WriteLine("scenNum_" & CurrentScenario & ";CurrentRun_" & CurrentRun & "_Reading line #" & cnt & ": " &
Now())
End If

Dim VehicleNum As Integer = rdr.GetInt32(3) 'Col0: VehNr <-----

```

```

Dim Time As Double = rdr.GetDouble(4) 'Col1: t <-----
Dim Link As Integer = rdr.GetInt32(5) 'Col2: Link
Dim x As Double = rdr.GetDouble(6) 'Col3:x
Dim Lane As Integer = rdr.GetInt32(7) 'Col4:lane
Dim IVeh As Integer = rdr.GetInt32(8) 'Col5:IVeh
Dim LVeh As Integer = rdr.GetInt32(9) 'Col6:LVeh <-----
Dim v As Double = rdr.GetDouble(10) 'Col7:v <-----
Dim dv As Double = rdr.GetDouble(11) 'Col8:dv
Dim head As Double = rdr.GetDouble(12) 'Col9:head <-----
Dim length As Double = rdr.GetDouble(13) 'Col10:Length <-----
Dim type As Integer = rdr.GetInt32(14) 'Col11:Type <-----
Dim LCH As String = rdr.GetString(15) 'Col12:LCh
Dim a As Double = rdr.GetDouble(16) 'Col13:a <-----
Dim Route As Integer = rdr.GetInt32(17) 'Col14: Route #
Dim RouteD As Integer = rdr.GetInt32(18) 'Col15: Route Decision #

Dim zone As String = findZone(x)
Dim inOut As String = findInOut(Link)
Dim stage As String = findStage(Link, Time)

Dim DRACName As String = inOut & " " & stage & " " & zone
Dim DRACIndex As Integer = FindDRACIndex(DRACName)

''''''''Calculate DRAC for current row
Dim rowArray() As Object = {VehicleNum, Time, Link, x, Lane, IVeh, LVeh, v, dv, head, length, type, LCH, a, Route, RouteD,
DRACIndex}

currentTime = Time
If (rowTable.Count.Equals(0)) Then
    rowTable.Add(VehicleNum, rowArray)
ElseIf (currentTime <> lastTime) Then
    ' Calculate DRAC for rows in rowTable
    CalculateDRACForRowsInTable(StorageFolder, CurrentScenario, CurrentRun, rowTable)

    rowTable.Clear()
    rowTable.Add(VehicleNum, rowArray)
Else
    rowTable.Add(VehicleNum, rowArray)
End If

If (Not rdr.HasRows) Then
    ' Calculate DRAC for rows in rowTable
    CalculateDRACForRowsInTable(StorageFolder, CurrentScenario, CurrentRun, rowTable)
End If
lastTime = currentTime
''''''''''''''''''''

'''''' Calculate Entry/Exit Time
Dim TimeArray() As Double
Dim VehicleNumTable As Hashtable
If (Not VehicleEntryExitTable.ContainsKey(DRACIndex)) Then
    VehicleEntryExitTable.Add(DRACIndex, New Hashtable())
End If
VehicleNumTable = VehicleEntryExitTable(DRACIndex)

If (Not VehicleNumTable.ContainsKey(VehicleNum)) Then
    Dim tempArray(2) As Double
    tempArray(0) = Time 'StartTime
    tempArray(1) = Time 'EndTime
    VehicleNumTable.Add(VehicleNum, tempArray)
End If
TimeArray = VehicleNumTable(VehicleNum)
If (Time > TimeArray(1)) Then
    TimeArray(1) = Time
End If
''''''''''''''''''''

cnt = cnt + 1
End While

```

```

        rdr.Close()

Catch ex As Exception
    Console.Error.WriteLine(ex.StackTrace)
Throw ex
Finally
    conn.Close()
End Try

'''''''''' Write Vehicle Entry/Exit time to files
WriteEntryExitTime(StorageFolder, CurrentScenario, CurrentRun, VehicleEntryExitTable)

End Sub

Private Function findZone(ByVal x As Double) As String
    If (x >= 60.0) Then
        Return "Z2"
    Else
        Return "Z1"
    End If
End Function

Private Function findInOut(ByVal Link As Integer) As String
    If (Link.Equals(9)) Then
        Return "In"
    Else
        Return "Out"
    End If
End Function

Private Function findStage(ByVal Link As Integer, ByVal Time As Double) As String
    Dim stage As String = Nothing
    If Link.Equals(9) Then
        If Time <= TimeIn(1) Then
            stage = "1"
        ElseIf Time < TimeIn(2) Then
            stage = "2"
        ElseIf Time < TimeIn(3) Then
            stage = "3"
        ElseIf Time < TimeIn(4) Then
            stage = "4"
        Else
            stage = "5"
        End If
    ElseIf Link.Equals(19) Then

        If Time < TimeOut(1) Then
            stage = "1"
        ElseIf Time < TimeOut(2) Then
            stage = "2"
        ElseIf Time < TimeOut(3) Then
            stage = "3"
        ElseIf Time < TimeOut(4) Then
            stage = "4"
        Else
            stage = "5"
        End If
    End If
    Return stage
End Function

Private Sub GenerateDRACFiles(ByVal StorageFolder As String, ByVal CurrentScenario As Integer, ByVal CurrentRun As Integer)
    'Create Directory to stored DRAC files
    My.Computer.FileSystem.CreateDirectory(StorageFolder)

    'Create individual DRAC files
    Dim DRAClink As String
    Dim DRACFile As StreamWriter

```



```

For Each dracf In DRACFileS
    DRAClink = StorageFolder & "DRAC" & CurrentScenario & " " & CurrentRun & "_" & Array.IndexOf(DRACFileS, dracf) & ".text"
    DRACFile = My.Computer.FileSystem.OpenTextFileWriter(DRAClink, True)

DRACFile.WriteLine("Unsafty;TTC;DRAC;TimeLead;LeadNum;LeadType;LeadV;LeadA;TimeFol;FolNum;FolType;FolV;FolA;FolH;LeadLink;LeadX")
    DRACFile.Close()

    ' h = h + 1
Next
End Sub

Private Function FindDRACIndex(ByVal DRACName As String) As Integer
    Return Array.IndexOf(DRACFileS, DRACName)
End Function

Private Sub CalculateDRACForRowsInTable(ByVal StorageFolder As String, ByVal currentScenario As Integer, ByVal currentRun As Integer, ByRef rowTable As Hashtable)
    "Calculate DRAC for all rows in hashtable

For Each vehicleNum As Integer In rowTable.Keys
    Dim row() As Object = rowTable(vehicleNum)
    Dim LVeh As Integer = CInt(row(6)) 'Col6:LVeh <-----

'find if there is lead veh
If rowTable.ContainsKey(LVeh) Then
    Dim v As Double = CDbI(row(7)) 'Col7:v <-----
    ' Get lead vehicle row from hashtable
    Dim leadVRow() As Object = rowTable(LVeh)
    Dim Leadv As Double = CDbI(leadVRow(7)) 'Col7:v <-----

If (Leadv < v) Then
    Dim Time As Double = CDbI(row(1)) 'Col1: t <-----
    Dim Link As Integer = CInt(row(2)) 'Col2: Link
    Dim x As Double = CDbI(row(3)) 'Col3:x
    Dim Lane As Integer = CInt(row(4)) 'Col4:lane
    Dim IVeh As Integer = CInt(row(5)) 'Col5:IVeh
    Dim dv As Double = CDbI(row(8)) 'Col8:dv
    Dim head As Double = CDbI(row(9)) 'Col9:head <-----
    Dim length As Double = CDbI(row(10)) 'Col10:Length <-----
    Dim type As Integer = CInt(row(11)) 'Col11:Type <-----
    Dim LCH As String = CStr(row(12)) 'Col12:LCh
    Dim a As Double = CDbI(row(13)) 'Col13:a <-----
    Dim Route As Integer = CInt(row(14)) 'Col14: Route #
    Dim RouteD As Integer = CInt(row(15)) 'Col15: Route Decision #
    Dim FollowDRACIndex = CInt(row(16)) 'Col16: DRAC Index

    Dim LeadVehicleNum As Integer = CInt(leadVRow(0)) 'Col0: VehNr <-----
    Dim LeadTime As Double = CDbI(leadVRow(1)) 'Col1: t <-----
    Dim LeadLink As Integer = CInt(leadVRow(2)) 'Col2: Link
    Dim Leadx As Double = CDbI(leadVRow(3)) 'Col3:x
    Dim LeadLane As Integer = CInt(leadVRow(4)) 'Col4:lane
    Dim LeadIVeh As Integer = CInt(leadVRow(5)) 'Col5:IVeh
    Dim LeadLVeh As Integer = CInt(leadVRow(6)) 'Col6:LVeh <-----
    Dim Leaddv As Double = CDbI(leadVRow(8)) 'Col8:dv
    Dim Leadhead As Double = CDbI(leadVRow(9)) 'Col9:head <-----
    Dim Leadlength As Double = CDbI(leadVRow(10)) 'Col10:Length <-----
    Dim Leadtype As Integer = CInt(leadVRow(11)) 'Col11:Type <-----
    Dim LeadLCH As String = CStr(leadVRow(12)) 'Col12:LCh
    Dim Leada As Double = CDbI(leadVRow(13)) 'Col13:a <-----
    Dim LeadRoute As Integer = CInt(leadVRow(14)) 'Col14: Route #
    Dim LeadRouteD As Integer = CInt(leadVRow(15)) 'Col15: Route Decision #

'cal DRAC, TentryTC, UnSafety
Dim DRAC As Double
Dim TTC As Double
Dim UnSafety As Double
Dim RealHeadway As Single

```

```

RealHeadway = head - Leadlength
DRAC = (v - Leadv) ^ 2 / (2 * (RealHeadway))
TTC = RealHeadway / (v - Leadv)
If Leada < 0 Then
    If Leadtype = 100 Then
        UnSafety = (v - Leadv) * v * (Leada / 11.25)
    Else
        UnSafety = (v - Leadv) * v * (Leada / 7.81)
    End If
Else
    UnSafety = 0
End If
';TimeLead;LeadNum;LeadType;LeadV,LeadA;TimeFol;FolNum;FolType;FolV;FolA;FolH
writeDRACtoFile(StorageFolder, currentScenario, currentRun, FollowDRACIndex, DRAC, TTC, UnSafety,
    LeadTime, LeadVehicleNum, Leadtype, Leadv, Leada,
    Time, vehicleNum, type, v, a, head, LeadLink, Leadx)
Else
    'do nth
End If
End If

Next

End Sub

Private Sub writeDRACtoFile(ByVal StorageFolder As String, ByVal currentScenario As Integer, ByVal currentRun As Integer, ByVal
FollowDRACIndex As Integer, ByVal DRAC As Double, ByVal TTC As Double, ByVal UnSafety As Double, ByVal LeadTime As Double,
ByVal LeadVehicleNum As Integer, ByVal Leadtype As Integer, ByVal Leadv As Double, ByVal Leada As Double, ByVal Time As Double,
ByVal VehicleNum As Integer, ByVal type As Integer, ByVal v As Double, ByVal a As Double, ByVal head As Double, ByVal leadlink As
Double, ByVal leadx As Double)
    Dim DRACLine As String = CStr(Math.Round(UnSafety, 5)) & ";" & CStr(Math.Round(TTC, 5)) & ";" & CStr(Math.Round(DRAC, 5)) &
    ";" & CStr(LeadTime) & ";" & CStr(LeadVehicleNum) & ";" & CStr(Leadtype) & ";" & CStr(Leadv) & ";" & CStr(Leada) & ";" & CStr(Time)
    & ";" & CStr(VehicleNum) & ";" & CStr(type) & ";" & CStr(v) & ";" & CStr(a) & ";" & CStr(head) & ";" & CStr(leadlink) & ";" & CStr(leadx)
    Dim DRAClink As String = StorageFolder & "DRAC" & currentScenario & "_" & currentRun & "_" & FollowDRACIndex & ".text"
    Dim DRACFile As StreamWriter = My.Computer.FileSystem.OpenTextFileWriter(DRAClink, True)
    DRACFile.WriteLine(DRACLine)
    DRACFile.Close()
End Sub

Private Sub WriteEntryExitTime(ByVal StorageFolder As String, ByVal CurrentScenario As Integer, ByVal CurrentRun As Integer, ByVal
VehicleEntryExitTable As Hashtable)
    For j = 1 To DRACFileS.Length - 1 'j= 0 refers N/A????
        Dim CPIInput As String = StorageFolder & "CPIInput" & CurrentScenario & "_" & CurrentRun & "_" & j & ".text"
        Dim CPIInputFile As StreamWriter
        CPIInputFile = My.Computer.FileSystem.OpenTextFileWriter(CPIInput, True)
        CPIInputFile.WriteLine("Veh #; Entry Time; Exit Time")

        Dim vehicleTable As Hashtable = VehicleEntryExitTable(j)
        If (Not vehicleTable Is Nothing) Then
            For Each vehicleNum As Integer In vehicleTable.Keys
                Dim timeArray() As Double = vehicleTable(vehicleNum)
                Dim startTime As Double = timeArray(0)
                Dim endTime As Double = timeArray(1)
                CPIInputFile.WriteLine(vehicleNum & ";" & startTime & ";" & endTime)
            Next
        End If
        CPIInputFile.Close()
    Next
End Sub
End Module

```

## Sample Output of SP Output

Partial DRAC1\_1\_1.text

Unsafty;TTC;DRAC;TimeLead;LeadNum;LeadType;LeadV;LeadA;TimeFol;FolNum;FolType;FolV;FolA;FolH;LeadLink;LeadX  
-1.56025;4.2735;0.27378;87.9;15;100;7.53;-0.76;87.9;16;100;9.87;-0.62;14.8;19;75.3  
-1.4065;4.1453;0.28225;88.15;100;7.46;-0.69;88.16;100;9.8;-0.66;14.5;19;76  
-1.24942;4.07725;0.28573;88.1;15;100;7.4;-0.62;88.1;16;100;9.73;-0.69;14.3;19;76.8  
-1.11558;3.96552;0.29252;88.2;15;100;7.34;-0.56;88.2;16;100;9.66;-0.72;14;19;77.5  
-0.98031;3.91304;0.29389;88.3;15;100;7.29;-0.5;88.3;16;100;9.59;-0.75;13.8;19;78.2  
-0.86351;3.87665;0.29278;88.4;15;100;7.24;-0.45;88.4;16;100;9.51;-0.78;13.6;19;78.9  
-0.76639;3.8565;0.28912;88.5;15;100;7.2;-0.41;88.5;16;100;9.43;-0.81;13.4;19;79.7  
-0.66659;3.82488;0.28367;88.6;15;100;7.17;-0.37;88.6;16;100;9.34;-0.83;13.1;19;80.4  
-0.57856;3.80282;0.28006;88.7;15;100;7.13;-0.33;88.7;16;100;9.26;-0.86;12.9;19;81.1  
-0.50618;3.81643;0.2712;88.8;15;100;7.1;-0.3;88.8;16;100;9.17;-0.88;12.7;19;81.8  
0;3.90863;0.25201;88.9;15;100;7.11;0.07;88.9;16;100;9.08;-0.9;12.5;19;82.5  
-1.52522;7.23881;0.09256;140.9;21;100;8.51;-1.3;140.9;22;100;9.85;-0.26;13.8;19;74.3  
-1.43854;6.80851;0.10355;141.2;21;100;8.4;-1.17;141.2;22;100;9.81;-0.32;13.7;19;75.1  
-1.36007;6.37584;0.11685;141.1;21;100;8.29;-1.05;141.1;22;100;9.78;-0.38;13.6;19;75.9  
-1.25712;6.07843;0.12585;141.2;21;100;8.2;-0.95;141.2;22;100;9.73;-0.44;13.4;19;76.8  
-1.16529;5.78616;0.1374;141.3;21;100;8.11;-0.85;141.3;22;100;9.7;-0.35;13.3;19;77.6  
-1.07771;5.52147;0.14761;141.4;21;100;8.03;-0.77;141.4;22;100;9.66;-0.38;13.1;19;78.4  
-0.97944;5.3012;0.15657;141.5;21;100;7.96;-0.69;141.5;22;100;9.62;-0.42;12.9;19;79.2  
-0.88078;5.20958;0.16028;141.6;21;100;7.9;-0.62;141.6;22;100;9.57;-0.45;12.8;19;80  
-0.79139;5.08982;0.16405;141.7;21;100;7.85;-0.56;141.7;22;100;9.52;-0.48;12.6;19;80.8  
-0.70288;4.97006;0.16801;141.8;21;100;7.8;-0.5;141.8;22;100;9.47;-0.51;12.4;19;81.6  
-0.62926;4.91018;0.17005;141.9;21;100;7.75;-0.45;141.9;22;100;9.42;-0.53;12.3;19;82.3  
-4.01008;4.80132;0.3145;181.4;27;100;14.35;-0.86;181.4;28;100;17.37;-1.15;19;78.7  
-3.53224;4.74916;0.31479;181.5;27;100;14.27;-0.77;181.5;28;100;17.26;-1.15;18.7;19;80.1  
-3.13548;4.72789;0.31092;181.6;27;100;14.2;-0.7;181.6;28;100;17.14;-1.15;18.4;19;81.5  
-2.7673;4.68966;0.30919;181.7;27;100;14.14;-0.63;181.7;28;100;17.04;-1.06;18.1;19;82.9  
-2.08128;5.4;0.13889;224.9;35;100;9.34;-1.44;224.9;36;100;10.84;-1.08;12.2;19;72.3  
-1.87017;5.26316;0.1444;225.35;100;9.21;-1.29;225.36;100;10.73;-1.13;12.1;19;73.2  
-1.66289;5.13158;0.1481;225.1;35;100;9.09;-1.16;225.1;36;100;10.61;-1.16;11.9;19;74.1  
-1.4798;5.09934;0.14806;225.2;35;100;8.99;-1.05;225.2;36;100;10.5;-1.16;11.8;19;75  
-1.29229;5.03356;0.14801;225.3;35;100;8.89;-0.94;225.3;36;100;10.38;-1.14;11.6;19;75.9

**CPI Entry Exit Time File (CPI1\_1\_1.text)**

Veh #; Entry Time; Exit Time

32;208.4;211

47;349.6;354.1

23;152.8;155

57;425.8;427.9

90;719.1;721.4

70;547.2;551.7

13;67.3;70.3

**Sample Output from VB code (Percentile)**

Vol	Bus	Lane	Zone	Scenario#	CurrentRun	DRAC85
500	0	0.1	Z1	1	1	0.17
500	0	0.1	Z1	1	2	0.14
500	0	0.1	Z1	1	3	0.17
500	0	0.1	Z1	1	4	0.18
500	0	0.1	Z1	1	5	0.17
500	0	0.1	Z1	1	6	0.17
500	0	0.1	Z1	1	7	0.15
500	0	0.1	Z1	1	8	0.13
500	0	0.1	Z1	1	9	0.21
500	0	0.1	Z1	1	10	0.15
500	0	0.1	Z1	1	11	0.14
500	0	0.1	Z1	1	12	0.15
500	0	0.1	Z1	1	13	0.16
500	0	0.1	Z1	1	14	0.17
500	0	0.1	Z1	1	15	0.17
500	0	0.1	Z1	1	16	0.17
500	0	0.1	Z1	1	17	0.16
500	0	0.1	Z1	1	18	0.17
500	0	0.1	Z1	1	19	0.16
500	0	0.1	Z1	1	20	0.14
500	0	0.1	Z1	1	21	0.15
500	0	0.1	Z1	1	22	0.15
500	0	0.1	Z1	1	23	0.17
500	0	0.1	Z1	1	24	0.16
500	0	0.1	Z1	1	25	0.16
500	0	0.1	Z1	1	26	0.16
500	0	0.1	Z1	1	27	0.14
500	0	0.1	Z1	1	28	0.16
500	0	0.1	Z1	1	29	0.15
500	0	0.1	Z1	1	30	0.18
500	0	0.5	Z1	2	1	0.20
500	0	0.5	Z1	2	2	0.18
500	0	0.5	Z1	2	3	0.21

## Calculate CPI and Summarize Data in Percentile Format

Imports FoundaStat  
Imports System.IO

Module Percentile

```
Dim CurrentScenario As Integer
Dim StartScen As Integer
Dim TotScen As Integer
Dim CurrentRun As Integer
Dim StartRun As Integer
Dim TotRun As Integer
Dim CurrentPhase As Integer
Dim StartPhase As Integer
Dim TotPhase As Integer
Dim Vol As Integer
Dim Bus As Single
Dim lane As Single
Dim EXLine As String
Dim DRACLine As String
Dim Directory As String = "D:\VISSIM_January\Test9Link\"
Dim Zone As String
Dim Link As Integer
Dim Coor As Single
Sub main()
    Dim foundaStatMain As New FoundaStatProMainDll
    Dim blDimensionedZ1 As Boolean
    Dim blDimensionedZ2 As Boolean
```

```
TotScen = 27
TotRun = 30
TotPhase = 20
StartScen = 1
StartRun = 1
StartPhase = 1
'Hashtable to store CPI values for each Scenario# and Run# combo
Dim Ptitle As String = "Vol;Bus;Lane;Zone;Scenario#;CurrentRun;"
Dim title As String
title = "Vol;Bus;Lane;Run#;Scenario#;CurrentRun;Link;X"
writeToFile(title, "Location.txt")
title = Ptitle & "SP;CriticalValue"
writeToFile(title, "Critical.txt")
title = Ptitle & "DRAC85Z1"
writeToFile(title, "DRAC85Z1.txt")
title = Ptitle & "CPI85Z1"
writeToFile(title, "CPI85Z1.txt")
title = Ptitle & "UD85Z1"
writeToFile(title, "UD85Z1.txt")
title = Ptitle & "TTC15"
writeToFile(title, "TTC15Z1.txt")
title = Ptitle & "DRAC85Z2"
writeToFile(title, "DRAC85Z2.txt")
title = Ptitle & "CPI85Z2"
writeToFile(title, "CPI85Z2.txt")
title = Ptitle & "UD85Z2"
writeToFile(title, "UD85Z2.txt")
title = Ptitle & "TTC15"
writeToFile(title, "TTC15Z2.txt")
```

```
For CurrentScenario = StartScen To TotScen
    Console.WriteLine("Start Scenario" & CurrentScenario & " at " & Now())
    CheckScen()
    For CurrentRun = StartRun To TotRun
        Console.WriteLine("Start Scenario" & CurrentScenario & "; Start Run" & CurrentRun & " at " & Now())
        Dim cpiTableZ1 As Hashtable = New Hashtable()
```

```

Dim vehicleTimeTableZ1 As Hashtable = New Hashtable()
Dim cpiTableZ2 As Hashtable = New Hashtable()
Dim vehicleTimeTableZ2 As Hashtable = New Hashtable()
Dim MaxDRAC As Double = 0
Dim DRACAZ1(0 To 0) As Double
Dim TTCAZ1(0 To 0) As Double
Dim safetyAZ1(0 To 0) As Double
Dim DRACAZ2(0 To 0) As Double
Dim TTCAZ2(0 To 0) As Double
Dim safetyAZ2(0 To 0) As Double
blDimensionedZ1 = False
blDimensionedZ2 = False
'FIRST READING, LOAD IN DATA TO GET descriptive stat
For CurrentPhase = StartPhase To TotPhase
    Console.WriteLine("FirstLoad Scenario" & CurrentScenario & "; Start Run" & CurrentRun & "Start Phase" & CurrentPhase &
" at " & Now())
    'open EX file
    Dim DRACFile As StreamReader = New StreamReader(Directory & "S" & CurrentScenario & "_Test9\DRAC" &
CurrentScenario & "_" & CurrentRun & "_" & CurrentPhase & ".text")
    DRACFile.ReadLine()

    Do
        DRACLine = DRACFile.ReadLine()
        If (DRACLine = Nothing) Then
            Exit Do
        End If
        'Unsafety;TTC;DRAC;TimeLead;LeadNum;LeadType;LeadV;LeadA;TimeFol;FolNum;FolType;FolV;FolA;FolH
        Dim token() As String = DRACLine.Split(CChar(";"))
        Dim Unsafety As Double = CDbI(token(0))
        Dim TTC As Double = CDbI(token(1))
        Dim DRAC As Double = CDbI(token(2))
        Dim fNum As Integer = CInt(token(9))

        If CurrentPhase Mod 2 = 0 Then
            Zone = "Z2"
            If blDimensionedZ2 = False Then
                safetyAZ2(0) = Unsafety
                TTCAZ2(0) = TTC
                DRACAZ2(0) = DRAC
                blDimensionedZ2 = True
            Else
                ReDim Preserve safetyAZ2(0 To (UBound(safetyAZ2) + 1))
                safetyAZ2(UBound(safetyAZ2)) = Unsafety

                ReDim Preserve TTCAZ2(0 To (UBound(TTCAZ2) + 1))
                TTCAZ2(UBound(TTCAZ2)) = TTC

                ReDim Preserve DRACAZ2(0 To (UBound(DRACAZ2) + 1))
                DRACAZ2(UBound(DRACAZ2)) = DRAC
            End If
        Else
            Zone = "Z1"
            If blDimensionedZ1 = False Then
                safetyAZ1(0) = Unsafety
                TTCAZ1(0) = TTC
                DRACAZ1(0) = DRAC
                blDimensionedZ1 = True
            Else
                ReDim Preserve safetyAZ1(0 To (UBound(safetyAZ1) + 1))
                safetyAZ1(UBound(safetyAZ1)) = Unsafety

                ReDim Preserve TTCAZ1(0 To (UBound(TTCAZ1) + 1))
                TTCAZ1(UBound(TTCAZ1)) = TTC

                ReDim Preserve DRACAZ1(0 To (UBound(DRACAZ1) + 1))

```

```

        DRACAZ1(UBound(DRACAZ1)) = DRAC
    End If
End If

Loop Until DRACFile Is Nothing
DRACFile.Close()
Next

'get the percentile
Dim TTCdespZ1 As New Descriptive(TTCAZ1)
TTCdespZ1.Analyze()
Dim DRACdespZ1 As New Descriptive(DRACAZ1)
DRACdespZ1.Analyze()
Dim UDdespZ1 As New Descriptive(safetyAZ1)
UDdespZ1.Analyze()
Dim TTCdespZ2 As New Descriptive(TTCAZ2)
TTCdespZ2.Analyze()
Dim DRACdespZ2 As New Descriptive(DRACAZ2)
DRACdespZ2.Analyze()
Dim UDdespZ2 As New Descriptive(safetyAZ2)
UDdespZ2.Analyze()

Dim TTC15PZ1 As Double = TTCdespZ1.Result.Percentile(0.15)
Dim DRAC85PZ1 As Double = DRACdespZ1.Result.Percentile(0.85)
Dim UD85PZ1 As Double = UDdespZ1.Result.Percentile(0.85)
Dim TTC15PZ2 As Double = TTCdespZ2.Result.Percentile(0.15)
Dim DRAC85PZ2 As Double = DRACdespZ2.Result.Percentile(0.85)
Dim UD85PZ2 As Double = UDdespZ2.Result.Percentile(0.85)

Dim TTC15PZ1_Median As Double = TTCdespZ1.Result.median
Dim DRAC85PZ1_Median As Double = DRACdespZ1.Result.median
Dim UD85PZ1_Median As Double = UDdespZ1.Result.median
Dim TTC15PZ2_Median As Double = TTCdespZ2.Result.median
Dim DRAC85PZ2_Median As Double = DRACdespZ2.Result.median
Dim UD85PZ2_Median As Double = UDdespZ2.Result.median

Dim TTC15PZ1_min As Double = TTCdespZ1.Result.min
Dim DRAC85PZ1_max As Double = DRACdespZ1.Result.max
Dim UD85PZ1_max As Double = UDdespZ1.Result.max
Dim TTC15PZ2_min As Double = TTCdespZ2.Result.min
Dim DRAC85PZ2_max As Double = DRACdespZ2.Result.max
Dim UD85PZ2_max As Double = UDdespZ2.Result.max

Dim line As String
line = Vol & ";" & Bus & ";" & lane & ";Z1;" & CurrentScenario & ";" & CurrentRun & ";TTCZ1;" & TTC15PZ1 & ";" &
TTC15PZ1_Median & ";" & TTC15PZ1_min
writeToFile(line, "Critical.txt")
line = Vol & ";" & Bus & ";" & lane & ";Z2;" & CurrentScenario & ";" & CurrentRun & ";TTCZ2;" & TTC15PZ2 & ";" &
TTC15PZ2_Median & ";" & TTC15PZ2_min
writeToFile(line, "Critical.txt")
line = Vol & ";" & Bus & ";" & lane & ";Z1;" & CurrentScenario & ";" & CurrentRun & ";DRACZ1;" & DRAC85PZ1 & ";" &
DRAC85PZ1_Median & ";" & DRAC85PZ1_max
writeToFile(line, "Critical.txt")
line = Vol & ";" & Bus & ";" & lane & ";Z2;" & CurrentScenario & ";" & CurrentRun & ";DRACZ2;" & DRAC85PZ2 & ";" &
DRAC85PZ2_Median & ";" & DRAC85PZ2_max
writeToFile(line, "Critical.txt")
line = Vol & ";" & Bus & ";" & lane & ";Z1;" & CurrentScenario & ";" & CurrentRun & ";UDZ1;" & UD85PZ1 & ";" &
UD85PZ1_Median & ";" & UD85PZ1_max
writeToFile(line, "Critical.txt")
line = Vol & ";" & Bus & ";" & lane & ";Z2;" & CurrentScenario & ";" & CurrentRun & ";UDZ2;" & UD85PZ2 & ";" &
UD85PZ2_Median & ";" & UD85PZ2_max
writeToFile(line, "Critical.txt")

'prepare for next stage (store filtered data)
Dim DRACHZ1 As New Hashtable
Dim TTCHZ1 As New Hashtable

```



```

Dim UDHZ1 As New Hashtable
Dim DRACcountHZ1 As New Hashtable
Dim TTCCountHZ1 As New Hashtable
Dim UDCountHZ1 As New Hashtable
Dim DRACHZ2 As New Hashtable
Dim TTCHZ2 As New Hashtable
Dim UDHZ2 As New Hashtable
Dim DRACcountHZ2 As New Hashtable
Dim TTCCountHZ2 As New Hashtable
Dim UDCountHZ2 As New Hashtable
'read file again to filter and sum the sp to get the avg for each veh later on
For CurrentPhase = StartPhase To TotPhase
    Console.WriteLine("2nd Load Scenario" & CurrentScenario & "; Start Run" & CurrentRun & "Start Phase" & CurrentPhase &
" at " & Now())
    'open EX file
    Dim DRACFile As StreamReader = New StreamReader(Directory & "S" & CurrentScenario & "_Test9\DRAC" &
CurrentScenario & "_" & CurrentRun & "_" & CurrentPhase & ".text")
    DRACFile.ReadLine()

    Do
        DRACLine = DRACFile.ReadLine()
        If (DRACLine = Nothing) Then
            Exit Do
        End If
        'Unsafety;TTC;DRAC;TimeLead;LeadNum;LeadType;LeadV;LeadA;TimeFol;FolNum;FolType;FolV;FolA;FolH
        Dim token() As String = DRACLine.Split(CChar(";"))

        Dim Unsafety As Double = Cdbl(token(0))
        Dim TTC As Double = Cdbl(token(1))
        Dim DRAC As Double = Cdbl(token(2))
        Dim fNum As Integer = CInt(token(9))
        Link = CInt(token(14))
        Coor = CSng(token(15))
        'add lane,bus,vol

        If CurrentPhase Mod 2 = 0 Then
            Zone = "Z2"
            If TTC < TTC15PZ2 Then
                StoreFilteredData(TTCHZ2, TTCCountHZ2, fNum, TTC)
            End If

            If DRAC > DRAC85PZ2 Then
                StoreFilteredData(DRACHZ2, DRACcountHZ2, fNum, DRAC)
                'cal partial prob.
                Dim fType As Integer = CInt(token(10))

                calPartialCPI(fType, cpiTableZ2, DRAC, fNum)
            End If

            If Unsafety > UD85PZ2 Then
                StoreFilteredData(UDHZ2, UDCountHZ2, fNum, Unsafety)
            End If
        Else
            Zone = "Z1"
            If TTC < TTC15PZ1 Then
                StoreFilteredData(TTCHZ1, TTCCountHZ1, fNum, TTC)
            End If

            If DRAC > DRAC85PZ1 Then
                StoreFilteredData(DRACHZ1, DRACcountHZ1, fNum, DRAC)
                'cal partial prob.
                Dim fType As Integer = CInt(token(10))
                calPartialCPI(fType, cpiTableZ1, DRAC, fNum)
            End If
        End If
    Loop
End For

```

```

    If Unsafety > UD85PZ1 Then
        StoreFilteredData(UDHZ1, UDCCountHZ1, fNum, Unsafety)
    End If
End If

.....

Loop Until DRACFile Is Nothing
DRACFile.Close()

StoreEX(vehicleTimeTableZ1)
StoreEX(vehicleTimeTableZ2)

Next

CalFinalSP(DRACHZ1, DRACcountHZ1, "DRAC85Z1.txt", "Z1")
CalFinalSP(TTCHZ1, TTCCountHZ1, "TTC15Z1.txt", "Z2")
CalFinalSP(UDHZ1, UDCCountHZ1, "UD85Z1.txt", "Z1")
CalFinalSP(DRACHZ2, DRACcountHZ2, "DRAC85Z2.txt", "Z2")
CalFinalSP(TTCHZ2, TTCCountHZ2, "TTC15Z2.txt", "Z1")
CalFinalSP(UDHZ2, UDCCountHZ2, "UD85Z2.txt", "Z2")
'End of all phases...now calculate CPI
' Loop through CPI table for each vehicle found in vehicleTime table...divide to calculate real CPI

Dim SumCPI As Double = 0
Dim CountCPI As Integer = 0
For Each vehicleNum As Integer In cpiTableZ1.Keys
    If (vehicleTimeTableZ1.ContainsKey(vehicleNum)) Then
        Dim vehicleCPI As Double = Cdbl(cpiTableZ1.Item(vehicleNum))
        Dim vehicleTotalTime As Double = Cdbl(vehicleTimeTableZ1.Item(vehicleNum))
        Dim realCPI As Double = vehicleCPI / vehicleTotalTime
        SumCPI = SumCPI + realCPI
        CountCPI = CountCPI + 1
    End If
Next

Dim finalepi As Double
finalepi = SumCPI / CountCPI
line = Vol & ";" & Bus & ";" & lane & ";Z1;" & CurrentScenario & ";" & CurrentRun & ";" & finalepi
writeToFile(line, "CPI85Z1.txt")

SumCPI = 0
CountCPI = 0
For Each vehicleNum As Integer In cpiTableZ2.Keys
    If (vehicleTimeTableZ2.ContainsKey(vehicleNum)) Then
        Dim vehicleCPI As Double = Cdbl(cpiTableZ2.Item(vehicleNum))
        Dim vehicleTotalTime As Double = Cdbl(vehicleTimeTableZ2.Item(vehicleNum))
        Dim realCPI As Double = vehicleCPI / vehicleTotalTime
        SumCPI = SumCPI + realCPI
        CountCPI = CountCPI + 1
    End If
Next
finalepi = SumCPI / CountCPI
line = Vol & ";" & Bus & ";" & lane & ";Z2;" & CurrentScenario & ";" & CurrentRun & ";" & finalepi
writeToFile(line, "CPI85Z2.txt")

Next
Next
Console.WriteLine("Finish....press Enter to continue.")
Console.In.ReadLine()

```

```

End Sub

Private Sub writeToFile(ByVal line As String, ByVal filename As String)
    Dim CPIFile As StreamWriter = My.Computer.FileSystem.OpenTextFileWriter(Directory & filename, True)
    CPIFile.WriteLine(line)
    CPIFile.Close()
End Sub

Sub CalFinalSP(ByRef ValueH As Hashtable, ByRef Counth As Hashtable, ByVal filename As String, ByVal ZONE2 As String)
    Dim tmpcount As Integer = 0
    Dim tmpV As Double = 0
    Dim tmpSum As Double = 0
    Dim finalSP As Double = 0
    For Each Vnum As Integer In ValueH.Keys
        tmpV = CDBl(ValueH.Item(Vnum))
        tmpcount = CInt(Counth.Item(Vnum))

        tmpSum = tmpSum + tmpV / tmpcount

    Next
    finalSP = tmpSum / ValueH.Count

    Dim tmpLine As String = Vol & ";" & Bus & ";" & lane & ";" & ZONE2 & ";" & CurrentScenario & ";" & CurrentRun & ";" & finalSP
    writeToFile(tmpLine, filename)
End Sub

Sub StoreFilteredData(ByRef ValH As Hashtable, ByRef CountH As Hashtable, ByVal fnum As Integer, ByVal SPV As Double)
    If (Not ValH.ContainsKey(fnum)) Then
        ValH.Add(fnum, SPV)
        CountH.Add(fnum, 1)
    Else
        Dim existingTTC As Double = CDBl(ValH.Item(fnum))
        Dim newTTC As Double = existingTTC + SPV
        ValH.Remove(fnum)
        ValH.Add(fnum, newTTC)
        Dim tmpCount As Integer = CInt(CountH.Item(fnum))
        CountH.Item(fnum) = tmpCount + 1
    End If
End Sub

Sub calPartialCPI(ByVal ftype As Integer, ByRef Vtable As Hashtable, ByVal DRAC As Double, ByVal fnum As Integer)
    'cal partial prob.
    Dim mean As Double
    Dim sd As Double

    If (ftype.Equals(100)) Then
        mean = 8.45
        sd = 1.4
    ElseIf (ftype.Equals(200)) Then
        mean = 5.01
        sd = 1.4
    Else
        mean = 5.01
        sd = 1.4
    End If

    If DRAC > mean Then
        Dim tmpLine As String
        tmpLine = Vol & ";" & Bus & ";" & lane & ";" & fnum & ";" & CurrentScenario & ";" & CurrentRun & ";" & Link & ";" & Coord
        writeToFile(tmpLine, "Location.txt")
    End If

    Dim partialCPI As Double = (NormalDistribution.cdf(DRAC, mean, sd)) * 0.1

    If (Not Vtable.ContainsKey(fnum)) Then
        Vtable.Add(fnum, partialCPI)
    Else
        Dim existingCPI As Double = CDBl(Vtable.Item(fnum))

```

```

        Dim newCPI As Double = existingCPI + partialCPI
        Vtable.Remove(fnum)
        Vtable.Add(fnum, newCPI)
    End If

End Sub
Sub StoreEX(ByRef vehicletimetable As Hashtable)
    'open EX file
    Dim EXFile As StreamReader = New StreamReader(Directory & "S" & CurrentScenario & "_Test9\CPIInput" & CurrentScenario &
    "_" & CurrentRun & "_" & CurrentPhase & ".text")
    EXFile.ReadLine()

    Do
        EXLine = EXFile.ReadLine()
        If (EXLine = Nothing) Then
            Exit Do
        End If
        'Veh #; Entry Time; Exit Time
        Dim token2() As String = EXLine.Split(CChar(";"))
        Dim vNum As Integer = CInt(token2(0))
        Dim startTime As Double = CDb1(token2(1))
        Dim endTime As Double = CDb1(token2(2))
        Dim diffTime As Double = endTime - startTime

        If (Not vehicletimetable.ContainsKey(vNum)) Then
            vehicletimetable.Add(vNum, diffTime)
        Else
            Dim existingDiffTime As Double = CDb1(vehicletimetable.Item(vNum))
            Dim newDiffTime As Double = existingDiffTime + diffTime
            vehicletimetable.Remove(vNum)
            vehicletimetable.Add(vNum, newDiffTime)
        End If
    Loop Until EXLine Is Nothing
    EXFile.Close()

End Sub
Sub CheckScen()
    If CurrentScenario >= 1 And CurrentScenario <= 9 Then
        Vol = 500
    ElseIf CurrentScenario > 9 And CurrentScenario <= 18 Then
        Vol = 1000
    Else
        Vol = 2000
    End If

    If CurrentScenario Mod 3 = 0 Then
        lane = 0.9
    ElseIf CurrentScenario Mod 3 = 2 Then
        lane = 0.5
    Else
        lane = 0.1
    End If

    If CurrentScenario Mod 9 = 1 Or CurrentScenario Mod 9 = 2 Or CurrentScenario Mod 9 = 3 Then
        Bus = 0
    ElseIf CurrentScenario Mod 9 = 4 Or CurrentScenario Mod 9 = 5 Or CurrentScenario Mod 9 = 6 Then
        Bus = 0.05
    Else
        Bus = 0.2
    End If
End Sub

End Module

```

## References

- Ammoun, S., & Nashashibi, F. (2009). Real Time Trajectory Prediction for Collision Risk Estimation Between Vehicle. *ICCP 2009*. France.
- Barcelo, J., Dumont, A. G., Montero, L., Perarnau, J., & Torday, A. (2003). Safety Indicators for Microsimulation-based Assessments. Transportation Research Board 2003 Annual Meeting.
- Blincoe, L., Seay, A., Zaloshnja, E., Miller, T., Romano, E., Luchter, S., et al. (2002). *The Economic Impact of Motor Vehicle Crashes, 2000*. U.S.: U.S. Department of Transportation.
- Caird, J., Creaser, J., Edwards, C., & Dewar, R. (2002). *A Human Factors Analysis of Highway-Railway Grade Crossing Accidents in Canada*. Canada: Transport Canada.
- Canada, T. S. (2008). *Rail Statistic*. Retrieved from <http://www.tsb.gc.ca/eng/stats/rail/prelim-2008/index.asp>
- Chu, X. (1994). *The Effects of Age on the Driving Habits of the Elderly*. Office of University Research and Education Resesarch and Special Program Administration. U.S.: U.S. Department of Transportation.
- Coleman, F. I., & Moon, Y. J. (1999). Driver Speed Reduction Behavior at Highway Rail Intersections. *Journal of Transportation Research Board* , 1692, 94-105.
- Coleman, F. I., & Moon, Y. (1997). System Simulation of Dual-Gate At-Grade Railroad-Highway Crossings Development and Verification. (1605), 88-95.
- Cooper, D. F., & Ferguson, N. (1976). Traffic studies at t-junctions - a conflict simulation model. *17*, 306-309.
- Courage, K., & Kirkpatrick, B. (2003). *Video Based Studies of Flexible Traffic Separators at Highway-Railroad Grade Crossings*. U.S.: Florida Department of Transpoortation.
- Cunto, F. (2008). *Assessing Safety Performance of Transportation Systems Using Microscopic Simulation*. Canada: University of Waterloo.
- Cunto, F., & Saccomanno, F. (2008). Calibration and Validation of Simulated Vehicle Safety Performance at Signalized Intersection. *Accident Analysis and Prevention* , 40 (3), pp. 1171-1179.
- Darzentas, J., & McDowell, M. (1981). Driver behavior at unlit non-urban T-junctions in daylight and darkness. *32*, 721-727.
- Federal Hgiway Administration. (2009). *Manual on Uniform Traffic Control Devices for Streets and Highway*. U.S.

Federal Highway Administration. (2004). *General*. Retrieved 04 08, 2010, from NGSIM Community: [http://ngsim-community.org/index.php?option=com\\_docman&task=doc\\_download&gid=9&Itemid=34](http://ngsim-community.org/index.php?option=com_docman&task=doc_download&gid=9&Itemid=34)

Gettman, D., & Head, L. (2003). *Surrogate Safety Measures From Traffic Simulation Models, Final Report*. United States: Federal Highway Administration.

Gipps, P. (1981). A behavior car following model for computer simulation. *15* (105-111), 105-111.

Google. (2010). Google Street View. Kitchener.

Hayward, J. C. (1972). Near-miss determination through use of a scale of dange. *384*, 24-34.

Horst, A. v. (1990). A Time-Based Analytsis of Road User Behavior in Normal and Critical Encounters. Delft: Delft University of Technology.

Hyden, C. (1987). The development of a method for traffic safety evaluation: The swedish traffic conflicts technique. *Bulletin 70. Department of Traffic Planning and Engineering* .

Hyden, C. (1996). *Traffic Safety Work with Video-processing*. University Kaiserslautern, Transportation Department.

L., P. A. (1953). An Operational analysis of traffic dynamics. *24* (3), 274-287.

Leibowitz, H. (1985). Grade crossing accidents and human factors engineering. *73*, 558-562.

Levinson, D. (2008). *Fundamental Diagram of Traffic Flow*. Retrieved 07 07, 2010, from <http://upload.wikimedia.org/wikipedia/commons/b/b8/TraditionalTrafficFlowModel.png>

Lyons, G., Hunt, J., & McLeod, F. (2001). A neural network model for enhanced operation of midblock signalled pedestrian crossings. *129*, 346-354.

Mathew, T. V., & Radhakrishnan, P. (2010). Calibration of Microsimulation Models for Nonlane-Based Heterogeneous Traffic at Signalized Intersections. *136* (1), 59-66.

Ministry of Ontario. (2010, 06 03). *Highway Traffic Act T.S.O. 1990*. Retrieved 06 08, 2010, from [http://www.e-laws.gov.on.ca/html/statutes/english/elaws\\_statutes\\_90h08\\_e.htm](http://www.e-laws.gov.on.ca/html/statutes/english/elaws_statutes_90h08_e.htm)

Newell, G. (1961). Nnlinear effects in the dynamics of car following. *9* (2), 209-229.

Ng, O. K., & Saccomanno, F. (2010). Speed Reduction Profiles Affecting Vehicle Interactions at Level Crossings in the Absence of Trains. *Journal of the Transportation Research Board* , *2149*, 108-114.

Office of Traffic Operations, Federal Highway Administration. (1985). *The 1985 Highway Capacity Manual*. U.S.

Pant, P. D. (1994). Neural Network for Gap Acceptance at Stop-Controlled Intersections. *120* (3), 432-446.

- PTV. (2008). VISSIM 5.1 Manual. Germany.
- Robert, A. C., & Esplain, J. B. (2005). *Congestion Mitigation at Railroad-Highway At-Grade Crossings*. U.S.: ARIZONA DEPARTMENT OF TRANSPORTATION .
- Rossi, R., & Meneguzzer, C. (2009). The effect of crisp variables on fuzzy models of gap-acceptance behavior. *Handling Uncertainty in the Analysis of Traffic and Transportation Systems*. Italy.
- Saccomanno, F. F., Cunto, F., Guido, G., & Vitale, A. (2008). Comparing Safety at Signalized Intersections and Roundabouts Using Simulated Rear-End Conflicts. *Journal of the Transportation Research Board* (2078), 90-95.
- Tenkink, E., & Van der Horst, R. (1990). Driver Behavior at Flashing Light Rail-road Grade Crossing. *Accident Analysis & Prevention* , 22 (3), 229-39.
- Transportation Safety Board of Canada. (2008). *Statistical Summary Railway Occurrences 2007*. Canada.
- Tydlacka, J. (2004). A Microsimulation Analysis of Highway at Intersections near Highway-Railroad Grade Crossings. U.S.: Texas A&M University.
- Ward, N., & Wilde, G. (1995). A Comparison of Vehicular Approach Speed and Braking between Day and Nighttime Periods at an Automated Railway Crossing. *19* (1), 31-44.
- Ward, N., & Wilde, G. (1996). Driver approach behavior at an unprotected railway crossing before and after enhancement of later sight distances: An experimental investigation of a risk perception and behavioral compensation hypothesis. *Safety Science* , 22 (1-3), 63-75.
- Yeh, M., & Multer, J. (2008). *Driver Behavior at Highway-Railroad Grade Crossings: A Literature Review from 1990-2006* . U.S.: U.S. Department of Transportation .
- Yu, L., Yu, L., Chen, X., Wan, T., & Guo, J. (2006). Calibration of VISSIM for Bus Rapid Transit Systems in Beijing Using GPS Data. *BRT Special Edition*.