

Too Much Information

by

Vien Nguyen

A thesis
presented to the University of Waterloo
in fulfilment of the
thesis requirement for the degree of
Master of Architecture

Waterloo, Ontario, Canada, 2012

© Vien Nguyen 2012

I hereby declare that I am the sole author of this thesis.
This is a true copy of the thesis, including any required
final revisions, as accepted by my examiners.

I understand that my thesis may be made electronically
available to the public.

ABSTRACT

This book begins with a mysterious illness in Florence and ends in the half-light of an American desert night. Notes are gathered, impressions taken, sketches made, and objects found, all leading to and from six buildings, represented in twelve objects. These pieces – mute miniatures of the void inside and outside these six buildings – organize this mix of voices, images, and ideas. In six parts we wander through a baptistery in Florence, an orangerie at the garden of Versailles, a long-gone tower in Coney Island, a palace bath at the Alhambra, the Tate Modern's Turbine Hall, and the Great Pyramid of Giza.

One way of looking at architecture in the midst of too much – too much to feel, too much to think, too much to know, too much to see – this is a record of how to make do with what is left.

ACKNOWLEDGEMENTS

A most heartfelt thank-you to my supervisor, Donald McKay, for his guidance, his wisdom, and his enthusiasm throughout the entire thesis. Many thanks to my committee members, Ryszard Sliwka and Robert Jan van Pelt, for their thoughtful questions and comments as the thesis came together. This book also owes much to E.Jae Hamilton's sharp eye and sympathetic ear: J.P., thanks, ever so.

And above all, thanks to my dear friends and family, for seeing me through this with their patience, care, and love.

For my parents, Truong and Muoi.

TABLE OF CONTENTS

<i>Author's Declaration</i>	ii
<i>Abstract</i>	iii
<i>Acknowledgements</i>	iv
<i>Dedication</i>	v
<i>List of Illustrations</i>	ix
1. DEAR READER	3
2. NOTEBOOKS	9
3. MAKING STUFF	57
4. SIX PARTS	67
The Door	69
The Stage	89
The Pylon	109
The Frame	129
The Room	149
The Passage	169
5. OBJECTS	189
6. EXHIBITION	203
0. POSTSCRIPT	219
<i>Notes</i>	223
<i>Bibliography</i>	226

LIST OF ILLUSTRATIONS

<i>page</i>	
1	<i>The Architect's Dream</i> , painting by Thomas Cole, 1840 source: http://www.explorethomascole.org/tour/items/91
11	<i>November 15, 2008</i> , from notebook of author
13	<i>November 27, 2008</i> , from notebook of author
15	<i>December 2, 2008</i> , from notebook of author
17	<i>April 28, 2009</i> , from notebook of author
19	<i>November 11, 2009</i> , from notebook of author
21	<i>November 24, 2009</i> , from notebook of author
23	<i>November 24, 2009</i> , from notebook of author
25	<i>December 1, 2009</i> , from notebook of author
27	<i>January 20, 2010</i> , from notebook of author
29	<i>February 1, 2010</i> , from notebook of author
31	<i>February 10, 2010</i> , from notebook of author
33	<i>February 10, 2010</i> , from notebook of author
35	<i>February 12, 2010</i> , from notebook of author
37	<i>February 16, 2010</i> , from notebook of author
39	<i>March 10, 2010</i> , from notebook of author
41	<i>March 26, 2010</i> , from notebook of author
43	<i>May 4, 2010</i> , from notebook of author
45	<i>May 9, 2010</i> , from notebook of author
47	<i>May 16, 2010</i> , from notebook of author
49	<i>October 5, 2011</i> , from notebook of author
51	<i>October 5, 2011</i> , from notebook of author
53	<i>October 5, 2011</i> , from notebook of author
55	<i>October 7, 2011</i> , from notebook of author
58	<i>Screen captures of first Rhino model; CNC routed mold; Wax casting</i> by author, <i>Sept. 7 to Oct. 25, 2009</i>
59	<i>Screen captures of Rhino model of 2nd mold; Plastic 3D print of mold; Wax casting</i> by author, <i>Sept. 29 to Nov. 10, 2009</i>

- 60 *3D printer printing model; Finished print of model*, by author, Nov. 12 to Nov. 17, 2009
- 61 *Screen captures and quick renders of various models in Rhino*, by author, Apr. 4 to May 11, 2010
- 62 *Quick renders of various models in Rhino*, by author, Apr. 7 to May 10, 2010
- 63 *Quick renders and screen captures of various models in Rhino*, by author, Apr. 28 to May 10, 2010
- 64 *Quick renders of various models in Rhino*, by author, Apr. 26 to May 10, 2010
- 65 *Quick renders of various models in Rhino*, by author, May 4 to May 11, 2010
- 70 1.01 *Untitled (Sheet)*, photograph by Elise Rasmussen, 2007, part of her series “Stendhal Syndrome”; source: <http://www.eliserasmussen.com/work/stendhal>
- 71 1.02 *Untitled (Pillow)*, photograph by Elise Rasmussen, 2007, part of her series “Stendhal Syndrome”; source: <http://www.eliserasmussen.com/work/stendhal>
- 71 1.03 *Untitled (Foot)*, photograph by Elise Rasmussen, 2007, part of her series “Stendhal Syndrome”; source: <http://www.eliserasmussen.com/work/stendhal>
- 74 1.04 *Nova Pulcherrimae Civitas Florentiae*, illustration by Stefano Bonsignori, 1584 (Museo di Firenze com'era, Florence); source: *Florence: The City and its Architecture*, by Richard J. Goy, 2002, p.73.
- 75 1.05 *Florentia*, artist unknown, c. 1420 (Bibliothèque Nationale de France, Paris) source: *Florence: The City and its Architecture*, p.57.
- 76 1.06 Aerial photograph of Piazza del Duomo, Florence source: *Firenze, Architettura e Città*, by Giovanni Fanelli, 1973. p.278.
- 76 1.07 Plan showing cathedral and baptistery, Giovanni Battista Nelli, 1733 source: *Florence: The City and its Architecture*, p.90.
- 77 1.08 Axonometric view of historic Florence, showing corridor from SS. Annunziata Basilica to Boboli Gardens; source: *Firenze, Architettura e Città*. p.250, composited by author.
- 79 1.09 *Wade in the Water*, postcard of river baptism from North Carolina, c. 1900 source: http://en.wikipedia.org/wiki/File:River_baptism_in_New_Bern.jpg
- 80 1.10 *The Baptism of Christ*, painting by Andrea del Verrocchio, 1475 (Uffizi Gallery, Florence) source: http://en.wikipedia.org/wiki/File:Andrea_del_Verrocchio_002.jpg
- 81 1.11 Photograph of baptistery interior, looking west toward altar source: *Florence: The City and its Architecture*, p.93.
- 82 1.12 Photograph of dome and cupola from scarsella source: *Le Chiese Di Firenze*, by Alberto Busignani and Raffaello Bencini, 1974, p. 69.
- 83 1.13 Photograph of mosaic dome source: *Florence: The City and its Architecture*, p.95.
- 83 1.14 Photograph of marble mosaic floor tiling, with astrological wheel and outline of octagonal font; source: *Le Chiese Di Firenze*. p.29.
- 84 1.15 Photograph of interior of baptistery, with north doors source: *Le Chiese Di Firenze*. p.15.

- 85 1.16 *Gate of Paradise*, by Lorenzo Ghiberti, 1452
source: *Florence: The City and its Architecture*, p.96.
- 85 1.17 “Adam and Eve” panel, from *Gate of Paradise*, by Lorenzo Ghiberti, 1452
source: http://www.museumsinflorence.com/musei/Baptistry_of_florence.html
- 86 1.18 *Salome with the Head of John the Baptist*, Caravaggio, 1607 (National Gallery, London)
source: [http://en.wikipedia.org/wiki/Salome_with_the_Head_of_John_the_Baptist_\(Caravaggio\)_London](http://en.wikipedia.org/wiki/Salome_with_the_Head_of_John_the_Baptist_(Caravaggio)_London)
- 87 1.19 Eastern facade, baptistry, with *The Baptism of Christ* over doors, by Andrea Sansovino, 1505
source: *Le Chiese Di Firenze*. p.11.
- 87 1.20 *John the Baptist (Reception of his face)*, illustration from Koran
source: <http://www.flickr.com/photos/johnhanscom/3116785332/>
- 90 2.01 Photograph of Orangerie, exterior parterre
source: *In the Garden of the Sun King*, by Robert W. Berger, 1985. Plate 113.
- 90 2.02 Photograph of Orangerie, interior with palm trees
source: *Territorial Ambitions and the Gardens of Versailles*, by Chandra Mukerji, 1997. p.180.
- 91 2.03 Photo of orange & pomegranate trees on Orangerie parterre, by Jacques Dubois, 1983
source: *Versailles, a Garden in Four Seasons*, by Jacques Dubois et al., 2005. Plate 27.
- 91 2.04 Photograph of Cent Marches Staircase
source: *Territorial Ambitions and the Gardens of Versailles*. p.288.
- 94 2.05 Photograph of Orangerie facade, by Jacques Dubois, 1983
source: *Versailles, a Garden in Four Seasons*. Plate 29.
- 95 2.06 *Fireworks on the Canal (18 August 1674)*, engraving by Le Pautre, 1676
source: *Versailles and the Mechanics of Power*, by Arie Graafland, 2003. p.34.
- 95 2.07 Engraving of fireworks at Versailles, by Israel Silvestre
source: *Mirrors of Infinity*, by Allen S. Weiss, 1995. p.90.
- 96 2.08 *Louis XIV*, portrait by Charles Le Brun, 1668
source: *Daily Life at Versailles in the Seventeenth and Eighteenth Centuries* by Jacques Levron, 1968. p.33.
- 97 2.09 Caricature of Louis XIV, cartoon by Thackery
source: *Territorial Ambitions and the Gardens of Versailles*. p.276.
- 97 2.10 *The King in ballet position*, portrait by Hyacinthe Rigaud, 1701
source: http://en.wikipedia.org/wiki/File:Louis_XIV_of_France.jpg
- 98 2.11 Film still from *Marie Antoinette*, written and directed by Sofia Coppola, 2006
source: screen capture by author from dvd.
- 99 2.12 *View of Fountain of Dragons*, engraving by Pierre Aveline, 1686
source: *In the Garden of the Sun King*. Plate 112.
- 99 2.13 *View of Orangerie and Chateau*, engraving by Pierre Aveline, 1686
source: *In the Garden of the Sun King*. Plate 114.
- 100 2.14 Film still from *Marie Antoinette*, Coppola
source: screen capture by author from dvd.

- 101 2.15 Film still from *Marie Antoinette*, Coppola
source: screen capture by author from dvd.
- 102 2.16 Diagram of promenade, by Catherine Szanto, 2010, with base engraving by the French School, 17th c.; source: “*A graphical analysis of Versailles garden promenades*” in *JoLA*, Spring 2010. p. 52.
- 102 2.17 *The Gardens of Le Notre at Versailles*, engraving by Jacques Rigaud, cropped by author
source: *Versailles and the Mechanics of Power*. p.99.
- 103 2.18 *Plan of Versailles*, engraving map of chateau, garden, and surrounding town
source: *Versailles, a Garden in Four Seasons*, pages 22-23.
- 104 2.19 Photograph of the Chateau at sunset, by Jacques Dubois, 1983
source: *Versailles, a Garden in Four Seasons*. Plate 79.
- 105 2.20 Film still from *Marie Antoinette*, Coppola
source: screen capture by author from dvd.
- 106 2.21 Plan of Labyrinthe, engraving by Sebastien La Clerc from *Labyrinthe de Versailles* by Charles Perrault, 1677; source: *Territorial Ambitions and the Gardens of Versailles*. p.284.
- 107 2.22 Photograph of orange trees being put out, Orangerie parterre, by Jacques Dubois
source: *Versailles, a Garden in Four Seasons*. Plate 28.
- 107 2.23 Photograph of Orangerie interior
source: *Glass Houses*, by May Woods, 1988. p.15.
- 110 3.01 *The Fall of Pompeii*, amusement ride, Dreamland
source: <http://talesofthejerseyshore.blogspot.com/2009/09/last-days-of-pompeii-coney-island-style.html>
- 111 3.02 *Fighting the Flames*, amusement ride, Dreamland
source: *Delirious New York: A Retroactive Manifesto for Manhattan* by Rem Koolhaas, 1994. p.57.
- 111 3.03 *Fire and Flames*, amusement ride Luna Park
source: *Amusing the Million* by John Kasson, 1978. p.71.
- 114 3.04 Illustration of Coney Island beach in Harper’s Weekly, 1867
source: *Coney Island: The People’s Playground* by Michael Immerso, 2002. p.17.
- 115 3.05 Bird’s-eye view of Brooklyn and Manhattan, artist unknown
source: *Delirious New York*. p.28.
- 116 3.06 Coney Island Boardwalk, c. 1890
source: *Coney Island: The People’s Playground*. p.44.
- 117 3.07 Midget City, Dreamland
source: *Coney Island: The People’s Playground*. p.70.
- 117 3.08 Illusionist at work on levitation act
source: *Coney Island: The People’s Playground*. p.114.
- 118 3.09 Topsy the Elephant, 1903
source: <http://www.westland.net/coneyisland/articles/nickelempire.htm>
- 119 3.10 Elephant Colossus, hotel sections
source: <http://circa71.wordpress.com/2010/06/09/the-coney-island-elephant/>

- 119 3.11 Elephant at the Cairo Pavilion
source: *Coney Island: The People's Playground*. p.55.
- 120 3.12 Coney Island beach, 1930s
source: *Coney Island: The People's Playground*. p.128.
- 120 3.13 Riegelmann Boardwalk, circa 1929
source: *Coney Island: The People's Playground*. p.129.
- 121 3.14 *Coney Island Beach*, Weegee, 1940
source: *Coney Island: The People's Playground*. p.9.
- 122 3.15 Promenading in Luna Park
source: *Coney Island: The People's Playground*. p.62.
- 123 3.16 *View of Luna Park at night, Coney Island, N. Y.*, postcard
source: <http://www.westland.net/coneyisland/articles/images/lu-nightview.jpg>
- 123 3.17 *Luna Park at night*, postcard
source: *Delirious New York*. p.40.
- 124 3.18 *A Coney Island of the Mind*, Lawrence Ferlinghetti, 1958
source: *A Coney Island of the Mind* by Lawrence Ferlinghetti, 1958. cover.
- 125 3.19 The Electric Tower, Luna Park, c. 1905
source: *Coney Island: The People's Playground*. p.63.
- 125 3.20 *Entrance to Luna Park at night, Coney Island*, postcard, c. 1906
source: *Coney Island: The People's Playground*, p7 of "A Coney Island Album", beginning p.56.
- 126 3.21 Cyclone, 1928
source: <http://www.westland.net/coneyisland/articles/nickelempire.htm>
- 127 3.22 *Coney Island Beach*, Dan Cronin, c. 1994
source: *Coney Island: The People's Playground*. p.182.
- 127 3.23 Parachute tower ride
source: <http://www.westland.net/coneyisland/articles/nickelempire.htm>
- 130 4.01 Generalife garden, photograph by Ferdinand Werner
source: *Die Alhambra Zu Granada* by Jules Grécy and Ferdinand Werner, 1990. Plate 75.
- 131 4.02 Tower of the Captive and Tower of the Infantas from Generalife, Ferdinand Werner
source: *Die Alhambra Zu Granada*. Plate 74.
- 134 4.03 Partial plan of Alhambra, photograph by Ferdinand Werner
source: *Die Alhambra Zu Granada*. frontplate.
- 135 4.04 Tower of the Infantas, interior
source: *The Alhambra* by Oleg Grabar, 1978. p.91.
- 135 4.05 Plan of Alhambra in 1840, drawing by Goury-Jones (Jules Goury and Owen Jones)
source: *Die Alhambra Zu Granada*. Plate 1.
- 136 4.06 Cuarto Dorado, south facade
source: *The Alhambra* by Grabar. p.56.
- 137 4.07 Cuarto Dorado, north facade with portico to Darro Valley, Ferdinand Werner
source: *Die Alhambra Zu Granada*. Plate 9.

- 138 4.08 Muqarna ceiling in the Court of Lions, photograph by Ferdinand Werner
source: *Die Albambra Zu Granada*. Plate 47.
- 139 4.09 Sections, *Court of Lions*, top: North-south section, bottom: East-west section (Goury-Jones)
source: *The Albambra* by Grabar. p.78.
- 140 4.10 View of the Court of Lions from arcade, photograph by Ferdinand Werner
source: *Die Albambra Zu Granada*. Plate 48.
- 140 4.11 Arcade at south side of Court of Lions, photograph by Ferdinand Werner
source: *Die Albambra Zu Granada*. Plate 57.
- 141 4.12 Steamy dome in Bath
source: *The Albambra* by Grabar. p.174.
- 141 4.13 Detail of wall decoration in alcove in Hall of Ambassadors, Ferdinand Werner
source: *Die Albambra Zu Granada*. Plate 16.
- 142 4.14 Court of Lions, looking north
source: *The Albambra* by Grabar. p.125.
- 143 4.15 Court of Lions, looking west
source: *The Albambra* by Grabar. p.79.
- 144 4.16 Decorative tiling in Hall of Ambassadors
source: *Die Albambra Zu Granada*. Plate 17.
- 145 4.17 Ceiling of the Sala de las Camas, main hall of Bath, Ferdinand Werner
source: *Die Albambra Zu Granada*. Plate 30.
- 145 4.18 Niche for water jar at entrance to the Hall of Two Sisters
source: *The Albambra* by Grabar. Plate 92.
- 146 4.19 Section of Bath with small plan, by Goury-Jones (Jules Goury and Owen Jones)
source: *Die Albambra Zu Granada*. Plate 27.
- 147 4.20 Court of Myrtles, looking north to portico and Tower of Comares, Ferdinand Werner
source: *Die Albambra Zu Granada*. Plate 12.
- 147 4.21 Bath, Sala de las Camas (main hall)
source: *The Albambra* by Grabar. p.74.
- 150 5.01 St. Paul's Cathedral from Bankside Power Station site, 1947
source: *Building Tate Modern* by Rowan Moore and Raymund Ryan, 2000. p.186.
- 151 5.02 Model of Giles Gilbert Scott's final design within site for power station
source: *Building Tate Modern*. p.183.
- 151 5.03 Bankside Power Station at night
source: *Building Tate Modern*. p.189.
- 154 5.04 Turbine Hall before removal of plant, Marcus Leith, 1994
source: *Building Tate Modern*. p.143.
- 154+ 5.05 Photographs, Marcus Leith, 1994.
155 Boiler house after removal of plant. source: *Building Tate Modern*, p.151.
Removal of flooring. source: *Building Tate Modern*, p.145.
Supports for ramp. source: *Building Tate Modern*, p.140.
Construction of ramp. source: *Building Tate Modern*, p.140.

- 156 5.06 *Maryas*, Anish Kapoor, 2002 (Unilever Series installation in Turbine Hall)
source: <http://blogs.thedailybeast.com/daily-pic/2011/7/12/viola-and-kapoor-win-japans-praemium-imperiale>
- 157 5.07 *Shibboleth*, Doris Salcedo, 2007 (Unilever Series installation), photograph by Nuno Nogueira, 2007; source: http://en.wikipedia.org/wiki/File:Shibboleth_Tate_Modern.jpg
- 158 5.08 *House*, (Oct 25 1993- Jan 11 1994) East London, Rachel Whiteread, Chris Hood
source: http://www.flickr.com/photos/spiraling_grace/4377227206/sizes/m/in/photostream/
- 158 5.09 Rendering of Turbine Hall, competition entry by Herzog & De Meuron, 1994
source: *Building Tate Modern*, p.145.
- 158 5.10 *Embankment*, Rachel Whiteread, 2005 (Unilever Series installation), Marius Watz, 2006
source: <http://www.flickr.com/photos/watz/110028496/>
- 159 5.11 *Test Site*, Carston Holler, 2006 (Unilever Series installation), Olli Siebelt, 2006
source: <http://www.flickr.com/photos/shinerclay/296260253/>
- 160 5.12 *The Weather Project*, Olafur Eliasson, 2003 (Unilever Series installation)
source: http://en.wikipedia.org/wiki/File:Tatemodernpowerstation_.jpg
- 161 5.13 *The Weather Project*, Olafur Eliasson, 2003 (Unilever Series installation)
source: <http://www.eikongraphia.com/?p=1311>
- 162 5.14 Rendered perspective of *Dome Room*, Sir John Soane Museum
source: *Sir John Soane's Museum, London* by Stefan Buzas and Richard Bryant., 1994. p.17.
- 163 5.15 *The Picture-Room*, panels closed & open, Sir John Soane Museum
source: *Sir John Soane's Museum, London*. p.54-55.
- 164 5.16 *Untitled (Hôtel de la Duchesse-Anne)*, J. Cornell, 1957 (Art Institute of Chicago)
source: <http://larocaille.altervista.org/blog/2011/06/13/joseph-cornell/>
- 165 5.17 Sculpture gallery at Tate Modern, Todd Eberle
source: *Building Tate Modern*, p.108.
- 165 5.18 Sculpture in gallery at Tate Modern, Marcus Leith
source: *Building Tate Modern*, p.93.
- 166 5.19 view of Turbine Hall from bridge, Gabriele Basilico
source: *Building Tate Modern*, p.69.
- 167 5.20 Tate Modern nearing end of construction, Marcus Leith
source: *Building Tate Modern*, p.117.
- 170 6.01 *The pyramids of Saqqara seen from the Nile*
source: *Monuments of Egypt: The Napoleonic Edition* eds. Charles Gillispie and Michel Dewachter, 1987. Vol.V, Pl. 2.
- 171 6.02 *View of the Great Pyramid at sun rise*
source: *Monuments of Egypt: The Napoleonic Edition*. Vol. V, Pl.9.
- 171 6.03 *View of the Second Pyramid from the east*
source: *Monuments of Egypt: The Napoleonic Edition*. Vol. V, Pl.10.
- 174 6.04 *Plan of Giza Complex*, by P. Smyth
source: *The Egyptian Pyramids: A Comprehensive, Illustrated Reference* by J. P. Lepre, 1990. p.129.

- 175 6.05 *General plan of Memphis and surroundings*
source: *Monuments of Egypt: The Napoleonic Edition*. Vol. V, Pl.1.
- 176 6.06 *Inside the Grand Gallery, upper tier and lower tier*
source: *Monuments of Egypt: The Napoleonic Edition*. Vol. V, Pl.13.
- 177 6.07 *Sections of Grand Gallery, including King's Chamber and Antechamber*
source: *Monuments of Egypt: The Napoleonic Edition*. Vol. V, Pl.15.
- 177 6.08 *Section of Great Pyramid, before discovery of air shafts and subterranean chamber*
source: *Monuments of Egypt: The Napoleonic Edition*. Vol. V, Pl.14.
- 178 6.09 Diagram showing relationship of air shafts to constellations
source: <http://www.benpadiah.com/phpBB2/viewtopic.php?t=397>
- 179 6.10 Diagram of Great Pyramid showing major passageways and chambers
source: <http://www.gizapyramid.com/overview.htm>
- 179 6.11 *The King's Chamber*, by J. and M. Edgar
source: *The Egyptian Pyramids: A Comprehensive, Illustrated Reference*. p.93.
- 180 6.12 *Tourists on the Giza Sphinx*, 1890
source: *Building the Great Pyramid* by Kevin Jackson and Jonathan Stamp, 2003, p.89.
- 181 6.13 *Entrance of Great Pyramid*, G. Rawlinson
source: *The Egyptian Pyramids: A Comprehensive, Illustrated Reference*. p.72.
- 181 6.14 *Arab guides helping tourists on the Great Pyramid*, 1850
source: *Building the Great Pyramid*, p.185.
- 182 6.15 'Roden Crater', video still, Erin Shirreff
source: <http://showupnow.wordpress.com/2009/10/26/the-shape-of-time/>
- 183 6.16 *Finished Crater Topo, Roden Crater*, James Turrell, 1985
source: <http://earthworksnearyou.blogspot.com/2009/06/17-days-more-on-james-turrells-roden.html>
- 183 6.17 Diagram of proposed shaping of earth, *Roden Crater*, James Turrell
source: <http://c4gallery.com/artist/database/james-turrell/james-turrell-roden-crater/james-turrell-roden.html>
- 184 6.18 *Roden Crater*, view of sky from inside crater dish, photograph by Paul Schutze, 2006
source: <http://www.paulschutze.com/roden-download.html>
- 185 6.19 *Roden Crater*, corridor to a Sky Space, photograph by Paul Schutze, 2006
source: <http://www.paulschutze.com/roden-download.html>
- 185 6.20 *Roden Crater*, a sky space
source: <http://earthworksnearyou.blogspot.com/2009/04/james-turrell-roden-crater-i-make.html>
- 187 6.21 *Roden Crater*, NE of Flagstaff, Arizona, James Turrell, 1979 to present
source: <http://rodencrater.com/>
- 190 7.01 *Outside Baptistery*, by author, 2010
- 191 7.02 *Inside Baptistery*, four views, by author, 2010
- 192 7.03 *Outside Orangerie*, by author, 2010

193	7.04 <i>Inside Orangerie</i> , four views, by author, 2010
194	7.05 <i>Outside Coney Island</i> , by author, 2010
195	7.06 <i>Inside Coney Island</i> , four views, by author, 2010
196	7.07 <i>Outside Alhambra</i> , by author 2010
197	7.08 <i>Inside Alhambra</i> , four views, by author, 2010
198	7.09 <i>Outside Tate Modern</i> , by author, 2010
199	7.10 <i>Inside Tate Modern</i> , four views, by author, 2010
200	7.11 <i>Outside Pyramid</i> , by author, 2010
201	7.12 <i>Inside Pyramid</i> , four views, by author, 2010
205	<i>Sketches of exhibition ideas, on newsprint</i> , by author, December 3, 2009
206-7	<i>Sketches of exhibition ideas, on newsprint</i> , by author, December 3, 2009
208	<i>Sketches of exhibition (notebooks, newsprint, & Photoshop)</i> , by author, Nov 8, 2009 - Jan 26, 2010
209	<i>Sketch models of exhibition box; felt, cut and sewn</i> , by author, Jan. 25 to July 29, 2010
210	<i>Table prototypes</i> , by author, Feb. 7 to Mar. 17, 2010
211	<i>Tables, before and after paint, tested with object</i> , by author, Sept. 9 to Sept. 16, 2011
212	<i>Photographs of exhibition, general views</i> , by Yiu-Bun Chan, January 13, 2012
213	<i>Photographs of exhibition, general views</i> , by Yiu-Bun Chan, January 13, 2012
214	<i>Photographs of exhibition, detail views</i> , by Yiu-Bun Chan, January 13, 2012
215	<i>Photographs of exhibition, detail views</i> , by Yiu-Bun Chan, January 13, 2012
216	<i>Photograph of exhibition, general view</i> , by Yiu-Bun Chan, January 13, 2012
217	<i>Photograph of exhibition, general view</i> , by Yiu-Bun Chan, January 13, 2012
234-5	<i>List/ chart, on newsprint</i> , by author, May 31, 2010



The Architect's Dream, Thomas Cole, 1840

Jorge Luis Borges's "The Garden of Forking Paths" is the tale of the great grandson of Ts'ui Pên, the Chinese governor of Yunan, who renounced his political office to devote himself to writing a novel of inestimable complexity, and to creating "the garden of forking paths," a labyrinth so intricate that all who enter would be lost within. Centuries later, no trace of the labyrinth exists, and what remains of the novel is deemed totally incoherent. Yet his great grandson finally unravels the mystery: Ts'ui Pên's book and his labyrinth are one – a labyrinth of symbols. The meaning of this labyrinth of labyrinths is time itself. The very incoherence of his novel is due, paradoxically, to its adequacy as an image of the universe; time, permitting every possibility, demands a narrative where every option is maintained, and where no single plot determines the course of events. For time is the possibility of possibility.

Allen S. Weiss

*Mirrors of Infinity: The French Formal Garden and 17th-Century Metaphysics*¹

[1]

DEAR READER,

I am sick of this. I don't like my thesis anymore. I'm not so sure I ever did; or if I can even call this a thesis, or if I can state with confidence that it is, in fact, mine. Can something be yours if you've never truly had it in your sights? Can it just be a feeling, a hope, a vague desire? This thesis just kind of happened (mostly under duress), consolidating into something that has nothing to do with anything anymore.

I suppose you can say we had our moments, my thesis and I. The best of it was when I forgot about it altogether. No, I'm not referring to the amount of time I spent avoiding it, but those times that felt so natural I forgot it was actually a thesis, that I was doing schoolwork, something to be done because it had to be.

If this thesis seems messy and incomprehensible, so are my feelings about architecture. After ten years trying to learn it, 'master' it, come to know and understand it, form my own thoughts and opinions of it, I am tired. The early years were all right – massive doses of information taken in and half-digested, programs to learn, work to do, projects to finish, no

time to think. Feelings of stress, of being overwhelmed, became normal – stress that my work was good, right, beautiful. And eventually the stress became more about logistics (layouts, lines, deadlines) than about the work itself. We trained ourselves to do everything quickly, passably, and in the least amount of time. The magic wasn't exactly gone, but it was buried in other concerns.

When I say I've fallen out of love with my thesis, I really mean architecture. Not buildings, not places, not rooms, not the profession, but architecture, in the broadest sense of the word. It's too large for me, too ungraspable. How can you like something if you don't even know what it is, still can't recognize it after years and years?

This thing is so messy that I don't even know how this letter will fit in. I can appreciate a good mess probably more than most, but this is, in my opinion, not a good mess, especially since I'm in the middle of it. A good mess would've included Gordon Matta-Clark's cut houses. But he's not in here. Lots of good things aren't in here: things close to my heart, things I admire and want to learn from, have learned from. So much missing, too much left out.

Sometimes I think this thesis is about time travel. Wishful thinking, remembering, regrets, questions for a former time. I've looked back to the pyramids, to early Christianity, to other times long gone, looking for how people lived, saw and constructed their world. How they found meaning in things, simple and great, larger and smaller than themselves.

My own time travel begins and ends with 2001, when I was accepted to this school and, without looking, jumped in. Many times since then I've wanted to bail but have been too afraid. There was always this elusive feeling holding me back from taking the real step to leave this burning house. Fear? Pride? Politeness? Is there ever a good time to quit, to walk out with no explanation?

I began the graduate program with the idea that it was my time to forget what I'd learned from school and work. I was going to leave all that baggage behind and focus on what was truly important to me, even if on graduation I'd have to go back to that former self. And so this thesis developed slowly, very slowly, as I tried, simultaneously, to follow rusty intuition and to get this thing to make sense. Of course I wanted to be done as soon as possible. The problem was I had forgotten what drew me to architecture in the first place. I suppose this thesis was supposed to be the way back, the thing that would help me remember.

To remember I went back. Back to iconic places and buildings that were once significant but are now defunct, former shells of what they were. They were as forlorn as I was. They endure, physically or in our memory, but they are not the same. The baptistery, the garden, the amusement park, the bath, the power station turned museum, and the pyramid. One of them was destroyed and replaced with iterations of the same, hoping to remain in the past. Another finds a new use, and new life with it. The rest are now tourist traps, drawing people from all over the world with the promise of a snapshot or souvenir.

For my thesis I plotted to make objects and an exhibition of these objects. In making them I would work out what exactly turned me on about architecture. Exhibiting them, I would be able to show others what I learned. Or at least show them another small side of the thing, the side I was interested in. The trouble lies with the necessity for explanation: for myself, for the objects, for the exhibition. It seems that, in architecture, and maybe everything, all hinges on the explanation. Explanation is the proof of the value of the thing. My struggle over the last year to tie this together into a coherent book is laid out in these pages. I don't know how to explain it. Every attempt feels more and more off track. I doubt that what I've done has any value to anyone but me.

Looking back at what has amassed, any explanation that may arise comes doubly bound with questions: How does architecture work? How do we employ it? How is it experienced? Is it better as an object? So we can possess it, worship it, bury it? Is it ever only innocent space between four walls, ready to be occupied, to protect us, define us? Is it the solid or the void? Is it the thing or the surface of the thing or the thing the thing holds?

When I started I was looking for something greater than myself. And for a certain focus and clarity that would at least get me by to the end of this. I didn't find it but what I've learned is that is all we ever do, and must do. We look back and we look forward. We look around at this world and we just want to know that there is something meaningful and true within us, and more importantly, around us.

Even as I near the end I feel as if I'm only beginning, all the time, as

I have for the past three years. I can't see the end, but I can feel it. The end has been with me since the beginning, just over the horizon. This is me quitting, once and for all - to finish I must quit. Quit looking for architecture and the world in fragments, hoping I'd get closer to a resolution one piece at a time. Finding only questions in pieces and answers in shards. Fragments don't always add up to unified wholes. Or wholes at all. Or maybe it just depends on how you look at it. I'm still looking for that place and time from which it all makes sense.

This thesis became a maze, a labyrinth, a trap. Seeing the same old sights, noting the same old things, growing confident with every parallel but then confused as I pass by the same walls over and over again. For how much longer can I try to puzzle together something, anything, that might make sense, have an answer, possibly 'work'? When in the end, I want to accept that it just doesn't. The pieces are just the pieces. Maybe the only sensible thing about this book is that it doesn't make sense, because that is essentially what drew me to architecture – it was something mysterious, beautiful, and unknown. An incredibly large world, a dream, that promised to satisfy my curiosity – with places, ideas, and images that only made me want more. And I want to see it that way again.

(Why did I shrink all those places down? Not sure.)

[2]

NOTEBOOKS

Before writing, communication is evanescent and local; sounds carry a few yards and fade into oblivion.

James Gleick

*The Information: A History, a Theory, a Flood*²

Nov 15 · 2008 — Saturday

- Precedents for actual book
- Nick Bantock's *The Forgetting Room*
 - *Atlas of Novel Tectonics* - Reiser & Umemoto

... and so on

inside here another world

Nov 15, 2008 - Saturday

Precedents for actual trade

- Nick Bantock's The Forgetting Room
- Atlas of Novel Textures - Reyes & Utaghmoto

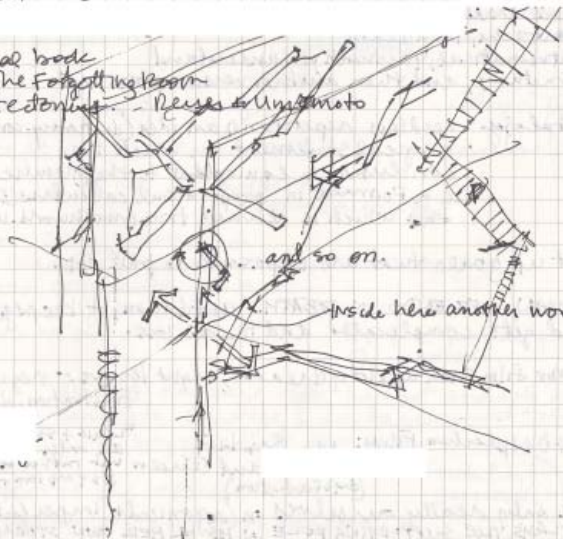

and so on.

inside here another world.

November 15, 2008

Nov 27 · 2008 BIG LIBRARY RUN

Hejduk — narrative in architecture

- provides for richness in meaning
- read in many ways
- what is real? what is important?
- subject/object to object to
subject relationship
- expression of architecture/building/
dwelling/habitat is
intimately tied to occupier

projects — Lancaster/Hanover Masque
(community)
— VICTIMS - see Vidler -

"absurd integrity between FORM + FUNCTION
where it's no longer possible to tell
what is being designed — HABITAT
or INHABITANTS, the container or
contents, institution or moral/
political characters themselves."

Dec 1 · 2008 · Monday

What are my obsessions?

artifacts · art + facts
nonsense + sense

time over form,
form over time.

no absolutes, NO ANSWERS

people in interaction w. architecture
incompleteness of human body by
itself.

NOV 27. 2008 BM LIBRARY RUN

- ~~Hejduk~~ Hejduk - narrative in architecture
- provides for richness in meaning
 - read in many ways
 - what is real? what is important?
 - subject/object to object to subject relationships
 - expression of architecture/building
 - dwelling/habitat is intimately tied to experience

projects - Lancaster/Hanover Mosque (community)

- VICTIMS. see Vidler -

"aband integrity between Form + Function where it's no longer possible to tell what is being designed: - HISTORIC or INVASIONS, the container or contents; Institution or moral/political characters themselves."

Dec 1. 2008. Monday

What are my obsessions?

artifacts. art + facts.
nonsense + sense.

time over form,
form over time.

• no absolutes, no answers.

people in interaction w. architecture
in completeness of human body by
itself.

November 27, 2008

Beuys "explaining pictures to a dead hare"

totalising explanations absurdities.
can only explain itself to itself.
speculative and practical
productively collapsed.

traveler in hotel
home is not own
words are not own

take what is the other and move it inwards
incorporating, enveloping, naturalising.

hahaha — Harold Bloom "strong poets make history
by misreading one another, so
as to clear imaginative space for themselves"

virtual = interpretation

Stan Allen
on Hejduk

"Nothing
but
architecture"
- very good

Beny "explaining pictures to a dead hare"

Totalising explanations abundances
can only explain itself to itself.
speculative and practical
productively collapsed.

Stan Allen
on Kefauk

"nothing
but
architecture"
- very good

traveller in hotel
home is not own.
words are not own.

take what is the other and move it inward
incorporating, enveloping, naturalising.

naraha - Harold Bloom "strong poets make history
by misreading one another, so
as to clear imaginative space for themselves"

virtual = interpretation

April 28 · 2009

ETHER - The nothing that connects everything
by Joe Milutis

- Floating signifier p.x
- ether is mediating substance btwn technology, science, spiritualism,
and historical relations between these 3 terms
determines its perfume.
- placeholder, expressing relations as they shift +
transform through time.

Timeline - Pre-Enlightenment - cosmology in science
science becoming rational, separate
from mystical + philosophical.

ENLIGHTENMENT

- ether becomes synonymous w. irrational

April 28, 2009.

ETHER - the nothing that connects everything
by Joe Milutis

- floating signifier p.X
ether is
- mediating substance btwn technology, science, spirituality,
and historical relations between these 3 terms
determines its perfume.
- placeholder, expressing relations as they shift +
transform through time.

Timeline - Pre-Enlightenment - cosmology in science
Science becoming rational, separate
from mystical + philosophical.
ENLIGHTENMENT - ether becomes synonymous w. irrational

April 28, 2009



perfume store
w. scent booths

scent tunnel
· O. Eliasson

fan hole?
inflatable
shell.

mattress
(enclosed
w. curtains)
revolving
shelves



passive/impassive

perfume store
w. scent booths

scent tunnel
- O. Eliason

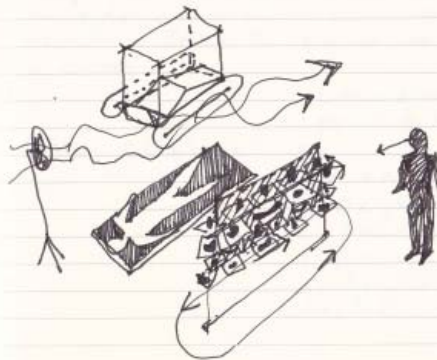
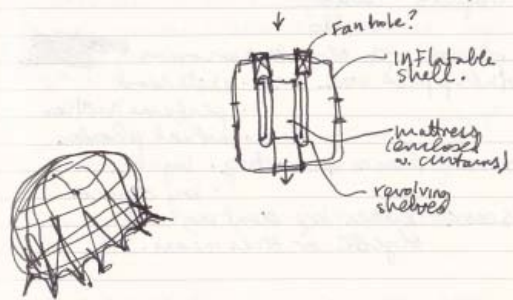

November 11, 2009



John Lilley · isolation tanks.

remember - there are any number
of ways to arrive at the same point
not really any right way so
just decide + go with instincts

November 24 · 2009. tuesday

ILLUSORY INTIMACY

Derek Revington on patio
baptistery vs confessional.

lighting
glass
height
mirror

TEST IT OUT W. MY BODY



body
/bodies know.

peephole,
layers of glass
ghosting.

John Ulrey · isolation tanks.

remember - there are any number
of ways to arrive at the same point
not really any right way so
just decide + go with instincts

~~Nov~~ November 24 · 2009 · Tuesday

Illusory Intimacy.

Derek Carrington on patio
baptistry vs confessional.

lighting
of
house
benefit
mirror

test it out w. my body

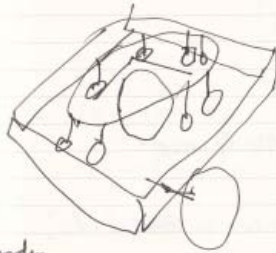

body
baptistry know.



peephole
layers of glass
ghosting.

November 24, 2009



find method to distill smell w. gelatin
(molecular gastronomy)

like cuts of meat

can my entire thesis be lists?



find method to distill smell w. gelatin
(molecular gastronomy)

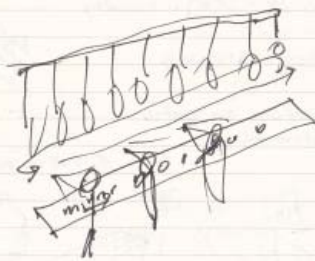

line cuts of meat

can my entire thesis be ~~cut~~ cuts?

November 24, 2009

Things I believe in: (and their opposite)

the possibility of transformation
the presence of things + people
anything can be anything
nothing is fixed or known
interpretation is all
the world isn't necessarily what you feel
or see

I want this exhibit to be
both object and environment
both isolating and intimate

stories of what happened in those places and why they smell this way.
butted up against a wall with photos.
projections on ceiling or on walls or floor?
(inside) scent reflections if long then photos + everything.
too much like a confession booth?
(chair) some more hidden than others? —
lighting structure enclosure objects reflections mirrors @ angles? magnifying glasses

Things I believe in: (and their opposite)

The possibility of transformation
the presence of things + people
anything can be anything
nothing is fixed or known
interpretation is all
the world isn't necessarily what you feel
or see

I want this exhibit to be
both object and environment
both isolating and intimate

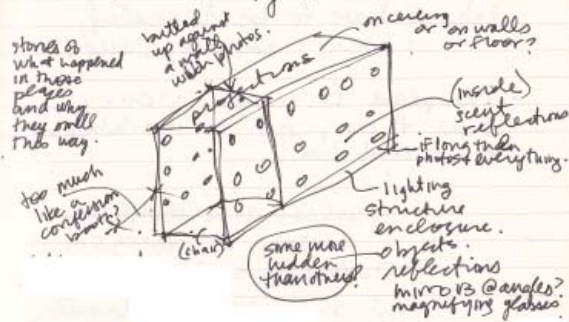

December 1, 2009



tea pot?

light



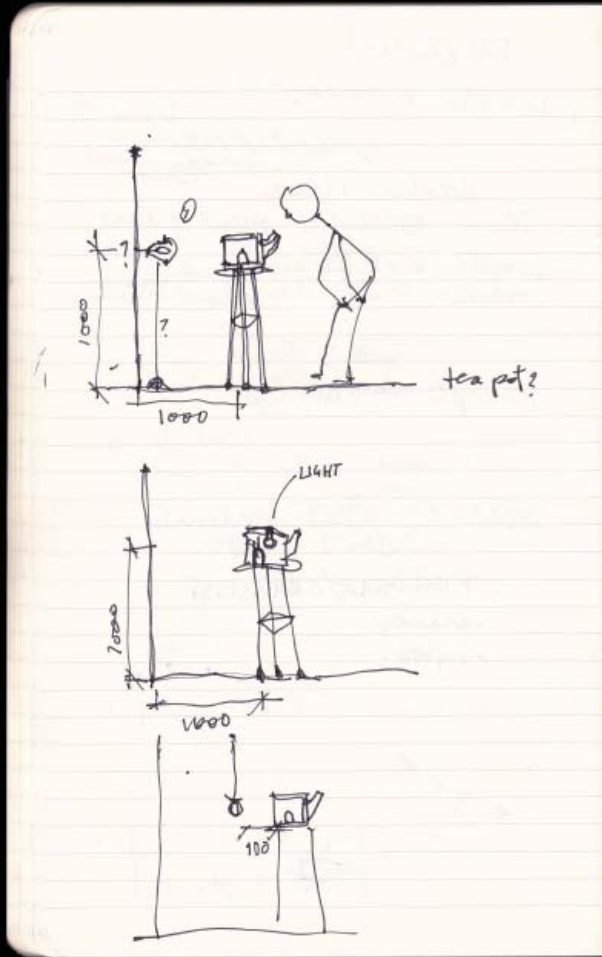

January 20, 2010



relationship of NOSE TO BOX (CLOSENESS) - TO SMELL + MYSTERY

OBJECT TO BOX (HIDING) - FROM SIGHT

BOX TO OUTSIDE OBJECT - VISUAL
(from both sides)

FELT?
INSIDE,
OUTSIDE?

“IDEAL” or possible experience
@ exhibition

MITERED CORNERS.

FELT
COZY.



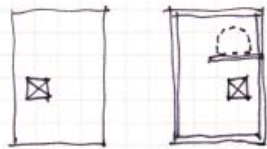

relationship of NOSE TO BOX (CLOSENESS) - TO SMELL + MYSTERY
 OBJECT TO BOX (HIDING) - FROM SIGHT.
 BOX TO OUTSIDE OBJECT - VISUAL 
 (from both sides)

FELT?
 INSIDE,
 OUTSIDE?
 "IDEAL" or possible ~~see~~ experience
 @ exhalation

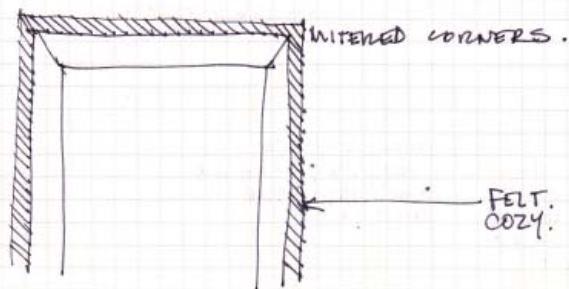



1" opening

1 1/4" opening

too big

FIGURE OUT ON COMPUTER

6 x 7 cm baptistery
wide x tall
1.25 cm x 1.75 cm @ 1/4 scale



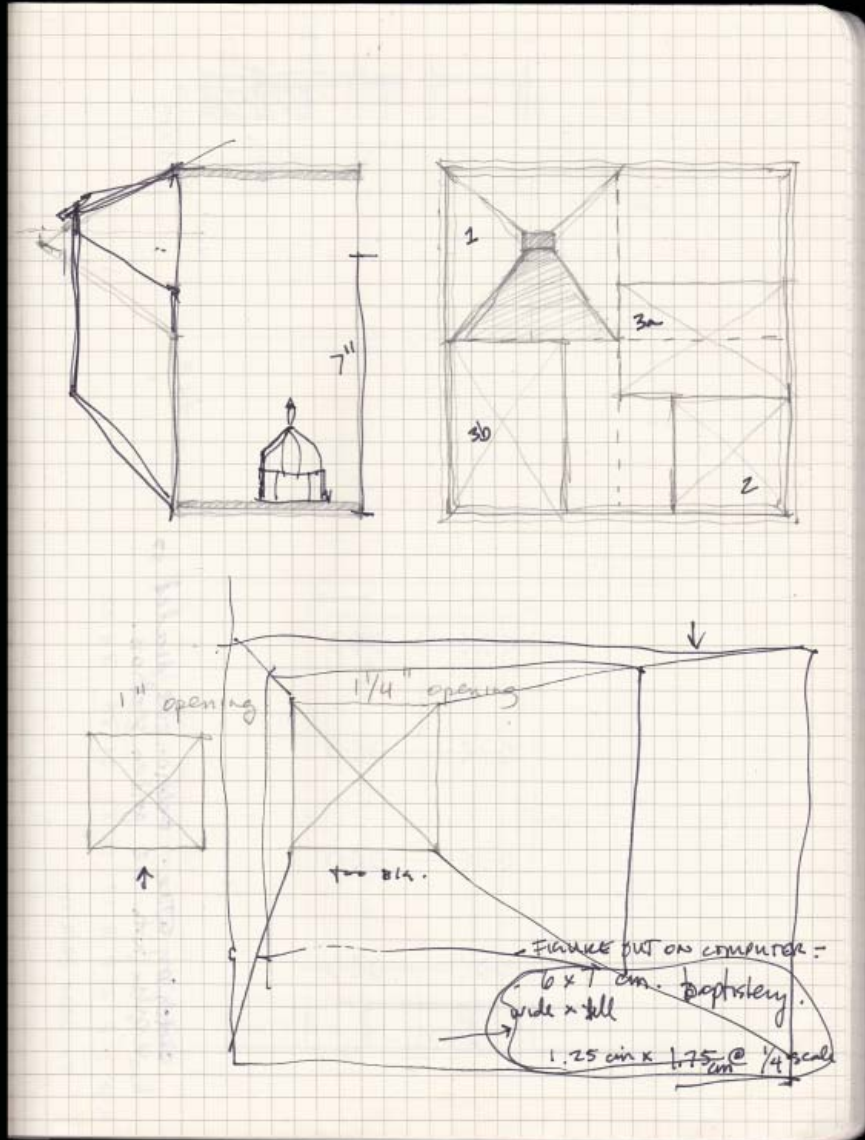

February 10, 2010



GOLDEN SECTION

rects. 3 : 5 5 : 8 8 : 13 13 : 21 21 : 34 34 : 55
proportions?



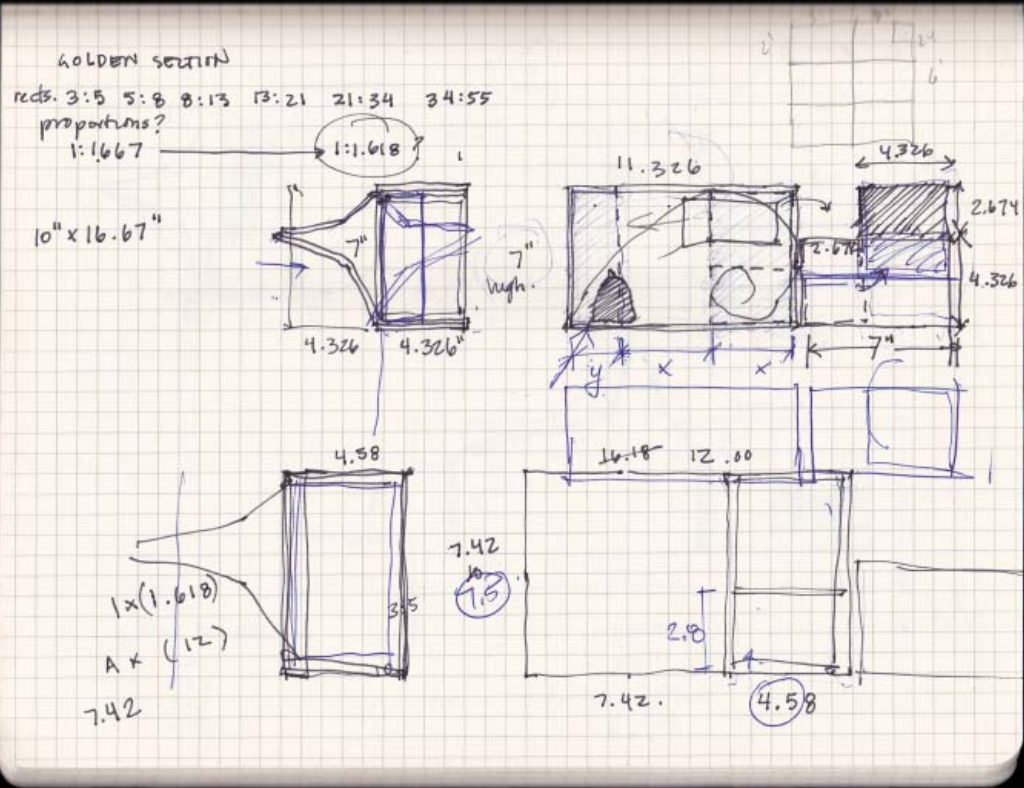

February 10, 2010



PLYWOOD

PLY
FELT

FELT
PLY

THINNER?



centred

FELT ON PLY

PLYWOOD

BASE OF NOSE?

2x2
2x3
3x3
3x5



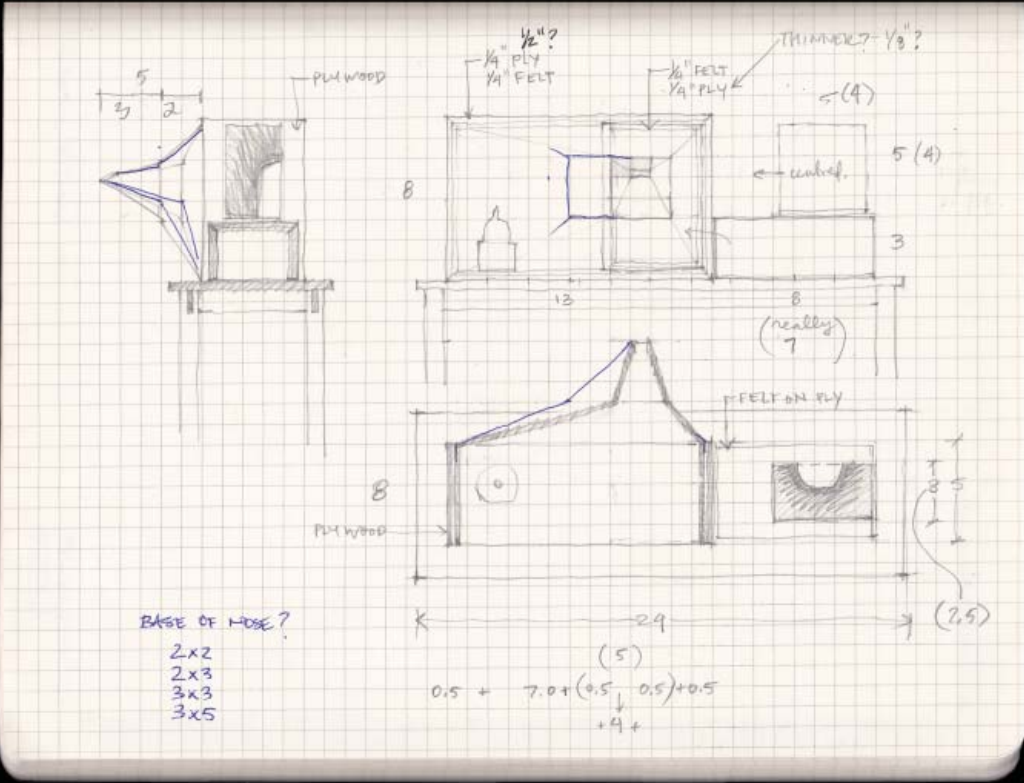

February 12, 2010

Unfinished Dissertation: published in 1998,
BORIS MIKHAILOV started in 1984,
born in 1938

xxxxxxx
xxxxx
xxxxxxx
ie (my crisis situation)
(a strange feeling)

XXXXXXXXXXXXX
XXXXXXXXXXXXX

XXXXXXXXXX

xxxxxxx
xxxxxxxxxxx

HANDWRITTEN NOTES, QUOTES
POETRY, BLUE BALLPT. PEN

ENGLISH
TRANSLATION, 8pt serif

PAGE # - bold sans
serif

ORIGINAL (M's stuff
SCAN OF PAGE glued on back
of someone's unfinished
dissertation)

2 PHOTOS/SNAPSHOTS
OF COMMUNIST RUSSIAN LIFE
BLACK & WHITE, PRINTED IN
~~BATHTUB~~ DARKROOM
TOILET

AT VERY END:

ESSAY

Photography as a
remedy for stammering

TEXT

TEXT TEXT TEXT TEXT

NOTES

UNFINISHED DISSERTATION: published in 1998,
 BORIS MIKHAILOV: started in 1984,
 born in 1938

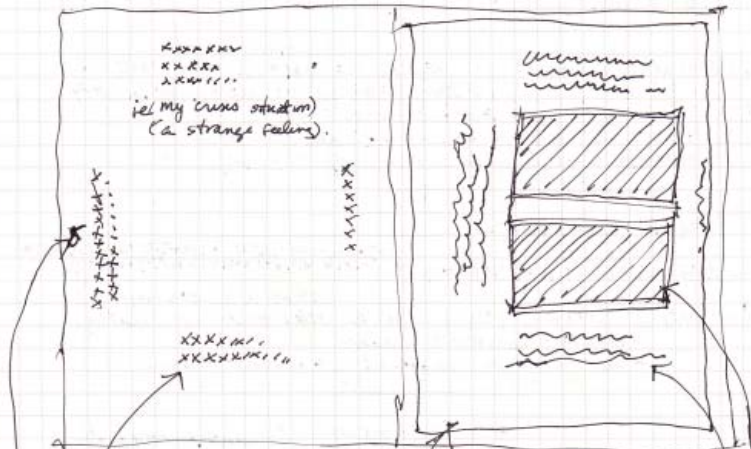

HANDWRITTEN NOTES, QUOTES,
 POETRY, BLUE BALLPT. PEN
 ORIGINAL - Ms stuff
 SCAN OF A PAGE - (found in book
 of someone's unfinished
 dissertation)

ENGLISH
 TRANSLATION, opt scuf
 PAGE # - bold sans
 serif

2 PHOTOS/ SNAPSHOTS
 OF COMMUNIST RUSSIAN LIFE
 BLACK & WHITE, PRINTED IN
 BATHROOM DARKROOM
 TOILET

AT VERY END:

Photography as a
 remedy for Stammering

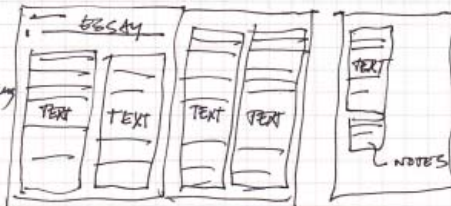

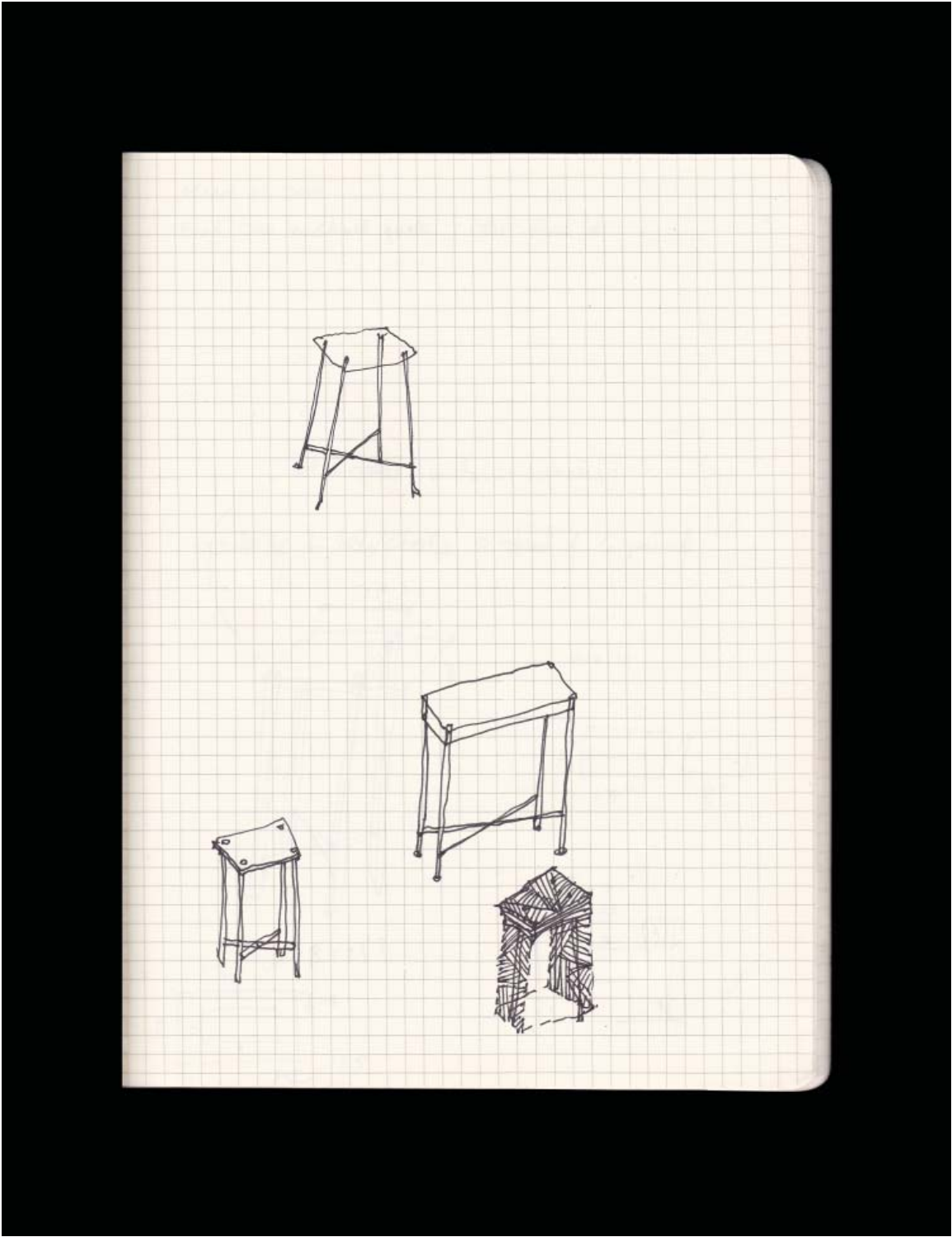

March 10, 2010



- 1 SLABBY?
- 2 FELT
- 3 WOOD
- 4 POWDER

FELT.

CUT OUT TO FIT OPENING.

10mm / 15mm

5mm

50 or 60 mm



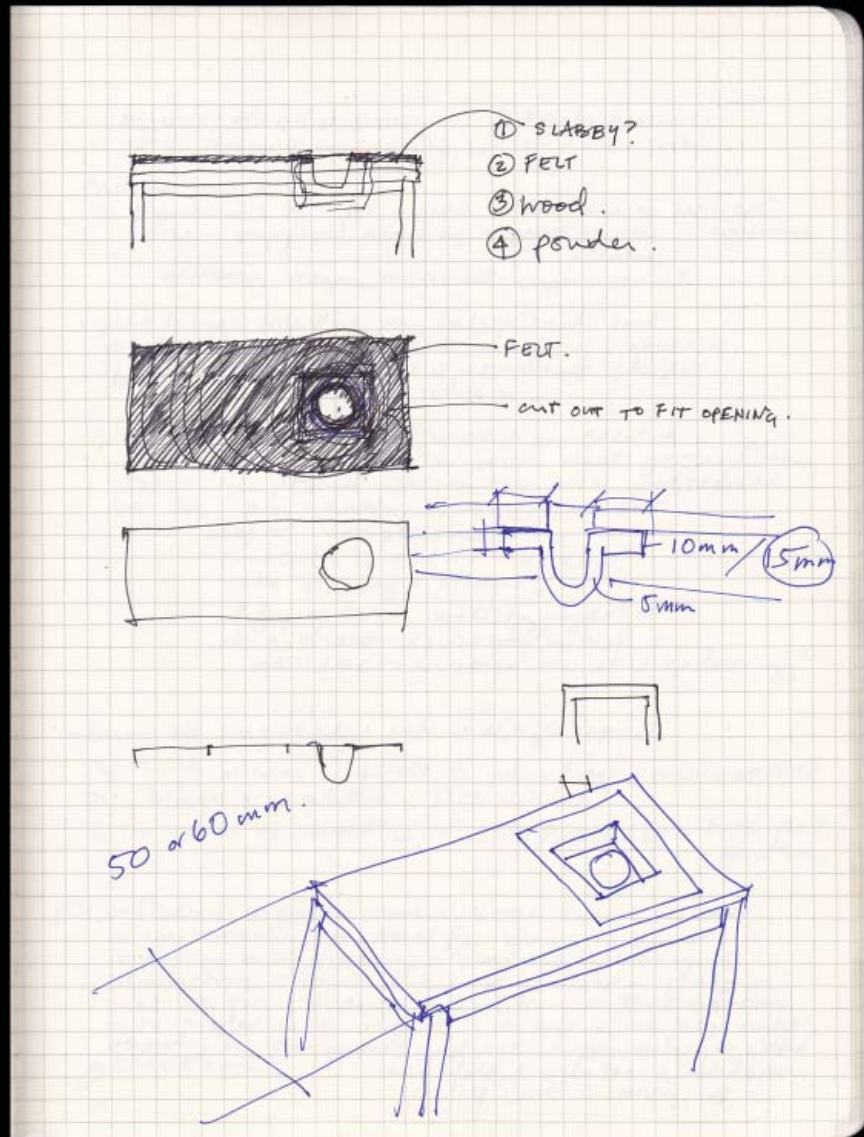

March 26, 2010



Butts up against
another.

outside ???

over
large room

window

window

looking
from here.

just
a bunch
of roofs

Highest.

(don't take too
long!)



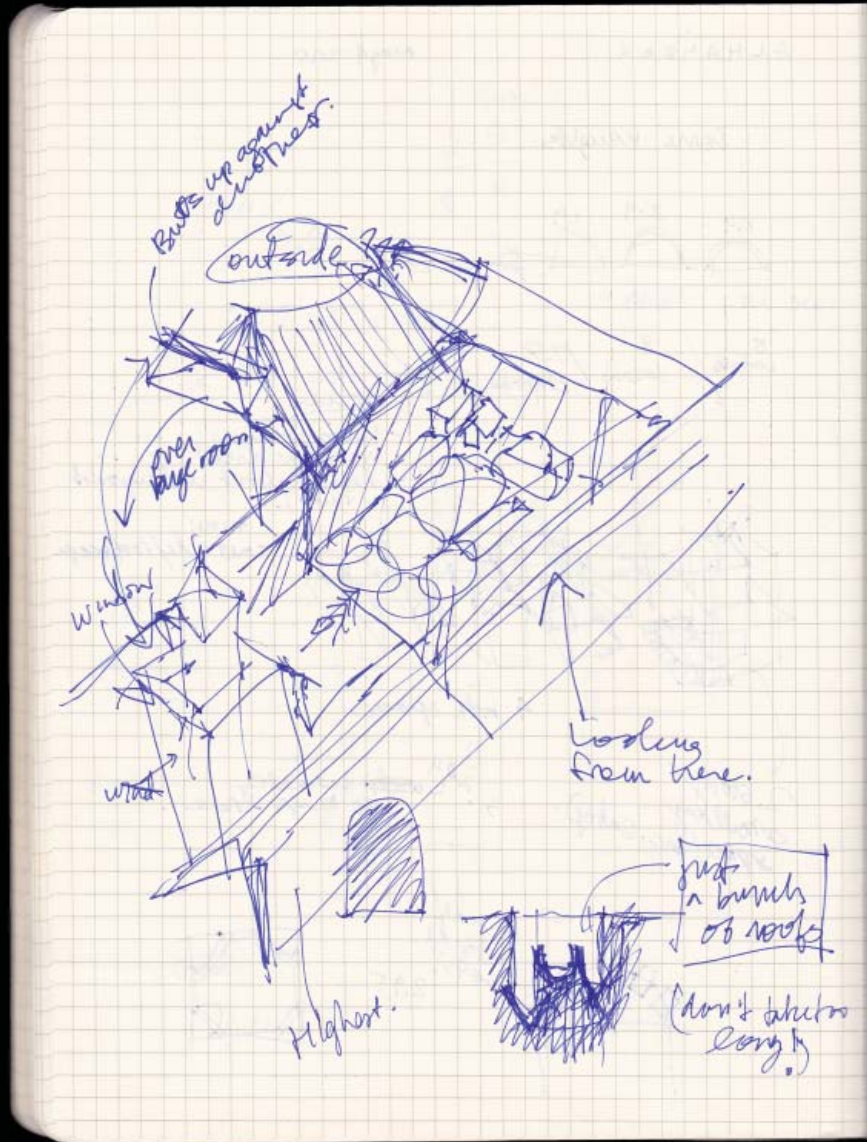

May 4, 2010



The strangeness of this task.
Futility absorbed by doing work
that will not be seen. By
avoiding the centres, the (obvious) point -

talk about the detective work — documenting
these places I've never been to, don't
have much info on. These famous places
that have been visited, “experienced,” by
so many people.

INVERTED

Absurdity of modelling so carefully only the
surface — every edge must match, join,
become a solid.

Also the selective abstraction/deletion,
exaggeration, muting.

then only to 3D print (NO HANDS!) an
object no larger than this book, all the
details blurred, minute,
of powder that will erode + turn to dust &
fall away itself in no time

FOSSILS.



the strangeness of this task.
Futility absorbed by doing work
that will not be seen. by
avoiding the centres, the (obvious) point -

talk about the detective work → documenting
these places I've never been to, don't
have much info on. These famous places
that have been visited, "experienced", by
so many people.

~~inverted~~

Absurdity of modelling so carefully, only the
surface - every edge must match, join,
become a solid -

also the selective abstraction/deletion,
exaggeration, muting.

then only to 3D print (NO HANDS!) at ~~point~~
object no larger than ~~the~~ book, all the
details blurred, minute, turn to
of powder that will erode + dust ~~it~~ &
fall away itself in no time.

POSSIBLES.

May 9, 2010



May 16 . 2010

OK BOX

Felt is 1/4" thick
3' x 72" wide

5 x 13
base of
box

taller box?

- CHECK/MODEL OPTIONS
IN RHINO.

would models
look too small?

do I have enough
felt?



May 16 · 2010

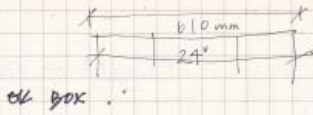

Felt is 1/4" thick
3' x 72" wide

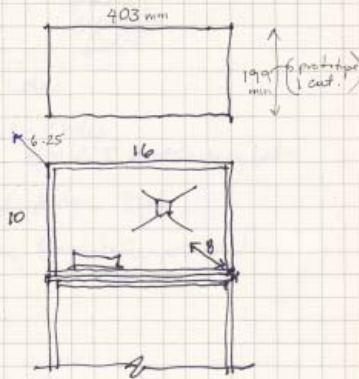
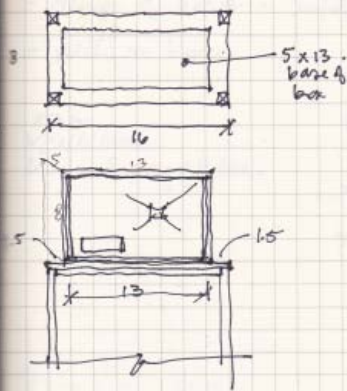

felt
5-8-13



check/make notes IN RHINO.

would models look too small?
do I have enough felt?

(3 ft = 91.4 cm)
Felt = 6 ft x 91 cm.



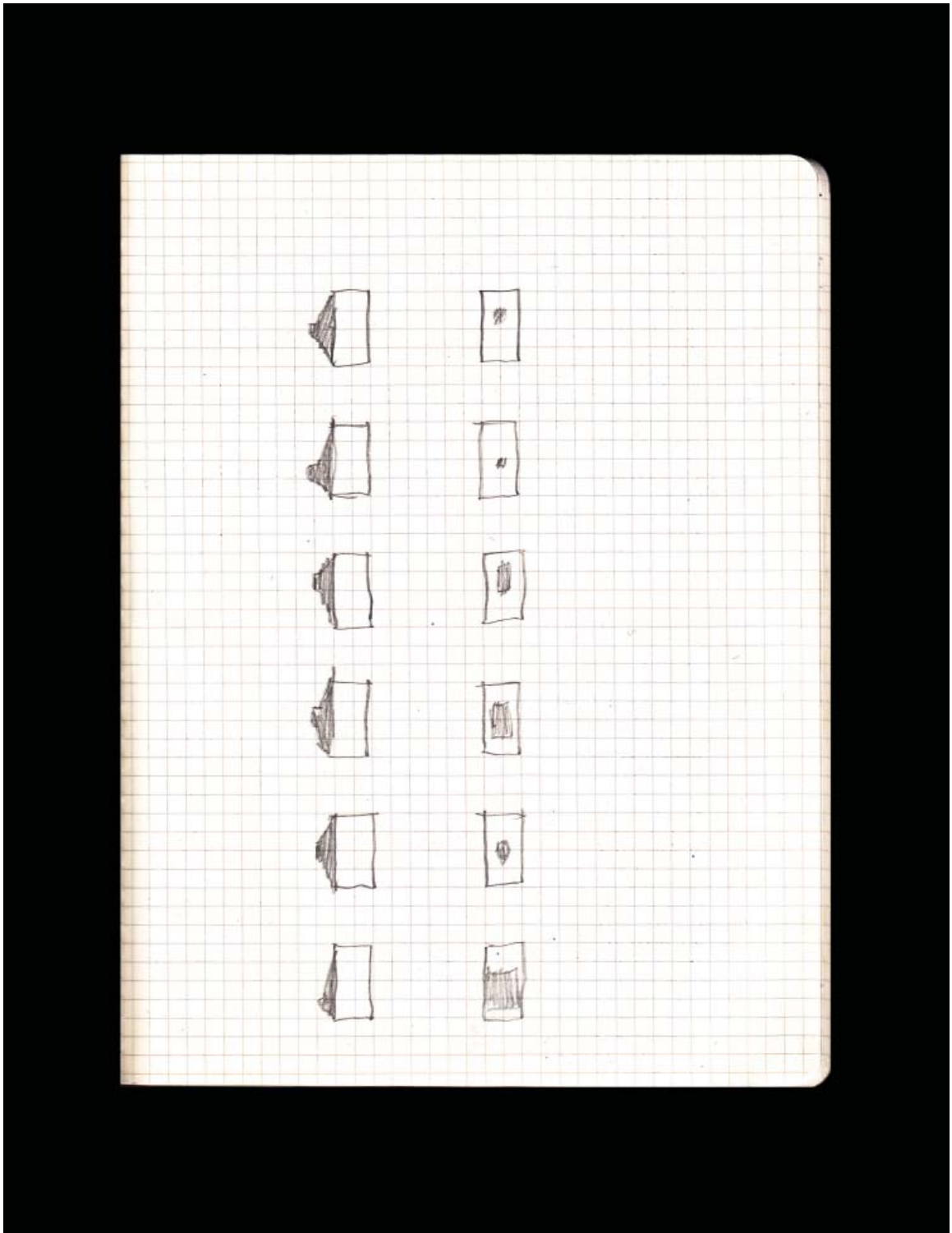

October 5, 2011

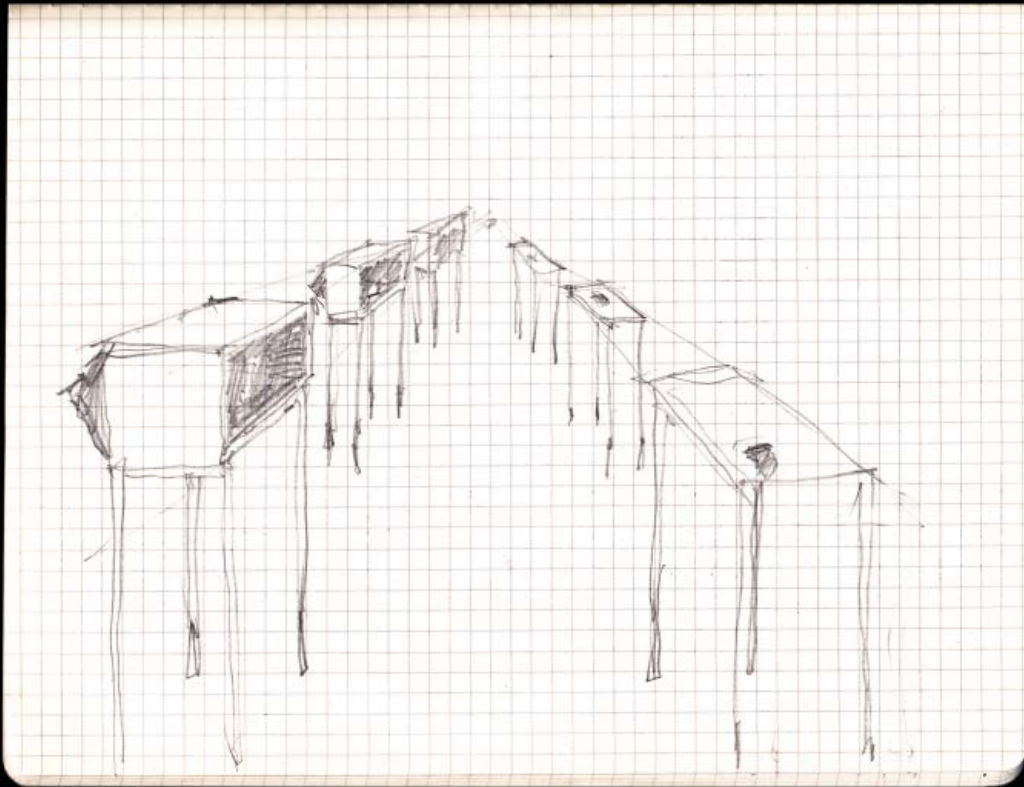

October 5, 2011



A WALL -



FROM HERE MASKED & ANONYMOUS
THEN WE'LL SEE PAIRED TABLES
BEYOND AS WE MOVE AROUND. THEY
FORM AN AISLE / CORRIDOR, WHICH
WE'LL WALK THROUGH.

ENOUGH
SPACE TO
WALK
BETWEEN
TABLES
TOO?

TO STUDIOS

TO STAIRS

OR DO WE SEE CORRIDOR FIRST?

X - where to talk



A WALL -

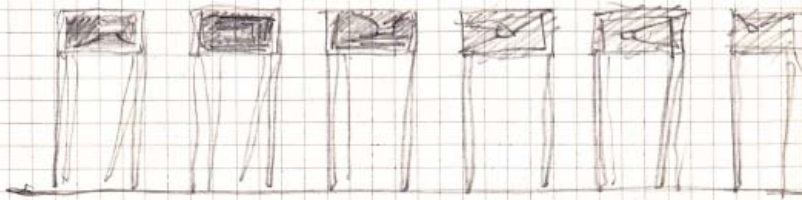

FROM HERE MASKED & ANONYMOUS
THEN WE'LL SEE PAIRED TABLES
BEYOND AS WE MOVE AROUND. THEY
FORM AN AISLE / CORRIDOR, WHICH
WE'LL WALK THROUGH. ENOUGH

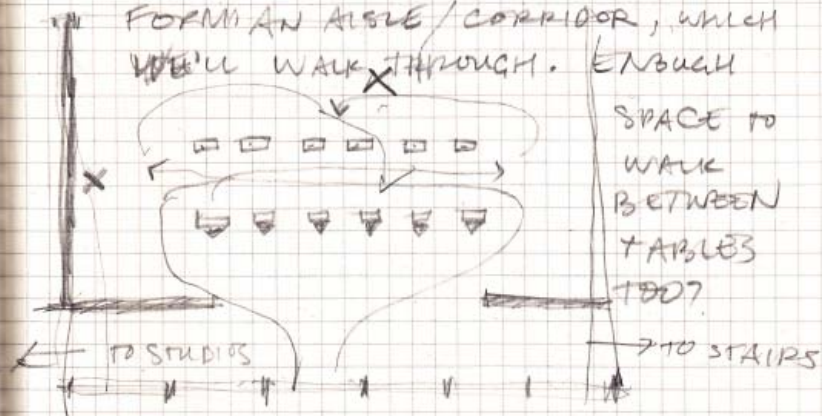

SPACE TO
WALK
BETWEEN
TABLES
ENOUGH

OR DO WE SEE CORRIDOR FIRST?

X - where to talk.

October 5, 2011



AISLE
CORRIDOR
PROGRESSION
PROCESS
BUT -



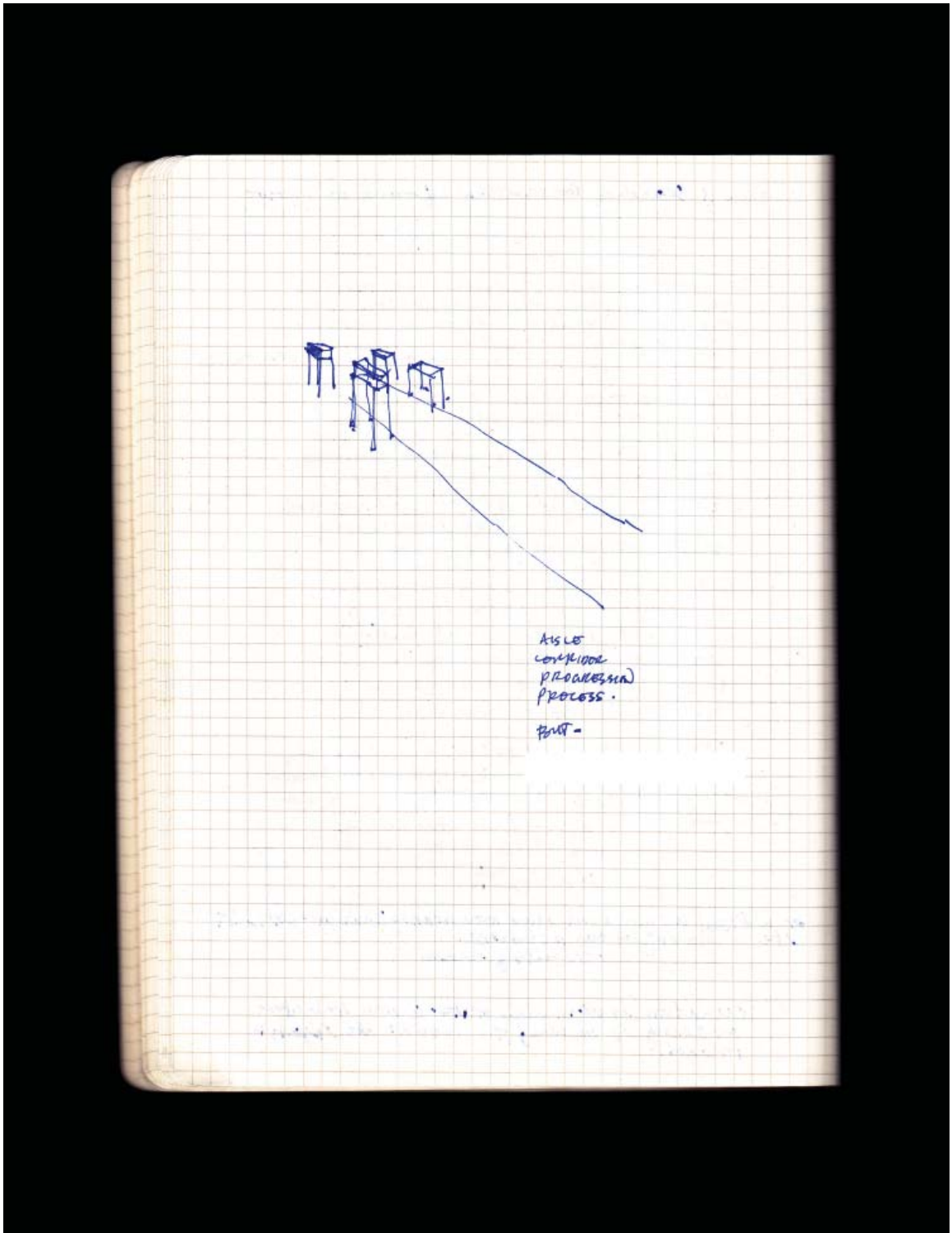

October 7, 2011

[3]

MAKING STUFF

I spent about four months working in this room, casting the piece, and replacing it against the wall as it was cast. I really had no sense of what it was until I relocated it in the studio. By looking at the light switch, I had suddenly realised what I had done. I had made the viewer become the wall. It was a very strange feeling. Somebody asked me why I blocked up the keyhole in the doorway. I had to, otherwise I'd have ended up having to cast the next room, and the outside of the house, and then the street . . . there had to be a point at which things stopped.

Rachel Whiteread on her sculpture *Ghost*
*Working Notes*³

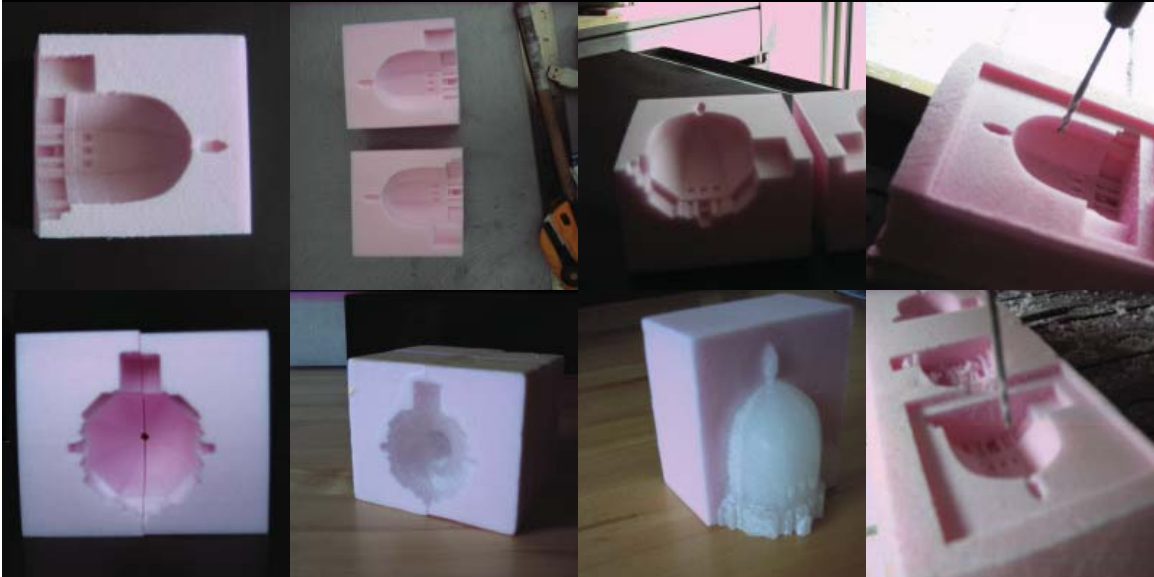
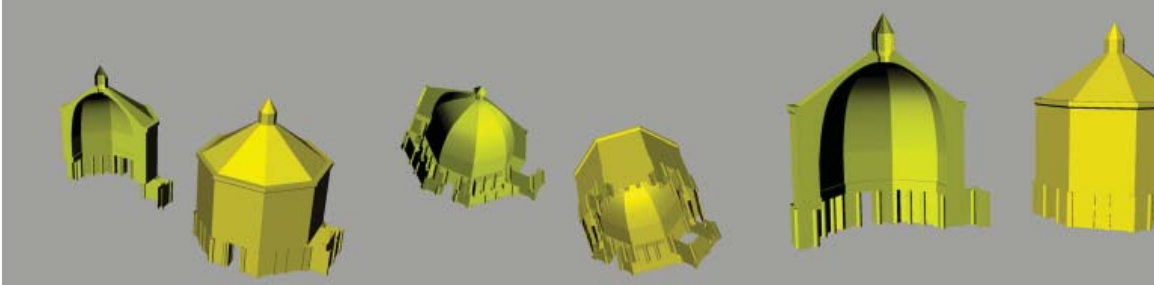

September 7, 2009 to October 25, 2009

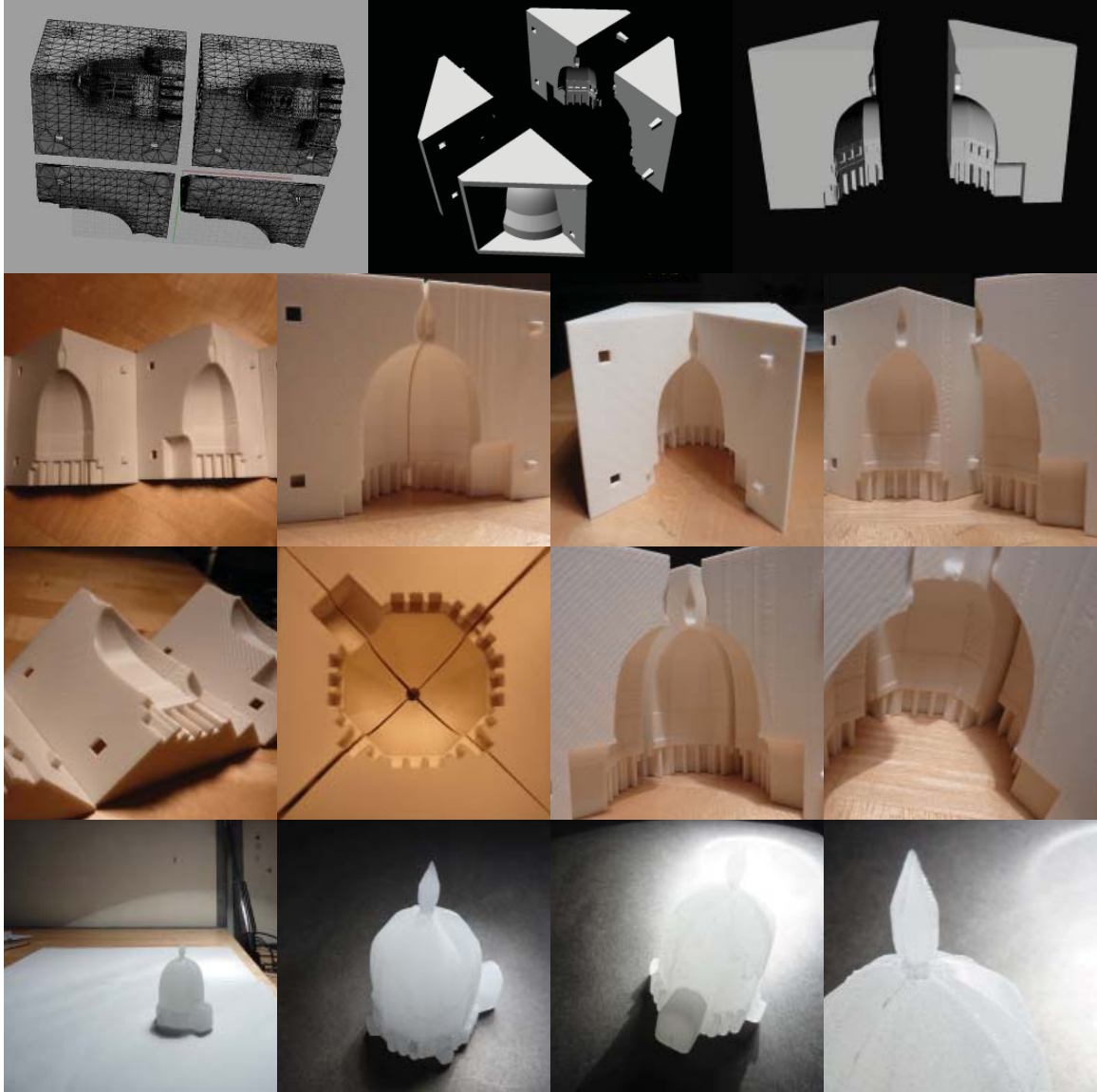

September 29, 2009 to November 10, 2009

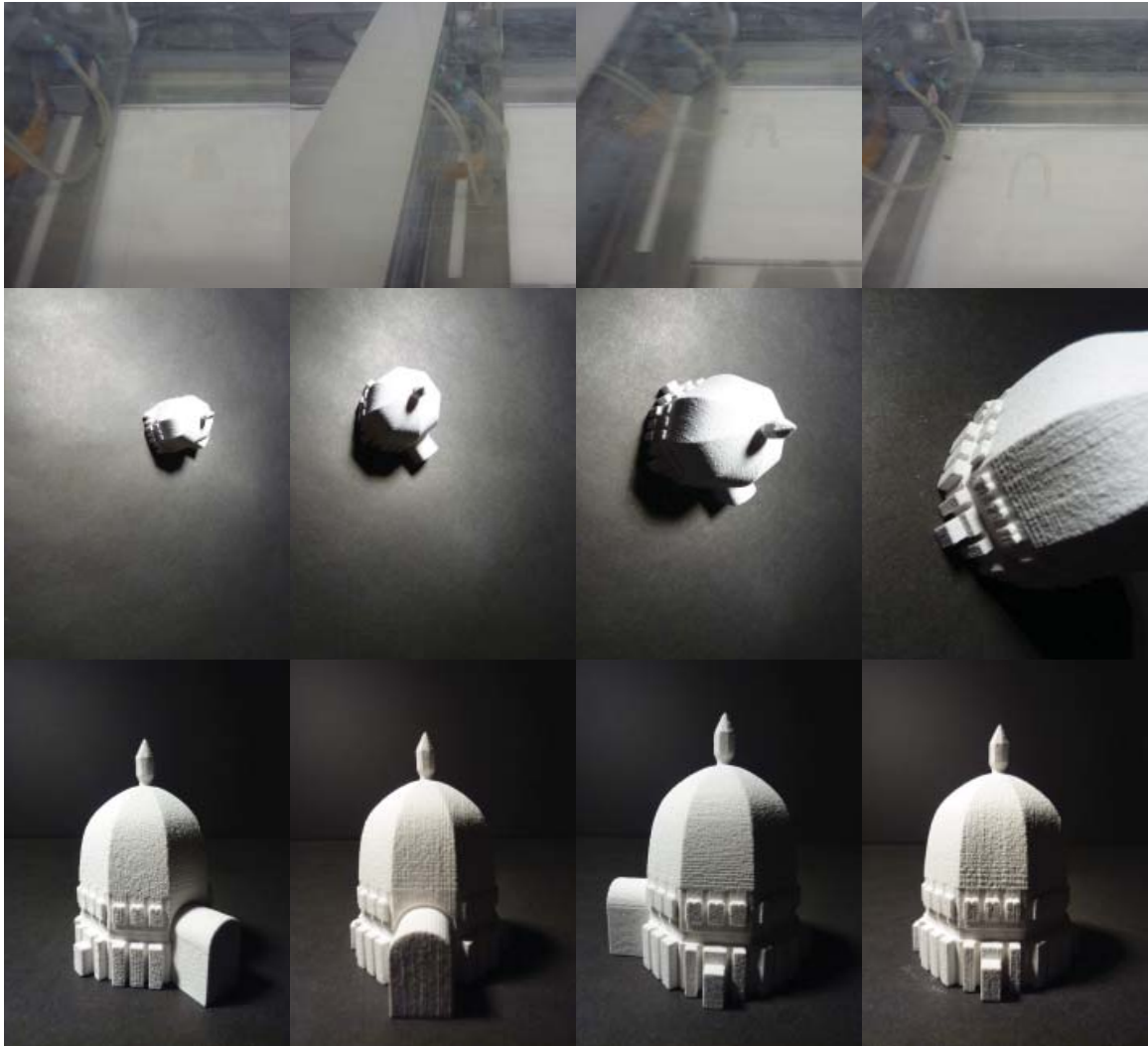

November 12, 2009 to November 17, 2009

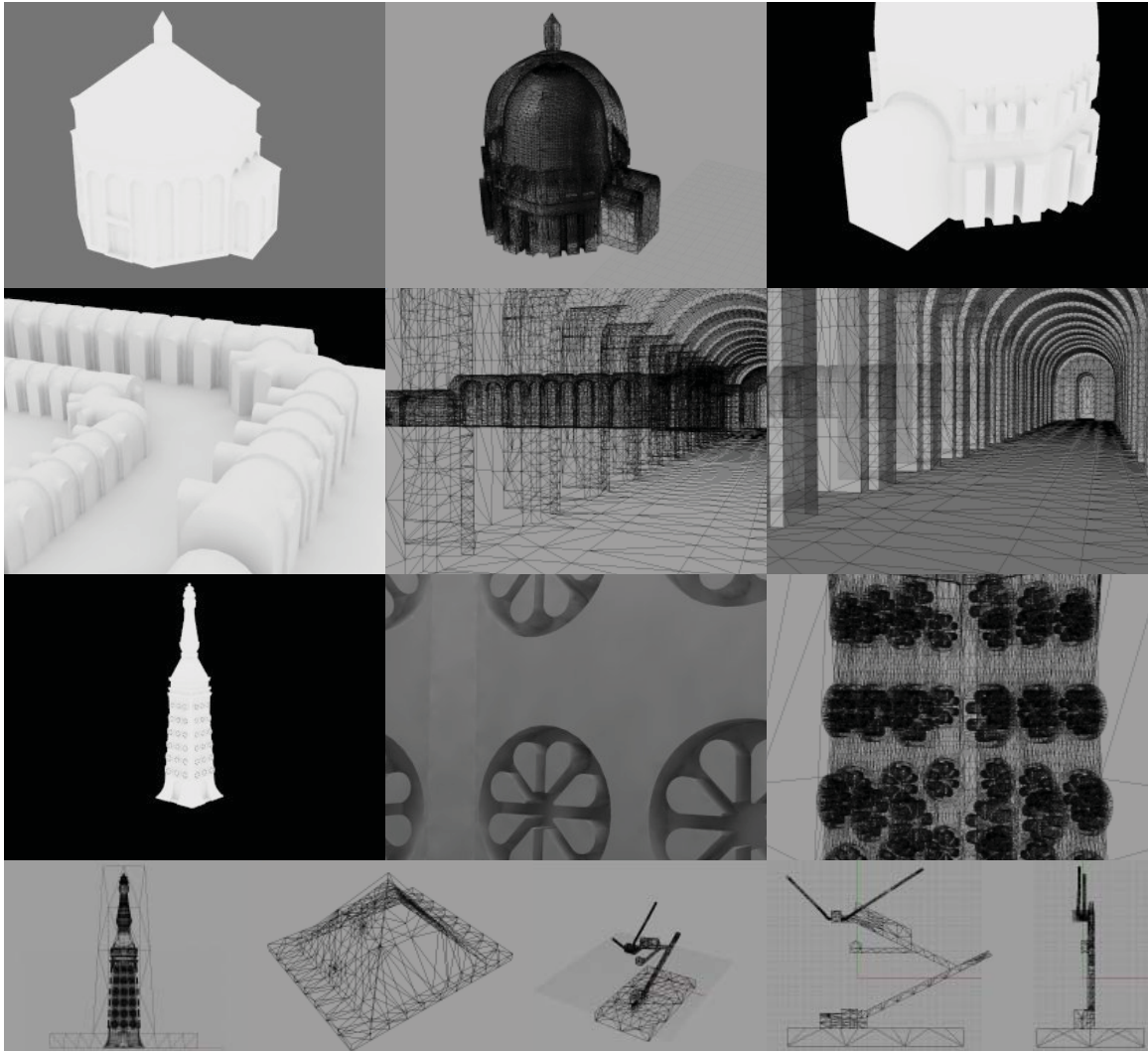

April 4, 2010 to May 11, 2010

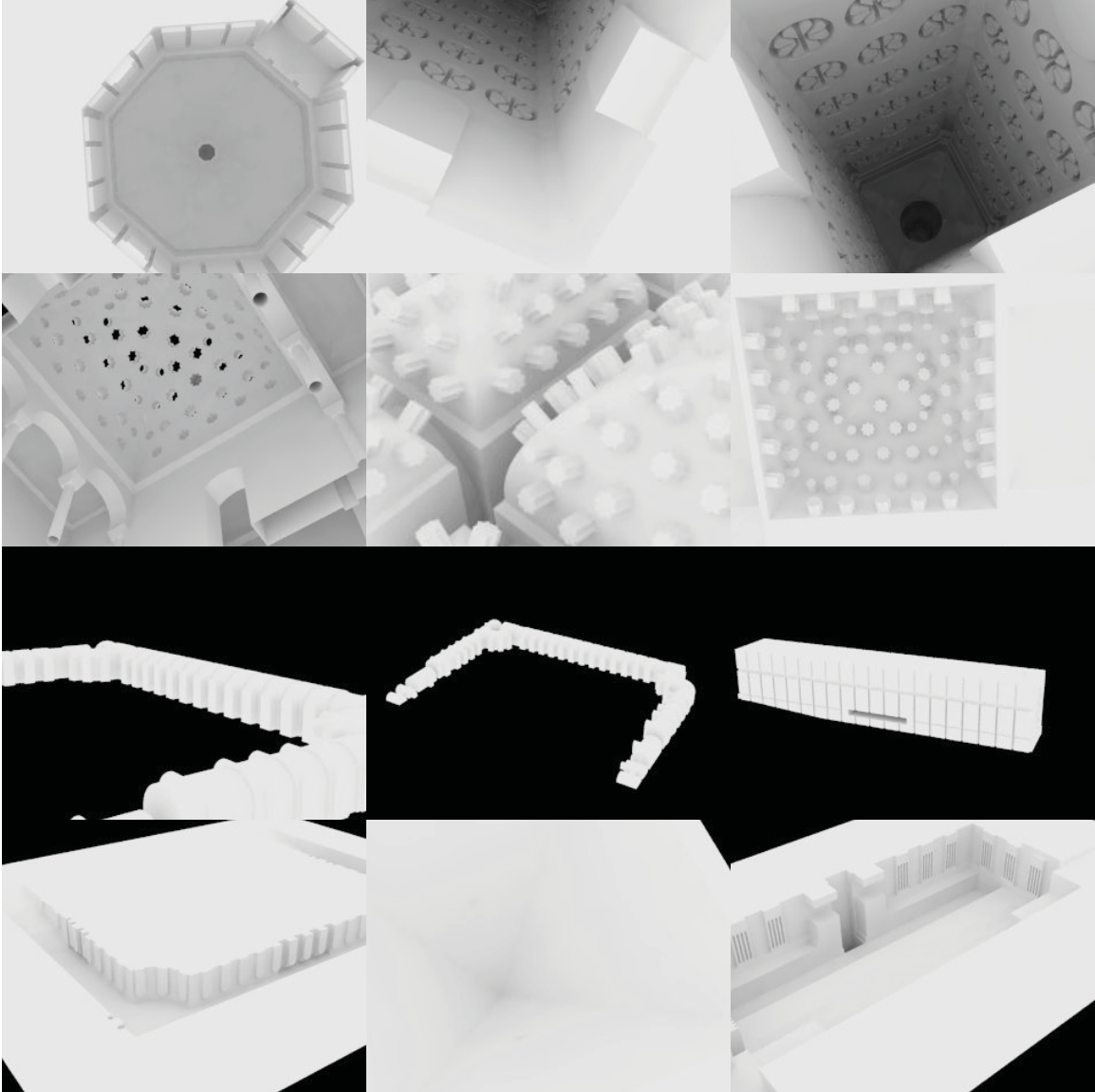

April 7, 2010 to May 10, 2010

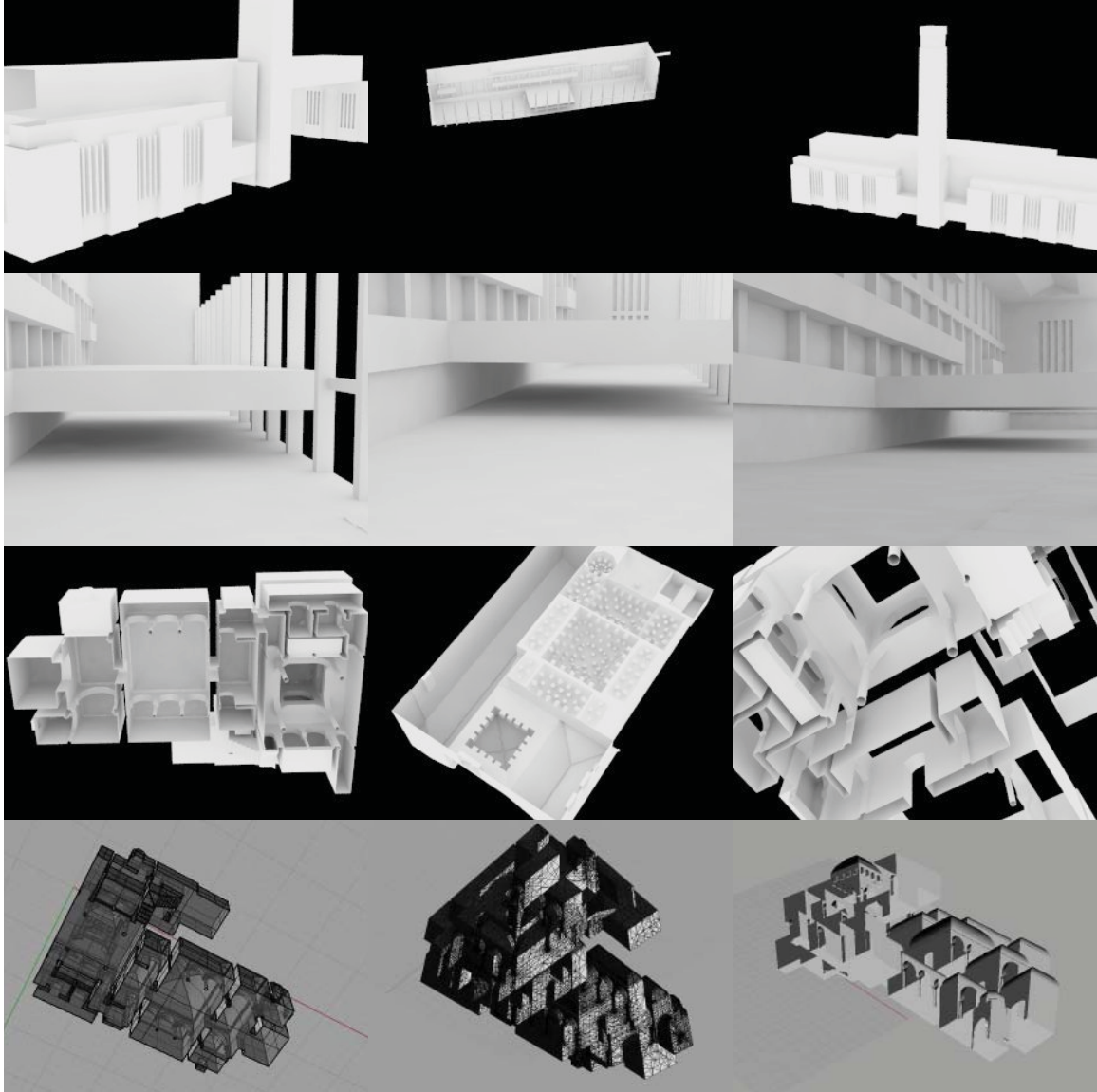

April 28, 2010 to May 10, 2010

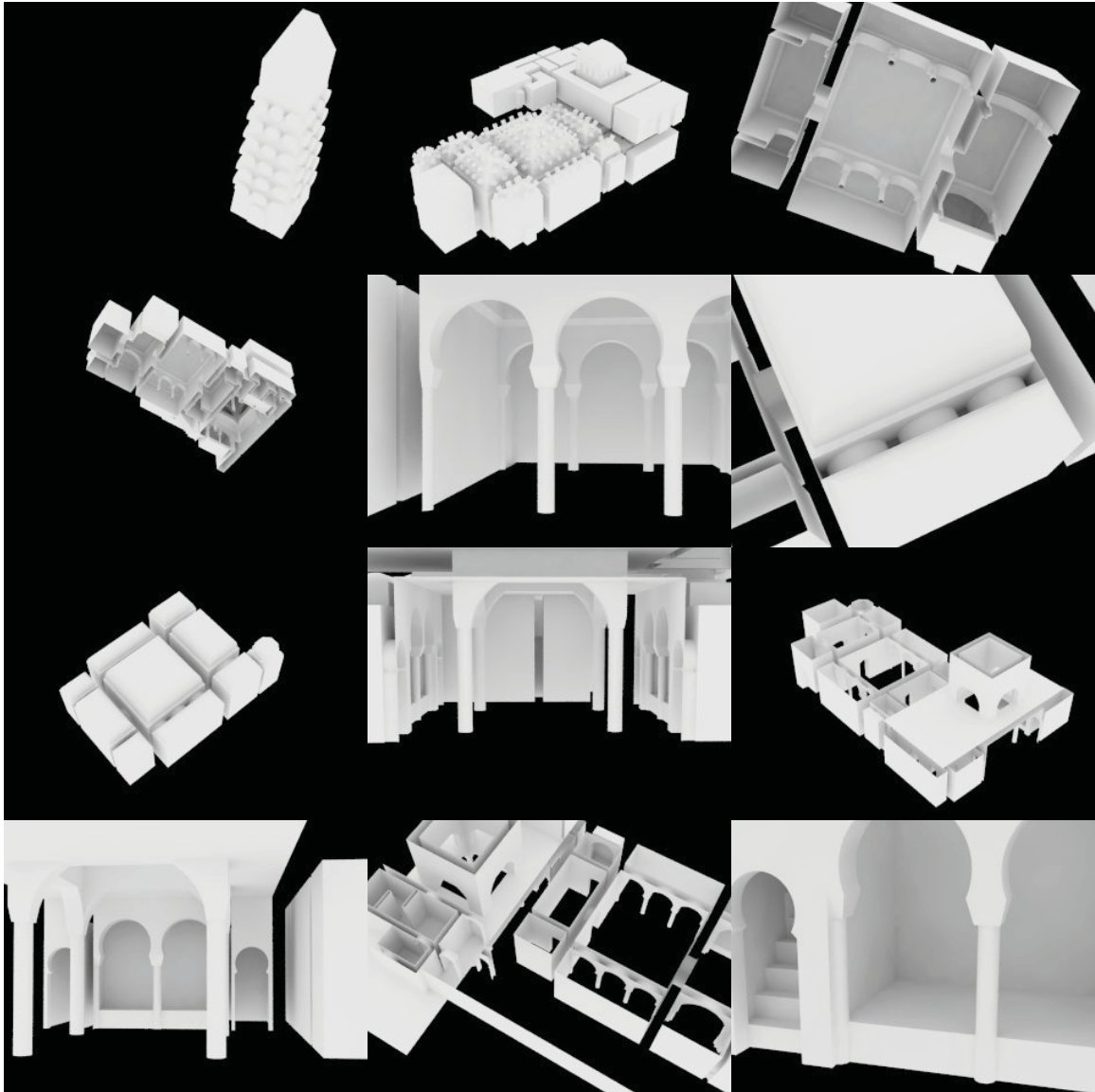

April 26, 2010 to May 10, 2010

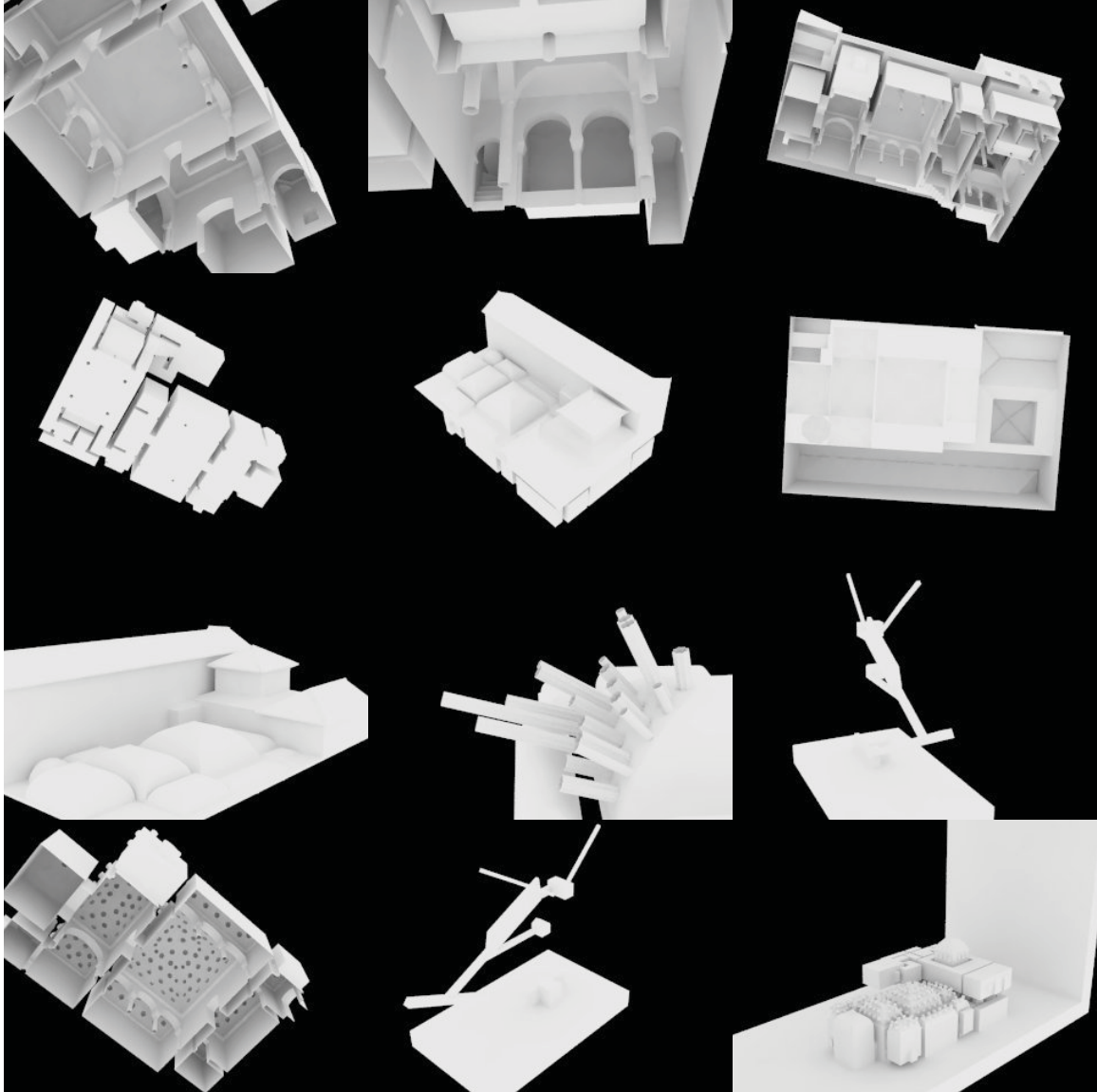

May 4, 2010 to May 11, 2010

[4]

SIX PARTS

He believed in an infinite series of times, in a growing, dizzying net of divergent, convergent and parallel times. This network of times which approached one another, forked, broke off, or were unaware of one another for centuries, embraces *all* possibilities of time. We do not exist in the majority of these times; in some you exist, and not I; in others I, and not you; in others, both of us. In the present one, which a favorable fate has granted me, you have arrived at my house; in another, while crossing the garden, you found me dead; in still another, I utter these same words, but I am a mistake, a ghost.

Jorge Luis Borges
*The Garden of Forking Paths*⁴

THE DOOR

San Giovanni Baptistery, Florence, Italy.

AN UNEXPECTED MADNESS sometimes arises in visitors to Florence.



1.01

- 1.01 *Untitled (Sheet)*
by Elise Rasmussen, 2007
- 1.02 *Untitled (Pillow)*
by Elise Rasmussen, 2007
- 1.03 *Untitled (Foot)*
by Elise Rasmussen, 2007

The Uffizi Gallery, a popular locale for victims of this affliction, houses a recovery bed in a small room off of the gallery's main corridor for those in need of rest or further care at nearby Santa Maria Nuova Hospital.

Elise Rasmussen
*Stendhal Syndrome*⁵



1.02



1.03

WIDELY CONSIDERED THE BIRTHPLACE of the Renaissance, this Italian city is known for its intense concentration of significant art and architecture. There, suddenly surrounded by cultural artefacts that span the city's long history, tourists must be careful not to lose themselves in its museums, palaces, monuments, and churches.

In 1817, the French author Stendhal, for whom the syndrome was posthumously named, found himself reeling in the Florentine cathedral of Santa Croce, where Michelangelo, Machiavelli, and Galileo are buried under a ceiling of Giotto's frescoes. A passage in his book of travel diaries, *Rome, Naples and Florence*, tells of his experience. In an entry dated January 22nd, 1817, he wrote:

I was in a sort of ecstasy, from the idea of being in Florence, close to the great men whose tombs I had seen. Absorbed in the contemplation of sublime beauty. ... I reached the point where one encounters celestial sensations. ... Everything spoke so vividly to my soul. Ah, if I could only forget. I had palpitations of the heart, what in Berlin they call 'nerves.' Life was drained from me. I walked with the fear of falling.⁶

Also known as *Hyperkulturemia* or *Florence Syndrome*, Stendhal Syndrome is a psychosomatic illness that quickens the heart and dizzies the brain, causing

paranoia and disorientation. Even hallucinations and amnesia have been reported by those afflicted by the presence of “too much” beauty.

These symptoms were named for Stendhal in the 1980s by Dr. Graziella Magherini, head of psychiatry at Santa Maria Nuova Hospital, after years of seeing foreign tourists come to her emergency clinic debilitated with panic attacks and such. It is notable that Florence was declared a UNESCO World Heritage site in 1982, no doubt adding to the rush. Magherini’s book, *La Sindrome di Stendhal*, published in 1989, describes and dissects this extreme effect of art on the mind. In 2008 she spoke to journalist Maria Barnas for *Metropolis M* magazine:

The Stendhal Syndrome is a normal aspect of artistic-aesthetic awareness. I have treated 106 cases in the last 10 years. They are very important, because they represent the tip of the iceberg in a process that is in fact very common, striking anyone who goes to see a work of art with an open mind and a desire to feel emotions. I feel it is important to understand the factors that influence us and, indeed, can awaken these reactions in anyone who visits an exhibition or a work of art. Particularly when things go wrong you can learn a lot.⁷

The hospital where Dr. Magherini works is just steps away from Piazza del Duomo, Florence’s spiritual heart and home since the 12th century.



1.04

1.04 *Nova Pulcherrimae Civitas Florentiae*, detail
Stefano Bonsignori, 1584

1.05 *Florentia*, illustrating Ptolemy's *Geografia*
artist unknown, c. 1420

Carved out of the dense city fabric to prominently hold the Santa Maria del Fiore Cathedral (better known as the Duomo), its famous Campanile, and the San Giovanni Baptistery, this site has long formed the core of Christian faith in Florence. From above they appear together as colleagues or family, a unit separate unto themselves in a sea of landmarks.





1.06

1.06 Piazza del Duomo
aerial photograph

1.07 Plan of Piazza del Duomo
Giovanni Battista Nelli, 1733

1.08 SS. Annunziata Basilica to Boboli Gardens
axonometric view

From its position west of the cathedral, the baptistery sets the scene for the first in a series of acts that move eastward, toward Jerusalem. Baptism, the first of the seven Catholic sacraments, is a rite through which a person is incorporated into the spiritual church, and thus takes place before entry into the physical church.

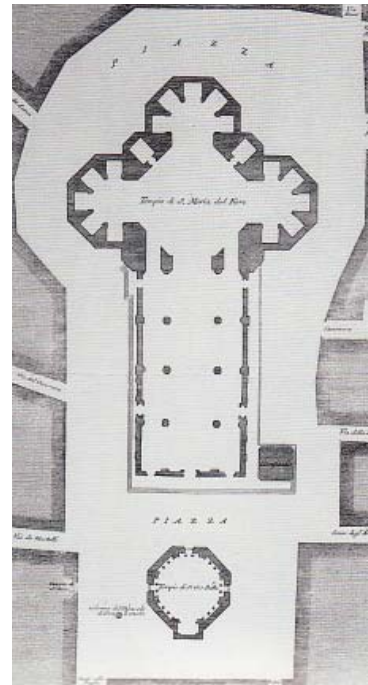

1.07

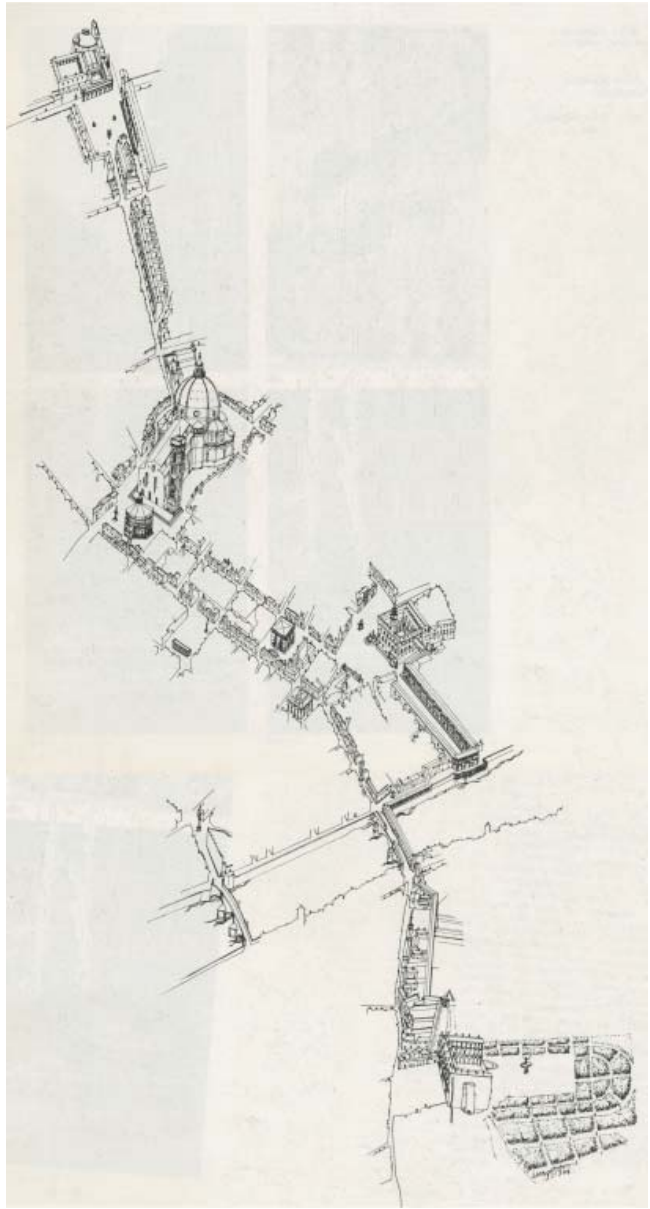

1.08

1.09 *Wade in the Water*, postcard of river baptism
New Bern, North Carolina, c. 1900

The first baptisms were performed in natural waters – rivers, lakes, streams and ponds. The baptizer would stand breathing holy words above while the supplicant lay fully immersed, underwater, momentarily blind and dumb. This descent into water to be born again is described as a mirroring of Jesus' death in *The Ante-Nicene Fathers*, a translation of Early Christian writings.



1.09



1.10

1.10 *The Baptism of Christ*
Andrea del Verrocchio, 1475

1.11 Interior of baptistery
looking west toward altar

This baptism, therefore, is given into the death of Jesus: the water is instead of the burial, and the oil instead of the Holy Ghost; the seal instead of the cross; the ointment is the confirmation of the confession; the mention of the Father as of the Author and Sender; the joint mention of the Holy Ghost as of the witness; the descent into the water the dying together with Christ; the ascent out of the water the rising again with Him.

Constitutions of the Holy Apostles
*Book 3, Section 2: XVII*⁸



1.11

- 1.12 Dome and cupola
from scarsella
- 1.13 Mosaic ceiling of dome
begun c.1270, finished early 14th century
- 1.14 Marble mosaic floor, with astrological wheel
and outline of octagonal font



1.12

A tiny cupola soars above an immense volume of filtered light and floating mosaics. The mosaics depict stories from the Bible, including a most striking Jesus, hovering over the altar, with his angels at the Last Judgement. And below, in the centre of all this circling and spiralling upward, lies the outline of original baptismal font that once welcomed generations of Florentines into the church.



1.13

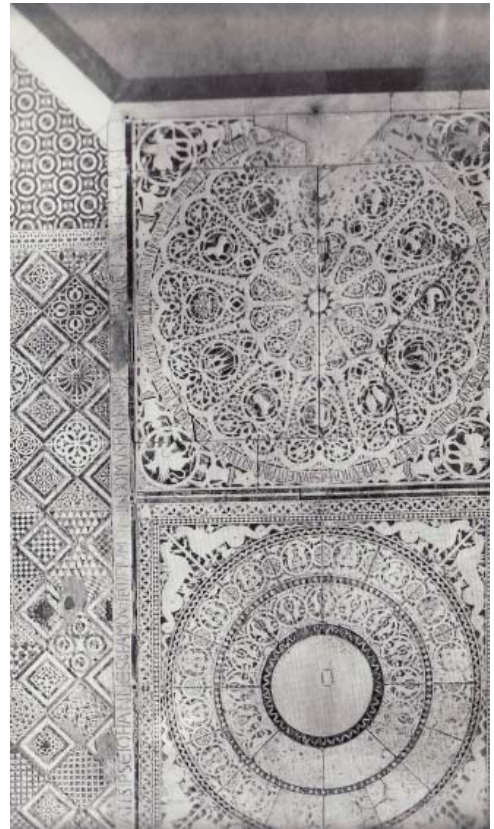

1.14

1.15 Interior of baptistery
looking at north doors

1.16 *Gate of Paradise*
Lorenzo Ghiberti, 1452

1.17 *“Adam and Eve” panel*
Lorenzo Ghiberti, 1452



1.15

Of the baptistery's three sets of grandly wrought doors, the ones that face the Duomo to the east were the last to be completed in 1452. Designed by Lorenzo Ghiberti and made over a period of 27 years, the surface of the *Gate of Paradise* is wholly dedicated to the depiction of ten stories from the Old Testament, all in exquisite relief. Collapsed in the perspective space of the first panel is the story of Adam and Eve told in four parts. In the centre God pulls Eve free of Adam's body while to their right, in an earlier time, he has just created Adam who lies slumped next to a rock. Behind him, in a grove of trees, Adam and Eve stand together in the future, holding an apple with the serpent between them. And in the corner, they nearly spill off the frame as they are finally expelled from the garden of Eden.



1.16



1.17



1.18

1.18 *Salome with the Head of John the Baptist*
Caravaggio, 1607

1.19 Eastern facade, with *The Baptism of Christ*
Andrea Sansovino, 1505

1.20 *John the Baptist (Reception of his face)*
illustration from Koran

The figure of John the Baptist, patron saint of Florence, once overlooked all three of the baptistery's portals: to the east, above the Gates of Paradise, he was seen baptising Jesus; above the north doors he preached to a still audience of two; and over the south doors - whose panels illustrate his life alongside Hope, Faith, Charity, Humility, Fortitude, Temperance, Justice, and Prudence - he knelt to the ground at the moment of his beheading.



1.20

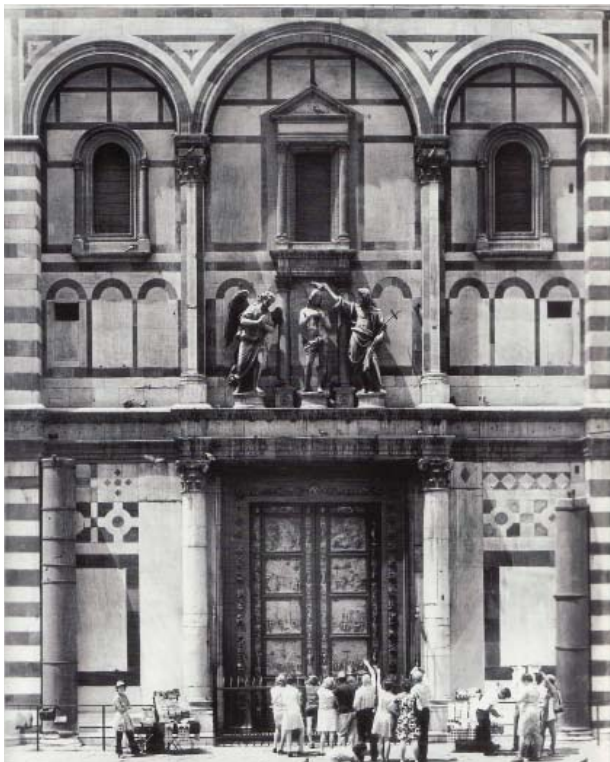

1.19

THE STAGE

The Orangerie at the Court of Versailles, France.

IT CAN BE SAFELY ASSUMED that, at least during the winter months, the most fragrant room in all of Versailles was the Orangerie.



2.01

2.01 Orangerie, Versailles
exterior parterre

2.02 Orangerie, Versailles
interior with palm trees

2.03 Orangerie parterre
with orange and pomegranate trees

2.04 Cent Marches Staircase
forms roof of orangerie interior



2.02

Much of the popular literature on Versailles has stressed the legendary side of its story. People are riveted by the descriptions of a palace whose main apartments were furnished with solid silver furniture and many of the great art works now in the Louvre. Tales – true stories at that – of how the colour scheme and scent of the garden outside the king's bedroom at the Grand Trianon could be changed from morning to evening by the moving of ten thousand flowerpots set into the ground still impress us.

Guy Walton
*Louis XIV's Versailles*⁹



2.03



2.04

THE ORANGERIE WAS CONSTRUCTED in the late 17th century during the reign of King Louis XIV. He had just established the royal court in Versailles, a move to consolidate his power by centralizing the government in a place separate from but close enough to Paris. He chose his father's former hunting lodge in the village of Versailles as the site for his new palace complex. Over the next century it grew into an eight-hundred acre stage for the aristocracy's political rituals. The palace and its gardens became a self-contained and ordered world unto itself, with its own subsidiary city to serve it. And not only did it reinforce the monarchy's divine right to rule, but representations of it, drawn up and dispersed by court artists, also did the same from afar.

The Orangerie was a single room in a palace of over two thousand, but its dignified utility is notable among acres of groomed topiary and statued fountains, and wings of mirrored walls and elegant furnishings. Terraced into the ground and modelled on the military architecture of the time, its sole purpose was to ensure the survival of delicate foreign plants during the cold French winter. It is said that its long vaulted hall once held over a thousand boxed orange trees, themselves a symbol of France's wealth and wide-ranging reach throughout the globe.

From November to April, this room, privy only to the gardeners, must have been a wonderful oasis from the odours pervading the gilded halls of the chateau; it wasn't until "shortly before Louis XIV died in 1715, [that] a new ordinance decreed that feces left in the corridors of Versailles would be removed once a week."¹⁰ In contrast, the tropical air of the orangerie, warmed by the south sun through arched windows, was perfumed by orange blossoms that, by some trick, bloomed all year.

Meanwhile, the rest of France lived its life never knowing the taste or the scent of sweet orange. In his novel, *Perfume: the Story of a Murderer*, Patrick Süskind gives this description of life in 18th century France:

In the period of which we speak, there reigned in the cities a stench barely conceivable to us modern men and women. The streets stank of manure, the courtyards of urine, the stairwells stank of moldering wood and rat droppings, the kitchens of spoiled cabbage and mutton fat; the unaired parlors stank of stale dust, the bedrooms of greasy sheets, damp featherbeds, and the pungently sweet aroma of chamber pots. The stench of sulfur rose from the chimneys, the stench of caustic lyes from the tanneries, and from the slaughterhouses came the stench of congealed blood. People stank of sweat and unwashed clothes; from their mouths came the stench of rotting teeth, from their bellies that of onions, and from their bodies, if they were no longer very young, came the stench of rancid cheese and sour milk and tumorous disease. The rivers stank, the marketplaces stank, the churches stank, it stank beneath the bridges and in the palaces. The peasant stank as did the priest, the apprentice did as his master's wife, the whole of aristocracy stank, stank like a rank lion, and the queen like an old goat, summer and winter. For in the eighteenth century there was nothing to hinder bacteria busy at decomposition, and so there was no human activity, either constructive or destructive, no manifestation of germinating or decaying life that was not accompanied by stench.

And of course the stench was foulest in Paris, for Paris was the largest city of France.¹¹

This squalor was the hastily forgotten backdrop to Versailles.

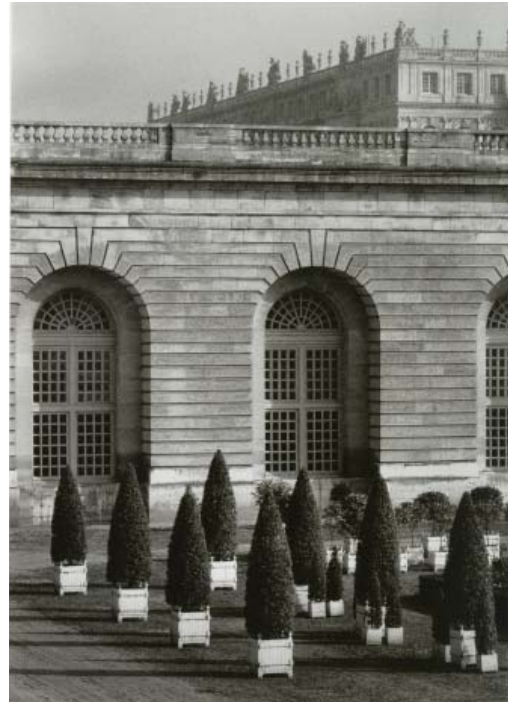

2.05

2.05 Facade of Orangerie

2.06 *Fireworks on the Canal (18 August 1674)*
engraving by Le Pautre, 1676

2.07 *Fireworks at Versailles*
engraving by Israel Silvestre

In both the idyllic and the grotesque renderings of court life at Versailles, the elements of appearance and performance were always in the spotlight. There is good reason for this. At Versailles in the late seventeenth century, to play, act, dance, or attend parties was no casual affair. These things were part of a politics of performance that celebrated the monarchy, signified submission to absolutism, kept the nobility under surveillance, and used the royal residences and their gardens as sites for public display of state power.

Chandra Mukerji
*Territorial Ambitions & the Gardens of Versailles*¹²

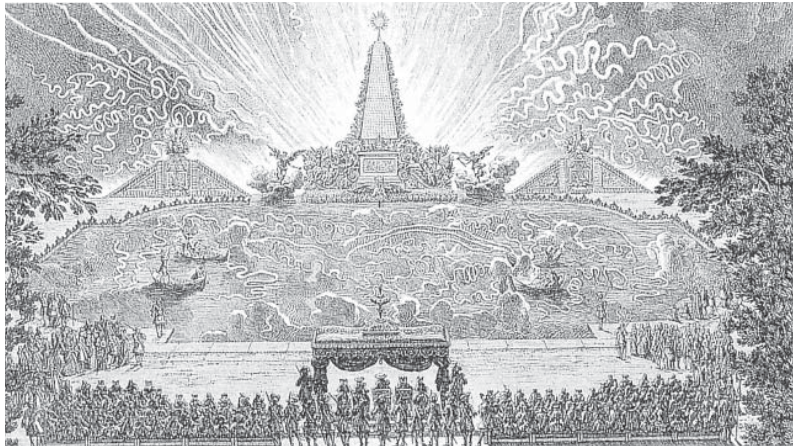

2.06

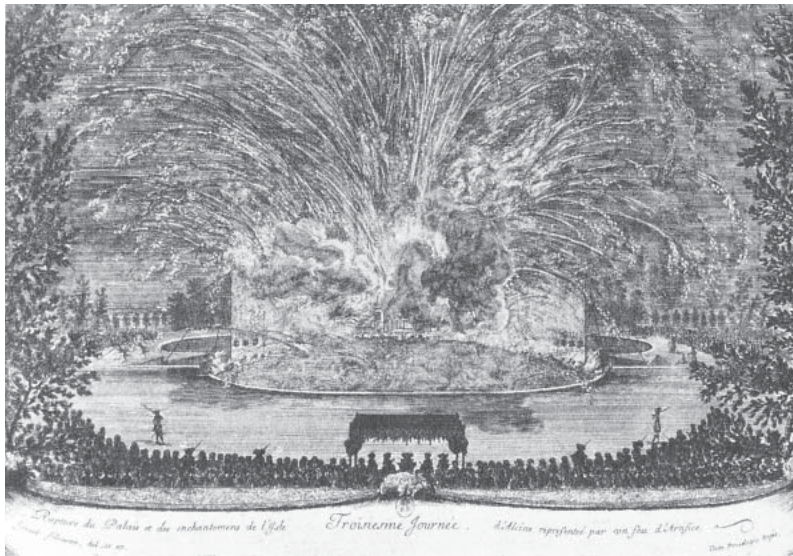

2.07



2.08

2.08 *Louis XIV* equestrian portrait
Charles Le Brun, 1668

2.09 Caricature of Louis XIV
cartoon by Thackery

2.10 *The King in Ballet Position*
Hyacinthe Rigaud, 1701

In spite of his mediocre stature, about five feet four inches, though his wig and high heels added another ten inches to his height, Louis XIV had succeeded in giving himself an aspect so majestic, so solemn, that his presence always seemed formidable.

Jacques Levrion
Daily Life at Versailles in the 17th and 18th Centuries,¹³

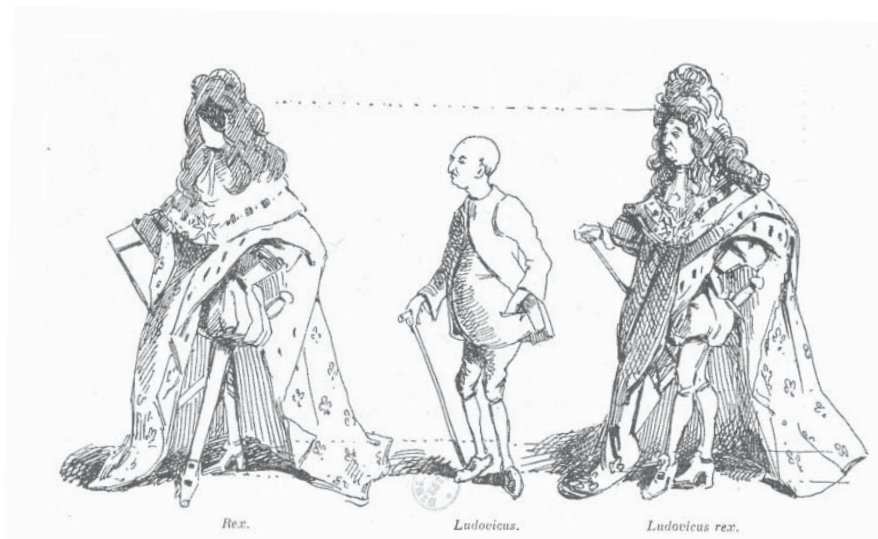

2.09



2.10



2.11

2.11 *Marie Antoinette*
film still, dir. Sofia Coppola, 2006

2.12 *View of Fountain of Dragons*
engraving by Pierre Aveline, 1686

2.13 *View of Orangerie and Chateau*
engraving by Pierre Aveline, 1686

Nobles did not verbally claim loyalty to the French crown in this period as much as they expressed it through their attendance at court, their adherence to French-led fashion, their use of finely tuned gestures and forms of etiquette blessed by the court, and their loyal participation in any festivities the king wished to see. Whether enjoying parties or watching the king's ritual awakening in the morning, aristocratic participation signified the authority of the king through physical gestures.

Chandra Mukerji
*Territorial Ambitions & the Gardens of Versailles*¹⁴

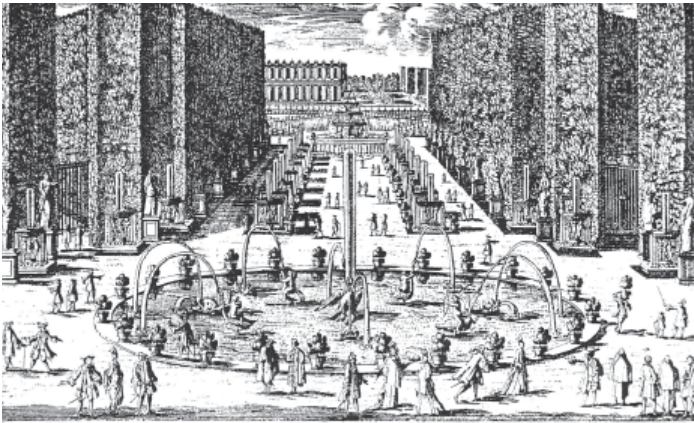

*Vue et perspective des Cascades et du Bassin du Dragon à Versailles
d'après l'original dans le Privilege du Roy*

2.12

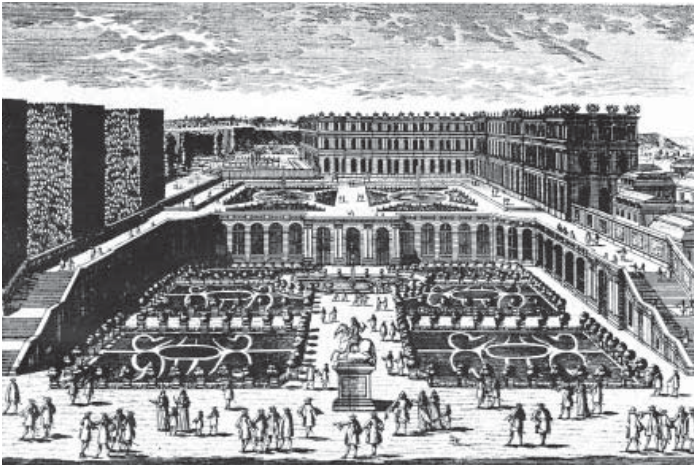

*Vue et perspective de l'Orangerie et du Château de Versailles du costé du Jardin 1682
d'après l'original dans le Privilege du Roy*

2.13



2.14

2.14 *Marie Antoinette*
film still, dir. Sofia Coppola, 2006

2.15 *Marie Antoinette*
film still, dir. Sofia Coppola, 2006

This scenario of power and desire was never better staged than in the Hall of Mirrors at Versailles. ... This gallery provided the ultimate specular baroque spectacle: each gesture is doubled, each movement is observable from all sides, each representation represented. And, seen in the infinitely reflective depths of the mirrors, across the expanses of the garden's length, is the reflected double of infinity at the vanishing point as the sun enters the gallery at sunset.

Allen S. Weiss
*Mirrors of Infinity*¹⁵



2.15

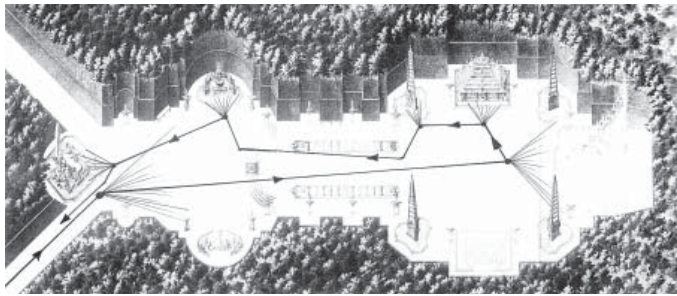

2.16

2.16 Diagram showing promenade in the *Arc de Triomphe bosquet*, Catherine Szanto

2.17 *The Gardens of Le Notre at Versailles* engraving, Jacques Rigaud, detail

2.18 *Plan of Versailles*

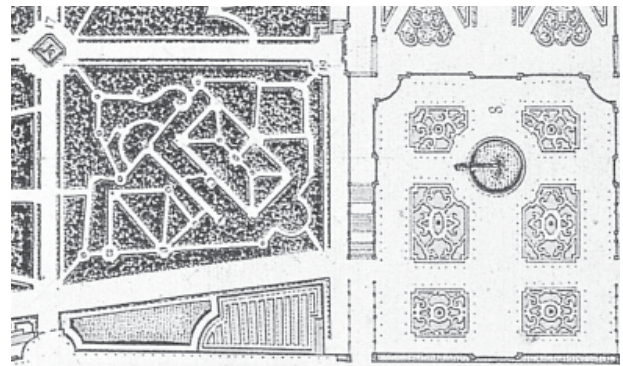

2.17

[The king's hand-written itineraries through his gardens, *Maniere de montre les Jardins de Versailles*] told visitors how to walk in a semi-circular pattern through the parterres and bosquets of the *petit parc*, and where to look as they moved. When they approached intersections of walkways they were told how to turn to appreciate a view or to see the artwork or chateau from a different angle; they had their attention focused on the garden's spatial design and the objects punctuating it. Thus they were taught to inventory the lands and wealth of the French king.

Chandra Mukerji
Territorial Ambitions & the Gardens of Versailles,¹⁶

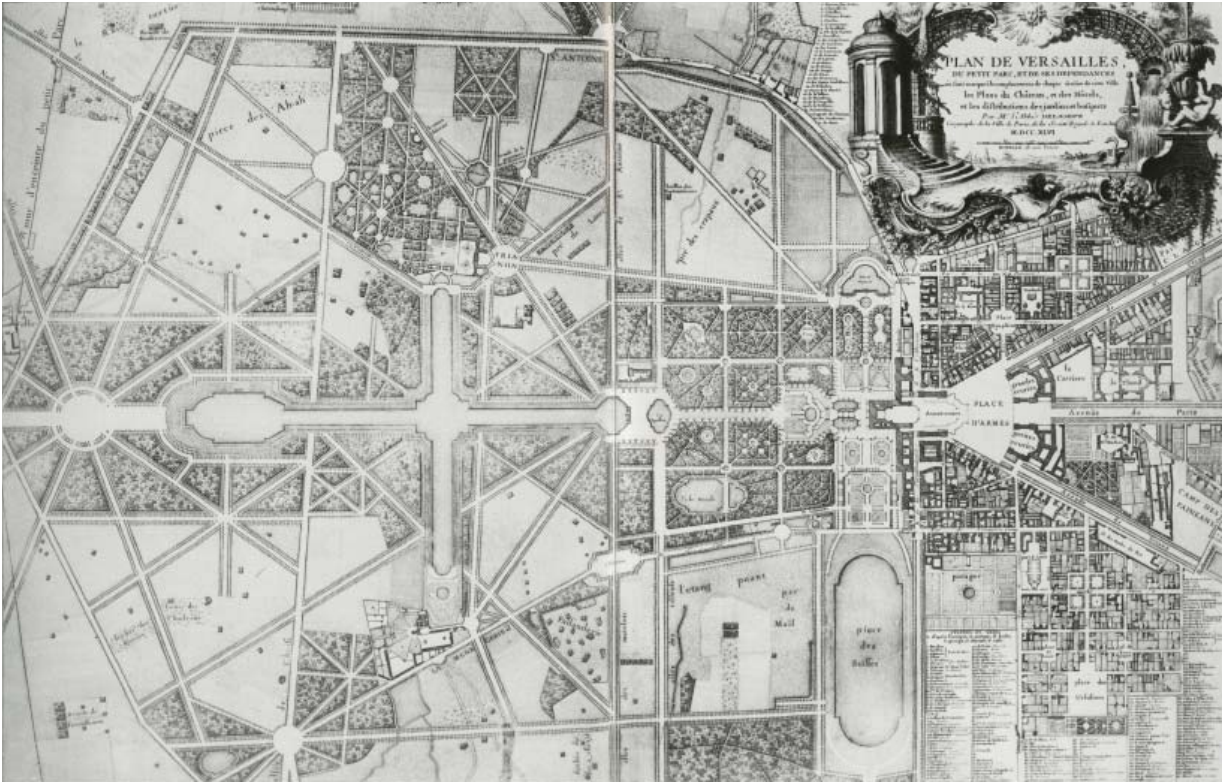

2.18



2.19

2.19 The chateau at sunset

2.20 *Marie Antoinette*
film still, dir. Sofia Coppola, 2006

At Versailles, the sun sets at the infinite horizon, its full splendor reflected off the canal. And, in turning to view the chateau at sunset, one is met again with the reflection of the sun's rays off the chateau's windows. Here, the window no longer serves as the Renaissance frame through which the world is to be viewed and represented; it now functions as a baroque mirror, to distort and multiply effects.

Allen S. Weiss
*Mirrors of Infinity*¹⁷



2.20

- 2.21 Plan of Labyrinthe de Versailles
Sebastien La Clerc, 1677
- 2.22 Orangerie parterre
orange trees being put out for spring
- 2.23 Interior of Orangerie

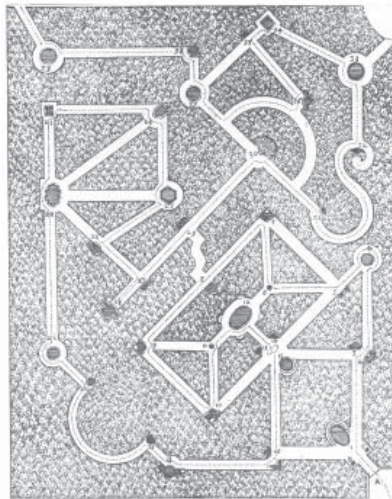

2.21

It all begins with gardens, the most trusting and innocent of human constructions. Yet, inspecting them, the *supposed* innocence of gardens, one is tempted to call it, for they are places where the undeclared war between architecture and its antitype, nature, between growth and the ordering impulse, is presented as a delicious harmony. They are places which flirt with allowing art to disappear, which seem to embrace principles hostile to form of any kind – irregularity, change, an urge to destroy. This is the hubris of gardens, to think that they could really improve on or collect the unruliness of natural forces and make a scene of it, like a play in which the actors were all wild animals.

Robert Harbison
*The Built, the Unbuilt, and the Unbuildable*¹⁸

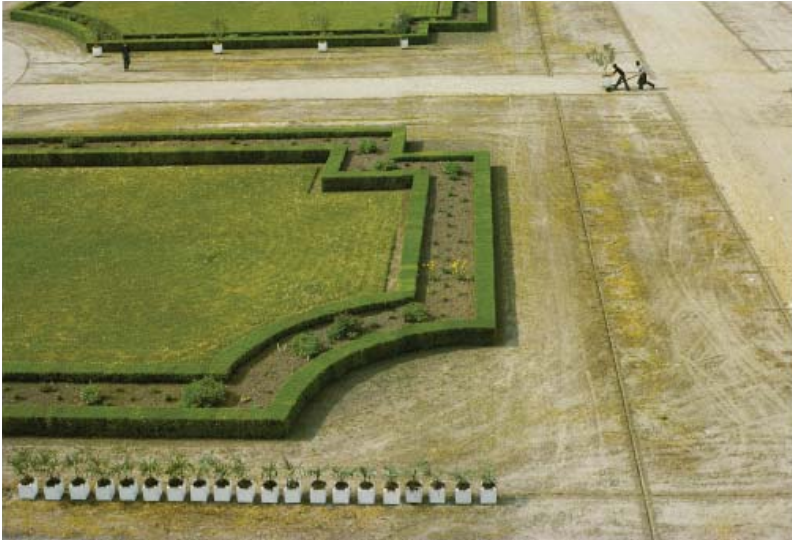

2.22

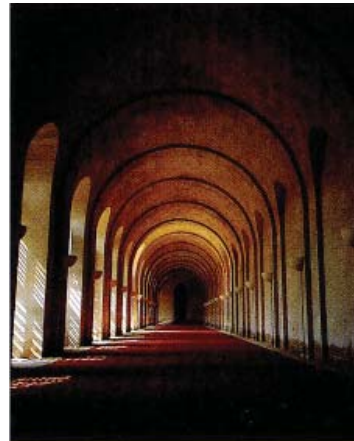

2.23

THE PYLON

Luna Park's Electric Tower, Coney Island, New York.

ONCE, DISASTER STRUCK Coney Island with startling consistency.

- 3.01 *The Fall of Pompeii*
Dreamland
- 3.02 *Fighting the Flames*
Dreamland
- 3.03 *Fire and Flames*
Luna Park



3.01

The amusement park and the historical reconstruction often promise to bring history to life, and it is here that we must pay particular attention once more to the relation between miniature and narrative. For the function of the miniature here is to bring historical events “to life,” to immediacy, and thereby to erase their history, to lose us within their presentness. The transcendence presented by the miniature is a spatial transcendence, a transcendence which erases the productive possibilities of understanding through time. Its locus is thereby the nostalgic. The miniature here erases not only labor but causality and effect.

Susan Stewart
*On Longing*¹⁹



3.03



3.02

EVERY HOUR A FIRE LIT WITH AN employee's match appeased the hungry crowds in Dreamland. Another perpetually raged at Hell Gate, while the flames in Lilliputia, the Midget City, were more intermittent. Only in the disaster fetish wonderland called Coney Island could you witness the devastation of San Francisco by earthquake, a volcanic eruption bury ancient Pompeii, a wild west buffalo stampede, and the storming of Peking, before ending the heart-racing night with a ride over a waterfall under a sky bright with fireworks.

These unnatural disasters drew visitors by the million every summer, May to September, from the turn of the century until the last of its brilliant heyday in the late 1940s. For fifty years people came, entered, and watched. They paid to see these constructed destructions, finding amusement in a kind of fatal attraction - to taste near death, near danger, near but not quite visceral experience. In his book, *Coney Island: The People's Playground*, Michael Immerso writes about Coney's twisted relationship with fire:

Fire was a regenerative element at Coney Island. By periodically burning itself down it was able to re-create itself in a new guise. Combustible in a literal as well as figurative sense, it was most potent at that point where the illusion of danger ignited into conflagration. The fire that decimated Dreamland began in an attraction called Hell Gate and released lions into the streets. During another of Coney's many fires, seventy thousand people gathered to watch, while just beyond the engulfed area the dancing and concert halls played on.²⁰

Coney Island had been a site of escape from the city and its strictures from its first stable connection, a bridge constructed in the early 19th century. One end of the island grew into a resort town that tastefully catered

to Manhattan's idle rich, while at the other, a loose refuge for boozing, gambling, prostitution, and corruption took root. Both flourished in relative isolation from the growing city until 1865, when the first railroad made it to the island. Now able to bring in average pleasure-seekers by the trainload, the island's centre quickly bloated with beachside amusements, attractions and distractions, all at affordable prices squarely aimed at the urban masses of New York – from the tenement dwellers, sweatshop workers, and immigrants to the growing middle class.

At its height, Coney's trifecta of amusement parks – Steeplechase, Luna Park, and Dreamland – filled the city's growing need to escape. Every weekend they swelled with people driven to consume every grotesque, obscure, foreign offering of the island: one-legged dancers, wax museums, minstrel shows, giants and dwarves, exotic beasts, mechanical horses, illusionists, Venitian canals, Swiss mountains, Middle Eastern bazaars replete with belly dancers and camels, even The End of the World next to the moon, all on a single strip of sand. Rem Koolhaas' *Delirious New York* delves into this architecture of subliminal desire and movement:

According to an intuitive cartography of the subconscious, Reynolds [Dreamland's creator] arranges 15 facilities around his lagoon in a Beaux-Arts horseshoe and connects them with a completely even supersurface that flows from one facility to the next without a single step, threshold or other articulation - an architectural approximation of the stream of consciousness.²¹

It was as if the travelling circus tired of its endless wandering from town to town and found its resting place by the sea. Here the castaways collected into the strangest seasonal exhibit in the world, at least for a time.



3.04

3.04 Coney Island beach, illustration from Harper's Weekly, 1867

3.05 Brooklyn and Manhattan

Coney Island is discovered one day before Manhattan – in 1609, by Hudson – a clitoral appendage at the mouth of New York's natural harbor, a 'strip of glistening sand, with the blue waves curling over its outer edge and the march creeks lazily lying at its back, tufted in summer by green sedge grass, frosted in winter by the pure white snow...'. The Canarsie Indians, the original inhabitants of the peninsula, have named it Nariioch - 'Place Without Shadows' - an early recognition that it is to be a stage for certain unnatural phenomena.

Rem Koolhaas
*Delirious New York*²²



3.05



3.06

3.06 Coney boardwalk, c. 1890

3.07 Midget City, Dreamland

3.08 Illusionist at work

Midgets, giants, fat ladies, and ape-men were both stigmatized and honored as freaks. They fascinated spectators in the way they displayed themselves openly as exceptions to the rules of the conventional world. Their grotesque presences heightened the visitors' sense that they had penetrated a marvelous realm of transformation, subject to laws all its own. The popular distorting mirrors furnished the illusion that the spectators themselves had become freaks. Thus Coney Island seemed charged with a magical power to transmute customary appearances into fluid new possibilities.

John Kasson
*Amusing the Million*²³



3.07



3.08



3.09

3.09 Topsy the Elephant, 1903

3.10 Elephant Colossus, hotel sections

3.11 The Cairo Pavilion

The most celebrated Luna elephant was the ill-fated Topsy, who was electrocuted at the park in 1903 after killing several of her trainers. The sad spectacle was recorded in an early film by Thomas Edison, who also conducted the electrocution.

Michael Immerso
*Coney Island: The People's Playground*²⁴

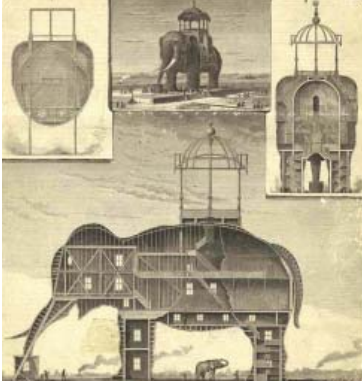

3.10

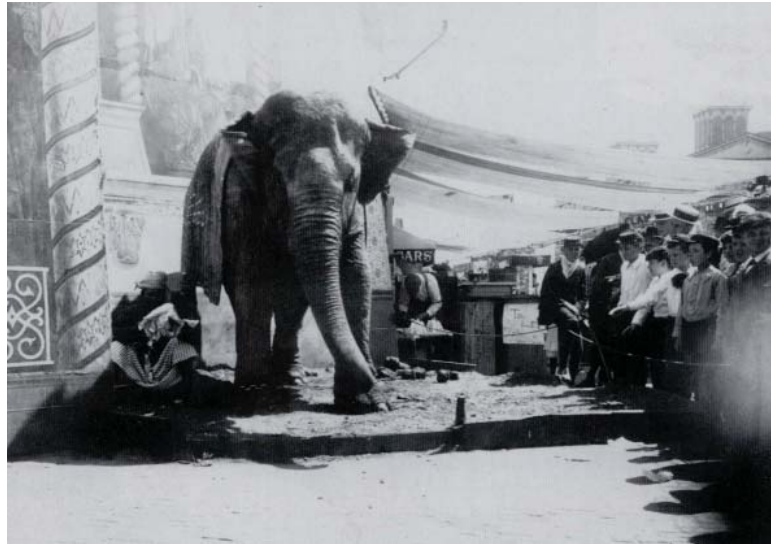

3.11



3.13



3.12

3.12 Coney Island beach
1930s

3.13 The boardwalk
circa 1929

3.14 *Coney Island Beach*
by Weegee, 1940

Coney Island appeared to have institutionalized the carnival spirit for a culture that lacked a carnival tradition, but Coney located its festivity not in time as a special moment on the calendar but in space as a special place on the map. By creating its own version of carnival, Coney Island tested and transformed accustomed social roles and values. It attracted people because of the way in which it mocked the established social order.

John Kasson
*Amusing the Million*²⁵



3.14



3.15

3.15 Promenading in Luna Park

3.16 *View of Luna Park at night, Coney Island, N. Y.*
postcard

3.17 *Luna Park at night*
postcard

Fred Thompson's Luna Park was arguably the greatest amusement park ever devised. An entirely original form of environmental sculpture for mass amusement, Luna Park was a dazzling Arcadia of minarets, trellises, spires, promenades, and swirling fountains of electric lights.

Michael Immerso
*Coney Island: The People's Playground*²⁶



3.16



3.17

3.18 *A Coney Island of the Mind*
Lawrence Ferlinghetti, 1958

3.19 The Electric Tower
Luna Park, c. 1905

3.20 *Entrance to Luna Park at night, Coney Island*
postcard, c. 1906

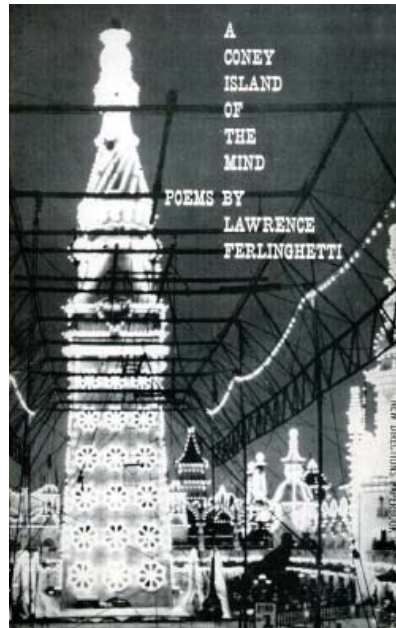

3.18

Thompson has designed and built the *appearance*, the exterior, of a magic city. But most of his needles are too narrow to have an interior, not hollow enough to accommodate function. ... Luna's astronauts may be stranded on another planet, in a magic city, but they discover in the skyscraper forest the over-familiar instruments of pleasure – the Bunny Hug, the Burros, the Circus, the German Village, the Fall of Port Arthur, the Gates of Hell, the Great Train Robbery, the Whirl-the-Whirl. ... Luna Park suffers from the self-defeating laws that govern entertainment: it can only skirt the surface of myth, only hint at the anxieties accumulated in the collective unconscious.

Rem Koolhaas
*Delirious New York*²⁷

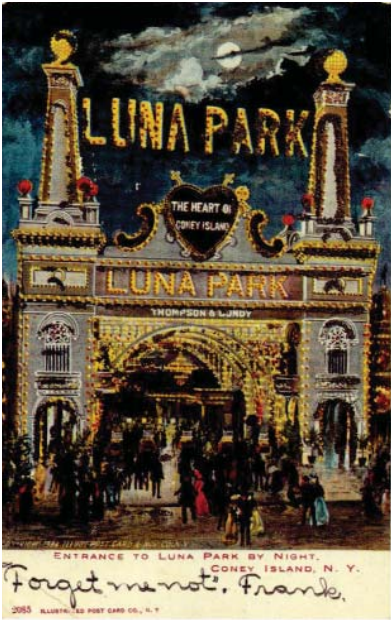

3.20



3.19

3.21 Cyclone , 1928

3.22 *Coney Island Beach*, c. 1994

3.23 Parachute ride, 1940s



3.21

Twenty million people visited during the summer season of 1909, as compared to the 5 million annually who were attracted to Disneyland when it opened in 1955. The era of the great amusement parks was, however, short-lived. In 1911, Dreamland burned to the ground in a spectacular fire that transformed its 375-foot-high beacon tower into a shaft of flame.

Michael Immerso
*Coney Island: The People's Playground*²⁸



3.22



3.23

THE FRAME

Bath at the Alhambra Palace, Granada, Spain.

AT THE ALHAMBRA, in the 14th century, leisurely afternoons were often passed picnicking in the cemetery-garden.



4.01

4.01 *Generalife garden*

4.02 *Tower of the Captive and Tower of the Infantas*
view from Generalife

And once you enter here, you are struck first by the smell, which awakens the recollections of a visit to the Alhambra. Here are two varieties of lavender flowers; citrus trees, bearing sour oranges, lemons and calamondin; jasmine vines in bloom, winding up pillars; crepe-myrtle, safflower, rosemary and valerian arrayed in geometric beds. And the scents, with their sweet spice, seem to invoke the mythic imagery of the place and its hold on the imagination.

Edward Rothstein
*Temptations found in Gardens of Islamic Delight*²⁹



4.02

UNDER THE SHADE OF TREES AND AMONGST fragrant flowers, visitors would pass the day in the company of friends and family in the *rawdā*, just outside the palace. *Rawda* translates into both garden and cemetery, and it is understood that the two are interchangeable, one and the same, inseparable in image and atmosphere. Rawdas, and the heavenly paradise they represented, were so revered by the Andalusian Moors that, in the 12th century, garden-poetry and flower-poetry were their own distinct genres of Arabic literature. Gardens were integral to buildings and the daily life that unfolded within them. Views constructed from one to the other were encountered around every corner. Special meals and events took place in these outdoor rooms, as described by Islamicist Robert Irwin:

In the Muslim world cemeteries, with cypresses, myrtles and other plants, were popular places for picnics and musical entertainments. Presumably the sense of transience afforded by such a site gave a pleasingly melancholy edge to the picnickers' enjoyment. The earthly funerary garden presented an image of the paradise to come. According to a saying of the Prophet, 'Between my tomb and my pulpit there is a garden [*rawdā*] which is one of the gardens of Paradise.'³⁰

This sensibility permeates the entire palace – the labyrinthine movement from one space to another, the rhythmic flow of water and light, the surfaces that dematerialize, the suggestion of multiple realities and worlds to be inhabited. From room to room, courtyard to belvedere, everything enhanced the perception of a truer paradise to come, an unfamiliar message to those of us who gaze upon its ruins. And so the story of this place, the only Muslim palace to survive from the Middle Ages, is one of ambiguity, one of time passed and lost and of fragments that remain, some perverted, some illusory; so much so that Irwin begins his book, *The Alhambra*, with this caveat:

As we shall see, there is uncertainty and dispute about every single feature of the Alhambra – its architecture, chronology, iconography, nomenclature and the way it was originally occupied. We are dealing not so much with a body of knowledge as with a body of wild guesses.³¹

When trying to decipher its architecture, the clouded nature of its past adds to its mystery from the original purposeful design and construction to the numerous erasures, additions, and renovations in the centuries since.

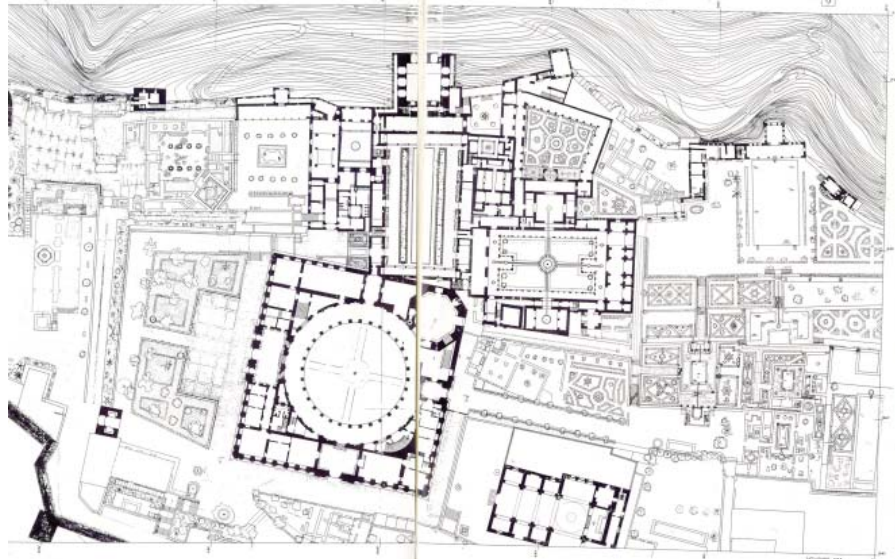

4.03

4.03 Partial plan of Alhambra

4.04 Tower of the Infantas, interior

4.05 Plan of Alhambra, c. 1840

The Alhambra itself was a city of palaces at its peak – within its red walls were six palaces with an attendant town to service them. What began as a fortified citadel on a spur of the Sierra Nevada in the 9th century became, by 1238, a proper town with a perimeter wall enclosing 14 hectares of land and aqueducts to water the growing town. Gardens, meadows, orchards and vineyards grew on all sides, always within view.

4.06 *Cuarto Dorado*
south facade

4.07 *Cuarto Dorado*
north facade with portico to Darro Valley

Parts [are] separated from each other in such a way that the passage from one to the other is never obvious. There are no portals or vistas leading from one unit to the other. The Cuarto Dorado is a gate, but it is also a trap, for it does not indicate the correct direction to take. In fact, the whole palace is like the City of Brass of *The Thousand and One Nights*, where secret passageways and small doors lead the visitor, accidentally and secretly, from one marvellous architectural setting to the next.

Oleg Grabar
The Alhambra ³²

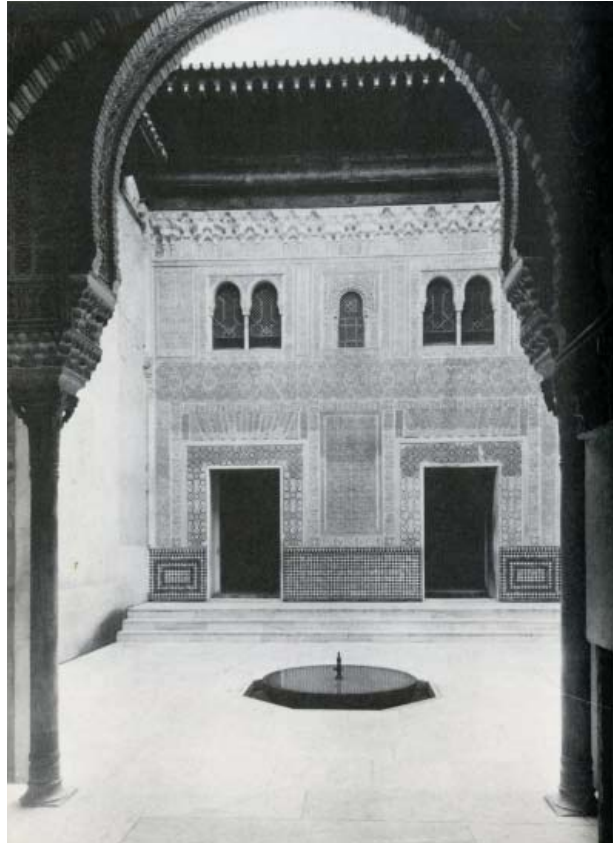

4.06



4.07

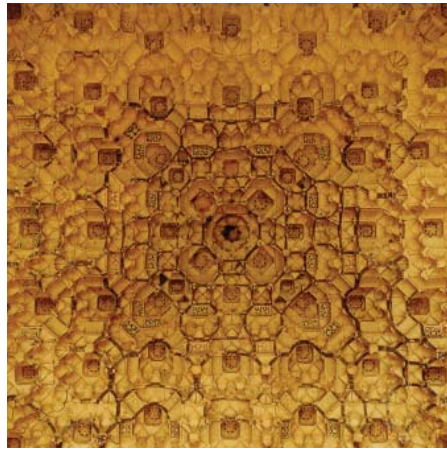

4.08

4.08 *Muqarna ceiling*
The Court of Lions

4.09 *The Court of Lions*
sections, NS + EW

The overwhelming objective of the Alhambra's elevation lies in its seeking to provide what may be called illusions, that is, impressions and effects which are different from the architectural or decorative means used to create them. From the very rough contrast between its external and internal profiles all the way to the analysis of a single bay in the Court of Lions or the muquarnas, we may discover a consistent attempt to give the impression that things are not quite what they seem to be.

Oleg Grabar
The Alhambra ³³

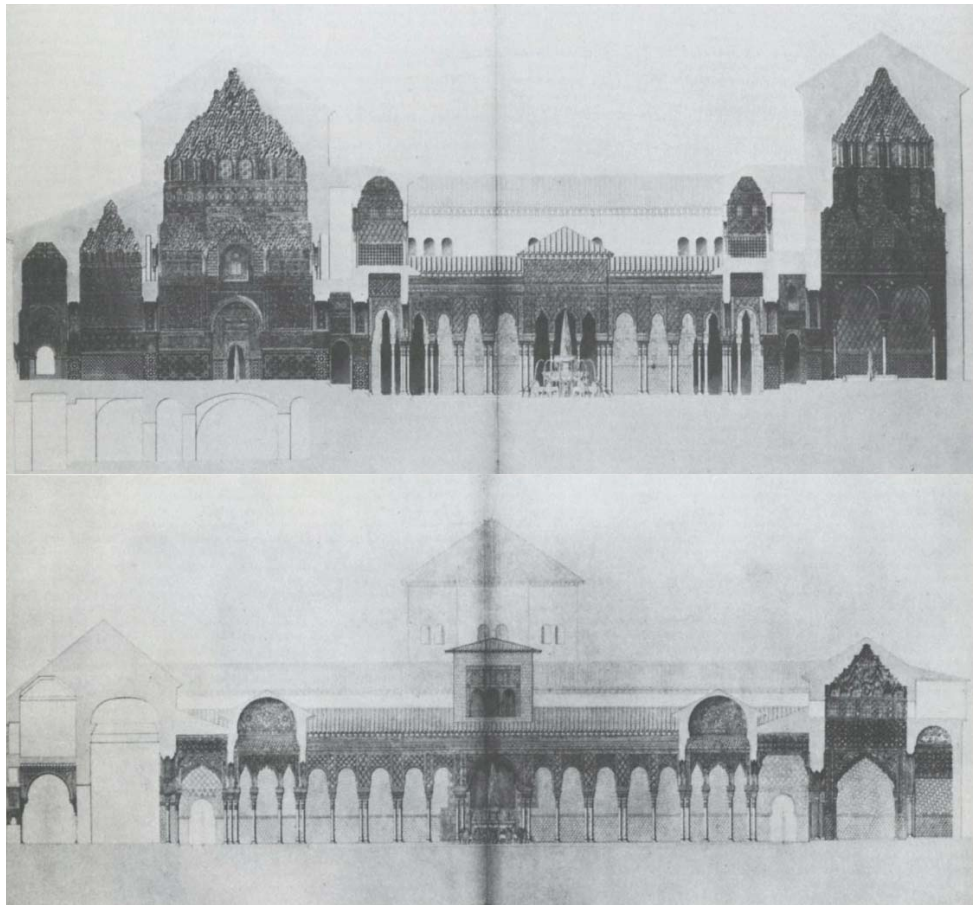

4.09



4.11



4.10 *Court of Lions*
view from arcade

4.10

4.11 *Arcade*
south side of Court of Lions

4.12 *Bath*
steamy dome

4.13 *Detail of wall decoration in alcove*
Hall of Ambassadors

The sensuousness of the forms, whereby walls, columns, ceilings, water, at times space itself are not fixed constants and definite compositions but become almost alive with sinuous lines and profiles, with moving surfaces or ornament, and are endlessly affected by a changing and contrasting light.

Oleg Grabar
The Alhambra ³⁴

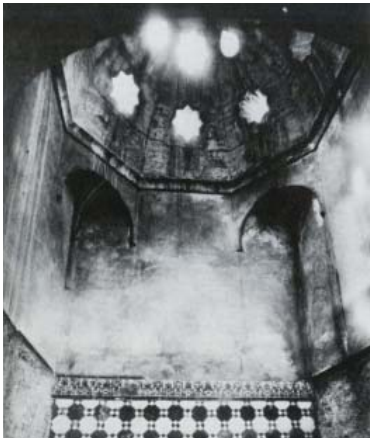

4.12



4.13



4.14

4.14 *Court of Lions*
looking north

4.15 *Court of Lions*
looking west

The garden would have been a sunken one, so that the carpet of flowers did not impede the view of the fountain. Four raised walkways of stone would have then converged on the fountain. An account of the Court of the Lions in 1602 indicates that each quadrant of the courtyard contained six orange trees, growing amid flowers. It has further been argued that the shape of the garden, a rectangle divided by four water channels, was based on the *chahar-bagh*, the traditional 'fourfold plot' Persian garden design. From this point of view, it is possible to imagine that the buildings were hardly more than a frame for the luxuriant garden.

Robert Irwin
The Alhambra ³⁵

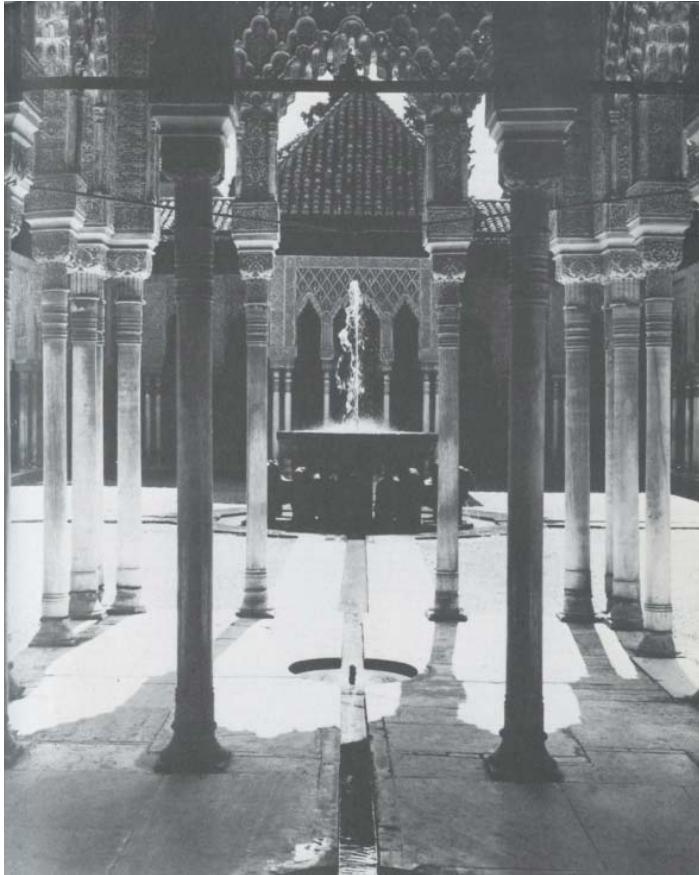

4.15

4.16 *Decorative tiling*
Hall of Ambassadors

4.17 *Bath, ceiling of the main hall*
Sala de las Camas

4.18 *Niche for water jar*
Hall of Two Sisters

This kind of aesthetic objective, which seeks to emphasize a frame and to endow it with physical beauty in such a way that the quality but not the nature of what happens within the frame is affected, was deep imbedded in at least one side of medieval Islamic tradition – that of the great carpets and gardens of Safavid Iran or the ceramics and metalwork of earlier times.

Oleg Grabar
The Alhambra ³⁶



4.16

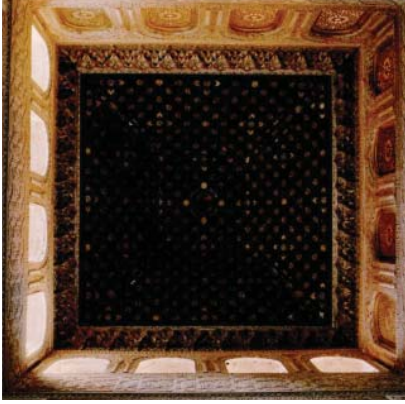

4.17

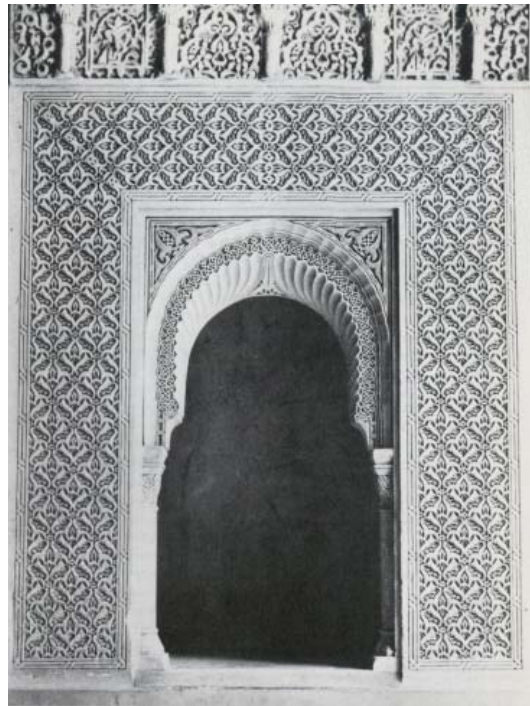

4.18

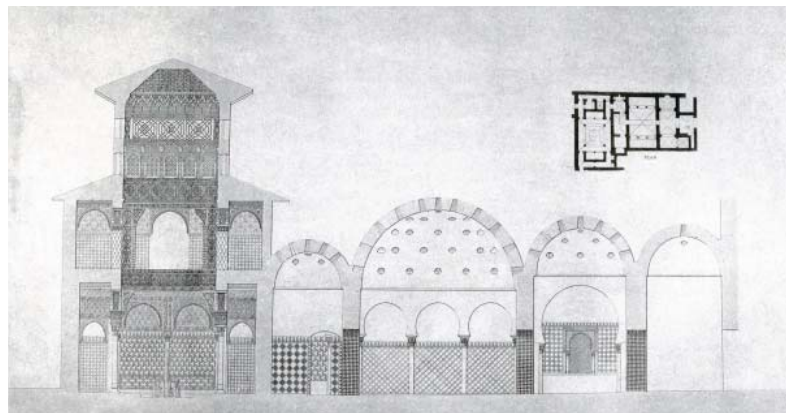

4.19

4.19 *Bath, section with small plan*
Goury-Jones, c. 1840

4.20 *Court of Myrtles, looking north*
to portico and Tower of Comares

4.21 *Bath, main hall*
Sala de las Camas

Practically invisible and insignificant from the courts, these windows can be used to look into the courts from the bath. Private though its activities may be, the bath becomes a place from which the official or semi-official business of the palace can be witnessed.

Oleg Grabar
The Alhambra ³⁷



4.21



4.20

THE ROOM

Turbine Hall, Tate Modern, London.

THE ESSENCE OF ROTTERDAM was distilled from a dubious mixture that included Rhine water, dog, hashish, cinnamon, patchouli, algae, and tangerine.



5.01

- 5.01 St. Paul's Cathedral from
Bankside Power Station site, 1947
- 5.02 Giles Gilbert Scott's final design
Model of power station and site
- 5.03 Bankside Power Station

In another city, by another river, a power station faces St. Paul's Cathedral from across the Thames. Though the building was specifically designed to be a counterpoint to St. Paul's by respected British architect Giles Gilbert Scott, there was strong opposition to its location directly opposite the Cathedral, symbol of the Church of England and seat of the Bishop of London. Nevertheless, the Bankside Power Station celebrated its official opening in 1963.



5.03



5.02

IN 2005, TO COINCIDE WITH AN EXHIBITION of their work (*Beauty and Waste in the Architecture of Herzog & de Meuron*) at the Netherlands Architecture Institute in Rotterdam, Jacques Herzog and Pierre de Meuron created a perfume. The scent, named *Rotterdam*, was meant to conjure the Dutch city - to encapsulate the feeling of walking its streets, purely by olfaction. In an extended interview with Philip Ursprung, Herzog explains:

The really interesting thing about perfumes is not actually the scent itself, but rather the memory that is stored with the scent. Smells and scents can evoke experiences and images of the past, almost like photographs. For us certain smells always produced architectural images and spatial memories - almost like an inner film. So we were never interested in producing a specific scent; we wanted rather a library of smells and scents that one might access like a kind of interface between fiction and reality: perfumes that smell like sweat, like oil paint, like wet concrete or warm asphalt on which it has rained, or like an old kitchen. ...

And another thing about scents that come and go: there is an aspect of this that applies to architecture as well, namely that it leaves a mark on us and reminds us of our own history. ... Memories and experiences are always individual. This element of the elusive emotions that define the aura of a place plays a role in our perception of architecture. Architecture cannot be neutral and is, in a sense, a very old-fashioned medium inasmuch as it completely involves us physically and refuses to let us be detached about it.³⁸

The limited run of one thousand 15 mL bottles was sold, among other places, at the Tate Modern in London, where the architects had just renovated a power station into a museum of modern art. In the design of both, Herzog & de Meuron show that in the consideration of places in particular and space in general, the invisible and the atmospheric should not be ignored in favour of easier images. Favourably reviewed by perfume and architecture fans alike, *Rotterdam* is now gone, impossible to find save perhaps for the remains of a bottle here or there, hidden away in scattered stashes around the world.



5.04

5.04 Turbine Hall, 1994
· before removal of plant

5.05 · after removal of plant
· removal of flooring
· supports for ramp
· construction of ramp

The Bankside power station was the first large generating station to be fired by oil rather than coal. Construction began in 1948, and would continue in phases for another 15 years before its full completion. Then, on October 31, 1981, it was shut down due to the increased cost of oil which made coal and nuclear power generation more economical. So there it lay by the river, dormant and untouched, for another 14 years until 1995, when it was taken apart from the inside out for its transformation into the Tate Modern.





5.05

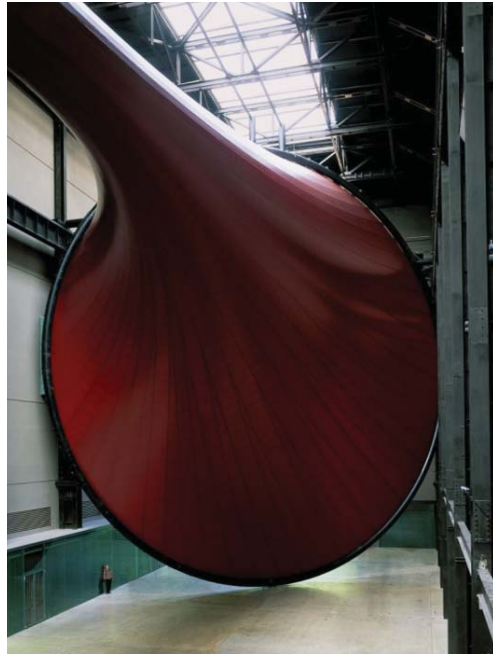

5.06

5.06 *Maryyas*
Anish Kapoor, 2002

5.07 *Shibboleth*
Doris Salcedo, 2007

One of the things about a museum is that it is a public space but it is also a place in which people create their own personal space. One of the interesting experiences for a visitor to Tate Modern is going to be the combination of that sense of sharing experience as you move through the building, but also having your own intimate and individual relationship with a work of art or with a part of the building. I think you need that absence in certain parts of the building in order to give room for the mind to move.

Nicholas Serota
in conversation with Rowan Moore
Building Tate Modern ³⁹



5.07



5.08

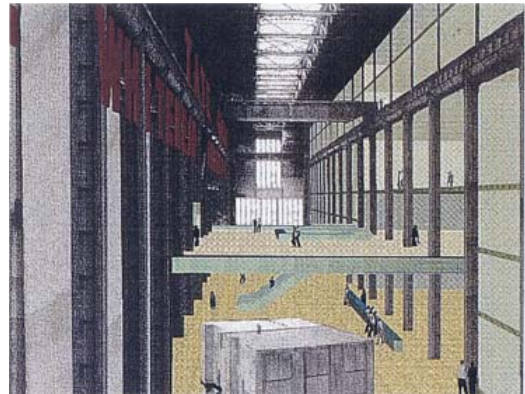

5.09

5.08 *House*, 1993-1994 (East London)
Rachel Whiteread

5.09 Turbine Hall, competition entry
Herzog & De Meuron, 1994

5.10 *Embankment*
Rachel Whiteread, 2005

5.11 *Test Site*
Carston Holler, 2006



5.10

The Turbine Hall is an extraordinary place, a very difficult place to work with. ... I wanted to make something that was like a landscape and sort of awe inspiring. And I was especially thinking about children and how they would respond to that — they have a freedom in the Turbine Hall that you don't get in any other museum situation. I wanted to make something that was profound, like being in a landscape, or being in a cathedral, something that had some elemental force to it.

Rachel Whiteread
*A Talk with: Rachel Whiteread*⁴⁰

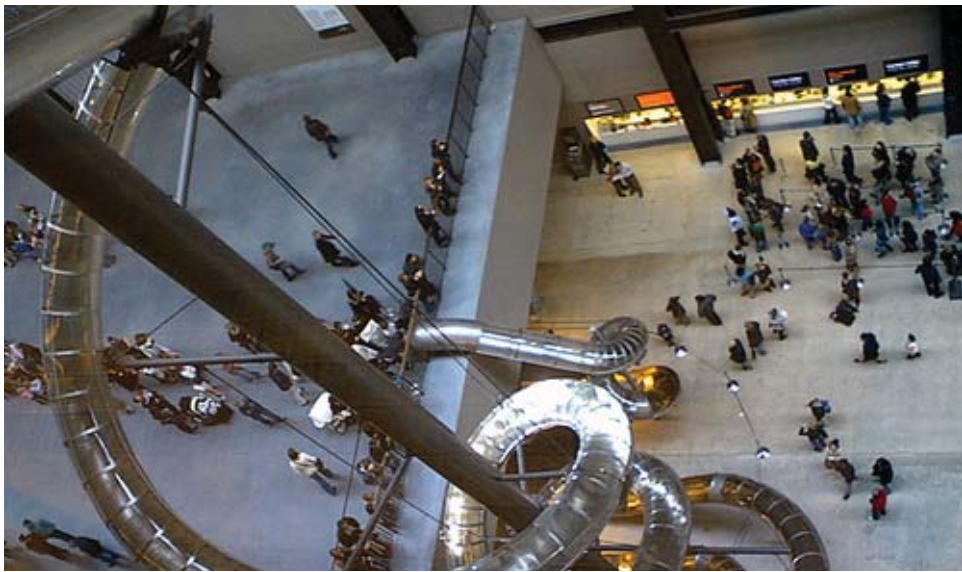

5.11



5.12

5.12 *The Weather Project*, from the floor
Olafur Eliasson, 2003

5.13 *The Weather Project*, from the bridge
Olafur Eliasson, 2003

The weather, in all its shades, is really about tactility. It is, in an odd way, about mental tactility – trying to imagine something – but also about “Oh, I got wet” or “I’m cold” or “I’m sweating.” It has these really physical aspects, but it’s also physical on an intellectual level. When you think about the cosmological potential of weather, it becomes almost physical. And yet, the weather also holds unbelievably profound questions: what is time? What is unpredictability? What is chaos? What is the turbulence of our atmosphere and universe?

Olafur Eliasson
in conversation with Hans-Ulrich Obrist
*Olafur Eliasson*⁴¹



5.13

5.14 *Dome Room*, rendered perspective
Sir John Soane Museum, London

5.15 *The Picture-Room*, panels closed & open
Sir John Soane Museum, London

Reduced in scale, inward-looking and cocooned within themselves, [they] seem to contain infinity, to reach to the very limits of the visible. Thus we may marvel before ninety-six goblets that fit precisely one into the next, or attempt to count the hundred heads engraved on a cherry stone, or the twenty-four minuscule spoons concealed within another cherry stone. Each tinier than the last and contained within it, these virtuoso exercises in the art of miniaturization are another demonstration of the general rule of containment and encapsulation, of treasures nestling one within the other, that was the governing principle of cabinets of curiosities.

Patrick Mauries
*Cabinets of Curiosities*⁴²



5.14



5.15

- 5.16 *Untitled (Hôtel de la Duchesse-Anne)*
Joseph Cornell, 1957

- 5.17 Sculpture gallery
Tate Modern

- 5.18 *Ballet of the Woodpeckers* in Tate Modern
Rebecca Horn, 1986

The cabinet of curiosities finds its *raison d'être* in a multiplicity of frames, niches, boxes, drawers and cases, in appropriating to itself the chaos of the world and imposing upon it systems – however arbitrary – of symmetries and hierarchies. It is like a shadow cast by the ‘unknown’, an unknown that dissolves into a shower of objects. It offers an inexhaustible supply of fragments and relics painstakingly slotted and fitted into the elected space, heavy with meaning, of a secret room.

Patrick Mauries
*Cabinets of Curiosities*⁴³



5.16



5.17



5.18



5.19

5.19 Turbine Hall
view from bridge

5.20 Tate Modern
nearing end of construction

Herzog & de Meuron's approach to Tate Modern embodies an understanding of human experience that is contradictory, uncertain, strange and many-shaded. It includes the knowledge that things are not always what they seem, the possibility or rather certainty of imperfection, the co-existence of shadows and light, the intertwined relationship of hope and pessimism.

Rowan Moore
*Building Tate Modern*⁴⁴



5.20

THE PASSAGE

The Great Pyramid of Khufu, Giza, Egypt.

AS KHUFU ASCENDED the throne of Egypt, he buried his father and began preparations for his own highly anticipated death.

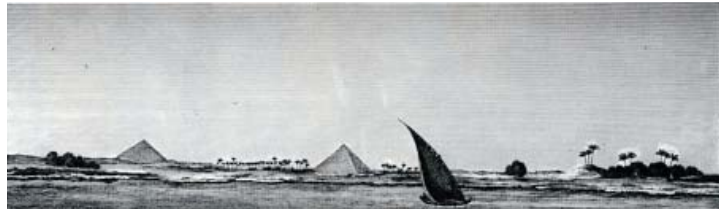

6.01

- 6.01 *The pyramids of Saqqara seen from the Nile*
Napoleonic Edition
- 6.02 *View of the Great Pyramid at sun rise*
Napoleonic Edition
- 6.03 *View of the Second Pyramid from the east*
Napoleonic Edition

Articles lost. What makes the very first glimpse of a village, a town, in the landscape so incomparable and irretrievable is the rigorous connection between foreground and distance. Habit has not yet done its work. As soon as we begin to find our bearings, the landscape vanishes at a stroke like the facade of a house as we enter it. It has not yet gained preponderance through a constant exploration that has become habit. Once we begin to find our way about, that earliest picture can never be restored.

Walter Benjamin
One-Way Street ⁴⁵

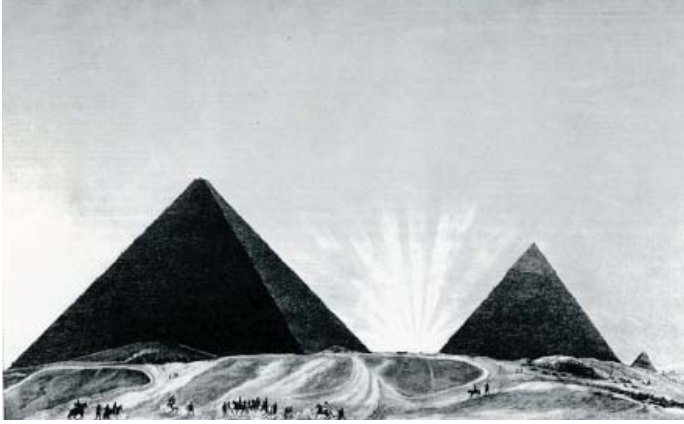

6.02



6.03

FROM GIZA, KHUFU COULD SEE THE NILE and its fertile floodplain to the east, while to the south, the pyramids of his ancestors lay in the distance. This desert plateau is where he, son of Sneferu and father of Khafre, chose to build his eternal home, his pyramid. In his book *Mountains of the Pharaohs*, archaeologist Zahi Hawass explains Khufu's choice in site:

It lay in the western desert, already the traditional location for a royal tomb, with its links to the setting sun. The geology of the plateau was ideal for pyramid building, for it included an outcropping of a limestone formation.⁴⁶

The building of his tomb was the most important undertaking of his reign as king, not only for his personal glory but also for the future of his people, and for the world as they knew and understood it. He began almost immediately, and as if overnight, a city grew between the desert and the river, its existence solely dedicated to the construction of his tomb.

During this time in Egypt, a pharaoh was considered the earthly manifestation of *Re*, ruler of the gods and embodiment of the sun. Upon his death, he would, through proper death ritual and burial in a pyramid, rise transformed to his divine station in the sky, from which he could keep the world in order and hold chaos at bay.

Today, well over four thousand years after the peak of pyramid-building, undiscovered pyramids are still being sought, found, and unearthed in Egypt. The meaning and function of their form continue to be the subject of much fascinated research despite the impossibility of ever arriving at a definitive answer. In *Building the Great Pyramid*, the authors discuss its possible origins:

One modern theory suggests that the pyramid derived its shape from observations of the sun's rays as they cut down in a triangular wedge through gaps in cloud formations. This seems plausible: from the time of Sneferu's rule, the solar deity became more and more important to Egyptian religion, and the pyramid texts state that the sun's rays can be used as ramps by means of which the king can ascend to heaven. According to this reading, the pyramid was regarded as the immaterial made material: light into stone.⁴⁷

Hawass' theory describes a more organic derivation of the pyramid form, with its roots in the cyclical changes of the seasons year to year:

The regularity of the agricultural cycle – the dryness of summer, the inundation followed by the reemergence and renewed fertility of the earth – so impressed the Egyptians that most of the different creation myths that have come down to us incorporate the image of a primeval mound arising out of the waters of chaos that existed before time, a mythological echo of the islands of earth that appeared each year at the recession of the flood.⁴⁸

The pyramid functions in a number of dimensions. It seems that, for these Egyptians, the physical and metaphysical aspects of life and death were intertwined, inseparable. Every action, every object, literal or figurative, miniature or gigantic - they all were capable of affecting the order of the universe, and of life itself. This can be seen in the Egyptian death ritual, particularly as it relates to royalty, as detailed by J.P Lepre in his guide to the pyramids, *The Egyptian Pyramids: A Comprehensive, Illustrated Reference*.

The liturgy manifested at this time emphasizes that the monarch is not of human parentage, has escaped death and shall be transformed to everlasting life, departing in the West and shining anew in the East, thus becoming an imperishable star. Later, during the course of this lengthy ceremony, mention is made of the pharaoh's senses being restored, with the opening of his eyes, ears, nose, and mouth, and his body members being symbolically reassembled. These incantations and physical acts were believed to constitute the crux of the embalming process.⁴⁹

After seventy days in preparation, the body would have crossed the Nile from east to west, toward the pyramid and the setting sun. Once inside the complex, the coffin would have been carried up to the pyramid's tiny entrance, down the descending passage, up the ascending passage and into the Grand Gallery, the final climb to the heart of the mountain: the King's Chamber. In this granite room his preserved body would be sealed inside a granite sarcophagus placed precisely on the central axis of the pyramid. From there, his spirit could transform as it travelled through to the surface, towards the sky.

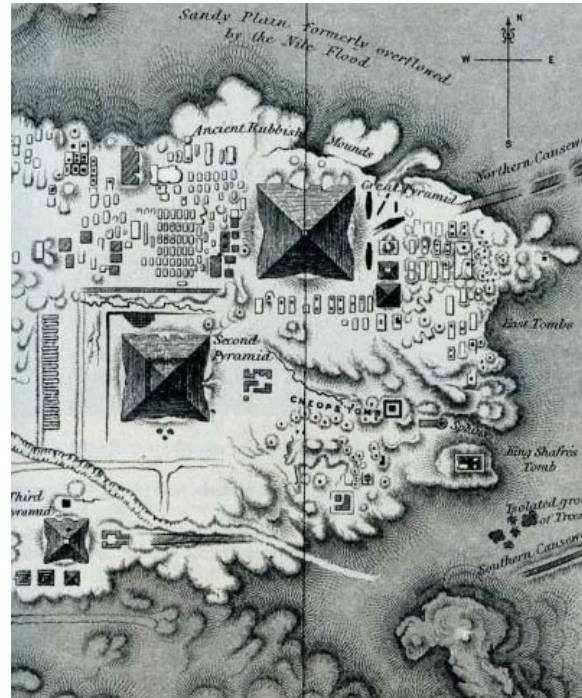

6.04

6.04 *Plan of Giza Complex*

6.05 *General plan of Memphis and surroundings*
Napoleonic Edition

Peret or 'emergence' was a period roughly corresponding to our winter, running from mid-November to mid-March, when the flood waters drained from the fields and farmers could begin to work on their land again. Shemu or 'dryness' lasted from mid-March to mid-July. The Nile sank to its lowest level, the fields drained completely dry and the soil began to crack and turn to dust. ... Akhet or 'inundation' ran from mid-July to mid-November. At this, the hottest time of the year, rain fell on the high ground and the Nile overflowed with life-giving water.

Kevin Jackson
*Building the Great Pyramid*⁵⁰

- 6.06 *Inside the Grand Gallery, upper tier and lower tier*
Napoleonic Edition
- 6.07 *Sections of Grand Gallery, including King's Chamber and Antechamber*
Napoleonic Edition
- 6.08 *Section of Great Pyramid, before discovery of air shafts and subterranean chamber*
Napoleonic Edition

The Great Pyramid was called Khufu's *Akhet* – his “horizon” – but the similarity of the word *akh* is more than a coincidence, for most of the pyramid names that have come down to modern times allude to the place where transformation from mortal remains to immortal being took place. So though we are fully justified in saying that a pyramid is a king's tomb, we must recognize that for Egyptians a royal tomb was much more than a place where remains were kept. It was the king's gateway to the stars – a launch-pad to the afterlife.

Kevin Jackson
*Building the Great Pyramid*⁵¹



6.06

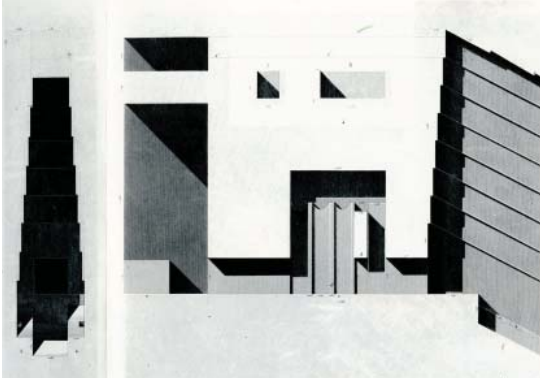

6.07

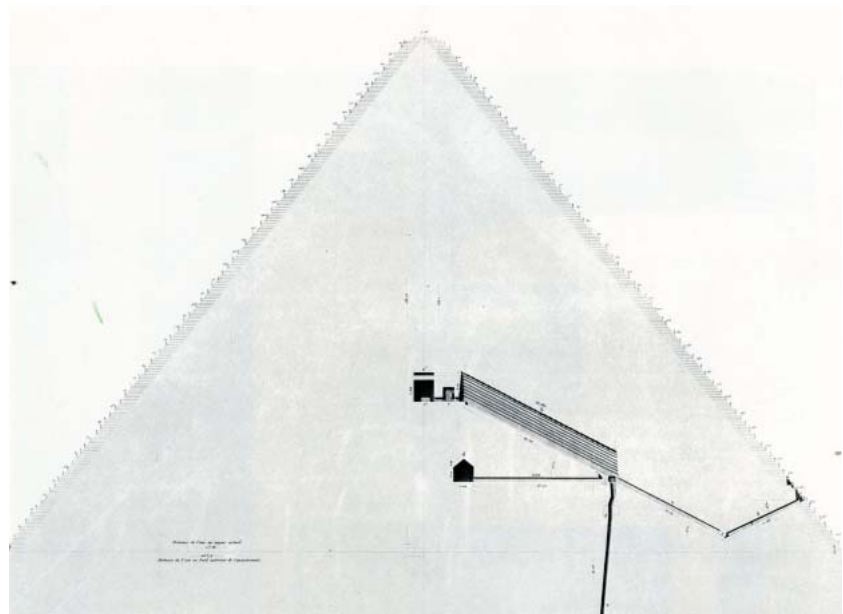

6.08

6.09 *Diagram of Great Pyramid*
relationship of air shafts to constellations

6.10 *Diagram of Great Pyramid*
major passageways and chambers

6.11 *The King's Chamber*

[Khufu's pyramid] is the only pyramid to contain "air shafts," mysterious tunnels, each about twenty centimeters square (three square inches), that lead outward from the north and south walls of the two upper chambers of his pyramid. ... One of the two air shafts in the King's Chamber is located on the central axis of the southern face of the pyramid and is at right angles to the east-west axis of the two boats. It may be that the soul of the king was to be able to magically travel through this air shaft in order to board his boat. The shaft also points toward Orion, identified by the Egyptians with the god Osiris. The northern shaft is directed toward the circumpolar stars and most likely represents a magical path on which the soul of the king would have traveled to join these stars, his fellow gods.

Zahi Hawass
*Mountains of the Pharaohs*⁵²

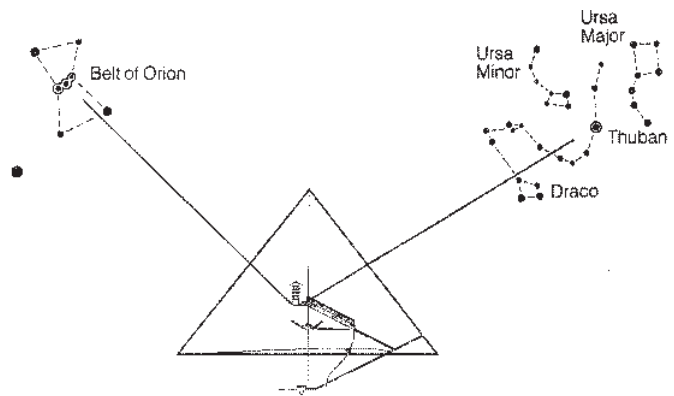

The Great Pyramid of Giza in cross-section
Alignments of shafts to stars c.2600bc as discovered by A. Badawy and V. Trimble in 1964

6.09

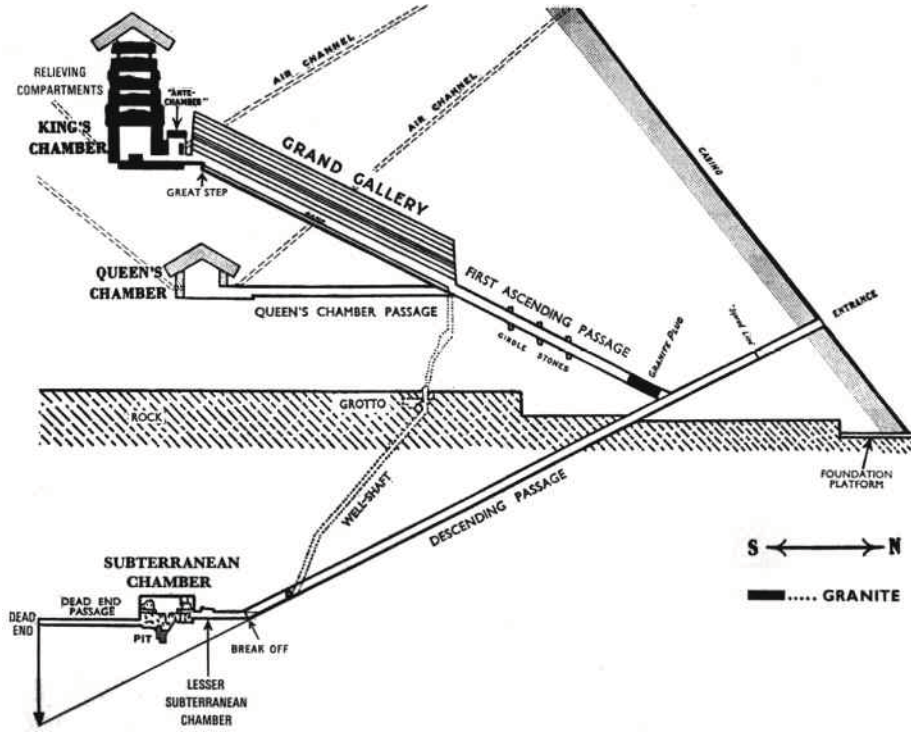

6.10

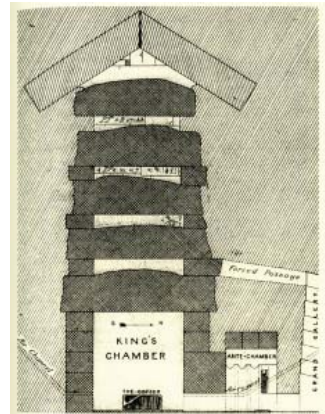

6.11

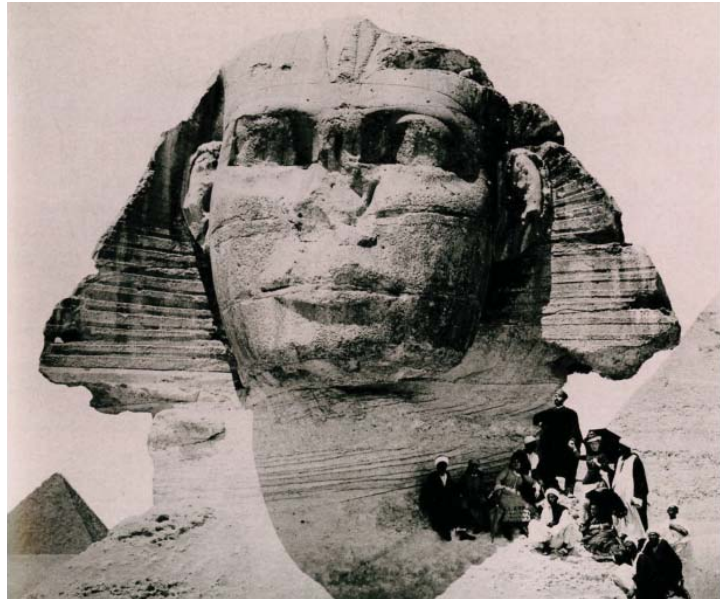

6.12

6.12 *Tourists on the Giza Sphinx*, 1890

6.13 *Entrance of Great Pyramid*

6.14 *Arab guides helping tourists on the Great Pyramid*
1850

Our most fundamental relation to the gigantic is articulated in our relation to landscape, our immediate and lived relation to nature as it “surrounds” us. Our position here is the antithesis of our position in relation to the miniature; we are enveloped by the gigantic, surrounded by it, enclosed within its shadow. Whereas we know the miniature as a spatial whole or as temporal parts, we know the gigantic only partially. We move through the landscape; it does not move through us. This relation to the landscape is expressed most often through an abstract of the body upon the natural world. Consequently, both the miniature and the gigantic may be described through metaphors of containment – the miniature as contained, the gigantic as container.

Susan Stewart
On Longing ⁵³



6.13

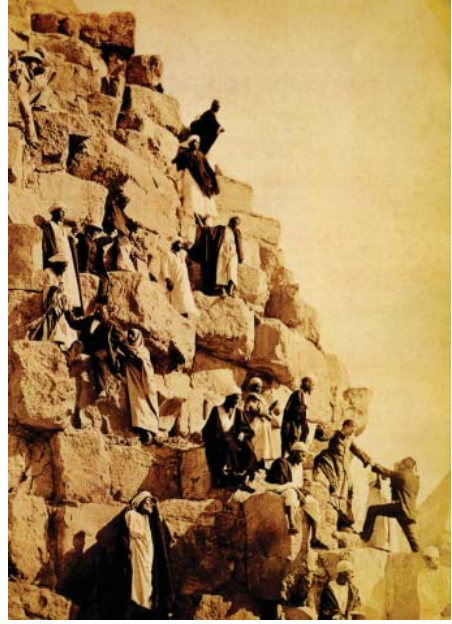

6.14

6.15 *'Rodan Crater'*,
Video still, Erin Shirreff

6.16 *Roden Crater*, lithograph
James Turrell, 1995

6.17 *Roden Crater*, diagram
James Turrell



6.15

It is virtually impossible to look at the workings of the sky without somehow being moved by it. There is no greater teacher of time and space than the sky, no greater courier to the sense of majesty, no greater dwarfing of one's own significance, and no greater prompter to the question of 'why'. To watch and interpret the skies has always been one of man's most basic instincts, providing a way of placing oneself in the context of the universe.

Richard Bright
on James Turrell, *Eclipse*⁵⁴

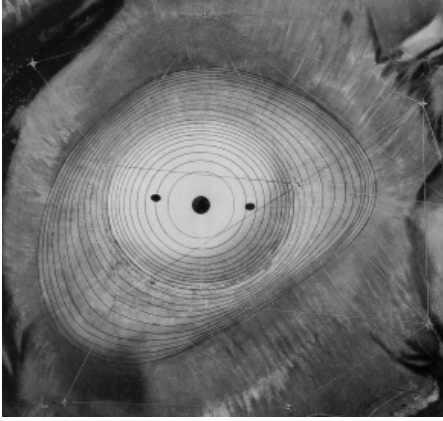

6.16

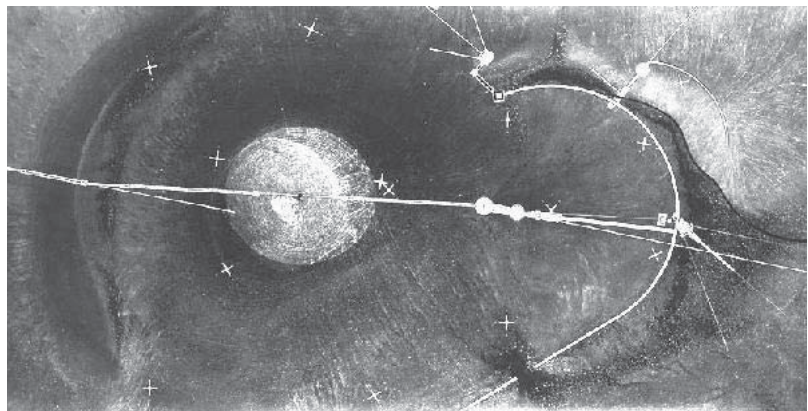

6.17



6.18

6.18 *View of sky from within Roden Crater, 1981*

6.19 *Corridor to a Sky Space, Roden Crater, 2006*

6.20 *A sky space at Roden Crater*

What is important to me is to create an experience of wordless thought, to make the quality and sensation of light itself something really quite tactile. It has a quality seemingly intangible, yet it is physically felt.

James Turrell *quoted in
The Art of Light and Space*⁵⁵



6.20



6.19

6.21 *Roden Crater*
James Turrell, 1979 to present
(NE of Flagstaff, Arizona)

Articles found. The blue distance that never gives way to foreground or dissolves at our approach, which is not revealed spread-eagle and long-winded when reached but only looms more compact and threatening, is the painted distance of a backdrop. It is what gives stage sets their incomparable atmosphere.

Walter Benjamin
One-Way Street ⁵⁶



6.21

[5]

OBJECTS

To miniaturize is to make portable – the ideal form of possessing things for a wanderer, or a refugee. Benjamin, of course, was both a wanderer, on the move, and a collector, weighed down by things; that is, passions. To miniaturize is to conceal. Benjamin was drawn to the extremely small as he was to whatever had to be deciphered: emblems, anagrams, handwriting. To miniaturize is to make useless. For what is so grotesquely reduced is, in a sense, liberated from its meaning – its tininess being the outstanding thing about it. It is both a whole (that is, complete) and a fragment (so tiny, the wrong scale). It becomes an object of disinterested contemplation or reverie.

Susan Sontag on Walter Benjamin

*Under the Sign of Saturn*⁵⁷

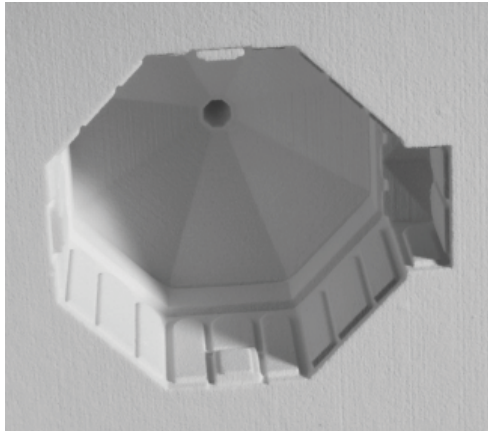

7.01

7.01 *Outside Baptistery*

112 x 112 x 84 mm
scale - 1:1000
starch, glue

7.02 *Inside Baptistery*

65 x 57 x 74 mm
scale - 1:1000
starch, glue

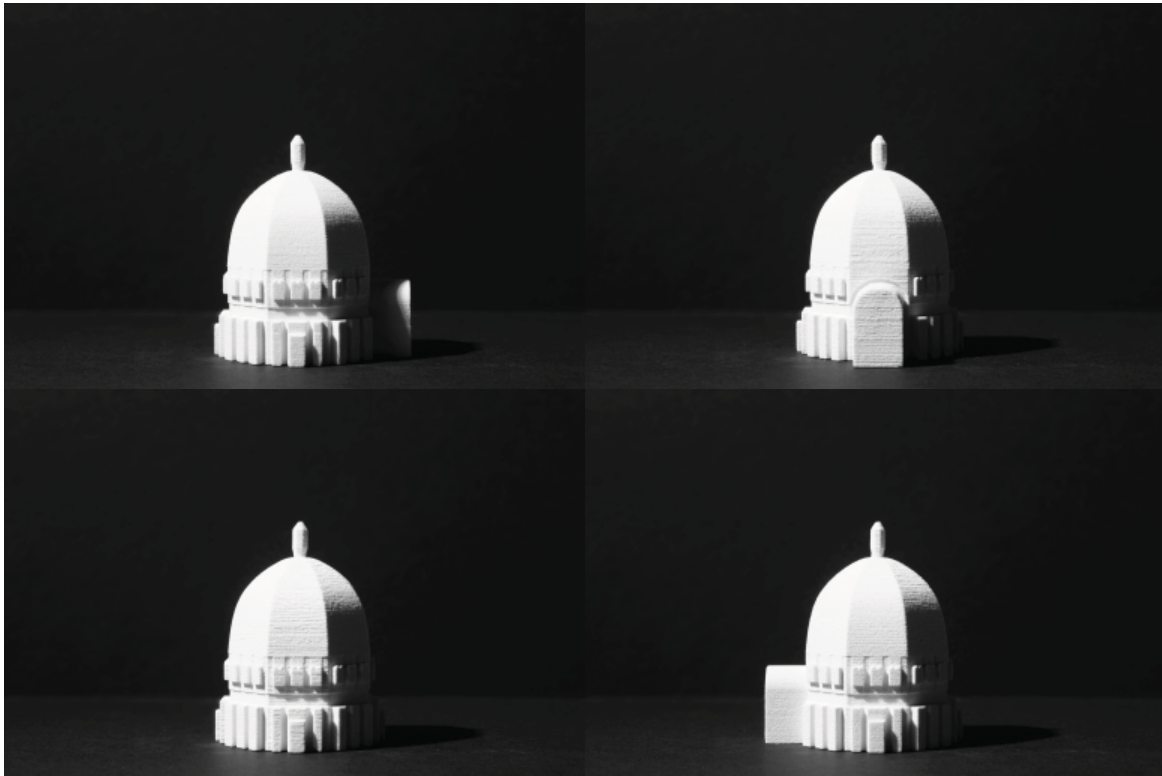

7.02

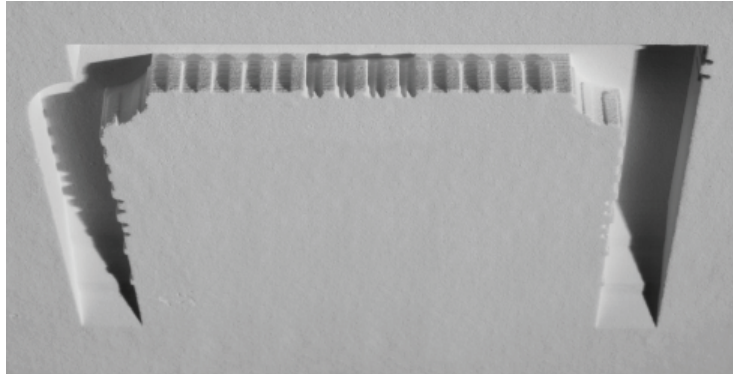

7.03

7.03 *Outside Orangerie*
196 x 161 x 16 mm
scale - *approx.* 1: 1250
starch, glue

7.04 *Inside Orangerie*
140 x 98 x 11 mm
scale - *approx.* 1: 1250
starch, glue

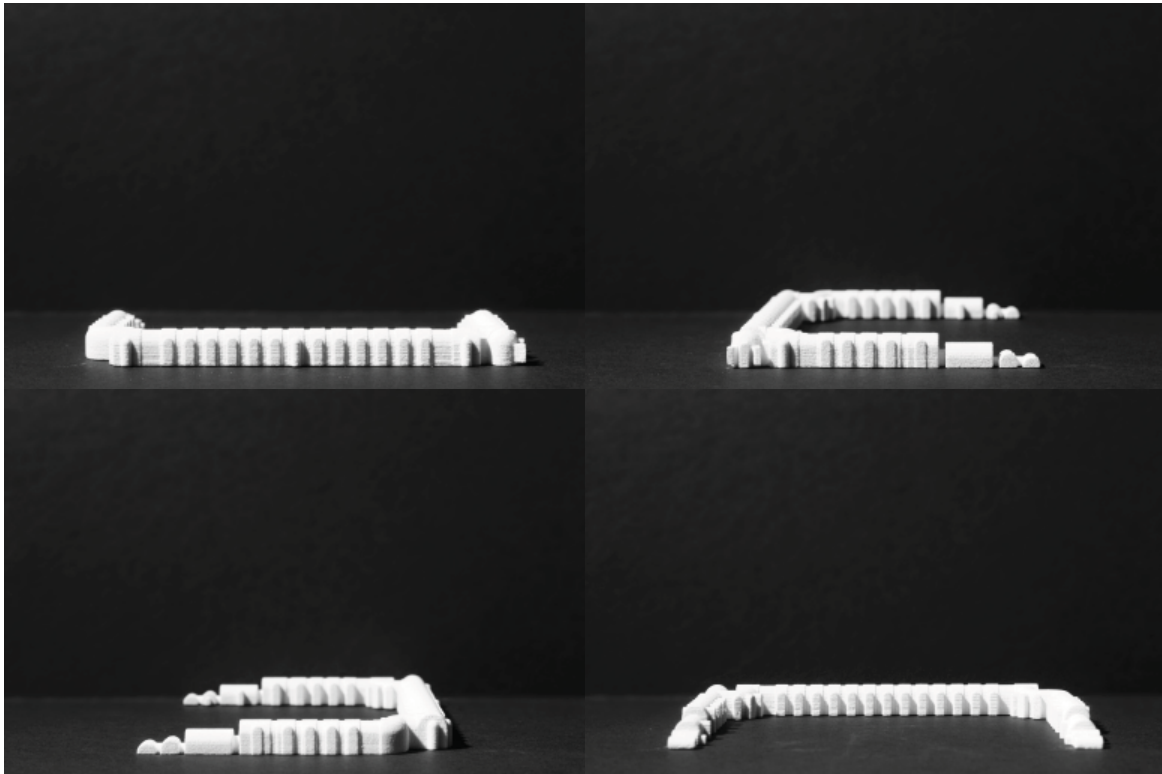

7.04

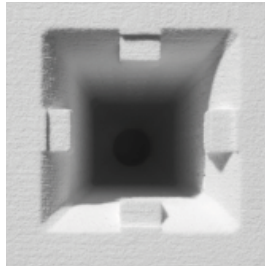

7.05

7.05 *Outside Coney Island*

103 x 103 x 127 mm
scale - 1:1000
starch, glue

7.06 *Inside Coney Island*

20 x 20 x 81 mm
scale - 1:1000
starch, glue

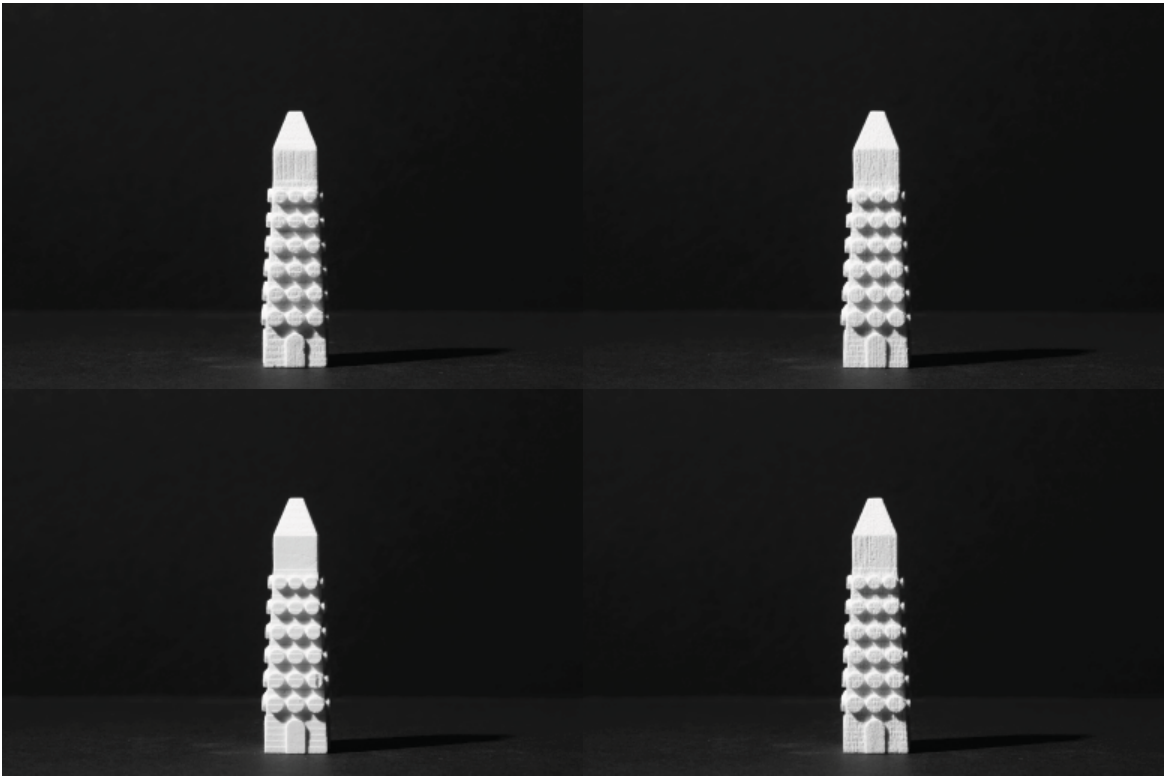

7.06

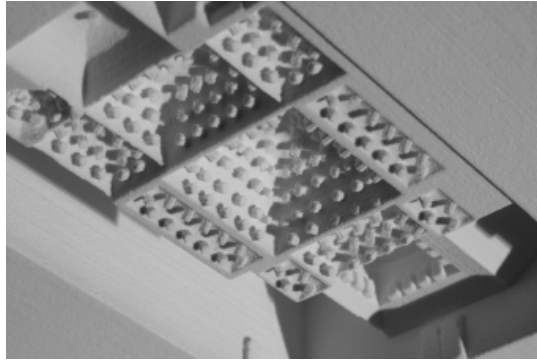

7.07

7.07 *Outside Albambra*

180 x 137 x 42 mm
scale - 1:1000
starch, glue

7.08 *Inside Albambra*

117 x 76 x 49 mm
scale - 1:1000
starch, glue

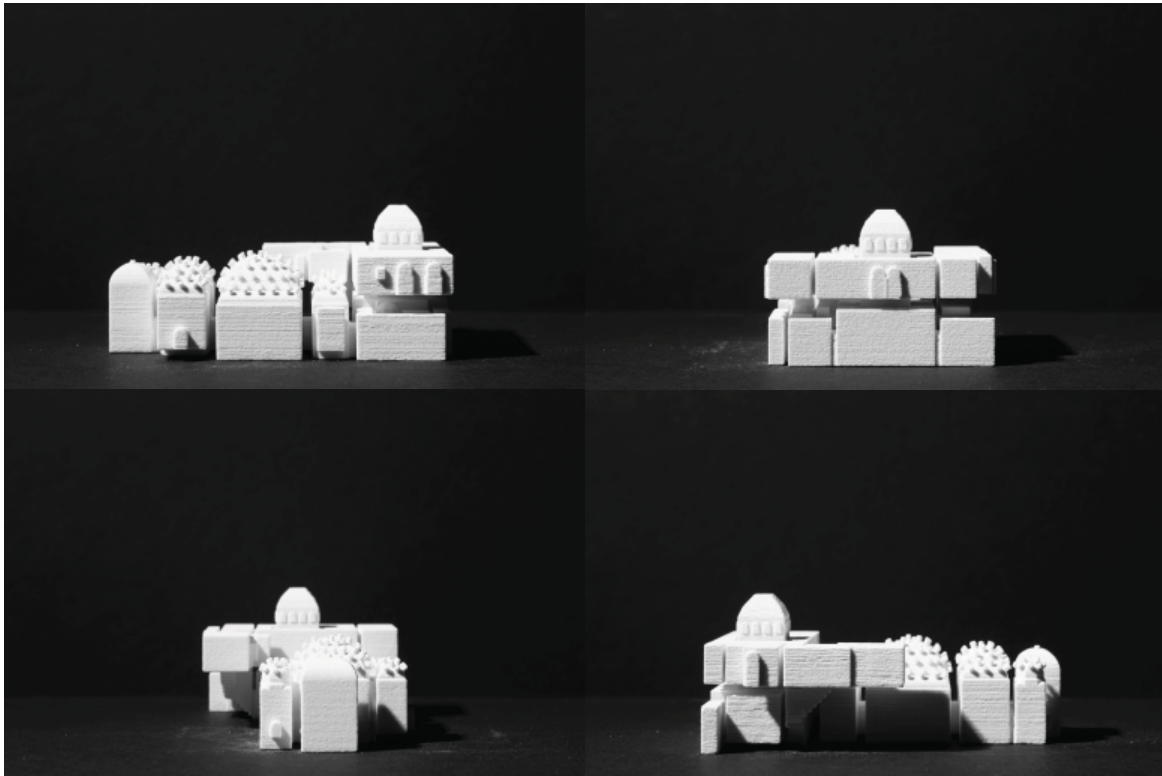

7.08

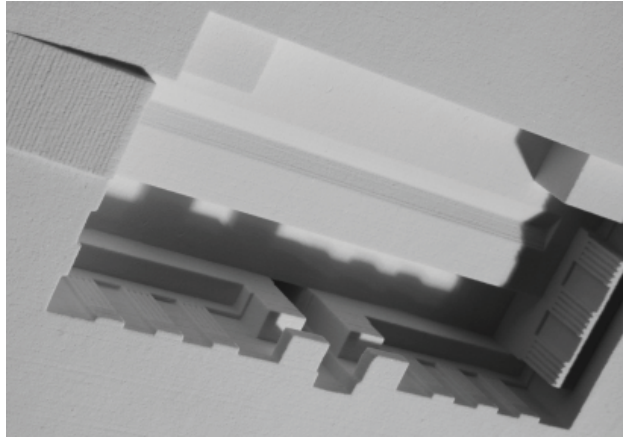

7.09

7.09 *Outside Tate Modern*
233 x 158 x 105 mm
scale - 1:1000
starch, glue

7.10 *Inside Tate Modern*
157 x 25 x 33 mm
scale - 1:1000
starch, glue

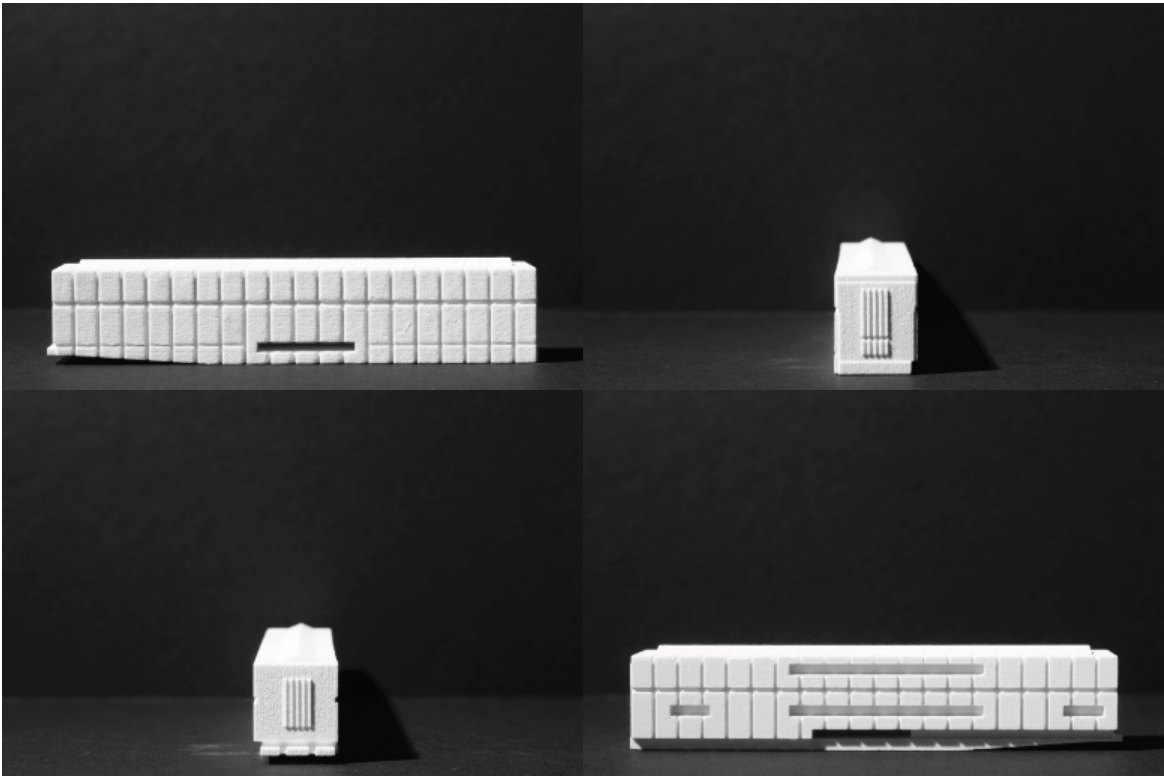

7.10

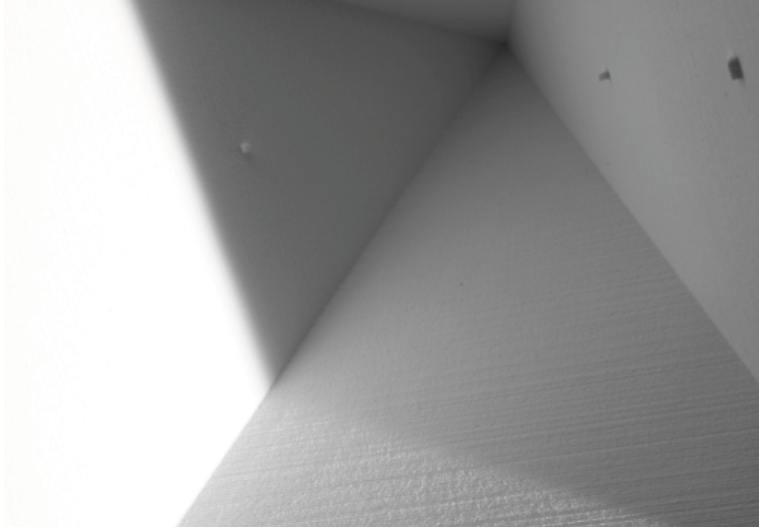

7.11

7.11 *Outside Pyramid*
223 x 177 x 117 mm
scale - *approx.* 1: 1250
starch, glue

7.12 *Inside Pyramid*
117 x 60 x 100 mm
scale - *approx.* 1: 1250
starch, glue

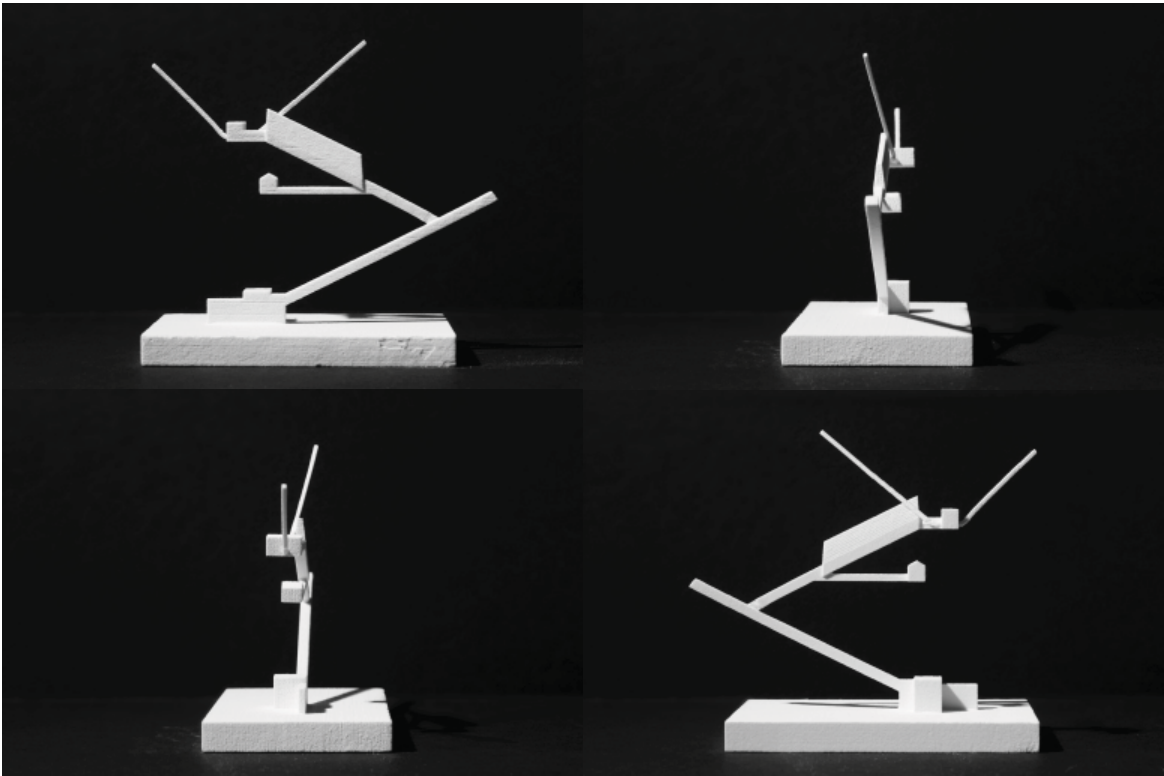

7.12

[6]

EXHIBITION

Art, be it painting, literature, or architecture, is the remaining shell of thought. Actual thought is of no substance. We cannot actually see thought, we can only see its remains. Thought manifests itself by shucking or shedding its remains. It is beyond its confinement.

John Hejduk
*Evening in Llano*⁵⁸

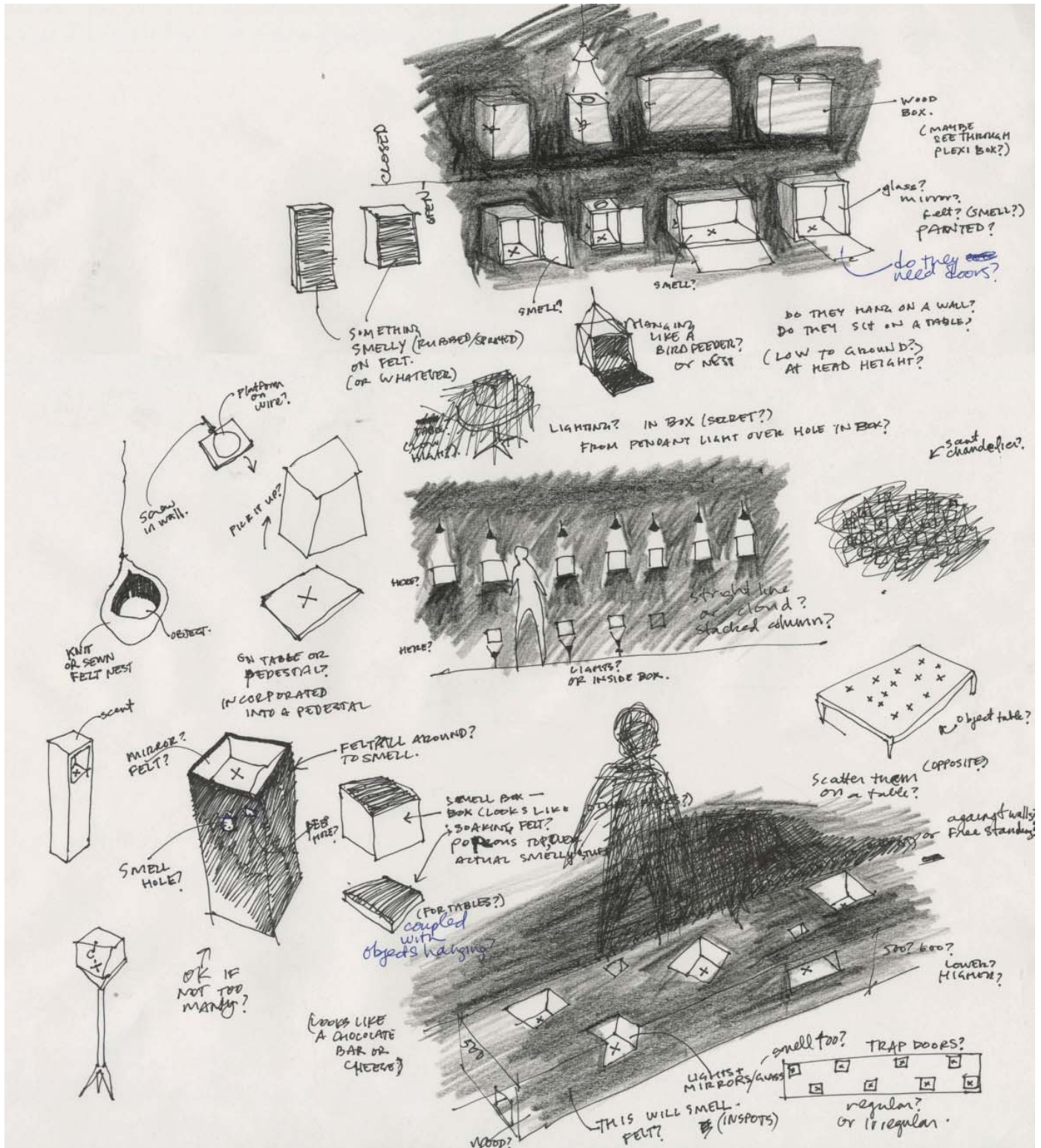

December 3, 2009

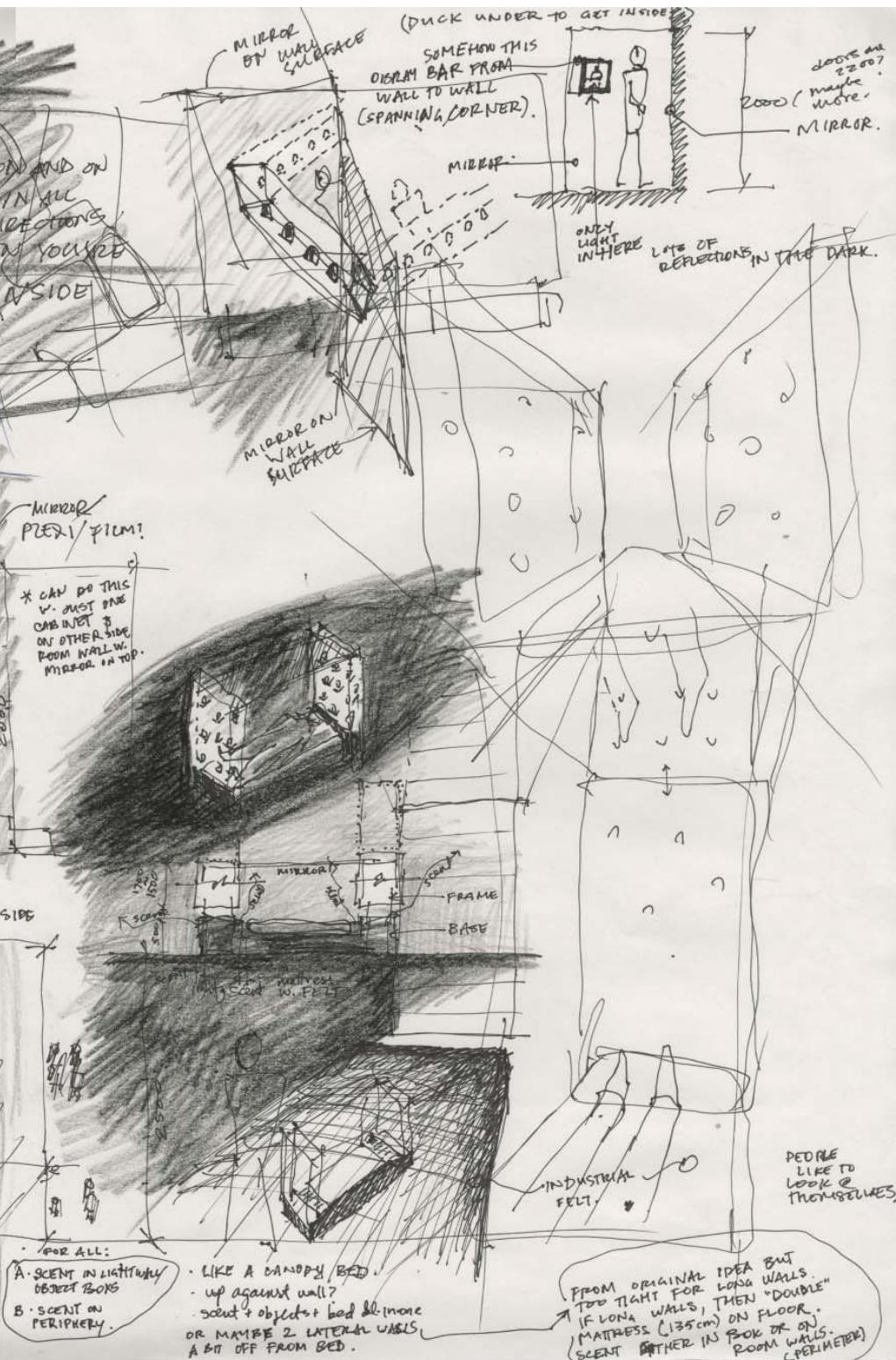

December 3, 2009

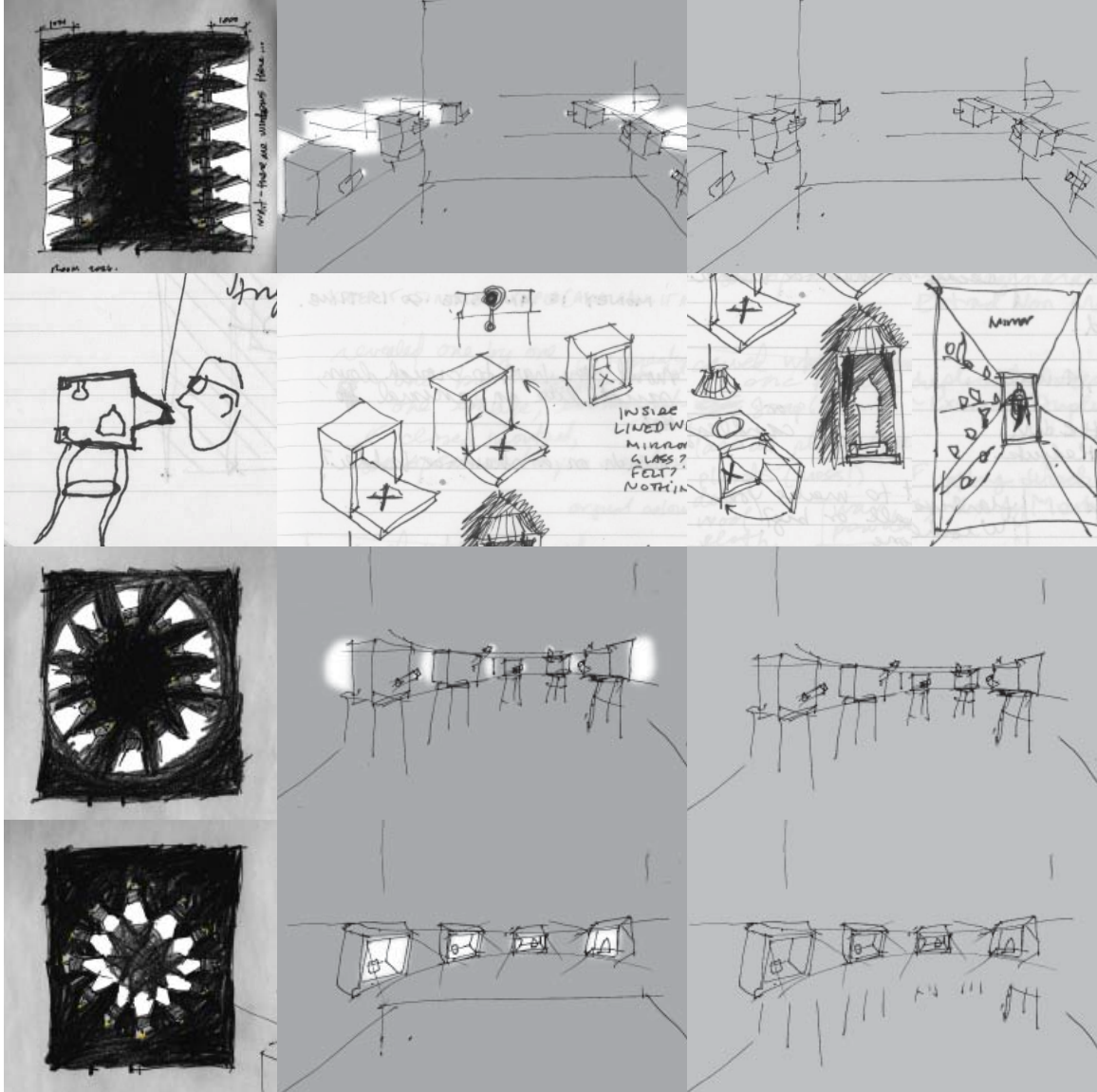

November 8, 2009 to January 26, 2010



January 25, 2010 to July 29, 2010



February 7, 2010 to March 17, 2010



September 9, 2011 to September 16, 2011



January 13, 2012

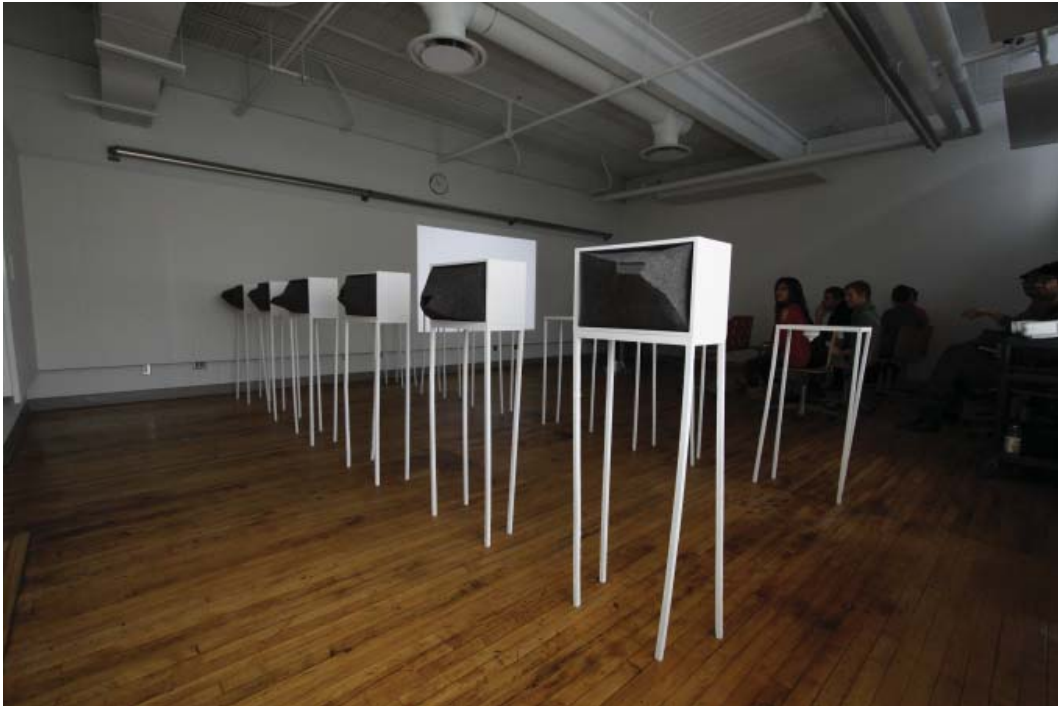

January 13, 2012

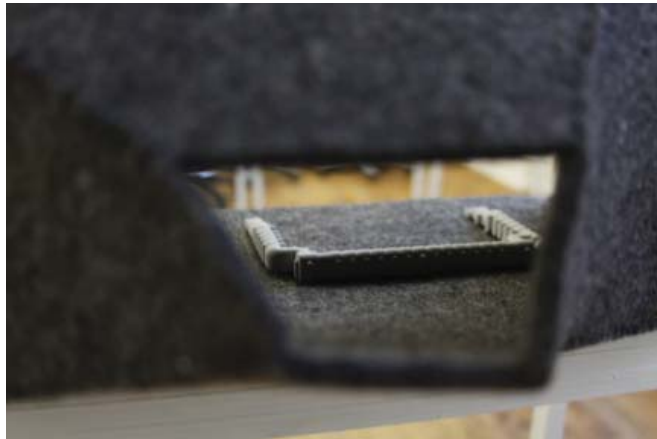

January 13, 2012

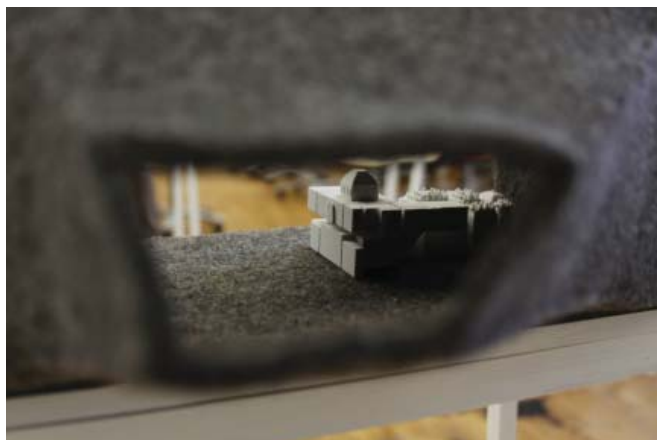

January 13, 2012



January 13, 2012



January 13, 2012

[0]

POSTSCRIPT

An attempt to explain:

Architecture is capable of many things. It can provide everyday comfort, lend structure to our communities, explore the frontiers of technology, facilitate environmental remediation, affect social change for better or worse, and give us means to look at ourselves and our histories, values, and ideals. As a whole it is many things, a force that isn't easily seen or grasped despite the largeness and physicality of its agents. Architecture is too gigantic, overwhelming; its breadth too vast, its depths elusive, so frustrating and wonderful at the same time.

Architecture is usually seen in its parts – buildings that populate our cities, façades that form our streets, elements that shelter us from the wind and rain. At first glance it can seem straightforward and utilitarian, but it also works below the surface, in unexpected ways. Like all art, it has the ability to negotiate the boundaries of human experience and connect us to a world beyond the literal or visible; it moves between the individual and the collective, material and metaphysical, bridging the sea between disparate places and times.

We often look to the past to ground us, perhaps for a little security in ever-accelerating times. In the *now* the air feels unstable, too fluid, charged with the pressure of history and immanent trajectory - full of promise but also uncertainty. We look back even as we know history and memory are constantly evolving mythologies, themselves dynamic and alive. The stability we project onto the past is deceptive, especially from a distance.

For this thesis, six places were studied, modelled, and printed into small objects. Five of these six places are only shadows of what they once were. For moments in time, these five shone at the centre of their respective universes. Each place held human lives in moments of immediacy and present-ness, blurring the line of inner and outer worlds for their inhabitants. But time passes and the centre shifts. In turn, they have all, in one way or another, been abandoned. Time and time again, they have been re-discovered, re-imagined, re-possessed, and re-consumed. In some lives they were revered, cared for, joyfully lived in. In others, they were forgotten, dismantled, buried in sand. Presently they stand – the five: the Baptistery, the Orangerie, Coney Island, the Alhambra, and the Pyramid – propped at the edge in a sort of slumber, neither here nor there.

The exception, the Tate Modern, is quite different. The youngest of the six, its walls were originally built upon prominent but contested ground. As Bankside Power Station, it was a fortress, isolated, impenetrable, the domain of oil and machines for twenty-nine years. Now, after years of disuse, it is alive with people and regarded as a vital piece of its city.

These six places are themselves, and they are also other things. They contain traces of other times, and embody other people and places. The baptistery in Florence was a threshold between earth and heaven, through which people were reborn into a Biblical world. The orangerie at Versailles was a hidden backdrop for the French court's political theatre, all the while giving life to exotic fruit. Coney Island's Electric Tower was all exterior, an illuminated sign to mark a place of congregation and release in celebration of the American Dream. The bath at the Alhambra was a space of meditation and reflection, giving careful views of the world inside and out. Inside the Tate Modern, the massive Turbine Hall was transformed into a nested vessel for common, intimate encounters with art. The pyramid, at its peak, was a portal to the stars and horizon, giving order to the universe and meaning to life and death.

Architecture is all of these: door, stage, pylon, frame, room, and passage. It is both foreground and background – sometimes the object, sometimes the subject – and we who move through it also change between the two.

This exhibition takes what is large, shared, and gigantic in space and time and brings it together to this one room, to this moment, and to the inches between viewer and viewed. Miniaturized and stripped bare, we can now surround these monuments, enclose them until they might move, captured and contained, through us.

NOTES

- 1 Allen S. Weiss, *Mirrors of Infinity: The French Formal Garden and 17th-Century Metaphysics* (New York: Princeton Architectural Press, 1995), 9.
- 2 James Gleick, *The Information: A History, a Theory, a Flood* (New York: Pantheon Books, 2011), 31.
- 3 Rachel Whiteread, "Working Notes" in Louise Neri, *Looking Up: Rachel Whiteread's Water Tower* (New York: Public Art Fund, 1999), 139.
- 4 Jorge Luis Borges, "The Garden of Forking Paths," transl. Donald A. Yates, in Borges, *Labyrinths: Selected Stories & Other Writings* (New York: New Directions, 1964), 28.

DOOR

- 5 Elise Rasmussen, on her series "Stendhal Syndrome," <http://www.eliserasmussen.com/work/stendhal/>
- 6 The quote used is an unsourced translation found widely on the internet. It can be located here: <http://www.wordspy.com/words/Stendhalssyndrome.asp>.
Original full quotation in French is as follows:
"Là, assis sur le marche-pied d'un prie-Dieu, la tête renversée et appuyée sur le pupitre, pour pouvoir regarder au plafond, les Sibylles du Volterrano m'ont donné peut-être le plus vif plaisir que la peinture m'ait jamais fait. J'étais déjà dans une sorte d'extase, par l'idée d'être à Florence, et le voisinage des grands hommes dont je venais de voir les tombeaux. Absorbé dans la contemplation de la beauté sublime, je la voyais de près, je la touchais pour ainsi dire. J'étais arrivé à ce point d'émotion où se rencontrent les *sensations célestes* données par les beaux-arts et les sentiments passionnés. En sortant de Santa Croce, j'avais un battement de cœur, ce qu'on appelle des nerfs à Berlin ; la vie était épuisée chez moi, je marchais avec la crainte de tomber."^{6a}
- 6a Stendhal, *Rome, Naples et Florence*, (Paris: Michel Lévy Frères Libraires-éditeurs, 1854), 206-207.
- 7 Conversation between Graziella Magherini and Maria Barnas in Maria Barnas, "Confrontations: An Interview with Florentine Psychiatrist Graziella Magherini," *Metropolis M* No.4 (2008)
- 8 Alexander Roberts, James Donaldson, and A. Cleveland Coxe, eds., *The Ante-Nicene Fathers: Translations of the Writings of the Fathers Down to A.D. 325, Vol.7* (Buffalo: Christian Literature Pub. Co., 1886), 431.

STAGE

- 9 Guy Walton, *Louis XIV's Versailles* (Chicago: University of Chicago Press, 1986), 7.
- 10 Katherine Ashenburg, *The Dirt on Clean: An Unsanitized History* (Toronto: Alfred A. Knopf Canada, 2007), 116.
- 11 Patrick Suskind, *Perfume: The Story of a Murderer* (London: Penguin, 1987), 1.

- 12 Chandra Mukerji, *Territorial Ambitions and the Gardens of Versailles* (Cambridge: Cambridge University Press, 1997), 198.
- 13 Jacques Levron and Claire Eliane Engel, *Daily Life at Versailles in the Seventeenth and Eighteenth Centuries* (London: George Allen and Unwin Ltd., 1968), 76.
- 14 Mukerji, *Territorial Ambitions*, 198.
- 15 Allen S. Weiss, *Mirrors of Infinity: The French Formal Garden and 17th-Century Metaphysics* (New York: Princeton Architectural Press, 1995), 72.
- 16 Mukerji, *Territorial Ambitions*, 13.
- 17 Weiss, *Mirrors of Infinity*, 68.
- 18 Robert Harbison, *The Built, the Unbuilt, and the Unbuildable: In Pursuit of Architectural Meaning* (London: Thames and Hudson, 1991), 8.

P Y L O N

- 19 Susan Stewart, *On Longing: Narratives of the Miniature, the Gigantic, the Souvenir, the Collection* (Durham: Duke University Press, 1993), 60.
- 20 Michael Immerso, *Coney Island: The People's Playground* (Piscataway, NJ: Rutgers University Press, 2002), 8.
- 21 Rem Koolhaas, *Delirious New York: A Retroactive Manifesto for Manhattan* (New York: Monacelli Press, 1994), 46.
- 22 Ibid., 30.
- 23 John F. Kasson, *Amusing the Million : Coney Island at the Turn of the Century* (New York: Hill & Wang, 1978), 53.
- 24 Immerso, *The People's Playground*, 66.
- 25 Kasson, *Amusing the Million*, 50.
- 26 Immerso, *The People's Playground*, 6.
- 27 Koolhaas, *Delirious New York*, 42.
- 28 Immerso, *The People's Playground*, 8.

F R A M E

- 29 Edward Rothstein, "Temptations found in Gardens of Islamic Delight," *The New York Times* (May 20, 2011), <http://www.nytimes.com/2011/05/21/arts/design/spanish-paradise-gardens-of-the-alhambra-at-the-new-york-botanical-garden-review.html>
- 30 Robert Irwin, *The Alhambra* (Cambridge: Harvard University Press, 2004), 57.
- 31 Ibid., 28.
- 32 Oleg Grabar, *The Alhambra* (Cambridge: Harvard University Press, 1978), 114.
- 33 Ibid., 185.
- 34 Ibid., 208.
- 35 Irwin, *The Alhambra*, 50.
- 36 Grabar, *The Alhambra*, 208.
- 37 Ibid., 117.

ROOM

- 38 Conversation between Jacques Herzog and Philip Ursprung in *Herzog & De Meuron Natural History* (Montreal: Canadian Centre for Architecture, 2002), 364-365.
- 39 Conversation between Nicholas Serota and Rowan Moore in *Building Tate Modern: Herzog & De Meuron Transforming Giles Gilbert Scott* (London: Tate Gallery, 2000), 54.
- 40 Conversation between Rachel Whiteread and Richard Lacayo in “A Talk with: Rachel Whiteread,” *Time* (Oct 21, 2008).
- 41 Conversation between Olafur Eliasson and Hans-Ulrich Obrist in *Olafur Eliasson* (Köln: Walther König, 2008), 41.
- 42 Patrick Mauriès, *Cabinets of Curiosities* (London: Thames & Hudson, 2002), 114.
- 43 *Ibid.*, 12.
- 44 Moore, *Building Tate Modern*, 10.

PASSAGE

- 45 Walter Benjamin, “One-Way Street” in *Reflections: Essays, Aphorisms, Autobiographical Writings*, ed. Peter Demetz (New York: Harcourt Brace Jovanovich, 1978), 83. [first half of *Lost-property Office*]
- 46 Zahi A. Hawass, *Mountains of the Pharaohs: The Untold Story of the Pyramid Builders* (New York: Doubleday, 2006), 56.
- 47 Kevin Jackson and Jonathan Stamp, *Building the Great Pyramid* (Toronto: Firefly Books, 2003), 106.
- 48 Hawass, *Mountains of the Pharaohs*, 24.
- 49 J. P. Lepre, *The Egyptian Pyramids: A Comprehensive, Illustrated Reference* (Jefferson, N.C.: McFarland, 1990), 15.
- 50 Jackson, *Building the Great Pyramid*, 34.
- 51 *Ibid.*, 105-106.
- 52 Hawass, *Mountains of the Pharaohs*, 77-78.
- 53 Stewart, *On Longing*, 71.
- 54 Richard Bright, “Eclipse” from *James Turrell: Eclipse* (London: Michael Hue-Williams Fine Art, 1999), 11.
- 55 James Turrell quoted in Craig Adcock, *James Turrell: The Art of Light and Space* (Berkeley: University of California Press, 1990), 2.
- 56 Benjamin, “One-Way Street,” 83. [second half of *Lost-property Office*]
- 57 Susan Sontag, “Under the Sign of Saturn,” in *Under the Sign of Saturn* (New York: Farrar, Straus & Giroux, 1980), 124.
- 58 John Hejduk, “Evening in Llano,” in *Education of an Architect*, ed. Elizabeth Diller et al. (New York : Rizzoli International, 1988), 340.

BIBLIOGRAPHY

IN GENERAL

- Ackerman, Diane. *A Natural History of the Senses*. 1st ed. New York: Random House, 1990.
- Bachelard, Gaston and M. Jolas. *The Poetics of Space* [Poétique de l'espace.]. Boston: Beacon Press, 1994.
- Barbara, Anna and Anthony Perliss. *Invisible Architecture: Experiencing Places through the Sense of Smell*. Milano: Skira, 2006.
- Barthes, Roland. *Incidents* [Incidents. English. 1992]. Berkeley: University of California Press, 1992.
- Benjamin, Walter and Peter Demetz. *Reflections: Essays, Aphorisms, Autobiographical Writings*. New York: Harcourt Brace Jovanovich, 1978.
- Berger, John. *About Looking*. New York: Vintage International, 1991.
- Borges, Jorge Luis. *Labyrinths : Selected Stories & Other Writings*. New York: New Directions Pub. Corp, 1964.
- Burton, Robert. *The Language of Smell*. London ; Boston: Routledge & Kegan Paul, 1976.
- Classen, Constance, David Howes, and Anthony Synnott. *Aroma: The Cultural History of Smell*. London: Routledge, 1994.
- Diller, Elizabeth, Diane Lewis, and Kim Shkapich, eds. *Education of an Architect*. New York : Rizzoli International, 1988.
- Drobnick, Jim. *The Smell Culture Reader*. Sensory Formations Series. English ed. New York: Berg, 2006.
- Forsyth, Adrian and Kenneth Miyata. *Tropical Nature*. New York: Scribner, 1984.
- Gilbert, Avery N. *What the Nose Knows: The Science of Scent in Everyday Life*. 1st ed. New York: Crown Publishers, 2008.
- Glaser, Gabrielle. *The Nose: A Profile of Sex, Beauty, and Survival*. New York: Atria Books, 2002.
- Gleick, James. *The Information: A History, a Theory, a Flood*. New York: Pantheon Books, 2011.
- Harbison, Robert. *The Built, the Unbuilt, and the Unbuildable: In Pursuit of Architectural*

- Meaning*. London: Thames and Hudson, 1991.
- . *Eccentric Spaces*. A Borzoi Book. 1st ed. New York: Knopf, 1977.
- . *Thirteen Ways: Theoretical Investigations in Architecture*. MIT Press Series in Contemporary Architectural Discourse. Cambridge, Mass.; MIT Press, 1997.
- Hayes, K. Michael, ed. *Hejduk's Chronotope*. New York: Princeton Architectural Press, 1996.
- Herz, Rachel. *The Scent of Desire: Discovering our Enigmatic Sense of Smell*. 1st ed. New York: William Morrow, 2007.
- Mckenzie, Dan. *Aromatics and the Soul: A Study of Smells*. New York, P.B. Hoeber, 1923.
- Milutis, Joe. *Ether: The Nothing that Connects Everything*. Minneapolis: University of Minnesota Press, 2006.
- Mitnick, Keith. *Artificial Light: A Narrative Inquiry into the Nature of Abstraction, Immediacy, and Other Architectural Fictions*. New York: Princeton Architectural Press, 2008.
- Pallasmaa, Juhani. *The Eyes of the Skin: Architecture and the Senses*. Polemics. London: Academy Editions, 1996.
- Schwenger, Peter. *The Tears of Things: Melancholy and Physical Objects*. Minneapolis: University of Minnesota Press, 2006.
- Sebald, Winfried Georg. *On the Natural History of Destruction* [Luftkrieg und Literatur.]. 1 US ed. New York: Random House, 2003.
- Sontag, Susan. *Under the Sign of Saturn*. New York: Farrar, Straus & Giroux, 1980.
- Stewart, Susan. *On Longing: Narratives of the Miniature, the Gigantic, the Souvenir, the Collection*. Durham: Duke University Press, 1993.
- Stoddart, D. Michael. *The Scented Ape: The Biology and Culture of Human Odour*. Cambridge: Cambridge University Press, 1990.
- Watson, Lyall. *Jacobson's Organ and the Remarkable Nature of Smell*. 1 American ed. New York: W.W. Norton, 2000.
- Weschler, Lawrence. *Everything that Rises: A Book of Convergences*. San Francisco, Calif.: McSweeney's Books, 2006.

SAN GIOVANNI BAPTISTERY

- Angiola, Eloise M. "Gates of Paradise and the Florentine Baptistery." *The Art Bulletin* 60, no. 2 (June, 1978): 242-248.
- Barnas, Maria. "Confrontations: An Interview with Florentine Psychiatrist Graziella Magherini." *Metropolis M* no. 4 (Aug/Sept, 2008), <http://metropolism.com/magazine/2008-no4/confrontaties/english>
- Busignani, Alberto and Raffaello Bencini. *Le Chiese Di Firenze*. Firenze: Sansoni, 1974.
- Fanelli, Giovanni. *Firenze, Architettura e Città*. Firenze: Vallecchi, 1973.
- Goy, Richard J. *Florence: The City and its Architecture*. New York: Phaidon, 2002.
- Guy, Melinda. "The Shock of the Old." *Frieze* no. 72 (January - February, 2003), http://www.frieze.com/issue/article/the_shock_of_the_old/
- Magherini, Graziella, *La Sindrome Di Stendhal*, <http://www.auxologia.it/stendhalsyndrome/>
- McFredies, Paul. "Stendhals syndrome," *Wordspy*, <http://www.wordspy.com/words/Stendhalssyndrome.asp>.
- Mitchell, Brendon, "The Sacrament of Baptism - the Door of the Church," *Fully Catholic*, <http://www.fullycatholic.com/catholic-faith/sacraments/46-baptism/402-the-sacrament-of-baptism-the-door-of-the-church>
- Pomazansky, Michael, "The Mystery of Baptism," *Orthodox America*, <http://www.roca.org/OA/36/36p.htm>
- Rasmussen, Elise, "Stendhal Syndrome," *Elise Rasmussen*, <http://www.eliserasmusen.com/work/stendhal/>
- Roberts, Alexander, James Donaldson, and A. Cleveland Coxe, eds. *The Ante-Nicene Fathers: Translations of the Writings of the Fathers Down to A.D. 325, Vol. 7*. Buffalo, Christian Literature Pub. Co., 1886. (<http://books.google.ca/books?id=ko0sAAAAYAAJ>)
- Stendhal. *Rome, Naples et Florence*, (Paris: Michel Lévy Frères Libraires - éditeurs, 1854). (<http://books.google.com/ebooks/reader?id=BS0LAAAAYAAJ>)
- Unsigned, "Baptism," *New Advent Catholic Encyclopedia*, <http://www.newadvent.org/cathen/02258b.htm>
- Unsigned, "Baptism – the Door to the Life of Grace," *Diocese of La Crosse*, http://www.dioceseoflacrosse.com/ministry_resources/catechesis/cat7_baptism.pdf
- Unsigned, "Baptistry of Florence," *The Museums of Florence*, http://www.museum-sinflorence.com/musci/Baptistry_of_florence.html

- Unsigned, "Florence Baptistery - Florence, Italy," *Sacred Destinations*, <http://www.sacred-destinations.com/italy/florence-baptistery>
- Unsigned, "The Cathedral of S. Maria Del Fiore," *Florence's Duomo*, <http://www.duomofirenze.it/index-eng.htm>
- Unsigned, "The Gates of Paradise: Lorenzo Ghiberti's Renaissance Masterpiece," *The Art Institute of Chicago*, <http://www.artic.edu/aic/exhibitions/ghiberti/themes.html>
- Unsigned, "Opera Di Santa Maria Del Fiore Di Firenze." *Opera Duomo Firenze*, <http://www.operaduomo.firenze.it/english/storia/>
- Unsigned, "Stendhal syndrome," *Wikipedia*, http://en.wikipedia.org/wiki/Stendhal_syndrome

VERSAILLES

- Angeloglou, Maggie. *A History of Make-Up*. London: Studio Vista, 1970.
- Ashenburg, Katherine. *The Dirt on Clean: An Unsanitized History*. Toronto: Alfred A. Knopf Canada, 2007.
- Baridon, Michel. *A History of the Gardens of Versailles*. Philadelphia: University of Pennsylvania Press, 2008.
- Berger, Robert W. *In the Garden of the Sun King*. Washington, D.C.: Dumbarton Oaks Research Library and Collection, 1985.
- Corbin, Alain. *The Foul and the Fragrant: Odor and the French Social Imagination* [Miasme et la jonquille.]. Leamington Spa: Berg, 1986.
- Dubois, Jacques, Jean d'Ormesson, Robert Doisneau, Pierre Arizzoli-Clémentel, and Mary Christian. *Versailles, a Garden in Four Seasons* [Versailles aux quatre saisons.]. New York: Harry N. Abrams, 2005.
- Szanto, Catherine. "A graphical analysis of Versailles garden promenades." *Journal of Landscape Architecture: JoLA*. (Spring 2010): 52-59.
- Graafland, Arie. *Versailles and the Mechanics of Power: The Subjugation of Circe : An Essay*. Critical Landscape. Rotterdam: 010 Publishers, 2003.
- Herlihy, David and Samuel Kline Cohn. *The Black Death and the Transformation of the West*. Cambridge, Mass.: Harvard University Press, 1997.
- Kelly, John. *The Great Mortality: An Intimate History of the Black Death, the most Devastating Plague of all Time*. 1st ed. New York: HarperCollins Publishers, 2005.

- Lablaude, Pierre-André. *The Gardens of Versailles*. London: Zwemmer, 1995.
- Levron, Jacques and Claire Eliane Engel. *Daily Life at Versailles in the Seventeenth and Eighteenth Centuries*. London: George Allen and Unwin Ltd., 1968.
- Mukerji, Chandra. *Territorial Ambitions and the Gardens of Versailles*. Cambridge Cultural Social Studies. Cambridge: Cambridge University Press, 1997.
- Pointer, Sally. *The Artifice of Beauty: A History and Practical Guide to Perfumes and Cosmetics*. Stroud: Sutton, 2005.
- Saule, Béatrix and Jean-Baptiste Leroux. *Versailles Gardens* [Versailles, cote jardins]. New York, NY; New York: Vendome Press; Distributed in the USA and Canada by Rizzoli, 2002.
- Suskind, Patrick. *Perfume: The Story of a Murderer*. London: Penguin Books, 1987; 1986.
- Walton, Guy. *Louis XIV's Versailles*. Chicago: University of Chicago Press, 1986.
- Weiss, Allen S. *Mirrors of Infinity: The French Formal Garden and 17th-Century Metaphysics*. New York: Princeton Architectural Press, 1995.
- Woodbridge, Kenneth. *Princely Gardens: The Origins and Development of the French Formal Style*. New York: Rizzoli, 1986.
- Woods, May. *Glass Houses: A History of Greenhouses, Orangeries and Conservatories*. Arete Swartz Warren, ed. New York: Rizzoli, 1988.

CONEY ISLAND

- Devitt, Nora, Samantha Nemeth, Caitlin Phillips and Ryan Lintelman, "Coney Island and the Modernization of America," *William & Mary American Studies*, <http://web.wm.edu/americanstudies/370/2007/sp8/>
- Immerso, Michael. *Coney Island: The People's Playground*. New Brunswick ; Piscataway, NJ: Rutgers University Press, 2002.
- Kasson, John F., 1944. *Amusing the Million : Coney Island at the Turn of the Century*. American Century Series. New York: Hill & Wang, 1978.
- Koolhaas, Rem. *Delirious New York: A Retroactive Manifesto for Manhattan*. New ed. New York: Monacelli Press, 1994.
- Ryan, Zoë and Jonathan Cohen-Litant. *Coney Island: The Parachute Pavilion Competition*. New York: Van Alen Institute : Princeton Architectural Press, 2007.

Unsigned, *Coney Island History Project*, <http://www.coneyislandhistory.org/index.php>

Unsigned, "An Elephant Dies at Coney Island," *Ephemeral New York*, <http://ephemeralnewyork.wordpress.com/2010/06/02/an-elephants-death-at-coney-island/>

THE ALHAMBRA

Allen, Terry, "Uses of Symmetry in Architecture," *Constructs of Symmetry in Islamic Art*, <http://sonic.net/~tallen/palmtree/symmetries/section.three.symm.htm#ct.lions.sect>.

Bachelard, Gaston. *Water and Dreams: An Essay on the Imagination of Matter*. The Bachelard Translations. [Eau et les rêves.]. Dallas: Pegasus Foundation, 1983.

de Bonneville, Françoise. *The Book of the Bath* [Livre du bain.]. New York: Rizzoli, 1998.

Grabar, Oleg. *The Alhambra*. Cambridge, Mass: Harvard University Press, 1978.

Grécy, Jules and Ferdinand Werner. *Die Alhambra Zu Granada*. Worms, Germany: Wernersche, 1990.

Irwin, Robert. *The Alhambra*. Cambridge: Harvard University Press, 2004.

Jacobs, Michael and Francisco Fernández. *Alhambra*. 1 pbk ed. London: Frances Lincoln, 2005.

Koren, Leonard. *Undesigning the Bath*. Berkeley, Calif.: Stone Bridge Press, 1996.

Unsigned, "Baths," *The Alhambra, Granada, Spain*, <http://www.alhambradegranada.org/en/info/placesandspots/alhambrabaths.asp>

TATE MODERN

Ashton, Dore. *A Joseph Cornell Album*. New York: Viking Press, 1974.

Blom, Philipp. *Encyclopédie: The Triumph of Reason in an Unreasonable Age*. London: Fourth Estate, 2004.

Buzas, Stefan and Richard Bryant. *Sir John Soane's Museum, London*. Opus (Berlin, Germany); 14. Tübingen: Wasmuth, 1994.

- Dion, Mark, Colleen Josephine Sheehy, and Frederick R. Weisman Art Museum. *Cabinet of Curiosities: Mark Dion and the University as Installation*. Minneapolis: University of Minnesota Press : published in cooperation with the Weisman Art Museum, 2006.
- Evans, Robert John Weston and Alexander Marr. *Curiosity and Wonder from the Renaissance to the Enlightenment*. Burlington, VT: Ashgate, 2006.
- Lacayo, Richard. "A Talk with: Rachel Whiteread." *Time* (Oct 21, 2008).
- Mauriès, Patrick. *Cabinets of Curiosities*. London: Thames & Hudson, 2002.
- McShine, Kynaston, Dawn Ades, and Museum of Modern Art. *Joseph Cornell*. New York: Museum of Modern Art, 1980.
- Molesworth, Helen. *Part Object Part Sculpture*. Columbus, Ohio; University Park, Pa.: Wexner Center for the Arts, The Ohio State University; Pennsylvania State University Press, 2005.
- Moore, Rowan and Raymond Ryan. *Building Tate Modern : Herzog & De Meuron Transforming Giles Gilbert Scott*. London: Tate Gallery, 2000.
- Neri, Louise. *Looking Up: Rachel Whiteread's Water Tower*. 1st ed. New York: New York: Public Art Fund; Zurich: Scalo, 1999.
- Obrist, Hans-Ulrich and Olafur Eliasson. *Olafur Eliasson*. The Conversation Series. Vol. 13. Köln: Walther König, 2008.
- Olafur Eliasson, Vanessa Hirsch, Friedrich Meschede, and Thomas Worm. *Olafur Eliasson: Dufttunnel : Ein Projekt Für Die Autostadt in Wolfsburg = a Project for the Autostadt in Wolfsburg*. Ostfildern-Ruit: Hatje Cantz, 2005.
- Thoren, Roxi J. "The Deep Grain of Inquiry: Landscape and Identity in Icelandic Art." *Journal of Landscape Architecture* (Spring, 2010): 38.
- Ursprung, Philip. *Herzog & De Meuron Natural History*. Montreal: Canadian Centre for Architecture; Baden, Switzerland: Lars Müller, 2002.
- Weschler, Lawrence. *Mr. Wilson's Cabinet of Wonder*. New York: Vintage Books, 1995.
- Whiteread, Rachel, Christiane Schneider, and Haunch of Venison. *Rachel Whiteread*. London: Haunch of Venison, 2002.
- Wood, Catherine and Gordon Burn. *Rachel Whiteread: Embankment*. The Unilever Series. London: Tate, 2005.

PYRAMID OF KHUFU

- Adcock, Craig E. *James Turrell: The Art of Light and Space*. Berkeley: University of California Press, 1990.
- Gillispie, Charles Coulston and Michel Dewachter. *Monuments of Egypt: The Napoleonic Edition : The Complete Archaeological Plates from La Description De l'Égypte*. Princeton, NJ: Princeton Architectural Press in association with the Architectural League of New York, the J. Paul Getty Trust, 1987.
- Hawass, Zahi. *Mountains of the Pharaohs: The Untold Story of the Pyramid Builders*. New York: Doubleday, 2006.
- Jackson, Kevin and Jonathan Stamp. *Building the Great Pyramid*. Toronto: Firefly Books, 2003.
- Lepre, J. P. *The Egyptian Pyramids: A Comprehensive, Illustrated Reference*. Jefferson, N.C.: McFarland, 1990.
- Turrell, James, Richard Bright, and Paul Schütze. *James Turrell Eclipse*. London: Michael Hue-Williams Fine Art; Ostfildern-Ruit: Hatje Cantz; Distributed in the USA by D.A.P., 1999.
- Vollmann, William T. *Imperial*. New York: Viking, 2009.
- Wilkinson, Richard H. *The Complete Temples of Ancient Egypt*. New York: Thames & Hudson, 2000.



books + yarn!

(birth)
baldwin + moms
purity + original in
clean slate, identity
Baptism. *(spiritual life)*

PLACES

- death → life
- ritual of baptism
- centre.
- Symbolic relationship to church + Jerusalem.
- ambiguous origins/myth.
- evolution of building overtime (as evidenced in form/structure).
- incredibly long time ok.
- heaven/eternity.

(THIS HEARD ON A PLATTER?)
- the story of 50 in the Baptist (comes).

- mass baptism/festivals.
- Haji - festival of colour/hindu.
- Burning Mass.

myth - tree sap/chrism.

Dante's Inferno (he was baptised (image of B.W. Finema) there).

gates of Paradise.

medieval calendar

dirty Medieval life.
people died early.
the Black Plague.

Stendhal's syndrome

smelling salts.
snuff bottles, nasal membrane.

The story + movie Perfume.
Christoph Laudermilch's smell track.

Nose cones doctors wore.

baldwin can smell from moms
afect like 2 min!
medieval baths w. herbs
+ flowers + eating.

bible → What to do in an
emergency?

Images of
dome + cupola?
→ to ring of molecules?

- Turell's light works.
- objects for daylight saving time
by Anais met den Anert
- Francesco Clemente.

(old world)
memories of yards
gardens, being outside
orange

the use of perfume
in Louis XIV's court

how he moved around
his bedroom window
every day.

Find over the top stone and
yell gallery, Louis XIV.
grandeur MAXING out
power exerted,
control in every way.

Culture/cultivation
candide?

- seton sea aquaculture?

medicinal gardens/monks/
apothecaries.

(image of tiny tiny bottles).
- garden eden/virgin + unicorn
gardens

Paris/perfumes.
(the Ice Storm).

- natural history of Palm trees
(w/ log)

- Eliasson's
Dust tunnel.

Plants! (lots of
pics + descriptions).

- Titanic perfumes.

- HARRISON on
gardens.

- Innocence in away.
naivete?

- Luca Turin's
perfume reviews.

- his menagerie of animals?
book perfume
(by killing the thing for its essence)

- how perfume is made.
- Jap cherry blossoms/
mence = none / peat
flowers?

silliness of oranges
(Seville oranges)
we can't eat em.
Prideful, wasteful.

experience of importance of
scent for animals?
chemical sense.
- Susana Soares bee proj.
Animals + detecting illness.

dele Jarmun's garden?

smell of Chlorine?

Comme Des Garçons.

- string gardens.
- coral + mathematical
becket.

Adolescence
hormones, SW
roaming in pac
of identity
Coney Island

historical signi.
coming of age +
movers w. core

mass culture of
amusement +
recreation
- leisure

- Brothel/sex
uninhibited,
body/instinct

- animal form/
novelty

play + pleasure
- Mag to Sept.
SUMMER.

heat
culty + ocean
(Seinfeld?)

Koolhaas Fetal M

Dreamland/
Subconscious/
dream analysis

Franks/oddities
increasing wealth
Tornado/cyclone
Thunderstorms
Fire - destructive
+ Fire performance
scheduled.

Food
- sunnyside/picnic
in Toy

carousels?
consumption
(smells of...
ie groceries
LAS Vegas

seduction
phero hormone
Kavanaugh
Jacobson

Entertainment
Smellonsic

secrets ma
perfume.
MERMAID
cotton candy

Salt water +
popcorn
Ice cream.

- Fantastic
perfume

instead?

- light shows
Madgala fal

- BRIGHAN PA

Kumi Yamashita
shabigot's accept
Tino Sehgal's kiss
Quaylebaum.

RAW MATERIAL

DIRECT QUOTES.
NOTES FROM
BOOKS.

IMAGES.

was next
gymnastic
led later
Bongiorno
Ludovico

Look at
check to
start how
to structure
own work?
3 part
structure.

BLOG

writing.

NOTEBOOKS.

blog bit on Molecules?
- Bee's
- Pollination
- Honey bees
- Smell to make them
- beeswax dozie

WHERE DO YOU FIT?

Hejduk's obedient
or Inhabitant who
refused to participate.
or abandoned cathedral/plungel.
OR SKETCHES.

