

Setting Target Rates for Construction Activity Analysis Categories

by
Maryam Shahtaheri

A thesis
presented to the University of Waterloo
in fulfillment of the
thesis requirement for the degree of
Master of Applied Science
in
Civil Engineering

Waterloo, Ontario, Canada, 2012

©Maryam Shahtaheri 2012

AUTHOR'S DECLARATION

I hereby declare that I am the sole author of this thesis. This is a true copy of the thesis, including any required final revisions, as accepted by my examiners.

I understand that my thesis may be made electronically available to the public.

Abstract

This thesis is focused on increasing productive actions in construction by a procedure known as Activity Analysis. Activity Analysis is a continuous productivity improvement tool for identifying barriers to site productivity with the goal of decreasing them and thereby increasing the direct work rate. A preceding study validated this approach, however it had two limitations. No reevaluation was conducted on projects in Canada by the authors, and not enough resources or data were available to understand behaviour of the activity rates in absolute value terms across many projects. Based on three case studies and data collected over 17 days by the author and a colleague, Activity Analysis was validated as being applicable in Canadian conditions. A desired value, known as a target rate, was then studied in order to be able to set expectations with respect to the productivity to be achieved in each cycle. The premise behind setting a “target rate” is that 100% direct work is neither possible nor desirable, since some time must always be spent on communications and planning. However, a higher direct work rate is generally better than a lower rate. Thus, a target rate is needed. A mathematical model called ANFIS was developed as a means of setting the desired level of activities. Through consideration of a variety of factors that affect labour productivity, the developed model was trained based on 65 data points. The model was found to be easy to use and flexible enough to be appropriate for all of the factors considered. Based on the data points available from 5 different past projects and 3 recent projects and the experience associated with these projects, three additional methods of defining the target rate were developed. The impact of these results is that companies now have appropriate methods and an initial data set for industrial construction in order to establish target rates for direct work and supporting activities. This should help reduce project costs and improve productivity.

Acknowledgements

I would like to express my sincerest appreciation and gratitude to my supervisor, Dr. Carl T. Haas, for his continued guidance and for sharing his knowledge throughout my entire research project. Your support, devotion, motivation, and constant belief in me have assisted me in realizing my potential, and I have appreciated every minute of this journey.

I gratefully acknowledge the financial support of Aecon Industrial, which enabled the successful completion of this work. I would like especially to thank Mr. Jack Gibson, Manager, Construction operations; Mrs. Katherine McCrory, P. Eng., Project Manager; Mr. Hugh Loughborough, P. Eng., VP, Contract Administration and Risk Management; Mr. Sebastian Wojewoda, Project Coordinator; and Mr. Aaron Johnson, P. Eng., Account Manager, for their wonderful advice, technical support, and guidance throughout the entire procedure. Without their contribution and Dr. Haas's support, it would not have been possible to join the crew at Aecon Industrial and participate in their work.

I would like to gratefully acknowledge and thank my Undergraduate Research Assistant colleague, Maclean Gordon, for all his support, hard work, and great ideas throughout my research program. His excellent reputation, effort, and preplanning made many difficulties manageable. Without his assistance it would not have been possible to arrange and participate in site visits. I would also like to acknowledge the site crews for making us feel at home while we were on site, and I wish to thank Larry Taylor, Mark Couillard, and Dwayne Tsange for their insight, extra support, and valuable ideas associated with my research.

I would like to acknowledge my colleagues, Mr. Michael C. Gouett and Mr. Di Zhang, for giving me helpful advice and invaluable support and for sharing their experience. I would also like to gratefully acknowledge Mr. Saman Mohammadi for all his help, support, valuable advices, and great ideas through this journey, and I wish to thank all my friends and colleagues, who provided unconditional support in many ways throughout my studies.

My deepest appreciation goes to my parents, Shahram and Soussan, for their unconditional love, support, and understanding and for giving me the wings to fly, and also to my sister, Yasaman, for always being there for me and for being my best friend in the journey of life.

Last but not least, special thanks to my Lord for always encouraging me never to give up and for reminding me that all things are possible as long as we believe in ourselves and in Him.

*To my wonderful father, Shahram;
my compassionate mother, Soussan;
and my lovely sister, Yasaman*

Table of Contents

AUTHOR'S DECLARATION	ii
Abstract	iii
Acknowledgements	iv
Dedication	v
Table of Contents	vi
List of Figures	ix
List of Tables	xiii
Chapter 1 : Introduction.....	1
1.1 Background	1
1.2 Statement of Research	2
1.3 Scope and Objectives	3
1.4 Research Methodology.....	3
1.5 Structure of the Thesis.....	4
Chapter 2 : Literature Review	6
2.1 Construction as a Type of Production	6
2.2 Construction Productivity	7
2.2.1 Labour Productivity.....	10
2.2.2 Factors Affecting Labour Productivity.....	12
2.3 Methodologies for On-Site Productivity Improvement in Construction	14
2.3.1 On-site Productivity Improvement Methods	14
2.3.2 Approaches to Data Gathering For On-site Improvement Studies	15
2.4 Activity Analysis.....	20
2.4.1 Continuous Improvement Process	20
2.4.2 Introducing a Comprehensive Workface Assessment Method.....	20
2.4.3 Further Requirements	23
2.4.4 Summary	24
2.5 Estimation Theory and Applications	24
2.5.1 Estimation in Construction	25
2.6 Target Rate Theory and Applications	30
Chapter 3 : Validation of Activity Analysis	34

3.1 Background	34
3.2 Procedure of Implementing Activity Analysis for Continuous Improvement	36
3.2.1 Best Procedure for Introducing the Craft Workers to the Study	38
3.2.2 On-Site Responsibilities of the Observers.....	39
3.2.3 Conclusion.....	40
3.2.4 Implementing Recommendations More Efficiently	40
3.3 LB Project	41
3.3.1 Site Overview	41
3.3.2 Overall and Hourly Categories Analysis: First Site Visit.....	41
3.3.3 Trade Analysis.....	42
3.3.4 Positive and Negative Points Observed.....	45
3.3.5 Recommendations	47
3.4 LB Project: Second Cycle, Following Implementation.....	47
3.4.1 Site Overview II	47
3.4.2 Visible Site Changes and Corresponding Advantages	48
3.4.3 Overall and Hourly Category Analysis: Second Site Visit.....	50
3.4.4 Trade Analysis.....	51
3.5 Comparison of the First and Second Cycles for the LB Project.....	54
3.5.1 Same-Trade Activity Rate Comparison: LB (I, II).....	54
3.5.2 Trade Comparison Summary: LB (I, II).....	56
3.5.3 Overall Activity Rate Comparison, LB (I, II)	60
3.6 LB site summary	61
3.7 DN Project.....	63
3.7.1 Site Overview	63
3.7.2 Overall and Hourly Category Analysis: First Site Visit.....	63
3.7.3 Trade Analysis.....	64
3.7.4 Positive and Negative Observations	69
3.7.5 Recommendations	70
3.8 DN Project: Second Cycle, Following Implementation.....	70
3.8.1 Visible Site Changes and Corresponding Advantages	70
3.8.2 Overall and Hourly Category Analysis: Second Site Visit.....	72

3.9 Comparison of the First and Second Cycles for the DN Project	76
3.9.1 Same-Trade Activity Rate Comparison: DN (I, II)	76
3.9.2 Trade Comparison Summary: DN (I, II)	78
3.9.3 Overall Activity Rate Comparison: DN (I, II).....	81
3.10 DN Site Summary	82
3.11 HN Project.....	83
3.11.1 Site Overview	84
3.11.2 Overall and Hourly Category Analysis: First Site Visit	84
3.11.3 Trade Analysis.....	86
3.11.4 Positive and Negative Observations.....	89
3.11.5 Recommendations	90
3.12 Overview of Data Collection at the Three Sites.....	91
Chapter 4 : Target Rate Evaluation	94
4.1 Introduction to Data Analysis	94
4.2 Data Resources	96
4.3 Target Rate Models	98
4.3.1 Approaches to Setting Target Rates	98
4.3.2 Adaptive Neuro-Fuzzy Inference System.....	101
4.3.3 Experience Based Approaches to set Target Rate	116
Chapter 5 : Conclusions & Recommendations.....	128
5.1 Conclusions	128
5.2 Recommendations for future Research	129
References.....	130
Appendix 1: Sample Calculation.....	135

List of Figures

Figure 1: Linear Scale	28
Figure 2: Nonlinear Scale.....	29
Figure 3: Overall grade points for goal & control group before and after the study	32
Figure 4: Average percent direct work improvement of successive cycles compared to cycle 1	34
Figure 5: Activity Analysis sheet	35
Figure 6: Activity Analysis Procedure	37
Figure 7: Pie Chart showing overall activity rates, LB I.....	41
Figure 8: "Roller coaster" chart showing overall hourly activity rates, LB I.....	42
Figure 9: Pipefitter activity rates, LB I.....	43
Figure 10: Civil activity rates, LB I.....	44
Figure 11: Electrical activity rates, LB I	44
Figure 12: Operator activity rates, LB I	45
Figure 13: Pie chart showing overall activity rates, LB II.....	50
Figure 14: "Roller Coaster" chart showing hourly activity rates, LB II.....	50
Figure 15: Pipefitter activity rates, LB II	52
Figure 16: Civil activity rates, LB II	52
Figure 17: Electrical activity rates, LB II.....	53
Figure 18: Operator Activity Rates, LB II.....	53
Figure 19: Comparison of the pipefitter activity rates (LB I and II)	54
Figure 20: Comparison of the civil activity rates (LB I and II).....	54
Figure 21: Comparison of the electrician activity rates (LB I and II)	55
Figure 22: Comparison of the operator activity rates (LB I and II).....	55
Figure 23: Activity rates per trade, LB I	56
Figure 24: Activity rates per trade, LB II.....	56
Figure 25: Difference in activity rates by trade, LB (I, II)	57
Figure 26: Comparison of overall activities, LB (I, II)	60
Figure 27: Differences in the overall activity rate, LB (I, II)	60
Figure 28: Pie Chart showing overall activity rates, DN I	63
Figure 29: "Roller coaster" chart showing hourly activity rates, DN I	64
Figure 30: Pipefitter activity rates, DN I.....	66

Figure 31: Civil activity rates, DN I.....	66
Figure 32: Electrical activity rates, DN I.....	67
Figure 33: Operator activity rates, DN I.....	67
Figure 34: Boilermaker activity rates, DN I.....	68
Figure 35: Ironworker activity rates, DN I.....	68
Figure 36: Pie chart showing overall activity rates, DN II.....	72
Figure 37: "Roller coaster" chart showing hourly activity rates, DN II.....	72
Figure 38: Pipefitter activity rates, DN II.....	74
Figure 39: Civil activity rates, DN II.....	74
Figure 40: Electrical activity rates, DN II.....	75
Figure 41: Operator activity rates, DN II.....	75
Figure 42: Comparison of the pipefitter activity rates, (DN I and II).....	76
Figure 43: Comparison of the civil activity rates (DN I and II).....	76
Figure 44: Comparison of the electrician activity rates (DN I and II).....	77
Figure 45: Comparison of the operator activity rates (DN I and II).....	77
Figure 46: Activity rates per trade, DN I.....	78
Figure 47: Activity rates per trade, DN II.....	78
Figure 48: Differences in activity rates by trade, DN (I, II).....	79
Figure 49: Comparison between overall activities, DN (I, II).....	81
Figure 50: Differences in the overall activity rate, DN (I, II).....	81
Figure 51: Activity rate comparison between same and all conditions.....	83
Figure 52: Pie chart showing overall activity rates, HN.....	84
Figure 53: "Roller coaster" chart showing overall hourly activity rates, HN.....	86
Figure 54: Pipefitter activity rates, HN.....	88
Figure 55: Civil activity rates, HN.....	88
Figure 56: Operator activity rates, HN.....	89
Figure 57: Comparison of individual trade activities, LB I, DN I, HN.....	91
Figure 58: Combined average activity rates, LB I, DN I, HN.....	92
Figure 59: Comparison of activity rates for the overall average and for equal trades, LB I, DN I, HN	92
Figure 60: Difference between all and equal trades, LB I, DN I, HM.....	93

Figure 61: Data analysis Tasks and Models (Myatt, 2007)	95
Figure 62: Overall average of each activity category	97
Figure 63: Potential Functional Models for Activity Target Rates	99
Figure 64: Average normalized direct work rate for different trades	102
Figure 65 : Average normalized preparation work rate for different trades	103
Figure 66: Average normalized tools/equipment and material handling rates for different trades	104
Figure 67: Average normalized waiting and travel time rates for different trades	104
Figure 68: Average normalized personal work rate for different trades	105
Figure 69: Overall activity rates among different trades	105
Figure 70: The architecture of an ANFIS with two inputs and two rules. Squares represent adaptive nodes with adjustable parameter sets, whereas circles represent fixed nodes with fixed parameter sets.	107
Figure 71: Data set used for training the ANFIS	111
Figure 72: Architecture of the generated ANFIS	112
Figure 73: Membership functions before training the ANFIS a) Type of trade MFs, b) Weather condition MFs.....	113
Figure 74: Membership functions after training the ANFIS a) Type of trade MFs, b) Weather condition MFs.....	113
Figure 75: Observed and Predicted Direct Work Rate in Good and Bad weather condition	114
Figure 76: Pipefitter activity rates: all projects	116
Figure 77: Electrical activity rates: all projects	117
Figure 78: Operator activity rates: all projects	117
Figure 79: Civil activity rates: all projects	118
Figure 80: Ironworker activity rates: all projects	118
Figure 81: Boilermaker and millwright activity rates: all projects.....	119
Figure 82: Carpenter and Cement finisher activity rates: all projects	119
Figure 83: Target rates according to all three estimation methods.....	120
Figure 84: Comparison of the three target rate approaches.....	121
Figure 85: Target rates for pipefitters estimated by all three methods	122
Figure 86: Target rates for civil workers estimated by all three methods	122
Figure 87: Target rates for electricians estimated by all three methods	123

Figure 88: Target rates for operators estimated by all three methods	123
Figure 89: Target rates for carpenters estimated by all three methods.....	124
Figure 90: Target rates for cement finishers estimated by all three methods.....	124
Figure 91: Target rates for ironworkers estimated by all three methods.....	125
Figure 92: Target rates for boilermakers estimated by all three methods	125
Figure 93: Target rates for millwrights estimated by all three methods.....	126
Figure 94: Trade-specific average target rates	127

List of Tables

Table 1: Daily temperatures and trade head counts, LB I	42
Table 2: Total activity observations by trade, LB I.....	43
Table 3: Daily temperatures and trade head counts, LB II.....	51
Table 4: Total activity observations by trade, LB II.....	51
Table 5: Daily temperatures and trade head-counts, DN I	64
Table 6: Total activity observations by trade, DN I	65
Table 7: Daily temperatures and trade head counts, DN II	73
Table 8: Total activity observations by trade, DN II.....	73
Table 9: Daily temperatures and trade head counts, HN	86
Table 10: Total activity observations by trade, HN.....	87
Table 11: Overall activity percentages	96
Table 12: Standardizing factors affecting labourers' work on site.....	98
Table 13: Normalized direct work rate for three projects measured over 17 days.....	102

Chapter 1: Introduction

1.1 Background

Construction is known as a complex, but systematic organization that is currently one of the largest and most challenging industries. This sector has been facing numerous problems in recent years. Even 25 years ago, Tucker in 1986 stated that construction costs had risen at a rate 50 % higher than the inflation rate. The duration of projects has increased, with many overrunning their projected schedules. Claims and lawsuits have multiplied to such an extent that on some projects, only the attorneys have profited (Tucker, 1986). All of these issues represent indications of a decrease in productivity.

In his analysis of the meaning of 15 different terms, Fenske defines productivity as a tangible reality (Derwin, 1982). However, it is also true that productivity is the relationship between input and output. All productivity measurements are basically an attempt to measure the effectiveness of indicators such as management skills, workers, materials, equipment, tools, and working space that are employed at or in support of workplace activities in order to complete a building, plant, structure, or other fixed facility at the lowest possible cost (Oglesby, 1989).

Recent studies have revealed indicators that lead to low productivity in construction, such as the relative labour influence and cost, which greatly impacts the total project expenditure (Rojas & Aramvareekul, 2003; Zack et al., 2004; Orth & Jenkins, 2004). In the distant past, such as in the era when ancient Egypt and Greece were leaders with respect to construction projects, labour was truly inexpensive, and the solution to schedule and quality problems was to increase the workforce. Now, however, the combination of mass production and technological advances in material supply coupled with the increase in the cost of labour have made labour the most expensive and unpredictable resource that affects the success of a project. It is to note that labour costs generally make up 30 to 50% of overall project costs in the construction phase (Harmon& Cole, 2006).

Many techniques have been developed as attempts to improve productivity at a site and to reverse or at least mitigate the effect of any damage, including for example: work sampling, foreman delay surveys, craftsman questionnaires, and five-minute ratings. The latest tool that has been developed as a means of improving site productivity is Activity Analysis, which is defined as, “a continuous process of measuring and improving the amount of time that craft workers spend on actual construction. This measured time is referred to as tool time, wrench time, or direct work time” (Gouett et al., 2012). It should be mentioned that the use of Activity Analysis involves the designation of all labour tasks during a working day

according to seven defined categories: direct work, material handling, tools and equipment, travel, waiting, and personal. A major challenge is to identify an acceptable rate for each of these categories.

It is important for construction managers and the construction industry in general to set targets for all activity categories that do not attempt to increase the direct work rate beyond feasible levels by simultaneously attempting to minimize other activity categories. Experience shows that decreasing other activity categories beyond an acceptable level has a negative impact on the direct work rate (Thomas, 1995; Gouett et al., 2012). On the other hand, the effectiveness of an improvement program is reduced if the goals that must be achieved are not set. For example, it is impossible to have a direct work rate of 100 % and a personal activity rate of 0 % (Gouett et al., 2012). The goal is not to achieve unrealistic percentages; it is to increase the direct work rate and to effect a reasonable decrease in idle time through the removal of barriers. This thesis introduces a procedure and model for optimizing the direct work rate of labour based on Activity Analysis.

1.2 Statement of Research

Based on previous studies, it was concluded that labour productivity could not be predicted from the direct work rate (Thomas, 1992; Thomas, 1995). In reality, it is not possible to provide an effective and productive site that includes excessive rates of personal and/or travel time. For the construction industry, having a set target rate for all categories of activities performed by labour and for which they are responsible during working hours is a necessity. A target should be a realistic goal to aim for, and the ability to compare activity rates with target rates based on proper indicators is important for the prevention of both over-and under-evaluation. Experience shows that misjudgment leads to a lower direct work rate, which must be prevented. Comparing the direct work rate to the target rate enables the managerial level to be aware of the site condition and allows them to make effective decisions for improving it. When the target rate is defined, indicating influential factors, such as trade, complexity, and project stage, optimizes the decision-making process and allows the model to estimate the target rate more precisely, so that corrective decisions can be made at the appropriate time and excessive time is not spent on a category that is logically on target.

1.3 Scope and Objectives

The primary objective of this research was to define target rates and the goals that must be achieved throughout the entire process of improving on-site productivity, which in this research is specifically Activity Analysis.

The second objective was to discover which factors influence the direct work rate and other activity category rates and to determine the indicators that should be considered when the target rates are set.

The third objective was to develop a procedure and model for estimating the target rate for different categories and to evaluate the approximate number of projects that would be adequate for setting the target rates.

1.4 Research Methodology

The methodology for achieving the research objectives was as follows:

- Complete a detailed review of the literature that focuses on construction productivity, Activity Analysis as an on-site productivity improvement tool, estimation theory and applications, and strategies for setting target rates for different indicators in different sectors such as social, economic, and physical.
- Validate Activity Analysis tool for projects of different sizes (from relatively large to relatively small) with respect to two aspects: first, evaluating the activity level at the current stage of the project, and second, improving productivity continuously throughout the entire project.
- Develop a comprehensive process for estimating a target rate based on significant indicators for all activity categories. The new process was formulated using findings based on estimation theory and practice as well as on the published literature.
- Conduct three case studies. Two of three case study projects included three- to four-day visits, several weeks apart. All sites were visited by the author. This data-collection procedure was conducted to further the validation of Activity Analysis as a continuous productivity improvement tool, and for the author to develop insight into factors affecting direct work rate and productivity.
- Improve the process according to the lessons learned from the case studies.

- Consolidate all of the data available and validate the target rate model.
- Comment on the applicability of the process to other construction projects.
- Provide conclusions and recommendations regarding future research.

1.5 Structure of the Thesis

This thesis presents the research objectives, methodology, and findings in five chapters that cover background information about construction productivity; activity analysis in detail; estimation theory and applications; case studies and statistical validations; target theory and applications; and finally, conclusions and recommendations.

Chapter 1 discusses previous achievements with respect to productivity in the construction industry and provides details about methods of improving on-site productivity, such as Activity Analysis. It also clarifies the need for the construction industry to set target rates for different activity categories that labour performs during the day. The scope, objectives, and methodology to support the research goals have been presented.

Chapter 2 summarizes the background information necessary for building a solid knowledge and understanding of the research needs, including (1) an introduction to construction productivity; (2) definition, procedure, and required end goals of Activity Analysis; (3) estimation theory and application; and (4) definition of and theory about target rates in different sectors. The close relationship of Activity Analysis and the setting of the target rate for different activity categories is identified. To provide a better understanding of this relationship, a much more detailed literature review of factors that affect the work performance of labour is provided.

Chapter 3 presents the initial data collection and data analysis based on three sites visited by the author. This chapter includes the validation of Activity Analysis as well as the procedure for setting targets based on significant factors. A discussion of the significance of the results and the author's detailed field experience are also provided.

Chapter 4 discusses the general principles for setting target rates and presents the sources of data used in this research. The adequate number of projects for formulating a suitable target rate is defined, and a procedure and model which estimates target rates based on significant indicators are introduced.

Finally, Chapter 5 summarizes and presents the major conclusions and provides recommendations with respect to both improvements in the current procedure and suggestions for future research in this field.

Chapter 2: Literature Review

2.1 Construction as a Type of Production

Construction is a unique type of production that requires in-depth exploration and explanation. The term covers a wide range, from slow, certain, and simple, also known as stodgy, projects at one end to quick, uncertain, and complex, known as dynamic, projects at the other. The “One-of-a-kind nature of projects, on-site production, and complexity (i.e., temporary multi-organization and regularity intervention)” separates construction from other types of production (Koskela, 2002).

It is obvious that the individuality of a construction project is a relative measure, which could range from mass production of prefabricated housing on one end of the spectrum to a complicated and one-of-a-kind bridge structure on the other. “Site production” differentiates construction from manufacturers such as airplane building and shipbuilding, which strive to achieve a vision of repeatedly producing consumer products. In manufacturing, specialized facilities with appropriate technology and layout ensure the reliable flow of the product. With repetition, this network becomes manageable and is optimized to some extent. In contrast, construction deals with activities that are highly interrelated and complicated. On-site production relies on a primary design that involves a number of subassemblies with different specifications (Bertelsen, 2003). One of the major challenges associated with construction is the management of the subassemblies, which are constrained by the interaction and overlapping activities of different contractors, making it difficult to meet a fixed schedule.

Another major factor that differentiates construction and manufacturing processes is their lifecycle. In manufacturing, the life cycle of a product on the market is long enough to enable the development of related research capabilities. In construction, a product’s lifecycle is the relatively short duration of the project to its completion date, thus making it more difficult to justify research. The consequent lack of investment in research thus limits the development of innovations in construction process and technology and therefore threatens advances in this type of production in both local and global markets (Banik, 1999).

The combined effect of unique characteristics such as on-site, one-of-a-kind, and complex production is uncertainty. One of the factors that adds uncertainty to construction and could be considered unique is defined as rootedness-in-place. Factors such as the following make it difficult to determine precisely all aspects of a project prior to actual production (Howell):

1. Soil conditions that vary from one place to another
2. Different wind loads and seismic conditions that exist in different locations
3. Physical surroundings, both natural and artificial, that differ from area to another within the site
4. Differences in codes and regulations in different locales, which require alternative approaches

2.2 Construction Productivity

Construction projects are built for industry, business, individuals, and governmental organizations. In short, this includes much of what surrounds us, including plants, buildings, roads, housing, systems for supplying water and disposing of waste, and many other facilities that are required to keep our modern society viable (Oglesby, 1989). Construction is one of the largest industries in the world.

It has been the interest of researchers, engineers, owners, and contractors for decades to improve and maintain construction productivity at a variety of levels and for their own benefit. Estimation and goal setting for different sectors, as well as determining how best to achieve the goals without impacting other sectors have always been a challenge in this industry. An essential element for this research was to define productivity with respect to construction needs.

Productivity is a general term whose definition varies based on different points of view, and a single industry measurement is insufficient (Crawford & Vogl, 2006). Definitions range from industry-wide economic parameters to the measurement of crews and individuals. Each of these measures has its own unique purpose (Thomas, 1990).

In general, productivity is considered the relationship between input and output (Thomas & Mathews, 1986). “Inputs, measured in dollars, include labour, tools and equipment, and materials. Outputs are deliverables that contribute to the completion of the project, whether it is cubic meters of concrete placed, tons of steel erected, or length of pipe welded” (Gouett et al., 2012). The major goal is to decrease the input and increase the output to a satisfactory level. This goal requires an understanding of what, how, and how much each factor affects productivity. An important constraint for an examination of productivity is to classify the level of detail required for the research and for different construction operations.

For previous studies of construction productivity, researchers have devised a number of formulas based on where the productivity needs to be measured. Some of these definitions include the following:

- *Total Factor Productivity*

$$TFP = \frac{\textit{Total output}}{\$Labor + \$Materials + \$Equipment + \$Energy + \$Capital}$$

Total Factor Productivity (TFP) is an economic model that measures in terms of dollars, since the dollar is the only standard measure for both output and input (Thomas, 1990).

$$TFP = \frac{\text{Dollars of output}}{\text{Dollars of input}}$$

This model is useful for policy-making and evaluating the state of the economy, but it is not useful for contractors. It is inaccurate to apply this definition to a specific project or site because of the difficulties in predicting the input since it is influenced by different factors (Thomas, 1990).

- *Project-Specific Models*

Project-specific models could be used by the private sector for conceptual estimates related to individual projects. Output is defined as the number of units being completed. Input is defined as the dollars spent in order to complete a specific unit (Thomas, 1990).

$$\textit{Productivity} = \frac{\text{Output}}{\$Labor + \$Equipment + \$Materials}$$

As is clear, the metric of this formula is the unit per dollar. The goal is to maximize the productivity number because it indicates a greater degree of physical output gained from the same amount of money. The methods of improving this number are to reduce the dollar value of the labour, equipment, and materials or to increase the physical output. Based on research done 22 years ago, from one project to the next, little opportunity existed for significant decrease in equipment and material costs. Hence, a good approach was to address the labour cost and attempt either to decrease the labour cost or to obtain greater physical output for the same labour cost (Thomas, 1990).

- *Activity-Oriented Models*

An activity-oriented model is used primarily by contractors and defines productivity more narrowly than in the above definitions. In this definition, difference in equipment and material costs between projects become negligible, and the only constraint that remains important is the number of hours of work performed by labour on site, which is used to indicate input. Output remains the physical output, in units such as cubic yards, tons, or square feet, which generate the denominator. Since a variety of factors affect labour and labour cost, this model does not include the cost of the labour but instead evaluates the number

of units being completed in a work-hour (Thomas, 1990). This definition is hence termed “Labour Productivity.”

$$\text{Labor Productivity} = \frac{\text{labor work hours}}{\text{Output}}$$

In this formula, the goal is to achieve a lower value because it indicates more physical output with the same number of work hours. The benefit of choosing labour work hours rather than labour cost is the result of the variation in labour cost, which differs based on location, economics, union versus non-union, and other factors.

- *Productivity Factor*

The definitions and formulas differentiate between productivity and the productivity factor, which is expressed as follows (McDonald & Zack, 2004):

$$\text{Productivity Factor} = \frac{\text{Actual Productivity}}{\text{Baseline or Planned Productivity}}$$

This equation indicates an acceptable comparison between the actual productivity and what has been planned. The goal in the above formula is to maximize the productivity factor. A value of more than one is satisfactory, because the actual amount of the output that has been accomplished is greater than what was estimated.

Of all the factors, the major one that affects productivity and that could be monitored and influenced is labour direct work, or physical output. Another way to look at this definition is as follows:

$$\text{Productivity Factor} = \frac{\frac{\text{Actual work hours}}{\text{Actual output}}}{\frac{\text{Estimated work hours}}{\text{Estimated output}}}$$

If the estimated output equals the actual output, then work hours could be compared and the goal will be a reasonable minimization of the actual number of work hours. A lower value means fewer actual hours spent than were estimated. As defined above, an acceptable productivity factor appears to be less than one. If this value becomes greater than one, contractors and the managerial level become concerned, and it might also lead to issues with respect to cost and schedule.

2.2.1 Labour Productivity

Many factors affect construction productivity, but it can be argued that the major ones appear to be type, scope, layout, and complexity. In the construction field, changing or improving such characteristics is difficult and sometimes impossible. One factor that is more amenable to monitoring, comparing, and improving is labour work. Labour productivity, or the output per hour worked, is considered one of the best indicators of production efficiency. Higher productivity levels usually translate into superior profitability. A sustainable improvement in labour productivity is also associated with economic progress because it generates noninflationary increases in salaries and wages (Rojas, 2003).

2.2.1.1 Labour Productivity Trend

An extensive collection of publications have stated that labour productivity has declined for the past several decades, especially in North America; this topic should therefore be carefully reexamined.

The impact of labour in construction can be more effectively illustrated through the use of an example from Tucker's research on labour productivity in 1986. A large petrochemical construction project was reported on by a major oil company located in the United Kingdom, with 2,000 tradesmen working 54 hours a week. A schedule was prepared for 31 months of construction, which is theoretically 7,500,000 work hours. A post-project analysis showed that about 1,700,000 work hours were lost to holidays, strikes, absenteeism, and late starts and early quits. Another 1,200,000 work hours were lost to weather, legitimate union activities, and other miscellaneous problems. Thus, of the 7,500,000 theoretical work hours, only 4,600,000 hours were even available for work on the job. In addition, about 1,000,000 work hours were spent on indirect work, such as handling material, cleaning up the site, maintaining equipment, and building temporary scaffolding and facilities. Another 300,000 work hours were spent in rework and in the correction of errors. The net result was that only 3,000,000 work hours were available for direct work, which is 50 % of the theoretical work hours. However, in reality only 1,500,000 hours were spent on direct work, which is only 20 % of the theoretical work hours (Tucker, 1986). This problem may be more severe in developed countries because of the higher labour wages, but large projects in third world countries likely have the same problem, with the difference being a lower labour cost. Both cases involve a negative result.

Declining productivity, which implies that management and workers are performing worse and worse over time reflect negatively on the image of the industry and have significant economic effects. Over

time, declining productivity will result in some combination of declining real wages, increasing real construction costs, declining profits, or lower quality (Rojas, 2003).

Based on previous studies, labour productivity in construction has declined since the 1960s. Reports show that real output per unit hour in the US construction declined by an annual rate of 2.4 % to 2.8 % between 1968 and 1980 (Allen, 1985; BRT, 1983; Stokes, 1981). More recent research using macroeconomic data shows that labour productivity has continued to decline at an annual compound rate of 0.48 % (Teicholtz, 2001). On the other hand, studies based on microeconomic productivity data have reached different conclusions. Goodrum in 2009 reported that, for 200 sampled activities, labour productivity has improved at an annual rate of 1.2 % from 1976 to 1988 (Dai, 2009).

As with other experts, Rojas and Aramvareekul (2003) measured productivity as output (constant dollars) per hour of work. Allmon et al. (2000) measured productivity in terms of unit labour cost, output, and direct work rates at the individual work task level. Based on the measurement of cost and physical output per unit hour of work, both studies generally found increasing construction productivity over the past few decades. The authors argue that the combined national data available for estimating trends in productivity are very poor and unreliable. The Bureau of Labour Statistics in United States does not report productivity trends in the construction industry, due to unreliable data. Rojas and Aramvareekul suggest that the mix of construction activities may be responsible for the indication of any sort of productivity decline. Individuals have been discouraged from using labour productivity data at the macro level to argue that the construction industry is performing worse and worse over time. Researchers have contended that no direct relationship exists between construction industry performance over time and labour productivity.

A study of past and present trends in labour productivity proves that it is necessary for the construction industry to develop accurate labour productivity data in order to create the feedback loop required for analyzing the effects of different industry-wide initiatives. Improvements are usually achieved through trial and error, and this procedure requires coverage of a wide range of factors that may vary over time, such as price indices and labour wages. Labour productivity must also be evaluated consistently over decades so that comprehensive trends over time can be shown and compared. One solution could be a reliable metric that evaluates outcome.

It has been argued that it is important for the construction industry to achieve continuous improvements in labour productivity and to broaden and accelerate such gains in an increasingly global marketplace. Last

but not least, by setting achievable goals, the construction industry also needs to understand with an adequate level of accuracy the magnitude of labour productivity, expectations, and the range of improvement (Rojas, 2003).

2.2.2 Factors Affecting Labour Productivity

On construction projects, numerous circumstances may lead to a decline in productivity. Based on recent publications, a list has been compiled that covers most factors that affect construction productivity and that may also have an impact on labour productivity as well. The factors that lead to cost and/or loss of time need to be studied in order to identify the source of the problem as well as its influence on other aspects of the project due to the interrelated nature of construction procedures and the impact on labour productivity. These factors include the following (Zack, et al. 2004):

<ul style="list-style-type: none"> • Absenteeism and the missing man syndrome • Acceleration (direct or constructive) • Adverse or unusually severe weather • Availability of skilled labour • Changes, ripple impact, cumulative impact of multiple changes, and rework • Competition of craft labour • Craft turnover • Crowding of labour or stacking of trades • Defective engineering, engineering recycle and/or rework 	<ul style="list-style-type: none"> • Failure to coordinate trade contractors, subcontractors, and/or vendors • Fatigue • Labour relations and labour management tensions • Learning curve • Material, tools, and equipment shortages • Over-manning • Poor morale of craft labour • Out-of-sequence work • Dilution of supervision 	<ul style="list-style-type: none"> • Project management factors, such as incorrect mix of labour crews, improperly planned and implemented project initiation procedures, poor site layout • Schedule compression impacts on productivity • Untimely approvals or responses • Site or work area access restrictions • Site conditions, such as physical , logistical, legal, and environmental conditions • Rework and errors
--	---	---

Once the primary productivity loss has been detected for a specific project, the baseline estimate must be reconfirmed by the taking into account of all major parameters associated with the project. These parameters, which differ from one project to another, include the type of contract, the scope of work, the stage of work, and the complexity of the project. For an identified productivity loss, it is important not to compare the field productivity with a baseline that has been developed without consideration of the essential project characteristics (Zack et al., 2004).

Another factor that has not been covered above and should be considered is the classification of the construction industry itself into four distinguishable industries: residential, commercial, industrial, and heavy construction. This classification is important not only because of different levels of magnitude of production in these sectors but also because of the essential differences among these sectors. Residential and commercial construction is labour intensive compared to industrial and heavy construction, which tends to be capital intensive. Residential and commercial construction projects are therefore expected to have lower productivity than industrial and heavy construction because the substitution of labour with capital produces a higher productivity value.

Output mix is another labour productivity term, which indicates an evaluation of an average productivity value for each of the sectors. The labour productivity factor evaluated for the entire construction industry needs to be an average weighted for different sectors based on their proportion in the industry. Changes in the output mix affect labour productivity. The difference between the actual decline in productivity and changes caused by the output mix could thus be identified and differentiated (Rojas, 2003).

Improvement in productivity through jobsite efforts may reduce the project costs by up to 30% (Kellogg et al., 1981). Craft workers as the major players, who execute construction process and activities, have a significant influence on labour productivity (Maloney, 1983). It is important to know what craft workers need and what affects their performance in order to achieve any improvement in productivity (Oglesby et al., 1989). Unfortunately, input from craft workers and their perception of the issues that influence their daily productivity have rarely been sought, either because it takes time from tasks that must be performed or because it is considered an infringement on management's right to control the work. However, craft workers are certainly in an ideal position to know where and how much of site productivity is lost or gained at the workplace. A better understanding of the factors that influence labour productivity from the workforce perspective could enable site management teams to more effectively allocate their limited

resources, provide craft workers with better support, increase the motivation of the craft workers, and enhance their commitment to productivity improvement (Dai, 2009).

2.3 Methodologies for On-Site Productivity Improvement in Construction

2.3.1 On-site Productivity Improvement Methods

Three important mechanisms that lead to observed productivity increases over the course of a project are the learning curve, the Hawthorne effect, and direct improvements to the construction process (Gouett et al., 2012). The learning curve is a typical productivity measure that is used at the beginning of any project or major work task. It indicates the familiarity of workers with project activities as the project work proceeds. The workers must become familiar with the site and its layout (such as washroom locations, material and equipment locations, and the pathways towards their jobs) and with project requirements (such as the level of quality required, the production output needed in order to meet the schedule requirements). Thomas et al. (1986) showed that as project tasks move forward, the craft workers become more familiar with their jobs and therefore are more efficient and profitable. The learning curve might also be measured later on during the project if the work is suspended or the crew is demobilized and remobilized. Since this curve is not integrated with a sufficient number of the factors which affect labour work on site, thereby the identification of any site productivity improvement due to the learning curve is limited.

The Hawthorne effect states that if the workers are conscious of being observed, the productivity rate may increase. This effect was first found based on the National Research Council experiments at Western Electric's Hawthorne plant in Cicero, Illinois, in 1924, whose objective was to determine whether better lighting enhances productivity. The results showed that better lighting does improve productivity. The primary experiments led to additional ones in the late 1920s, which measured the effect of changes in working arrangements (i.e., work hours and breaks) upon productivity. Output did increase as a result of the changes implemented. Based on the work of George Pennock (1924-1927), who was one of the engineers involved in the experiments at that time; an interesting result later demonstrated, was that the output increased regardless of any changes made. His reports showed that the output increased even after the work condition had been returned to the baseline condition. What has been concluded from this research is that the attendance of an observer whose role is to measure a worker's productivity will cause an impact on the worker's performance. The impact could be either negative or positive. Also based on

experiments conducted in the late 1920s, it has been shown that after an observer leaves the work place, productivity declines, even to the point of workers being fired for a deterioration in performance. No final result has yet demonstrated an increase in productivity because of the attendance of an observer who tracks the work trend in the actual workplace. This effect is hence artificial and temporary and is not the best method for improving construction productivity.

In contrast with the productivity improvement methods mentioned above, direct improvement leads to more efficient and longer-lasting improvements (Gouett et al., 2012). Such improvements persist after the observer leaves the site. The focus of the research presented in this thesis was therefore on direct site productivity improvement methods, and the first step toward achieving the research goal was to determine how to gather data to improve on-site operations that are already underway. Henry (1991) argues that management should have a current measure of productivity if they are to make timely decisions. Factors that affect construction productivity and that ultimately affect labour productivity are discussed in the previous section. Of all of the parameters mentioned, labour, equipment, material, time, and cost are the factors that can be managed by the managerial level. Material is usually purchased by the administrative staff, and the quantity is certain and dependent on the design specifications and on the job task that needs to be performed. Supply and material are therefore limited, and this limitation reduces the number of factors that the managerial level can influence. Labour is statistically one of the most expensive resources used in construction and is the only one that can be easily controlled in the field. A satisfying assessment to monitor and evaluate the managerial level in their application of available resources, material, and particularly labour, for a job in hand must be an on-site measure and gathering data on the work site could fulfill this need.

2.3.2 Approaches to Data Gathering For On-site Improvement Studies

A number of methods and approaches have been established in order to gather data for on-site improvement studies that focus on the labour work flow on a work site: questionnaires, interviews, activity sampling, and recording present workplace practices (Oglesby, 1989). Each of these methods has advantages and disadvantages and focuses on specific parameters. The following is a quick review of each of these approaches.

- *Questionnaires and Interviews for Craftsmen or Foremen*

One effective approach to gathering data for site improvement in the construction industry, which has been used since the mid-1960s, is to ask the people who are involved on the site on a daily basis because

they are knowledgeable, know what is going on, and have excellent ideas (Oglesby, 1989). Experience has shown that workers and foremen often have a better perception and greater knowledge of site conditions than higher management. Interviews are also used primarily to add value and detail to the questionnaires, but since they are always conducted during work hours, their cost is highly visible, and employers avoid conducting them (Oglesby, 1989). If questionnaires are adequately prepared, they can have the following benefits:

1. Raise questions that the managerial level may consider important or critical either to solve or to answer
2. Identify sources of inefficiencies and delays and possible suggestions for decreasing them
3. Provide a job-to-job comparison of methods, materials, management, and working conditions
4. Identify barriers, such as some policies and resources
5. Provide a valid and honest report that could be compared to management reports in order to check accuracy and identify the procedure and issues in the case of differences (Oglesby, 1989)

Another approach that is more detailed than questionnaires is foremen delay surveys. The primary focus of this approach is to identify problems that are not within the foremen's responsibilities or control. The concept is to determine the ratio of the hours lost for a variety of reasons to the number of workers involved in the delay multiplied by the entire number of workers who have been observed. The resulting percentage is a good approach for determining corrective actions (Oglesby, 1989). The advantages of this type of survey are as follows (Tucker, 1982):

1. A fast and relatively easy procedure
2. A way to reduce delay
3. An effective tool for projects that involve serious productivity issues
4. A way to identify and quantify obvious problems
5. An excellent communication path between foremen and higher managerial levels

The following are the disadvantages of both the questionnaires and the surveys (Oglesby, 1989);

1. There is a lot of paper work
2. They might cause serious friction within the crew and/or between the crew and the foremen
3. Unsatisfactory reports from a foreman might cause fear and lead to the idea that higher management might consider him responsible for the problems
4. They are time consuming

- *Work/Activity Sampling*

Work sampling measures how time is utilized by the labour force (Thomas et al., 1984). A suitable definition of work sampling is “An application of random sampling techniques to the study of work activities so that the proportions of time devoted to different elements of work can be estimated with a given degree of statistical validity” (American Institute of Industrial Engineers, 1989). Work sampling is designed to determine how active the crew members are during the operation under observation (Liou & Borcharding, 1986).

The activities performed by the craft workers must be classified according to specific and well-defined categories. From 1972 to 1984, only two categories were used: direct work and non-productive work. The minimum sample size required was 800. From 1986 to the present, the categories of activities performed by craft workers have increased. In one company’s system, seven categories are used: direct work, tools & equipment, travel, transport, instruction, personal time, and delay. For ease of analysis, these categories are often combined into three major groups: direct work, supportive work, and idle time. It should be mentioned that the three major groups originated from the work in the 1970s and 1980s of researchers such as Henry W. Parker and Clarkson H. Oglesby. The minimum sample size required was increased to 2000 when projects grew larger, with crew sizes greater than 1000 (Gong, Borcharding, & Caldas, 2008). In practice, the categories may be defined by the contractor who is in charge of implementing the activity sampling on the construction site.

This approach provides timely information to management so that they can determine whether corrective action or detailed study is needed in order to achieve a higher degree of efficiency, based on increasing the direct work rate and decreasing delay (Liou & Borcharding, 1986). The fundamentals of activity sampling can be summarized in three points (Liou & Borcharding, 1986):

1. Trends in the amount of crew time spent on direct work during work hours is important to the managerial level in terms of labour utilization
2. Problem areas that cause work delays can be identified and managerial attention directed to the areas where it is most needed. The next step is to investigate the causes of the delays that have occurred, which could include insufficient information flow, inadequate material and/or equipment supply, poor engineering, extensive crew interference, inadequate construction tolerances, or low morale

3. A baseline and/or goal measure can be set up in order to determine improvement and to serve as a challenge for management and the workforce

The three major approaches to activity sampling are as follows (Oglesby, 1989):

1. Field Ratings, for which the activities performed by craft workers are divided into only two categories: working and not working
2. Productivity Ratings, for which the activities are recorded in more detail and are presented more precisely by categorizing them into narrower definitions, such as direct work, contributory work, and unuseful work
3. Five-Minute Ratings, for which the crew activities are recorded in shorter intervals

Work sampling is an extremely useful device for providing an overall survey of a specific operation and is also an effective way to establish a benchmark for the managerial level as well as to determine the factors that affect the labour work on the site (Liou & Borcharding, 1986). This method is easy to implement and less costly than other methods; it can be performed for a different levels of detail, ranging from a specific operation to an entire project; and it is applicable for projects of all types and sizes. Unlike questionnaires and interviews which were previously discussed, activity sampling does not require the time or involvement of foremen or craft workers.

A major difficulty with the work sampling is that direct work does not necessarily correlate with unit rate productivity (Thomas, 1991). For example, a craft worker may spend 3 hours welding a pipe, while another worker may take only 2 hours to weld the same pipe. This discrepancy could be the result of the skill level of the workers being observed, the work methods, and/or the types of tools and equipment used (Gong, Borcharding, & Caldas, 2008).

Of course, good on-site productivity cannot be achieved when labour spends excessive time waiting or engaged in personal activities. Another issue that may arise during work sampling occurs when the person who is tracking the craft workers on site makes them uneasy while tracking them, or does not understand the definition of the categories so that the crew is tracked differently from what is expected, or is unable to take quick snapshots on site and misses the craft workers performing activities that are common mistakes, which could be improved through more practice and experience.

- *Recordings as an Approach to Improving Workface Practices*

Henry W. Parker (1972) states that the techniques explained above are used for an immediate evaluation of an operation or a task. Sometimes indicators, such as concern on the part of the managerial level, lead to a more in-depth evaluation of an operation or a task. It has been reported that recording methods such as stopwatch studies, observation techniques, and time-lapse motion pictures will lead to job improvement, work simplification, and cost reduction. The steps involved in determining the use of these recording methods are as follows (Parker, 1972):

1. How the job is currently being completed needs to be recorded in full detail
2. The objective of the job needs to be completely understood, and the data needs to be analyzed based on the objective. The flow of the crew and materials, excessive time required to perform specific tasks, and activities that are not required but that take place must all be completely monitored
3. The development of new methods that lead to a more productive site is necessary at this stage in order to correct problems such as difficult maneuvering of craft workers, difficulty accessing material, and excessive time spent on tasks
4. The specific method must be chosen and implemented

The documentation being recorded, also referred to as the job record, can take different forms based on the application and specific purposes. It could be targeted at factors ranging from overall cost to site productivity and labour organization, and could take the form of descriptions or photographs of the job. A detailed study that covers site layout, labour, equipment, tools, and material handling should start with the big picture and then gradually focus on the smaller sections of a task or an operation. If the small detail does not meet the big-picture goals of the entire project, time is being wasted on irrelevant details. For example, without knowledge of how a specific task is performed, it is impossible to consider how the labour work flows and which approaches can be implemented to improve that specific task (Parker, 1972).

2.4 Activity Analysis

2.4.1 Continuous Improvement Process

Based on historical studies of construction operation improvement methods, in 1989, Oglesby, Parker, and Howell made an outline of a five-step procedure, as follows (Oglesby, et al., 1989):

1. Gathering sufficient data
2. Analyzing that data
3. Identifying the problem
4. Develop a new or revised method
5. Implementing the new method

In 2004, Hans Picard employed the same approach while discussing work sampling, with the difference that he combined the steps established by Oglesby et al. and eliminated the fifth step, which is critical for activity sampling.

A relatively important step not mentioned in either of the above approaches is that after implementing the changes on site, it is critical to reevaluate the site to ensure that the changes have led to improvements. Although Jenkins and Orth (2003) studied the monitoring and validating of work sampling improvements by implementing work sampling studies in regular time intervals (Gouett et al., 2012), Activity Analysis has introduced a more comprehensive method than those previously discussed.

2.4.2 Introducing a Comprehensive Workforce Assessment Method

Activity Analysis is a guide produced by the Construction Industry Institute, Research Team 252-2a in the summer of 2010, which may be the most comprehensive method established for measuring the direct work rate and continually improving it while the project is in progress. "Activity analysis is defined as a continuous process of measuring and improving the amount of time that craft workers spend on actual construction. This measure is referred to as tool time, wrench time, or direct work time" (Gouett et al., 2012).

In other words, Activity Analysis establishes a cyclical approach to the identification of on-site problems that inhibit productivity, to the proposal of solutions to these problems, and to the measurement of the improvement in the direct work rates. The major goal is to reduce activities that do not actively advance the finished product, and thereby to increase the direct work rate (Gouett et al., 2012).

The combination of this updated workplace assessment method with a continual improvement process makes Activity Analysis superior to work sampling (Gouett et al., 2012). Activity Analysis is a five-step approach, as follows:

1. Plan Study: This step includes defining the objectives and scope, as well as determining other relevant details, such as the population, activity categories, and roots and times.
2. Sample Activity: A representative data sample is determined. Each discrete data sample or observation is categorized as direct work, preparatory work, tools and equipment, material handling, waiting, personal, or travel.
3. Analyze Data: Once the data have been collected, they are tabulated and analyzed in several different ways in order to determine which of the activities are beyond the acceptable range. This step also identifies the obstacles that lead to decreases in productivity. It should be mentioned that each category is defined as the ratio of the number of categories observed in a specific hour to the total observation for that particular hour.
4. Plan Improvements: After the sources of unacceptable variances are identified, several potential solutions for improving productivity could be considered. The recommendations need to be based on consideration of factors such as feasibility, logistics, and cost.
5. Implement Improvements: In the final step, the improvements selected in the planning stage are implemented in order to increase the direct work rate.

The major factor that distinguishes Activity Analysis from previous construction operation improvement methods is the continuous process that connects the first step to the fifth step. The following are the benefits of this approach:

1. To make sure that, after the implementation of the recommendations/changes, the direct work has improved.
2. The initial set of data produces a baseline and datum so that all cycles have a common basis of comparison. The record of results produced by the entire study thus clearly indicates improvement between cycles and provides a good database for the comparison of similar projects at similar stages.

In general, Activity Analysis is an effective method of identifying an improvement trend and of enabling a comparison during the progress of a project, but Activity Analysis must be implemented correctly.

At the big-picture level, Activity Analysis is similar to continuous observation studies and it has the following advantages (Gouett et al., 2012):

1. Ability to canvas an entire construction site
2. Lack of disruption of the work activities of craft workers or foremen
3. Greater likelihood of craft worker acceptance than with continuous observation
4. Desired level of accuracy enabled by statistically reliable techniques
5. Identification of specific areas for improvement

Another benefit of Activity Analysis that is worth mentioning is the finding of Michael C. Gouett (2010) while working on Activity Analysis. He pointed out the importance of the minimum sample size. Before the field trials, the minimum sample size was determined according to a binomial distribution equation that had been verified by several researchers. His research procedure was based on his theory that since more than two categories exist, multinomial distribution was the key, and his studies also led him to confirm his theory. At this stage of the research, the required minimum sample size increased, so that a site of 110 workers required 384 observations per hour. Because this number was almost impossible to achieve, the actual number of observations was then decreased, which only increased the error. Gouett then evaluated a method that determined the maximum number of observations for the worst case. The outcome was based on Thompson's (1987) work. This approach indicates that with a confidence level of 95 % and an error of 5 %, which are acceptable levels for the construction industry, regardless of the population size, 510 samples is adequate for each observation period (Gouett et al., 2012).

The disadvantages of activity analysis include the following:

1. Less efficient on sites where craft workers are spaced far apart
2. Observations need to adhere to stringent levels of accuracy and consistency
3. Potential for individuals to behave differently

The *Guide to Activity Analysis* report and Gouett (Gouett et al., 2012) validate this method by providing data related to the percentages of direct work improvement from several projects and companies. These data were compiled and analyzed according to the cycle. Based on what has been recorded, cycle 2 results showed an average of a 16.89 % higher direct work rate than that for cycle 1. The cycle 3 direct work rate was significantly higher (17.81 %) than the cycle 1 rate. Compared to cycle 1, cycle 4 had a direct work rate that had increased by an average of 14.65 % (Gouett et al., 2012).

2.4.3 Further Requirements

Setting Targets

One of the requirements for increasing the success of Activity Analysis as a continuous productivity improvement process is the setting of goals. Goal setting has two major benefits:

1. Setting goals prevents time being spent achieving levels of improvement that are infeasible or illogical.
2. Setting goals enables the improvement process to proceed efficiently so that it leads to further improvements and also prevents loss of effectiveness.

It has been argued that management should set targets based on the first cycle of the process. The rates need to be ambitious yet realistic. The purpose of Activity Analysis is not to achieve an impossible direct work rate of 100 % and a personal time rate of 0 %, but rather, it is to reduce or remove the barriers to achieving a higher direct work rate and less personal or wasteful activity.

During the evaluation of target rates, several factors that affect productivity and that were previously discussed must be considered, including but not limited to type of trade, project type, stage of the project, and weather. During each cycle of Activity Analysis all of these factors must be reviewed and revised if necessary. The following discussion of trade and stage of the project is presented as an example of how the above factors influence the direct work rate.

Based on a two-year case study and data gathering conducted by Oglesby in 1989, it was concluded that the direct work rate varies between trades. A typical direct work rate for pipefitters, electricians, and riggers could be as relatively low as 27 % to 28 %, compared to those of painters, labourers, and teamsters which are 42 % to 46 % (Oglesby, 1989). It could be argued that the complexity of the job, the location, and the number of crew involved affect this percentage for different trades. It is therefore inaccurate to set one target rate for both pipefitters and labourers, for example, because pipefitting work is more complicated and does not reflect the high direct work rate that is appropriate for labourers, and from the perspective of the labourers, whose work is less complex, the target rate suitable for pipefitters would be below what could possibly be achieved during a day.

In the early stages of a project, especially if it is a Greenfield construction project, the direct work rate is potentially very high because there are fewer barriers, and the site is more open for operation. In regular site conditions, operations such as excavation and scaffolding are therefore faster and can be

accomplished more easily. Targets are thus set at higher values than in the next stages of a construction project, which can be referred to as Brownfield, when the number of barriers increases; when it may be harder to maneuver; and when labourers are mostly replaced by electricians and pipefitters, who require more planning. For this reason, consideration must be given to the stage of a project when target rates are set (Gouett et al., 2012).

Although setting target rates for different activity categories is essential for Activity Analysis because it provides project goals for all personnel involved, it is not an easy task in view of the many changes in project characteristics that occur while the project is in progress and in view of all the factors that must be taken into account during the tracking and analyzing (Gouett et al., 2012).

Despite these advantages however there is very little information available on target rates, and nothing in the archival literature based on how to set them.

2.4.4 Summary

In conclusion, three major points that define Activity Analysis and identify this method as a more comprehensive method than work sampling have been discussed:

1. Activity Analysis includes significantly more detailed observations than other methods. Observations are typically broken down into seven or more categories: direct work, preparatory work, tools and equipment, material handling, waiting, travel, and personal. These categories are monitored for each of the crafts on a jobsite.
2. Activity Analysis provides more detailed results than other methods. The practice of conducting detailed observations during every working hour of the day and of separating them out by craft provides an enhanced descriptive assessment of how effectively craft workers' time is being utilized.
3. Activity Analysis is a continuous improvement process. Activity analysis relies on a continuous process of improvement through observation, identification of areas for the implementation of improvements, and reassessment (Gouett et al., 2012).

2.5 Estimation Theory and Applications

Estimation theory in construction will play an important role in setting target rates for Activity Analysis. It helps to understand the impact and interdependency of key project factors.

To estimate is, “To form a rough judgment regarding the value, size, weight, degree, extent, and quantity of; to rate by a rough calculation; to fix a worth of; compute or calculate approximately; to reckon” (Bledsoe, 1992). The approach to the estimating process varies depending on the point of view, the experience of the individual, the employer, and the work culture in which they work (Westney, 1997).

Types of estimation can be classified as follows (Westney, 1997):

1. How the estimate will be used
2. The type, quality, and amount of information available for preparing the estimate
3. The range of accuracy desired
4. The calculation technique used to prepare the estimate
5. The time allotted to produce the estimate
6. The method of input in order to obtain the desired output (computer, manual forms) with respect to preparing the estimate
7. The phase of the project (feasibility, appropriation, and construction) related to the estimate
8. The perspective of the preparer (owner, contractor, insurance company, etc.)

2.5.1 Estimation in Construction

In construction, from concept to completion of a project, cost estimation plays a key role in the decision-making process (Ahuja & Campbell, 1988). Six primary aspects of that role are as follows (Westney, 1997):

1. Provides an assessment of capital cost for a specific piece of work or for the overall project
2. Forms a foundation for planning and control by identifying the scope of work and the relevant estimated cost
3. Delivers basic information from the project such as hours, resources, tasks, and durations, information required for the preparation of the schedule; also states resource requirements such as labour, material, and construction equipment
4. Provides the financial input required to prepare a cash flow curve, which is defined as the schedule of payments that an owner has to make over a time period in order to build a typical project and which depends to a great extent on the type of contract
5. Offers a stimulus for assessing productivity and risks

6. Ties together within a single document the relevant project information, such as idea generation, team participation, clarity, and buy-in and leads to a much faster procedure for a variety of evaluations

2.5.1.1 Approaches to Cost Estimation

Cost estimation, which is usually referred to in construction as just “estimation”, covers a very wide range of construction evaluation perceptions, and many factors affect different aspects of this process. Powerful assessment models are therefore required. Therefore, cost estimation could be the best indicator for overviewing different estimation theories and their applicability (Westney, 1997).

The origin of all estimating techniques is an estimating algorithm or formula. The aim is to transform technical and programmatic information about a project into the desired output through the use of a predefined algorithm. It should be mentioned that the formulas are defined in terms of cost estimation. A very simple form of cost-estimating algorithms, which are referred to as cost-estimating relations (CER) appears as follows:

$$Cost\ resource = factor \times parameter$$

where *Cost resource* is defined as dollars (total, labour, material, etc.) or as time (labour hours, equipment rental hours, etc.), *Factor* measures the resource/unit of measure (man hours/ft² of pipe), and *parameter* is defined as the quantity of the estimated unit item (Westney, 1997).

From a mathematical point of view, CERs are stochastic, deterministic, or a combination of both. The stochastic point of view is referred to as parameter estimating in cost assessment and is based on hypothetical cost relationships and statistical analysis. In parameter estimating, the evaluation is based on measures other than the units of the item. The deterministic point of view is known as detail unit cost or line-item estimating and is based on specific and definitive cost relationships (Westney, 1997). As an example, to evaluate the cost of a concrete foundation that will support a large pump, the simplistic approach to differentiating these two definitions is as follows (Westney, 1997):

$$\begin{aligned} Parametric\ estimating: \$\ of\ concrete &= \$5\ concrete / \$100\ of\ pump\ cost \times \$120,000\ pump\ cost \\ &= \$6,000 \end{aligned}$$

$$\begin{aligned} Detail\ unit\ cost\ estimating: \$\ of\ concrete &= \$500/m^3 \times 12m^3 \\ &= \$6,000 \end{aligned}$$

It is worth mentioning that with both methods, a number of adjustments are made throughout the steps in the estimate in order to ensure that the final outcome covers all the criteria identified as the basis of the estimate (Westney, 1997).

Hendrickson (2008) has looked at big-picture approaches to construction cost estimation without any bias or preference for one method over others and has defined four distinct categories of cost estimation:

- *Production Function*

In microeconomics, this approach is defined as “the relationship between the output of a process and the necessary resource.” In construction, it may be expressed as the volume of construction (output) and various production factors such as labour, equipment, and material (input). For instance Q as output could be a function subject to several input factors $x_1, x_2 \dots x_n$, based on mathematical and/or statistical methods. An example of a production function is the relationship between the size of the building (ft²) and the input labour (labour hours/ ft²) (Hendrickson, 2008).

- *Empirical Cost Interface*

This method, which requires statistical inference, relates the output to several important characteristics of the system so that the best parameter values in an assumed cost function can be evaluated. It should be mentioned that with this method, regression analysis is compulsory.

For both of these categories, economies and diseconomies of scale are typical. Scale economies occur if the average unit cost decreases with a greater project size, in contrast to the average unit cost increasing as the project size increases, which results in scale diseconomies. Empirical data are required in order to establish the economies of scale for various types of facility. A linear scale exists if the focus is on only one variable. For example if the variable is the facility capacity and the response is the construction cost, then the cost relationship could be evaluated as follows (Figure 1):

$$y = a + bx$$

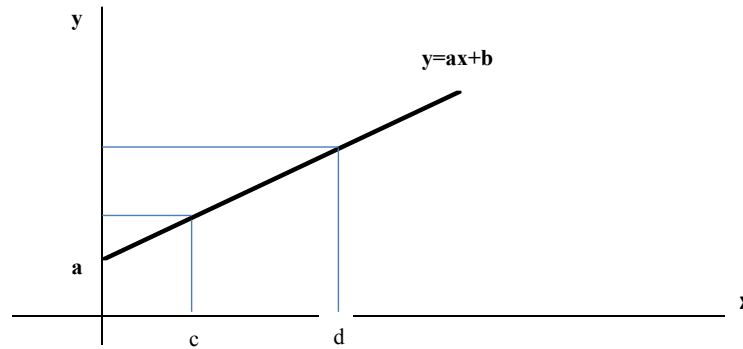

Figure 1: Linear Scale

It should be mentioned that a and b are positive constants determined based on the historical data available and that this function is applicable only for a specific range of the variable x . If the costs for points $x = c$ and $x = d$ are known, the cost for any point in the range between c and d could be evaluated by a linear interpolation. This function is applicable for the evaluation of costs such as those for a school building based on the floor area if the unit cost per square foot of floor area is known for school buildings and for a specific size limit (Hendrickson, 2008).

A non-linear cost relationship is often used in evaluating the total or partial cost for a new industrial processing plant based on the known cost of an existing facility of a different size. This term is referred to as the exponential rule. For example, to estimate the cost of a new facility with a defined capacity Q , from empirical data, the following assumption may be made (Hendrickson, 2008):

$$y = y_n \left(\frac{Q}{Q_n} \right)^m$$

where y_n and Q_n are defined as the cost estimate and the capacity for the existing project, respectively, and m ranges from 0.5 to 0.9 depending on the facility type. The above equation can be simplified as follows:

$$y = ax^b$$

Figure 2a indicates an increasing return ($0 < b < 1$) to scale and figure 2b indicates a decreasing return ($b > 1$). The same rules that apply in the linear method also apply here (Hendrickson, 2008).

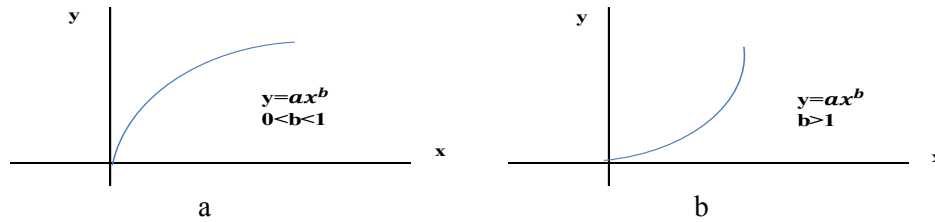

Figure 2: Nonlinear Scale

- *Unit Costs for bill of quantities*

The initial step in this approach is to break down a process into a specific number of tasks that must be achieved for a project to be completed. The quantity of the tasks is evaluated and a unit cost is allocated to each task. The total cost is then calculated through the summation of the quantities multiplied by the corresponding unit cost. It is worth mentioning that while this method might seem straightforward, it requires a great deal of effort in its application. Two methods that illustrate unit cost estimation are described below (Hendrickson, 2008).

The first is the simple unit cost method, which is defined as follows (Hendrickson, 2008):

$$y = \sum_{i=1}^n u_i Q_i$$

where n is the number of tasks decomposed, Q_i is the quantity of the i^{th} -element, and u_i is defined as the equivalent unit cost.

The second approach is referred to as the factored estimate formula, which is more common in process industries. Based on this method, the total project cost is estimated as the cost of purchasing and installing the major components of the equipment along with their supplementary items. The total cost of a project is estimated as follows (Hendrickson, 2008):

$$y = \sum_{i=1}^n C_i + \sum_{i=1}^n f_i C_i = \sum_{i=1}^n C_i (1 + f_i)$$

where C_i is defined as the purchase price for item i , and f_i is a factor that accounts for the cost of the i^{th} required supplementary item. It is worth mentioning that this formula is based on an evaluation of the cost of the supplementary items, either as a fraction or multiplication of the purchase cost of the equipment.

- *Allocation of joint costs*

The idea behind this approach is to produce a cost function for an operation based on the assignment of the expenditure to existing accounts. Ideally, there should be an informal relation between the allocation of joint costs and the category of basic costs which are classified as (1) labour, (2) material, (3) construction equipment, (4) construction supervision, and (5) general office overhead. It should be mentioned that, in many instances, this relationship might not be defined or even exist (Hendrickson, 2008).

2.6 Target Rate Theory and Applications

The dictionary definition of target is “an object or area toward which something is directed; one to be influenced or changed by an action or event; a desired goal.” A target could be measured and defined differently based on the objective and the point of view; it could be evaluated as average, goal, baseline, critical value, minimum/maximum, or even as an inflection point. What is certain is that a target is a value that must be achieved by the following of specific steps and procedures as well as by the detection of factors that influence the rate and the minimization of those that are barriers to achieving the target rate. Different sciences, such as computer, engineering, social, environmental, medicine, and business, set target rates for different purposes. In construction, setting targets is limited primarily to productivity: cost, schedule, and quality, all of which are dynamic in nature. A number of challenges are therefore inherent in the target-setting procedure. To provide a clearer understanding of this section, the following examples of setting targets in different fields are provided and illustrate the importance and advantage of doing so.

In Finland, Laitinen and Rouhomäki (1996) reported high accident rates in the building industry prior to 1996. They argued that the safety inspections carried out at Finnish sites was ineffective and therefore developed a new method of running standard weekly inspections, based on participation and the principles of performance management. In consultation with the company’s safety personnel, eight safety rules were formulated and were applied at two sites. After a baseline result was determined based on the first observation, an information meeting was arranged for all workers. The safety index from each weekly observation was marked for everyone to observe. For both projects, inspection began in January

1992, with the goal of reaching the targets in March 1993. The average safety index for the first project was 60 % in the baseline phase, and based on a variety of standards, the goal was set to be a minimum safety index of 80 %. After two months of feedback, the index increased to 82 %, and by March, an average index of 89 % was achieved. For the second project, the baseline average rate was 67 %, and the minimum goal to be achieved was set at 85 %. The average value attained by March was 91 %. The increase in the safety index to an overall average of 90 % also led to improvements to nearly 100 % in the sub-indexes, such as protection against falling, machine safety, scaffolding, and the use of personal protective devices. The authors believed that the success of their method was due to the involvement of supervisors, the information meetings, the goal setting, symbolic rewards, and weekly feedback (Laitinen & Rouhomäki, 1996).

Based on a study conducted by McGill University and the University of Toronto in 2010, it was reported that in North America and Western Europe, of students who enroll in four-year universities, 25 % never finish. Factors such as lack of clear goals and motivation, disorganized thinking, mood dysregulation, financial stress, and relationship problems may lead to academic performance difficulties and increases in the course dropout rate (Braxton et al., 2004; Dale & Sharpe, 2001; Kuh, Kinzie, Buckley, Bridges, & Hayek, 2007). Researchers created two sets of experiments with the goal of improving educational performance, validated the results through statistical models, and then indicated which program was more beneficial. Previous studies have shown that personal goals reflect meaningful personal objectives that guide perception, emotion, thought, and action (Elliot, Chirkov, & Kim, 2001; Wiese & Freund, 2005). The first program therefore involved the students setting and defining personal goals during their university studies as well as determining the procedure for achieving them. The goal-setting approach was formalized, intensive, and online. The second set of experiments was a control task program. Eighty-five first-year McGill undergraduate students participated in the experiment, whose duration was four months. Half were randomly chosen for the first program, and the remainder of the students joined the second program. The baselines for both groups at the beginning of the study were equivalent. At the end of the study, when the results of the two programs were compared, the first program proved more beneficial because the group who completed the goal-setting exercise achieved three objectives that the second group was not successful in accomplishing: increased GPAs, higher probability of maintaining a full course load, and reductions in self-reported negative affect and emotions. The first method was straightforward, inexpensive, appropriate for broad implementation, and available to a large number of

students. Figure 3 shows the GPA results for both programs at the end of the study (Morisano, Phil, Shore, Hirsh, & Peterson, 2011).

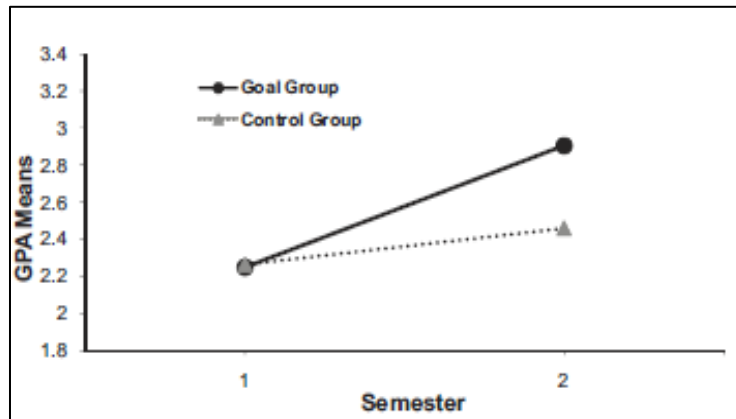

Figure 3: Overall grade points for goal & control group before and after the study

An additional example that illustrates a successful target-setting procedure and implementation is based on an approach known as Six Sigma, which is described as a philosophy, methodology, and breakthrough strategy for solving problems (Dedhia, 2005). Six Sigma was first developed by Bill Smith at Motorola during late 1970s, with the objective of providing control at the parts per million (PPM) level. This method focuses on measuring the quality of a product or services, reducing variations, deriving process improvements, and reducing costs. It uses a set of statistical and management tools that can create leaps in improvement. This approach has a failure rate of 3.4 parts per million, or a 99.99966 % defect-free product (Dedhia, 2005). Pande and Holpp (2002) defined Six Sigma as a statistical measure of the performance of a process or a product, a goal that reaches near perfection with respect to performance improvement, and a system of management for achieving lasting business leadership and world-class performance. This methodology can be applied regardless of product complexity or dissimilarities between different products and processes. Higher sigma values indicate better products and procedures with fewer defects per unit of service. It has been argued that a 3.8 sigma value indicates correctness 99 % of the time, which may seem satisfying, but a 1 % error rate may be equivalent to a large number of mistakes. As Chowdhury (2001) states, a 1 % error rate is equivalent to the loss of 20,000 pieces of mail every hour and four accidents per day at major airports. With Six Sigma, the desired goal to be achieved is determined differently in different organizations, but usually follows a cycle that includes five phases. In the entire cycle procedure, the first step is the most important and has the most impact on the other stages in sequence. It includes defining objectives and setting goals that must be achieved, followed by

measuring and analyzing the data to identify the root of the problems that are to be solved. The next step is to determine a solution and implement it, and finally to control the improved performance in order to maintain the desired level (Pheng & Hui, 2004). Based on the many books and articles that have been published since 1999 with respect to Six Sigma and its implementation in a variety of areas, Six Sigma has been found to have significant benefits: (1) a decrease in the amount of work in progress; (2) improvement in capacity, output, customer satisfaction, process flow, and less inventory in raw material and finished product; (3) an increase in productivity; and (4) a reduction in cycle time. The following are some of the successes achieved through the use of Six Sigma in recent years (Dedhia, 2005):

1. The Motorola Legal Department took two years for a patent application. Bob Galvin wanted the patent department to determine how to make the application time less than 90 days. Using the Six Sigma tools, the patent department reduced the time to somewhat less than that, with the shortest time being 17 days. Motorola generated a savings of \$1.5 billion over an 11-year period.
2. The cost of a Japanese patent system's application process was reduced from \$48,000 to \$1200 for each filing.
3. The National Science Foundation achieved a reduction in the number of sick people evacuated from Antarctica to 22 % with help from Raytheon Corporation with respect to finding ways to pre-screen scientists prior to engaging them.
4. The local government of Fort Wayne, Indiana, filled 98 % of the city's potholes within 24 hours using Six Sigma projects.

Chapter 3: Validation of Activity Analysis

While the effectiveness of Activity Analysis has been validated in general, it had not been applied in the Canadian business and project environment until this study. Doing this was necessary to gain insight into its proper application in Canada and to isolate key factors that would influence subsequent setting of target rates.

3.1 Background

As discussed in the literature review, Activity Analysis as a “continuous productivity improvement guide” has been executed and validated by previous research work on this tool. The hypothesis that Activity Analysis, as a continuous procedure, can improve the direct work rate has been validated from two distinct perspectives (Gouett et al., 2012):

1. The completion of case studies of six projects has verified that Activity Analysis as outlined is logically feasible.
2. The collection of data from two major contractors who completed the Activity Analysis cycle for 16 construction projects has verified this tool as a continuous productivity improvement process by indicating the improvement in the direct work rate compared to the initial study. Figure 4 shows the improvement in the direct work rate achieved through each cycle.

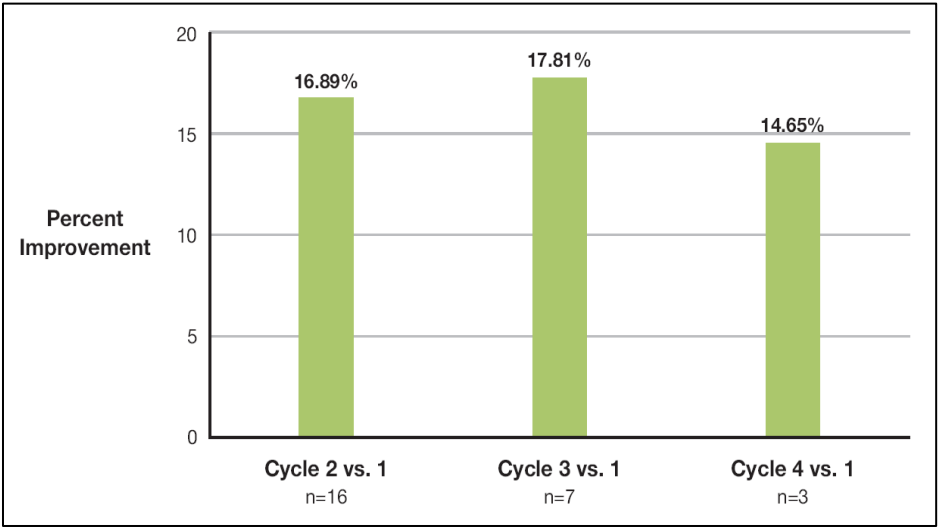

Figure 4: Average percent direct work improvement of successive cycles compared to cycle 1

The purpose of this chapter is to provide results and recommendations based on an Activity Analysis productivity study of three project sites designated Southwestern and Southeastern Ontario. It also provides input to subsequent target rate setting. All three sites had the same contractor. The Southwestern Ontario projects, which also had the same owner, were visited a first time, followed by a period of implementation and a second visit to each site. The Southeastern Ontario project was visited only once and is discussed at the end of this chapter. For completeness, the data and analysis are reported for each site visit. The chapter also includes a detailed section about communication with craft workers on site.

It is also noted here that exact details of project operations; project locations; and the names of the contractor, subcontractor, and owner are not provided because of their proprietary nature. This restriction allows the author to present some of the project specifics, including all results from the studies, while maintaining the contractor’s anonymity.

As mentioned, craft workers from each trade were observed in their typical daily activity on an hourly basis. Each individual observation was taken instantaneously during specific, randomized routes throughout the day. Workers’ activities were classified as one of seven categories: direct work, preparation work, tools and equipment, material handling, waiting, travel, or personal. Figure 5 shows the form used during the site visits.

Date	10/08/2011		Day	ONE						
Observation #	1		Start Time	7:00		Stop Time	8:00			
OBSERVATION WORKSHEET	Category	CRAFT						T O T A L	COMMENTS	
	Head Count								There is a design issue that prevents pipefitters from working.	
	Craft	PF	Civil	Operator	NA				Weather is pleasant for work.	
	Identifier									
	Direct Work						14			
	Prep Work								14	
	Tools/Equip						8			
	Material Handling						10			
	Waiting								4	
	Travel						7			
Personal							6			
TOTAL	12	26	11	14			63			

Figure 5: Activity Analysis sheet

After each site was visited, data were compiled and analyzed in order to determine the rates for each activity on an overall, hourly, and trade-specific basis. The results from the second visit to each site enabled a more in-depth comparison and investigation, as explained in the later sections of this chapter. Explicit details about site-specific conditions such as location, weather, and the number of each trade are noted. Both positive and negative factors that could have affected the productivity and activity rates at each site are also provided.

3.2 Procedure of Implementing Activity Analysis for Continuous Improvement

The quantitative results for the Activity Analysis for each site are divided into three sections: overall, hourly, and trade-specific. The overall rates show how the site performed on average in each of the seven categories across 3 or 4 days. The hourly analysis breaks down the data into each of the working hours in each day in order to provide a better understanding of how direct work and other activities fluctuate throughout the day. Finally, a trade-specific analysis was performed in order to compare how each trade spent their time during the 3 or 4 days. The analysis of each trade permitted a comparison of each corresponding subcontractor between sites. Data were collected on an hourly basis. Each observation noted both the activity and the trade, and tables were created. When the trade designation was unclear, ambiguous observations were recorded and later applied proportionally based on trade head counts (reported as NA). Qualitative notes were also taken to be combined with the statistical results in order to enhance the interpretation of the data. It should be mentioned that this research was conducted for the purposes of site productivity studies only; neither craft workers nor personnel in charge were studied or recognized individually.

As discussed in the literature review, Activity Analysis is a procedure that continuously follows five steps, as illustrated in Figure 6.

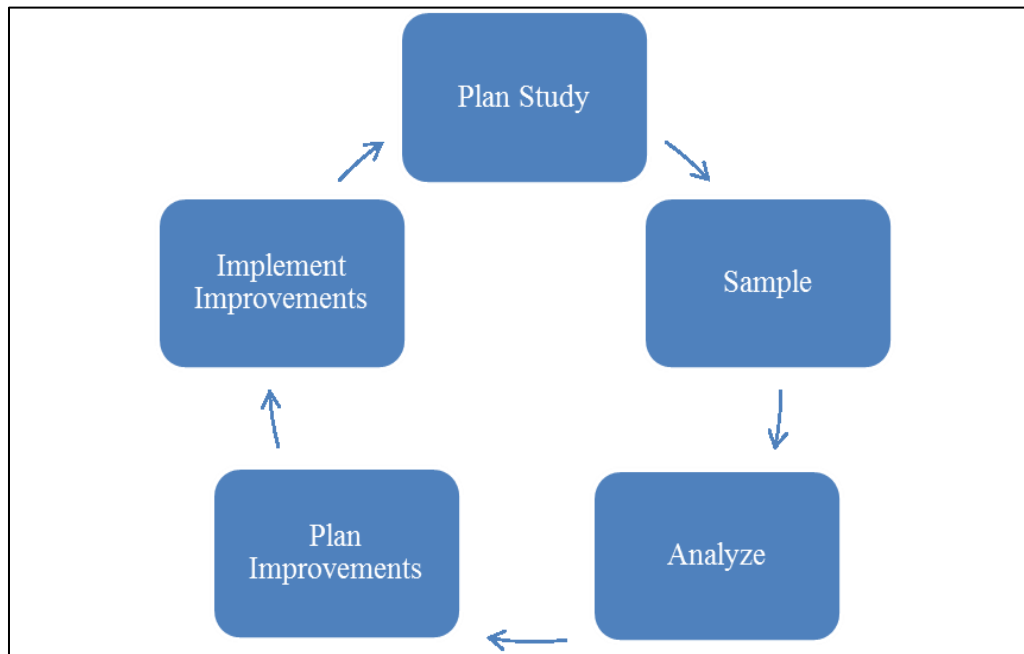

Figure 6: Activity Analysis Procedure

These steps were followed during the implementation of Activity Analysis as a continuous improvement process on the sites studied. To clarify Figure 6, it should be noted that the continuous nature of the improvement process is indicated by the connection of the implement improvements step with the plan study step. The purpose of this connection is twofold. First, as Jenkins (2003) argues, it should be proven that the changes implemented created an increase in the direct work rate. Liou and Borcharding (1986) stated this concept best:

“In order to improve productivity, one has to measure labour performance against some sort of standard before and after improvement measures have been introduced to reveal the usefulness of the corrective action.”

Comparing the first study with the second reveals the results of the changes. Secondly, once a second study has been conducted, the results can be used to identify further productivity barriers that may have arisen since the first study or that were not identified earlier. This feature creates the cyclical process of conducting the study, analyzing the results, implementing improvements, conducting another study to validate changes, and using the results for further improvement. The schedule of conducting studies should not be predetermined; instead, it should reflect the needs of the individual construction project. For example, if the initial study determined low direct work rates, it is important that a second study be

conducted relatively quickly, because determining early on whether direct work rates have improved is important. However, if the improvements required are minimal and may have only a minor effect on direct work rates, another visit may not be required for several months (Gouett et al., 2012).

3.2.1 Best Procedure for Introducing the Craft Workers to the Study

The initial strategy for explaining the role of the observers at a site was to brief the site superintendent and general foremen about the purpose of the study and subsequently to have the message passed on to workers from a familiar supervisor. Although nearly acceptable, this strategy led to miscommunication if there was any slight misunderstanding on the part of the superintendent or foreman. It also prevented a breaking-the-ice initial contact between the observers and the workers. Following several visits to different sites, it was determined that a brief, personal introduction to all craft workers during the morning toolbox meeting would be the most effective method of gaining the support of the workers during the observations. As Activity Analysis experts have always suggested, a craft information session is critical for explaining the purpose of the study and avoiding any ill will or altered behaviour on the part of the workers being observed. Giving a personal speech to the workers offers the observers the chance to extend candid, open invitations for the workers to ask any questions they may have about the study. The observers can emphasize that neither individual tracking (i.e., names) nor the specific timing of tasks will be recorded. Furthermore, the open communication channel can provide an opportunity for workers to speak directly about their discontent with any aspects of site organization or management. These anonymous testimonies can be very valuable as supplementary information.

Observers should arrive early (15-20 minutes before the start of work) to ask permission of the site superintendent or foremen to speak for 1-2 minutes at the beginning or end of the morning toolbox meeting. If any major subcontractors are on site, they may hold separate toolbox meetings in their own trailer. In this case, a priority decision must be made, with the possibility of visiting the second trailer either during the first morning break (not recommended, although acceptable depending on the attitudes of the specific workers) or during the second day's morning toolbox meeting.

It should be mentioned that the more open and honest observers are about the research and the goals of the observation, the more relaxed the craft workers will be while working. The main objective is to encourage the craft workers to understand that the data is not for evaluating them individually.

In the absence of craft identification markers, an added benefit of visiting each trailer for the morning toolbox meeting is the ability to recognize the faces of the workers in each trade. Less time is then required for identifying each trade during the data collection.

3.2.2 On-Site Responsibilities of the Observers

Approach

A reference document that provides full details about Activity Analysis should be provided for the engineers in charge. It should be explained to the project coordinators that, after analyzing the data and based on the observations, the observers may develop ideas in collaboration with site management in order to increase the direct work category. The explanation should include the information that the next step will be the implementation of the ideas with the cooperation of the site leadership and that a second visit will be required in order to evaluate the resulting changes.

A lesson learned from previous site visits prior to this research is that it is more effective to interact with the site project coordinators regarding both the recommendations and their implementation. People are motivated to make changes when they understand the reasons for them and have contributed to the change process. The main goal is to have both parties confirm the recommendations as well as how and when to implement them. Without their coordination Activity Analysis would not be an effective tool for the site and the data gathering would be wasted time. There should be constant communication between the observers and the project coordinators regarding what has been implemented and what is infeasible. A close working relationship between the coordinators and the observers prevents misunderstanding and problems.

Execution

The observers walked the site in order to take snap observations of workers. Specifically, they constantly carried a clipboard and walked random routes through each area of the site. As explained above, the observers attended the morning toolbox meeting to explain their role on the site.

Observers were required to gain the co-operation of the site coordinators, the superintendent, the foreman, and the administrative staff in order to obtain detailed information about site dynamics and regular behaviour. For example, obtaining head counts for the week from site staff was essential. The goal was for observers to act independently and not to interfere with the work.

It should also be noted that recommendations initiated separately by the project manager may also have been implemented as a means of improving site productivity for the second set of observations, but again, Activity Analysis is a continuous process that includes such changes.

Time line

The observers required about four full days (7 am – 5 pm) on site in order to perform the data collection. The first day was budgeted mainly for site safety and orientation. Following that, the observers spent each hour making observations until they had collected a statistically significant amount of data.

Following their on-site time, the observers then analyzed the data. Once the activity rates were determined, they were able to provide the managerial level with recommendations and feedback.

3.2.3 Conclusion

1. When observers attend the morning toolbox meeting on the first day and explain why they are on site with a clipboard, work is easier for craft workers as well as for the observers.
2. Being open and honest with the craft workers and their questions reduces any negative impact that the observers might have during their time on site.
3. Relations between the observers and site project coordinators should be defined and should be consistent.
4. Prior to the observers' second visit, the project coordinators should be committed to implementing the recommendations on site and should indicate the recommendations that will not be implemented.
5. Time lines should be defined for each step throughout the entire procedure.

3.2.4 Implementing Recommendations More Efficiently

Previous studies have shown that in order to efficiently implement all site recommendations, productivity industry experts suggest performing the following activities before taking action (Gouett et al., 2012):

1. Obtain real commitments from all levels of management
2. Study each action element of the plan
3. Define a schedule and timeline for each element
4. Investigate the cost of implementation, including development, purchasing, and maintenance
5. Consider human resource issues, such as training and support for new implementations
6. Update forms and documents related to changed work processes

During the second site visits presented below, it was assumed that the above actions had been considered during the implementation stage.

3.3 LB Project

It is to note that for the ease of work, this project will be identified and presented as “LB” for the rest of chapters.

3.3.1 Site Overview

1. **Project size:** 36,320 m²
2. **Project type:** Brownfield, because of live gas remaining inside the pipes. A Brownfield site is more complex with respect to safety and planning than a Greenfield site.
3. **Activities:** pipe re-routing, tie-ins to existing lines, erection of concrete piers for heavy scrubbers, full site excavation and backfill as required, and full electrical servicing between the three compressor buildings and the system control building
4. **Completion percentage at time of analysis:** 47 %
5. **Approximate Location:** Southwestern Ontario

3.3.2 Overall and Hourly Categories Analysis: First Site Visit

Figure 7 is a pie chart that illustrates the overall activity rates for the first site visit at the LB project.

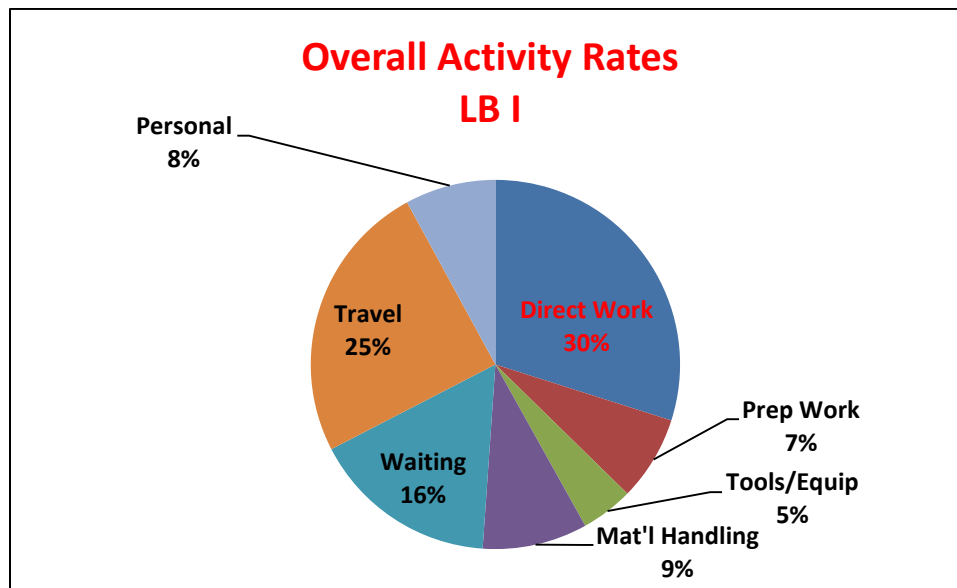

Figure 7: Pie Chart showing overall activity rates, LB I

Figure 8 shows a roller coaster chart of the overall hourly activity rates for the same site visit.

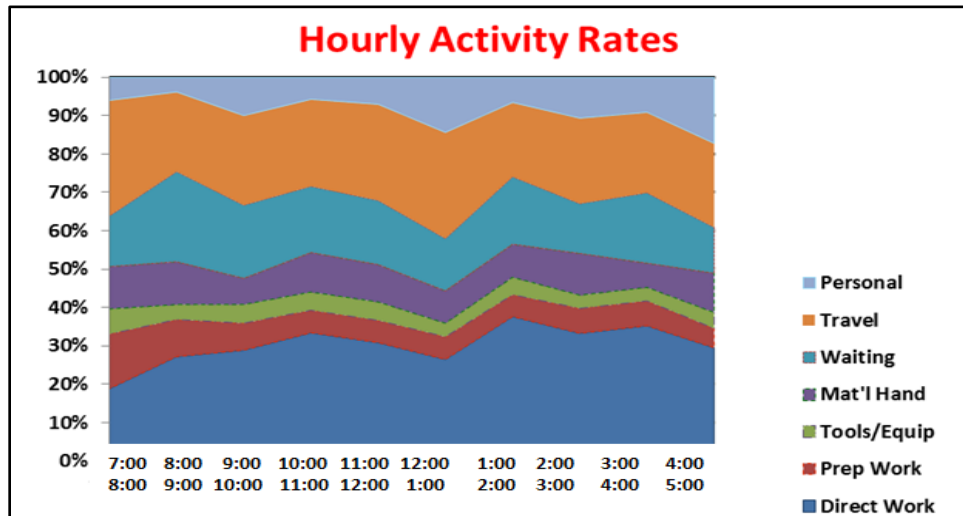

Figure 8: "Roller coaster" chart showing overall hourly activity rates, LB I

3.3.3 Trade Analysis

Table 1 shows the site information while it has been visited, such as the detail of available trades on site, and temperature for each day. As it is shown, site population and work hours/day (i.e. each trade specifically) was consistent through the observation duration.

Table 1: Daily temperatures and trade head counts, LB I

		May-31-11	01-Jun-11	02-Jun-11	03-Jun-11	Work Hours/Day
Temperature		23.8°C	19.1°C	11.8 °C	14.2 °C	
#	Trade	# Available on Site	# Available on Site	# Available on Site	# Available on Site	
1	Pipefitters	24	24	24	24	10
2	Civil	15	15	15	15	8
3	Electricians	10	10	10	10	10
4	Operators	5	5	5	5	10
Total		54	54	54	54	

Table 2 illustrates the number of observations counted for every category and trade for the first visit to LB site.

Table 2: Total activity observations by trade, LB I

Trade Category	Pipefitter	Civil	Electrical	Operator	Total
Direct Work	1114	508	171	471	2264
Prep Work	291	146	69	56	562
Tools/Equip	150	114	35	48	347
Mat'l Handling	298	275	75	48	696
Waiting	637	307	125	166	1235
Travel	832	532	278	224	1866
Personal	254	154	100	93	601

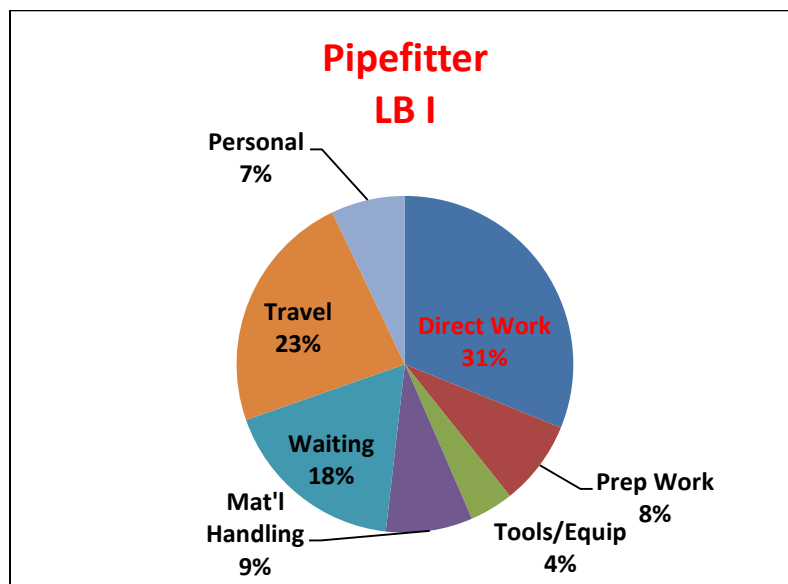

Figure 9: Pipefitter activity rates, LB I

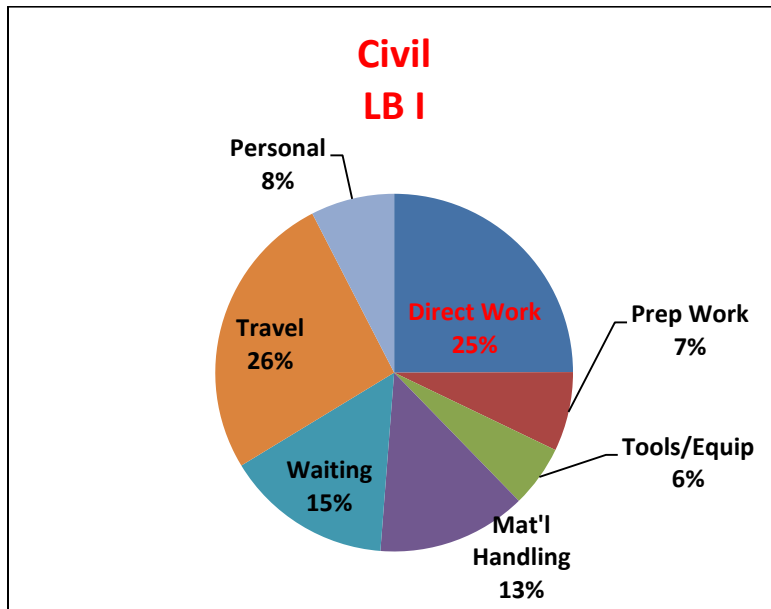

Figure 10: Civil activity rates, LB I

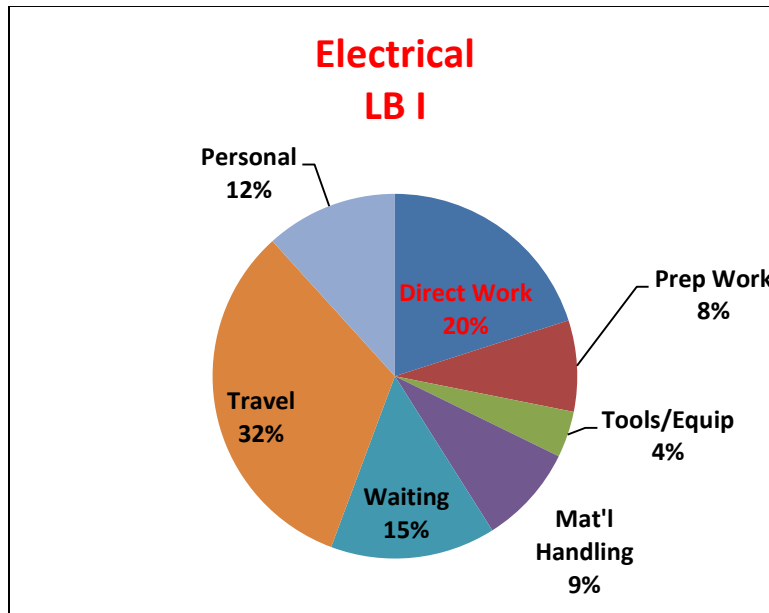

Figure 11: Electrical activity rates, LB I

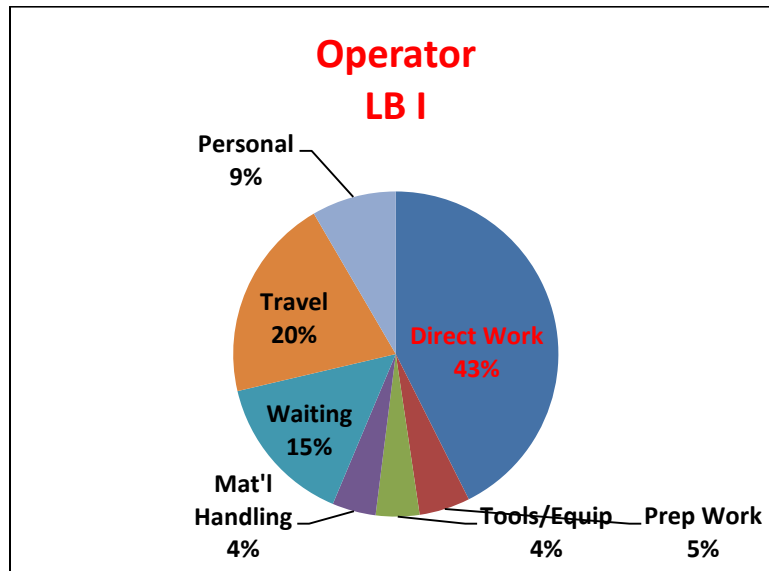

Figure 12: Operator activity rates, LB I

The four completed pie-charts in Figures 9 – 12 provided a successful starting point for the analysis of the LB trades. These rates were then used as a basis for comparing activity rates before and after the implementation of the recommendations.

3.3.4 Positive and Negative Points Observed

Positive

1. A friendly atmosphere and good communication between highly experienced project coordinators and the craft foremen were observed.
2. Delegating well-scheduled worker tasks in the mornings allowed better work flow. For example, an hour was put aside on Monday to excavate an area entirely so that, on Tuesday, other workers could be entirely focused on the piping in that location.
3. The well-organized overall schedule caused less interaction between different work phases. For example, the subcontractors who were required to test equipment (such as an X-ray machine) started work after 8:00 pm in order to avoid any interference.
4. The safety standards were very high and well implemented on site without interfering with the work.

5. Craft workers were committed to their work, even throughout their breaks and lunch times. The observation “throughout lunch/break times” was included because of workers not going for lunch or breaks on schedule.
6. Water, material, and washrooms were easily accessible.
7. The presence of the project coordinators outside of the trailer ensured that progress was checked and that they were kept informed of exactly what was happening on site.

Negative

1. The large number of owner inspectors interfering with work on site caused problems and created tension between them and the craft workers, including the foremen and coordinators. The craft workers became uncomfortable, which led to travel problems, a decrease in direct work, and even a decrease in the safety factor on site.
2. Off-schedule breaks and lunch times allowed the workers to continue with a specific task if it needed to be finished. Although this practice is primarily productive and sensible, it could cause a disorganized site, and some craft workers might take advantage and spend more time on lunch, for example, between 12:40 and 1:20. This situation leads to more travel and personal time and it decreases the direct work rate.
3. Previous initial site design and installation issues and incorrect mapping by the owner for the available pipes made the work slower and much more difficult for the contractor. More time should be spent fixing design issues and developing ideas in order to avoid problems. Dealing with major issues on the fly leads to significant delay and to a decrease in the direct work rate.
4. There was too much travel time caused by the large number of different subcontractors’ vehicles on site.
5. Long toolbox meetings sometimes took until 7:30 am due to the significant involvement of the owner representatives. Daily toolbox meetings of the craft workers and the owner inspectors are unnecessary.
6. The use of cell phones by the owner inspectors has the long-term effect of influencing craft workers to use them as well.
7. The long distance between the site and the break area, the trailers and the fabrication shop area increases travel time.

3.3.5 Recommendations

1. Decrease travel time by reducing the number of subcontractor and contractor vehicles on site.
2. Decrease the number of owner inspectors on site, or set up a different schedule for them in order to reduce the population density as well as the interaction between the contractor and the owner.
3. Organize breaks and lunch times in order to decrease overall indirect work activities. If necessary, schedule different lunch times for different trades.
4. Minimize the number of trades in one phase/area in order to decrease both the time spent waiting and a possible increase in the probability of safety concerns.
5. Organize the inspection of as-built/installed pipe mapping ahead of time, in order to reduce delay, waiting, and other negative aspects of this step.
6. Reduce the involvement of the owner inspectors in toolbox meetings.
7. Decrease the use of cell phones on site, by mentioning it either to inspectors or at a safety meeting, and let them know about the impact of their actions on the craft workers.
8. Create a break area or place with a shaded bench somewhere closer to the center of the site.

3.4 LB Project: Second Cycle, Following Implementation

3.4.1 Site Overview II

The recommendations were implemented on Tuesday, July 5, 2011. Greater emphasis was placed on the implementation of recommendations 1, 2, 3, 4, 6, and 7. To provide enough time for the site to adjust to the changes, the second visit to the LB site took place approximately five weeks after the above date. From Wednesday, August 10th, to Friday, August 12th, 2011, the site was visited for the second cycle of observation and data collection. It should be mentioned that 72 % of the project had been completed at the time of the second visit. During this visit, all trades (pipefitters, civil, electricians, and operators) included in the previous observation and data collection cycle were still available on site.

In general, the recommendations had been implemented on site, but not to the level expected. The impact was nonetheless noticeable in numerous activity categories. Communication between the parties in charge of making the recommendations and the parties in charge of the implementation was well organized and made the entire process easier. Responsibilities were understood from the beginning so that delay and misunderstandings were minimized during the implementation of the recommendations at this site.

It should be mentioned that this project was already ahead of schedule, which meant that most of the complex work, such as welding large pipes, installing them in the ground, and dealing with live pipelines, had been completed. Unlike the situation during the first visit to LB, on this visit, more tasks were related to civil work, such as backfilling, compacting, and building forms for concrete. Less yard work was related to the pipefitters' tasks, such as welding spools and assembling pipelines, although these were still occurring. A significant number of pipefitters were also observed to be working on small tasks in compressor buildings.

Specific conditions made observation more difficult and sometimes impossible. For example, the welders and the pipefitters could not be observed at all times because they were in buildings, and the civil personnel and pipefitters were working inside the excavation areas, which were difficult to access.

Below are some of the negative and positive changes observed at the site after the implementation of the recommendations. The results show the improvement on site at that time as well as additional improvements still needed. This information provides a better understanding of the importance of Activity Analysis as a continuous improvement process of measuring and then increasing the amount of time that craft workers spend on actual construction (i.e., direct work).

3.4.2 Visible Site Changes and Corresponding Advantages

Vehicles

- Vehicles were being used only when necessary, which decreased unnecessary travel.
- During working hours, decreased travelling of the craft workers on site was also observed.

Personal time

- Lunch times were more organized, with 90 % of the workers going to lunch on time and coming back at 12:30.
- The use of cell phones did not change on the site, and owner inspectors and some of the craft workers were still using them, which increases both personal time and safety issues.
- No benches were available close to work areas. Significant travel was still required for the craft workers to reach their trailers or the washrooms.

Using time more efficiently

- Morning toolbox meetings took less time than had been observed during the first site visit, which enabled the craft workers to start work earlier in the morning when they were less tired.
- Decreased congestion of craft workers in one working area/phase reduced the waiting time and also facilitated the work on specific tasks.
- Fewer owner inspectors on site made work easier for the craft workers with respect to a variety of considerations, such as less dense work areas/phases and less tension evident between the owner inspectors and the craft workers. This improvement saved indirect work time during the day.
- Storage areas were still a significant distance from where the work was taking place, which caused more travel time to obtain a specific piece of equipment/tool/material required for the performance of a task.

Barriers

- Additional ground path barriers, such as holes, made it harder for craft workers to travel and move around on site, and the site looked unorganized.
- Safety and hazard signs were more dispersed and not well positioned, making travel more difficult and adding to the unorganized appearance of the site.

3.4.3 Overall and Hourly Category Analysis: Second Site Visit

Figure 13 is a pie chart that illustrates the overall activity rates for the second site visit at the LB project and Figure 14 shows a roller coaster chart of the overall hourly activity rates for the same site visit.

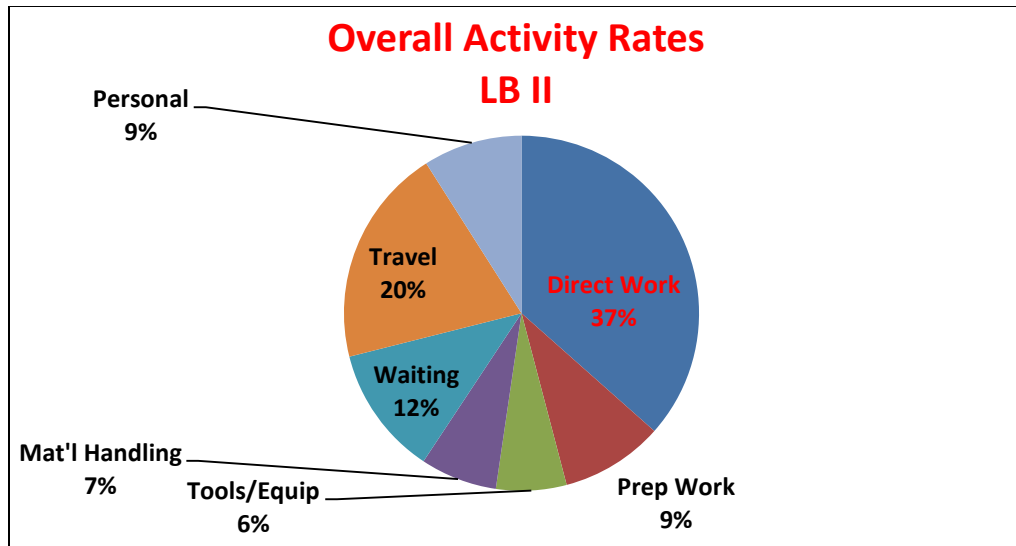

Figure 13: Pie chart showing overall activity rates, LB II

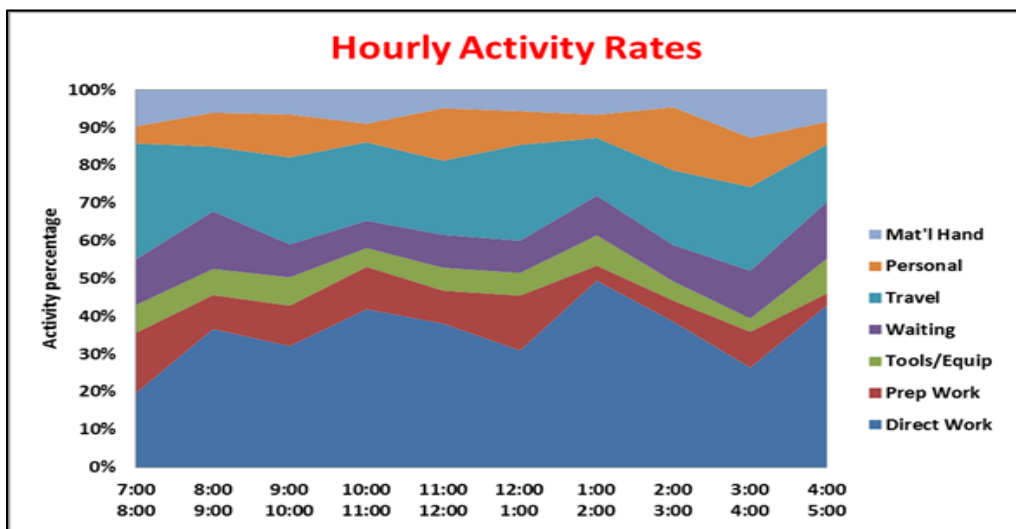

Figure 14: "Roller Coaster" chart showing hourly activity rates, LB II

3.4.4 Trade Analysis

Table 3 shows the site information while it has been visited, such as the detail of available trades on site, and temperature for each day.

Table 3: Daily temperatures and trade head counts, LB II

10-Aug-11				11-Aug-11				12-Aug-11			
Temperature		22°C	Work Hours /Day	Temperature		24°C	Work Hours /Day	Temperature		26°C	Work Hours /Day
#	Trade	# on Site		#	Trade	# on Site		#	Trade	# on Site	
1	Pipefitters*	25	10	1	Pipefitters*	25	10	1	Pipefitters*	25	10
2	Civil	18	8	2	Civil	18	8	2	Civil	18	8
3	Electricians	8	8	3	Electricians	8	8	3	Electricians	8	8
4	Operators	4	10	4	Operators	4	10	4	Operators	4	10
5	Painter SC**	2	-	5	Painter SC**	2	-	5	Painter SC**	2	-
6	Insulation SC**	4	-	6	Insulation SC**	4	-	6	Insulation SC**	4	-
Total		61		Total		61		Total		61	

* 19 pipefitters and 6 welders were on site but, to facilitate inclusion in the chart, are considered to be 25 pipefitters.

** Painters and insulation subcontractors are not included in the trade analysis, because they were not available during the first site visit. Since some craft workers were not recognized by the observers, these two subcontractors may have been included in the overall activity rates. They were counted in the NA column of the Activity Analysis sheet.

Table 4 illustrates the number of observations counted for every category and trade for the second visit to LB site.

Table 4: Total activity observations by trade, LB II

Trade Category	Pipefitter	Civil	Electrical	Operator	Total
Direct Work	439	275	60	292	1066
Prep Work	135	68	26	44	273
Tools/Equip	120	45	17	5	187
Mat'l Handling	102	73	25	4	204
Waiting	161	113	7	62	343
Travel	289	166	44	82	581
Personal	137	67	19	40	263

Figures 15 – 18 are presented for direct comparison with Figures 9 – 12.

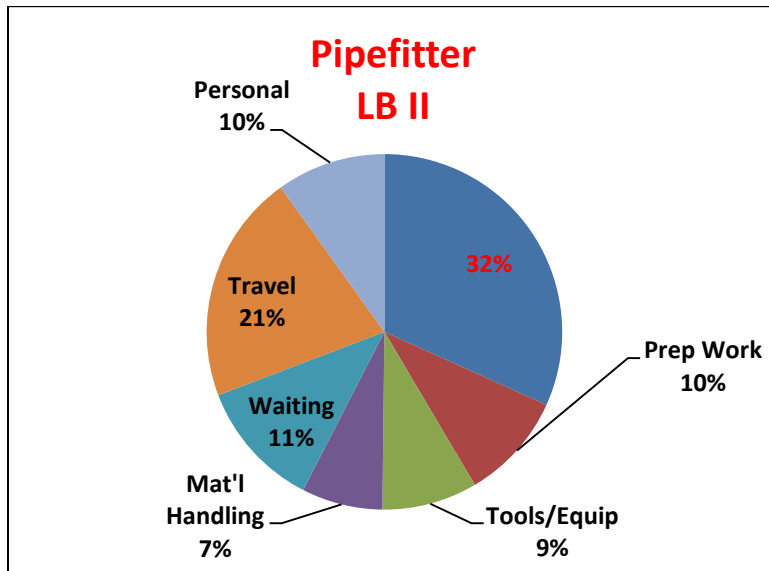

Figure 15: Pipefitter activity rates, LB I

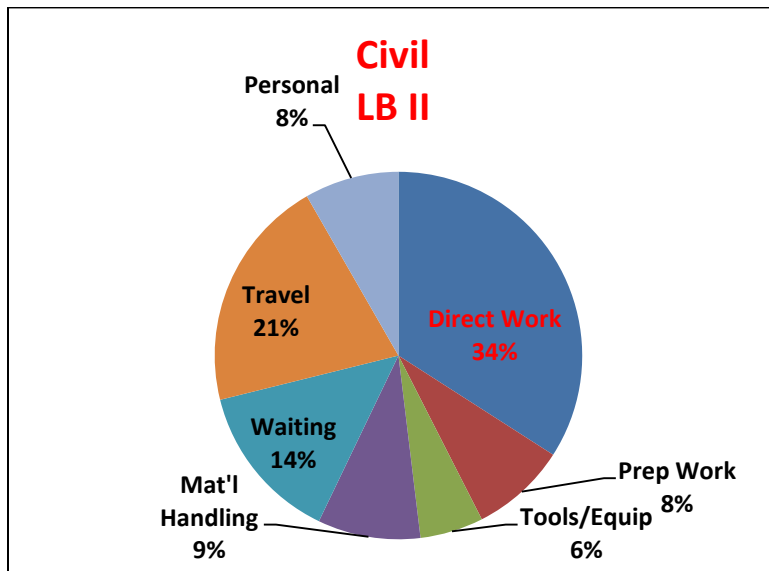

Figure 16: Civil activity rates, LB II

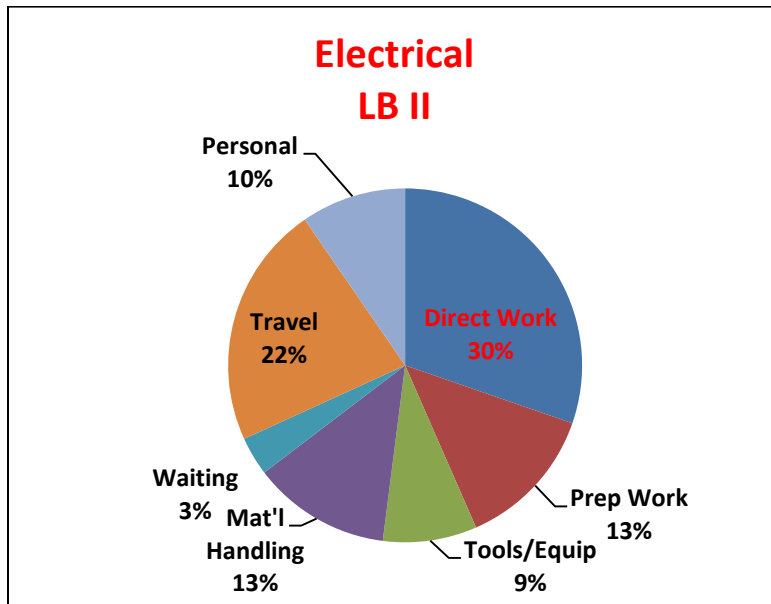

Figure 17: Electrical activity rates, LB I

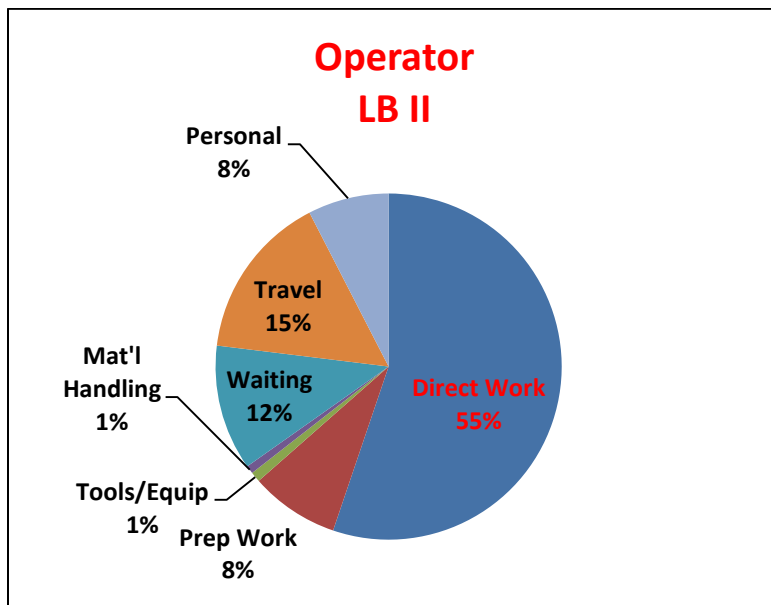

Figure 18: Operator Activity Rates, LB II

3.5 Comparison of the First and Second Cycles for the LB Project

3.5.1 Same-Trade Activity Rate Comparison: LB (I, II)

Figures 19 – 22 show a comparison of the activity rates of the same trades for cycles I and II of the LB project.

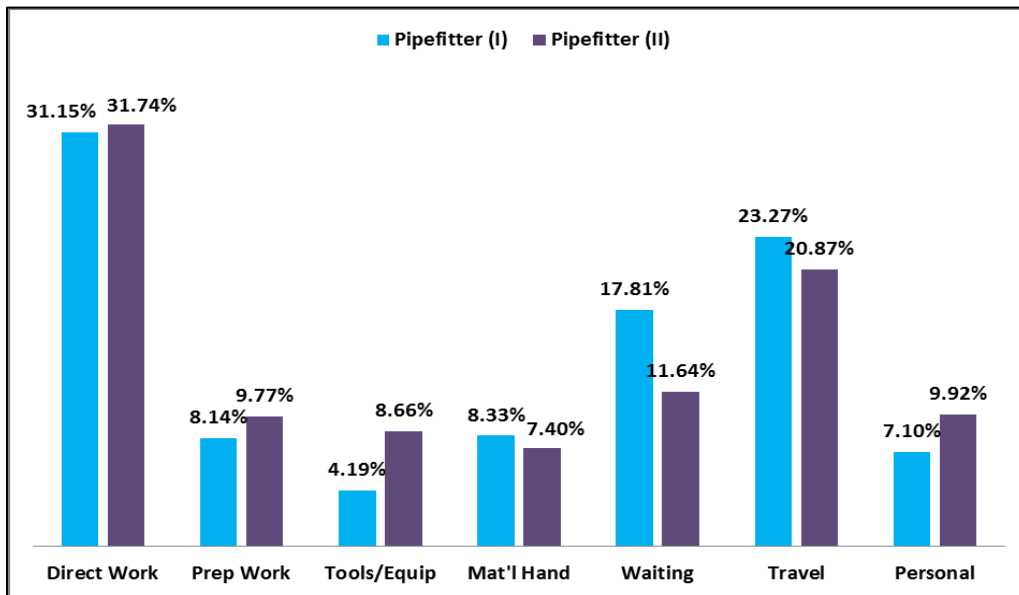

Figure 19: Comparison of the pipefitter activity rates (LB I and II)

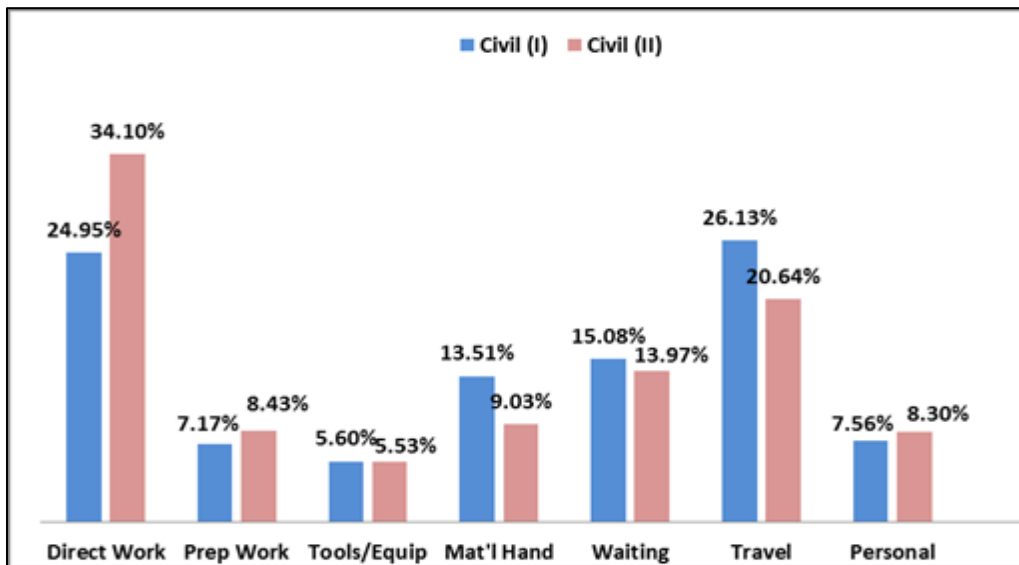

Figure 20: Comparison of the civil activity rates (LB I and II)

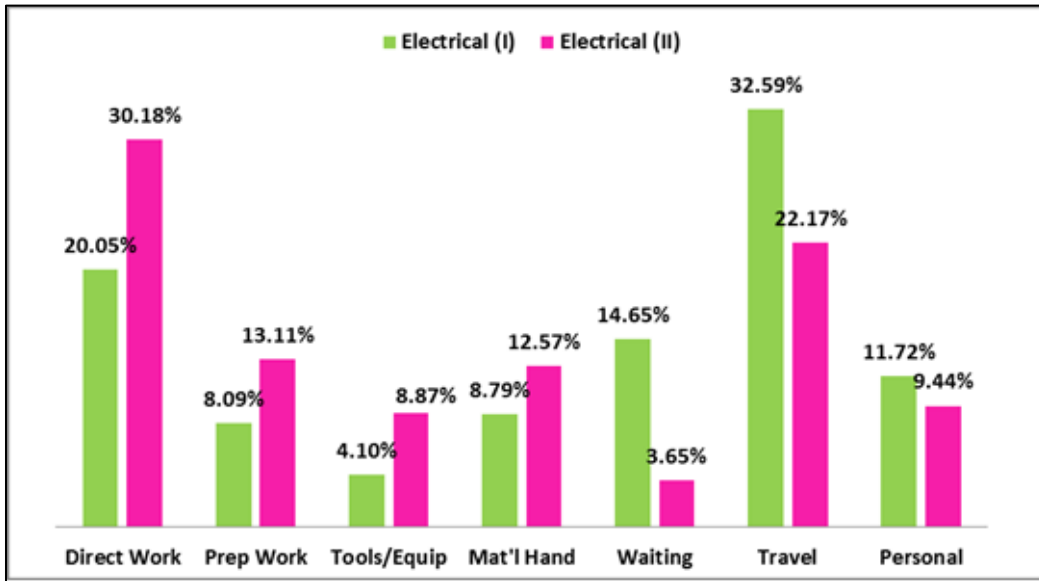

Figure 21: Comparison of the electrician activity rates (LB I and II)

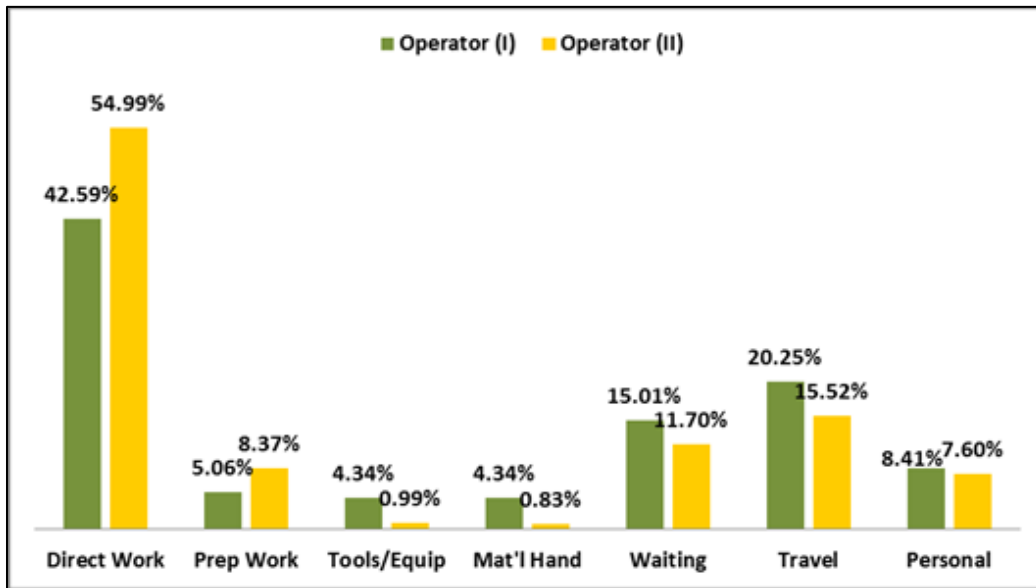

Figure 22: Comparison of the operator activity rates (LB I and II)

3.5.2 Trade Comparison Summary: LB (I, II)

Figures 23 – 25 show a comparison of activity rates by trade observed during cycles I and II at the LB project.

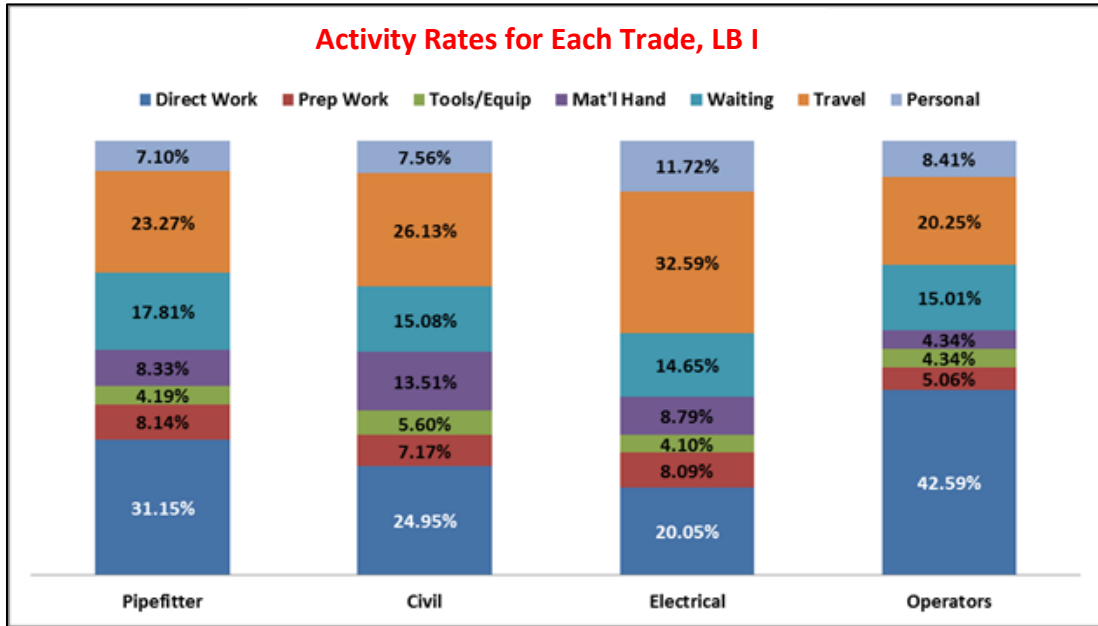

Figure 23: Activity rates per trade, LB I

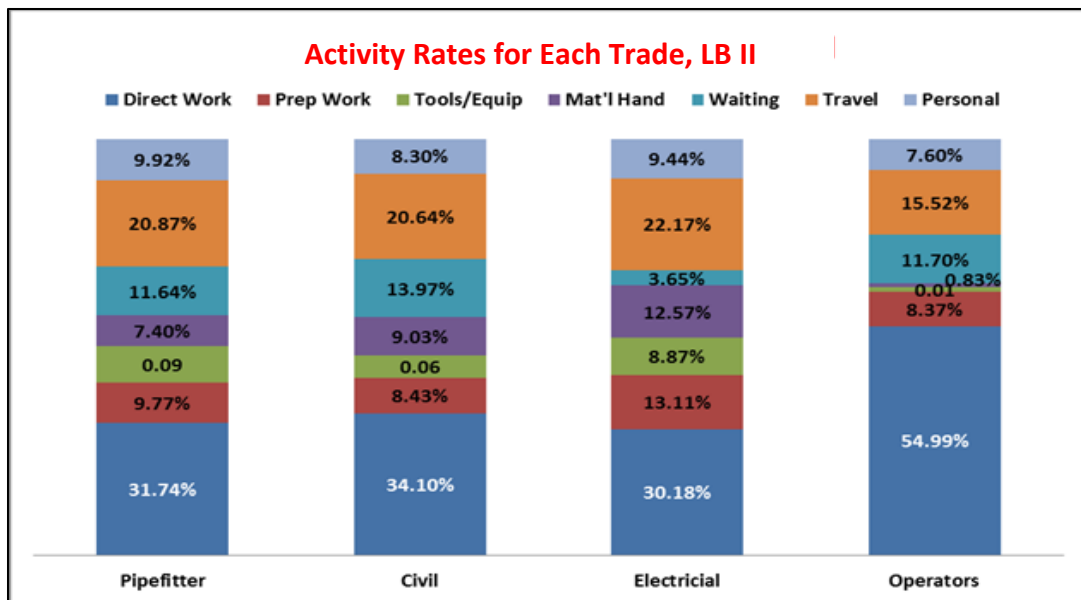

Figure 24: Activity rates per trade, LB II

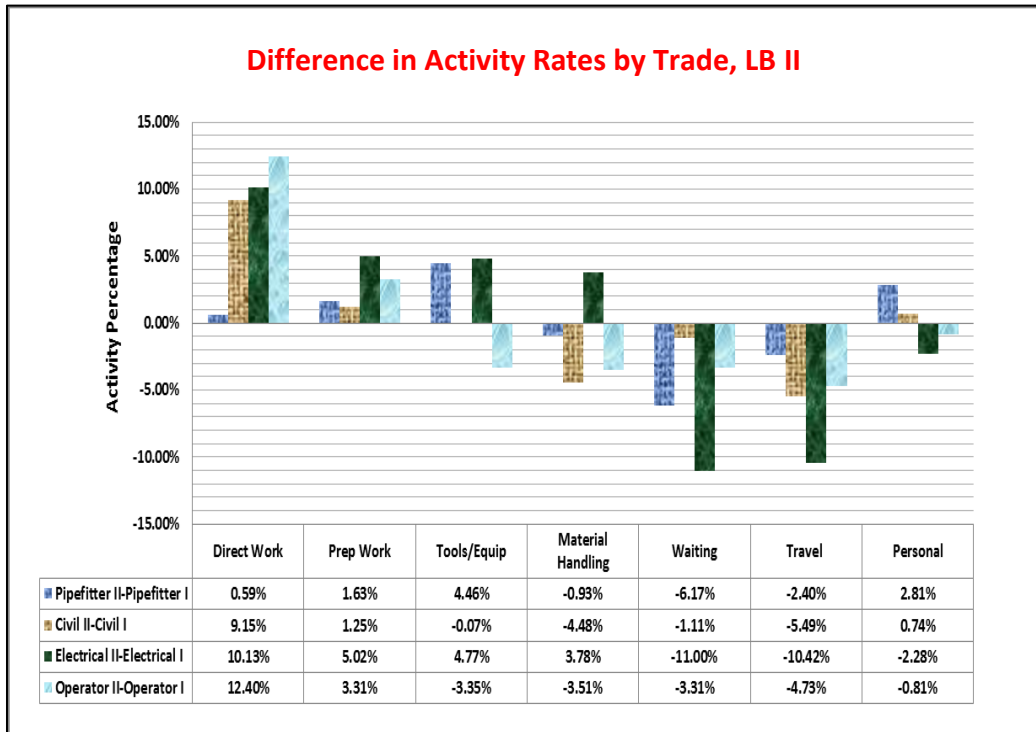

Figure 25: Difference in activity rates by trade, LB (I, II)

Figure 25 indicates the difference between the activity rates for each trade category for the two site visits at the LB project.

Direct Work exhibited a noticeable increase for all four trades. Statistics show that the rate is unique for each trade. It could be concluded that the complexity of the work is related to the increased rate for each trade. For example, civil work, which is less complicated, has increased by 9.15 %, while pipefitter’s work, which is more complicated and needs more preparation, has increased by only 0.59 %.

It should be mentioned that the increase or decrease in any of the seven categories relative to each trade would be different based on the scope and complexity of the work, the weather conditions, site conditions, the trades, and the number of craft workers on site. Although they may be similar, these rates vary from one project to another. This feature is a good example of the necessity of noting that the target rate is different for each trade and must be set based on the complexity of each trade’s job.

The following are possible reasons for the increase in the direct work rate on this site:

1. Less travel occurred on the site.
2. Less time was spent for morning toolbox meetings.
3. More civil work was involved during the second site visit rather than complex, large-bore welding by the pipefitters.
4. Most of the work had been completed by the second site visit.
5. Fewer owner inspectors were involved on site, which made the craft workers more comfortable while working.
6. As mentioned, this project was already ahead of schedule, which translates into a more productive atmosphere, which could also be related to increased direct work.

The reason that electricians have a significantly high direct work rate is that observers were not able to obtain accurate data for this trade because most of the time the workers were inside buildings and not visible on site. The relatively high level of direct work for the operators is due to the number of them available on site as well as the variety of tasks that required the involvement of an operator in order to proceed.

Preparation Work showed an increase for all four trades. One cause could be a higher number of changing tasks that had to be completed during the week, which would result in greater levels of sudden, impromptu planning. This category needed further study so that it could be investigated in greater detail.

Tools/Equipment showed a decrease for both operators and civil, but an increase for pipefitters and electricians. The reason for the discrepancy could be the location of the storage areas far from the area where the work takes place so that it takes the craft workers a longer time to return with or retrieve a tool from the storage area in order to work on a task. Since operators do not have to deal with piping, welding, or installing, they do not need tools and equipment as frequently as pipefitters and electricians do, which would result in a decrease in their tools and equipment activity rate.

Material Handling exhibited a decreased rate for all trades except electricians, which indicates that less time was spent providing the appropriate material for a specific task. This result could mean that craft workers were more prepared in the morning and/or at breaks and thus had the appropriate material while performing a task. It also potentially means that the materials required for a task were accessible and that less time was consumed acquiring the appropriate materials, such as small bores, weld, steel bars, or

cables. Overall, it could be said that less time was consumed acquiring the materials and more time was spent installing or welding them, which increases the amount of direct work. It should be noted that one of the causes of the increase in this activity rate for electricians could be insufficient data collection for this trade because of the difficulty the observers experienced in tracking them.

Waiting showed a decreased rate overall for all four trades, which shows better planning and preparation both in the morning and in general. It also indicates that the organization on site had improved. Less time was spent waiting to perform a task or to be told what needed to be accomplished. As well, less congestion during work phases leads to less waiting. It could be said that more time was spent in the constant performance of work with appropriate numbers of craft workers.

Travel exhibited a decrease for all four trades. A decrease in travel means that less time is consumed obtaining materials and reaching locations in order to work on a task. The time saved can be used to perform tasks more efficiently during the day. Less travel also means that craft workers are less tired during the latter part of the day. Again, the significant decrease in the travel rate for electricians is further evidence that the observers were not able to track them properly.

Personal showed an increase for civil and pipefitters but a decrease for electricians and operators. Due to the small changes in the percentages, changes in this category could be neglected and considered to be unchanged from the previous visit. The reasons for these results could be not having enough breaks during the day, due to the tight schedules, and not having proper benches or resting areas, which could increase fatigue during the day. More study was required so that this activity could be examined in more detail.

3.5.3 Overall Activity Rate Comparison, LB (I, II)

Figure 26 illustrates the comparison of overall activity rates for both visits to LB and Figure 27 shows the differences in the overall activity rates for the same site visits.

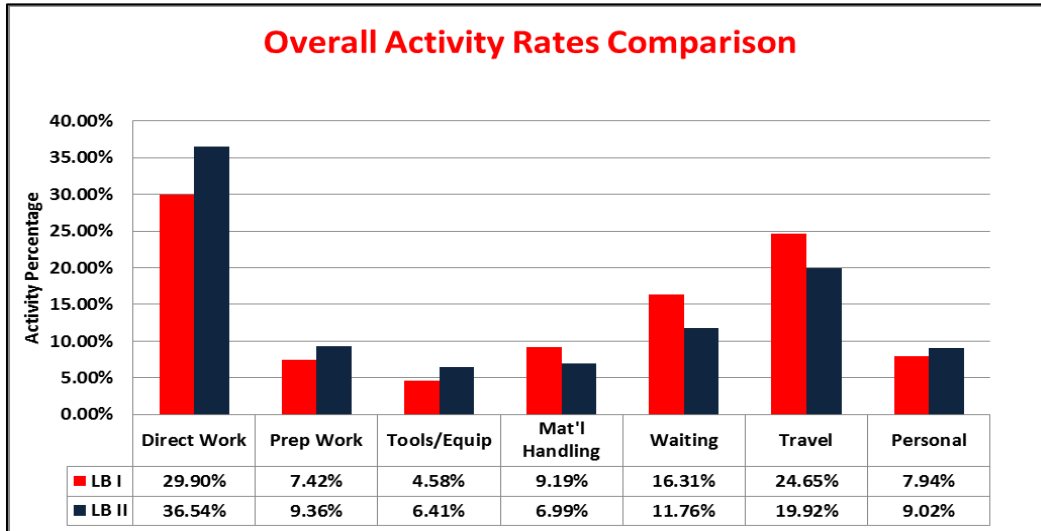

Figure 26: Comparison of overall activities, LB (I, II)

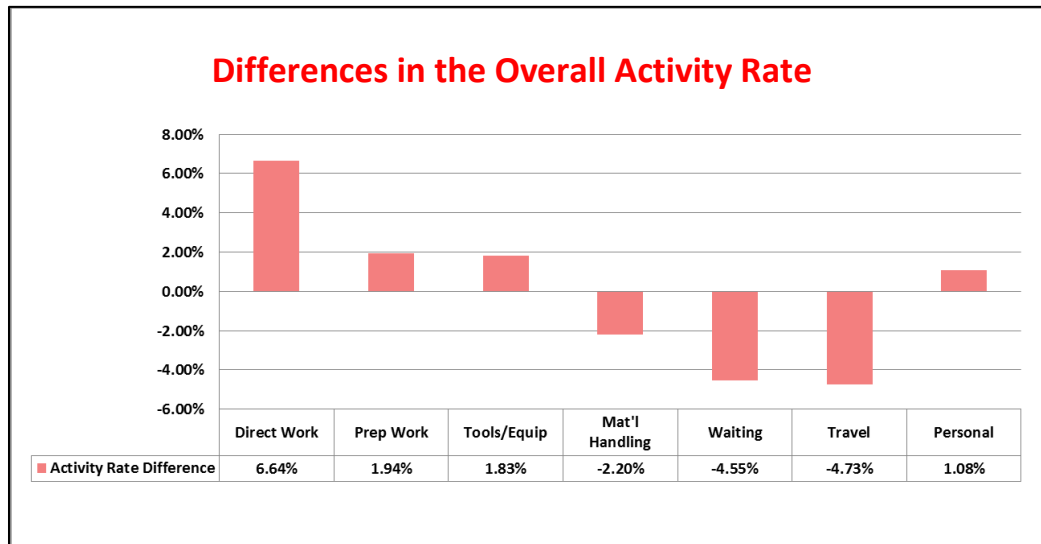

Figure 27: Differences in the overall activity rate, LB (I, II)

As shown in Figure 27, the overall activity rates for both LB site visits were compared. All conditions that might have influenced site productivity for both visits were considered, and nothing was neglected. In

other words, all of the observations during both site visits were incorporated into these charts, including all the conditions noted. A positive sign indicates an increase, and a negative sign represents a decrease for a particular activity rate. Based on Figures 26 and 27, the activity that increased the most was direct work (6.64 %), and the activity that decreased the most was travel (-4.73 %). The activity that remained almost unchanged was personal (1.08 %). Based on Figures 26 and 27, the activity that increased the most was direct work (6.64 %), and the activity that decreased the most was travel (-4.73 %). The activity that remained almost unchanged was personal (1.08 %).

3.6 LB site summary

Based on Figures 26 and 27, the application of the Activity Analysis tool at the LB site correlated with an overall increase of 6.64 percentage points or a 20 % increase in the preceding direct work rate. As mentioned, however, this site was ahead of schedule, so the Activity Analysis tool was not the only reason for the increase.

Preparation work increased by 1.94 percentage points. One possible reason for this increase could be that more time was spent understanding what needed to be done so that tasks could be performed effectively rather than waiting or not working efficiently. The tools and equipment category showed an increase of only 1.83 percentage points, which was caused by the failure to relocate the storage areas. Waiting time decreased by 4.55 percentage points, which shows good progress in the preparation of activities ahead of time in tool box meetings, for example, rather than during work hours. Travel time decreased by 4.73 percentage points, which is a significant achievement; although trailers and storage areas were still far from work areas, craft workers were able to manage work with less travel. The personal category increased by only 1.08 percentage points, which could be neglected. It should be mentioned that these percentages were based on the actual conditions at the site and that nothing was omitted from the evaluation. For example, during the first visit to LB, the insulation subcontractor and the painter subcontractor were not available on site but were tracked as unknown on the second visit to LB and were included in the evaluation of the overall activity rates. All of this information has been taken into account in the discussion presented in this section

It is important to note that since a combination of pipefitters, civil workers, operators, and electricians were on site, a unique direct work rate target can be found that lies somewhere among the individual standards for each trade. Based on available articles and papers that explain how to define and set targets,

a direct work rate of 36.54 % is a very good achievement after approximately five weeks of implementation.

It can be concluded that since Activity Analysis is a continuous process for improving the direct work rate, after the implementation of the recommendations for the second time and the collection of data for the third time, better results would be expected on site.

3.7 DN Project

It is to note that for the ease of work, this project will be identified and presented as “DN” for the rest of chapters.

3.7.1 Site Overview

1. **Project Size :** 20,000 m²
2. **Project type:** Greenfield. No live gas is present.
3. **Activities :** groundwork for the entire site; erection of compressor building, recycle building, and electrical service control building; installation of all piping and equipment; and testing and commissioning
4. **Completion percentage at time of analysis:** 53 %
5. **Approximate Location:** Southwestern Ontario

3.7.2 Overall and Hourly Category Analysis: First Site Visit

Figure 28 is a pie chart that illustrates the overall activity rates for the first site visit at the DN project.

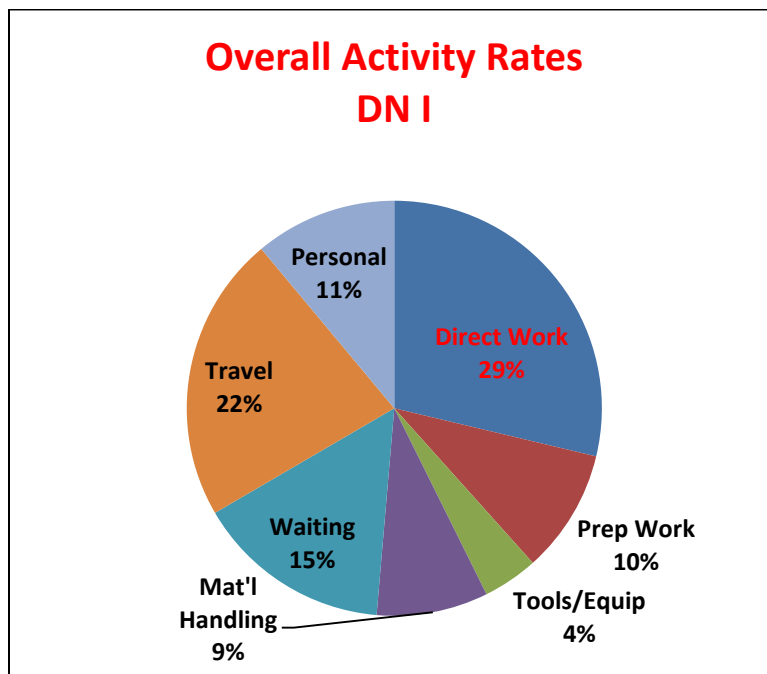

Figure 28: Pie Chart showing overall activity rates, DN I

Figure 29 shows a roller coaster chart of the overall hourly activity rates for the same site visit.

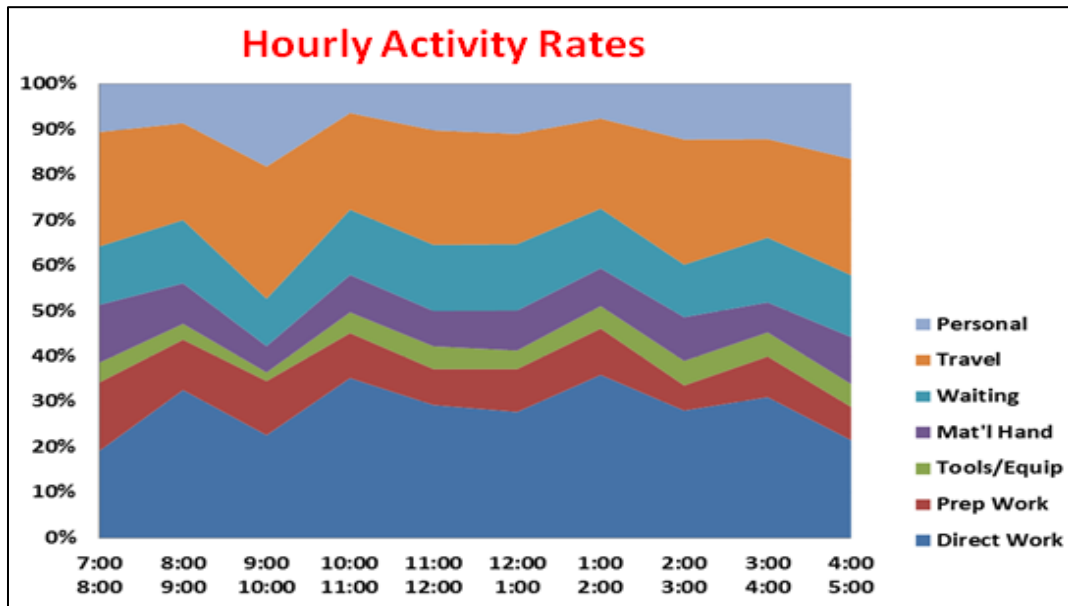

Figure 29: "Roller coaster" chart showing hourly activity rates, DN I

3.7.3 Trade Analysis

Table 5 shows the site information while it has been visited, such as the detail of available trades on site, and temperature for each day.

Table 5: Daily temperatures and trade head-counts, DN I

		07-Jun-11	08-Jun-11	09-Jun-11	10-Jun-11	Work Hours/Day
Temperature		25.6 °C	28.2 °C	19.4 °C	14.7 °C	
#	Trade	# Available on Site	# Available on Site	# Available on Site	# Available on Site	
1	Pipefitters	20	21	22	21	10
2	Civil	14	13	13	14	8
3	Electricians	11	9	11	10	8
4	Operators	3	3	3	3	10
5	Boilermakers	4	4	4	4	10
6	Ironworkers	5	5	5	5	8
Total		57	55	58	57	

Table 6 illustrates the number of observations counted for every category and trade for the first visit to DN site.

Table 6: Total activity observations by trade, DN I

Trade Category	Pipefitter	Civil	Electrical	Operator	Boilermaker	Ironworker	Total
Direct Work	773	284	245	435	256	130	2123
Prep Work	376	87	64	39	97	50	713
Tools/Equip	101	27	29	15	89	57	318
Mat'l Handling	280	139	86	31	65	41	642
Waiting	442	282	81	139	129	53	1126
Travel	664	247	199	238	167	136	1651
Personal	407	140	88	58	68	57	818

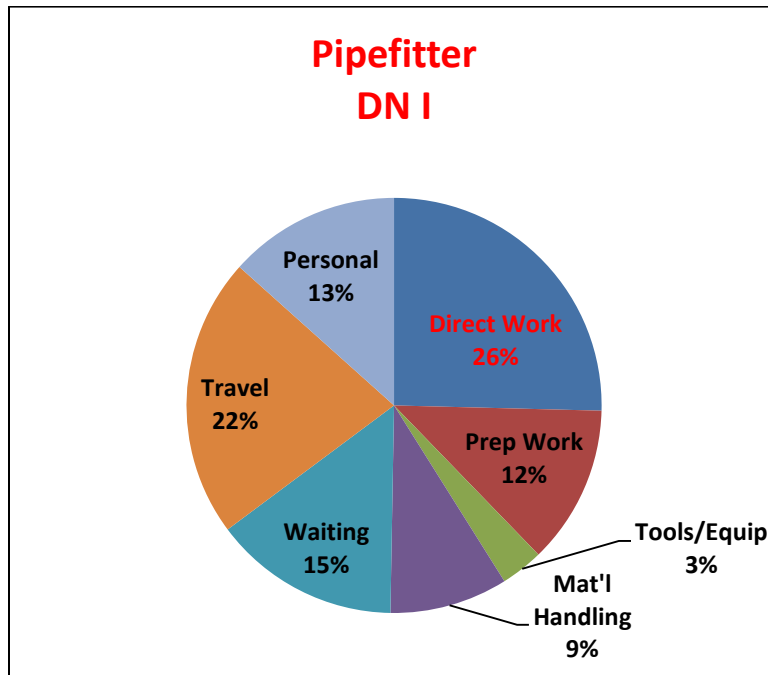

Figure 30: Pipefitter activity rates, DN I

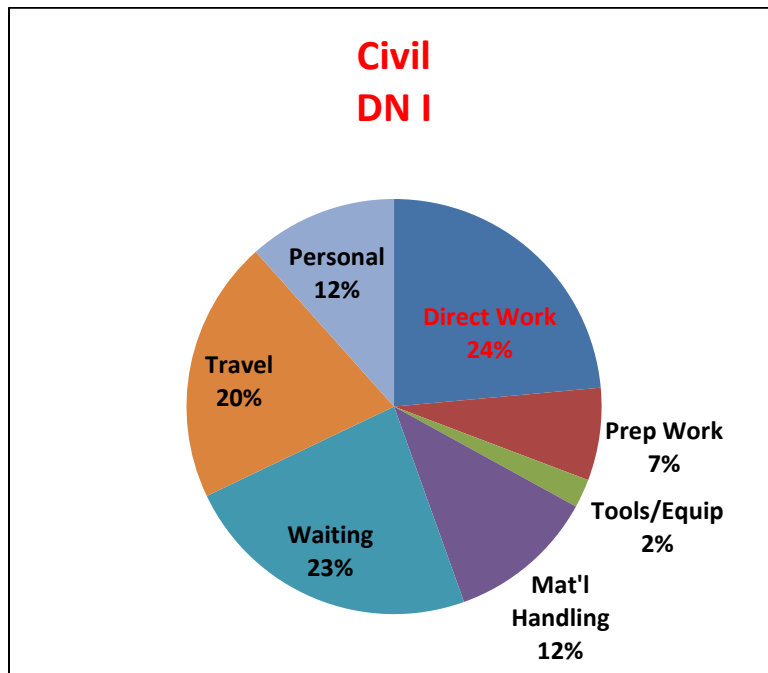

Figure 31: Civil activity rates, DN I

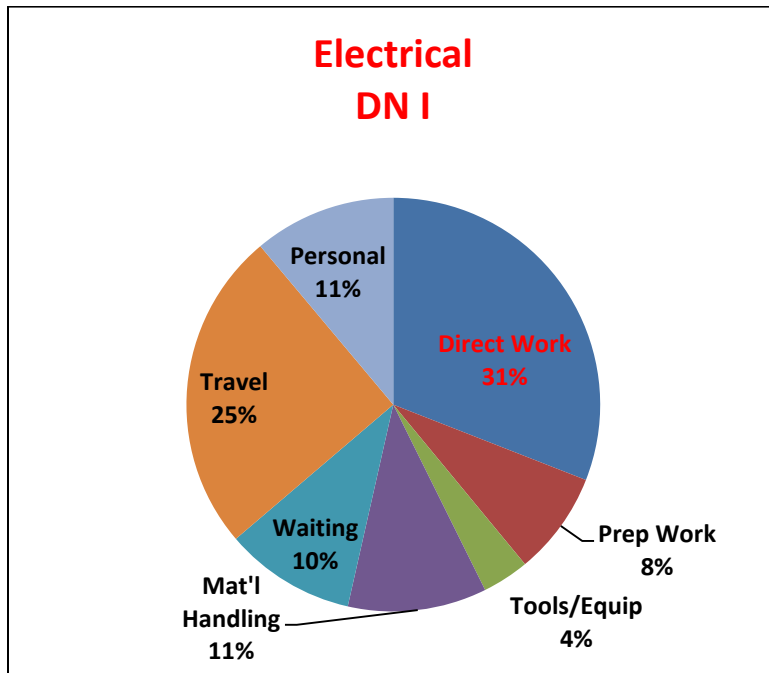

Figure 32: Electrical activity rates, DN I

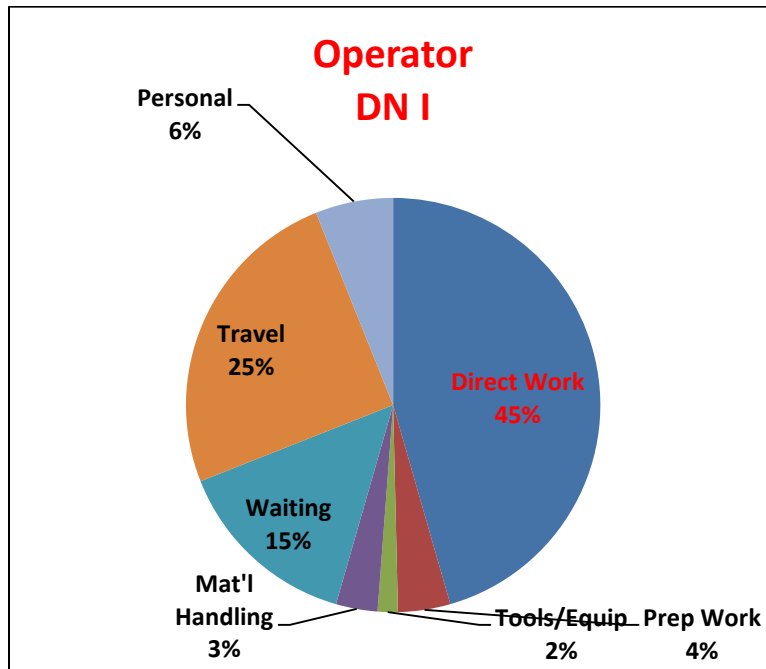

Figure 33: Operator activity rates, DN I

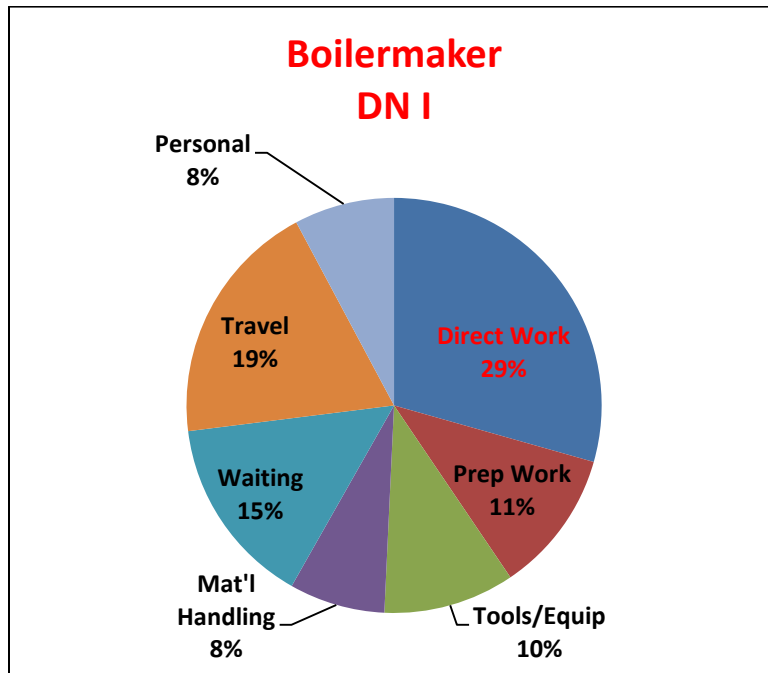

Figure 34: Boilermaker activity rates, DN I

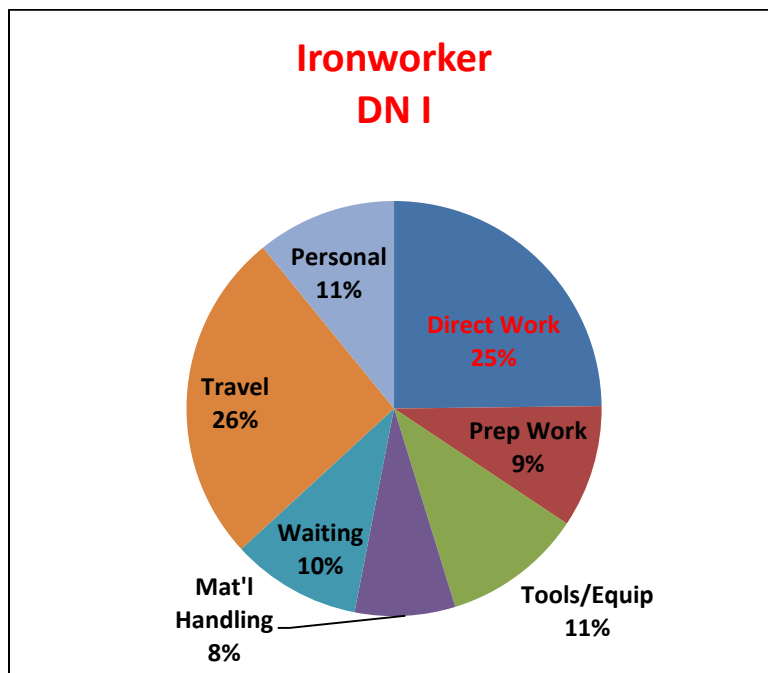

Figure 35: Ironworker activity rates, DN I

3.7.4 Positive and Negative Observations

Positive

1. The trailers, fabrication shop, and break area were in close proximity to most work areas.
2. Breaks and lunch times were taken as scheduled; all craft workers left the site around 12:00 noon and came back at 12:30 pm.
3. A low level of direct involvement or interference by owner inspectors was observed. It should be mentioned that although inspectors were involved, they spent more time in the trailers and less time on site.
4. Washrooms, water, and materials were easy to access.
5. Toolbox meetings ended shortly after 7:00 am, and work would start almost immediately afterwards.
6. No personnel used cell phones while working.

Negative

1. The relatively small site area caused some congestion associated with the fabricated pipe laydown yards.
2. Temporary excavations across multiple roadways made worker and vehicle travel a bit difficult.
3. Some groups of pipefitters spent much of their time on preparation work and waiting for material to arrive, showing a lack of organization.
4. Too much personal time was observed, caused by too many breaks and the large number of smokers on site.
5. Too much travel was observed, caused by the presence of subcontractors' vehicles on site.
6. Although it was a Greenfield site and everyone was working according to the safety regulations, sometimes extraneous signage or barriers were left up when no longer necessary.
7. Initial site design issues created by the owner prior to this project caused rework and delays.
8. Several small excavations with no work taking place were evident, causing unsafe conditions as well as extra travel time.
9. The excessive amount of garbage and material storage that was located in common pathways made traveling difficult.

3.7.5 Recommendations

1. Reduce the number of contractor and subcontractor vehicles on site.
2. Better prepare and organize each trade's work so that they do not spend too much direct work time waiting or preparing work activities. Toolbox meetings are an ideal example of a solution to this problem.
3. Ensure the accuracy and organization of engineered design drawings and fieldwork packages ahead of time in order to decrease rework and delays.
4. Ensure that no unnecessary safety signs or excessive barriers such as storage areas are present in order to reduce travel time, waiting, and delays.
5. Complete in-progress tasks prior to starting new tasks. For example, completed sections should be backfilled.

3.8 DN Project: Second Cycle, Following Implementation

The recommendations were implemented on Tuesday, July 5, 2011. More emphasis was placed on implementing recommendations 1, 2, 4, 5, and 6. To provide ample time for the site to adjust to the changes, the second visit to the DN site took place two weeks after the initial one. From Monday July 18th to Wednesday, July 20, 2011 the site was visited for the second observations and data collection. It should be mentioned that 80 % of the project had been completed at the time of the second visit. During this visit, only four trades were available on site: pipefitters, civil workers, electricians, and operators.

In general, the recommendations were not implemented to an acceptable level on the site. But the impact was still noticeable in a number of activity categories. Communication was lacking between the parties in charge of making the recommendations and the parties in charge of implementing them, as evidenced by such examples as the on-site coordinators not being informed on time, or others in charge of determining tasks that needed accomplished not being updated. This situation caused remaining significant delays and issues throughout the entire process.

3.8.1 Visible Site Changes and Corresponding Advantages

Barriers

- Fewer ground path barriers, such as holes, made it easier for craft workers to travel and move around on site. Also site looked more organized.

- Safety and hazard signs being more organized and better located on required areas. It made travel easier and site more organized.
- Storage areas were better located and not on travel routes. This made storage areas more accessible for craft workers and less travel required.

Vehicles

- Vehicles were used only when necessary, which decreased unnecessary travel.

Personal time

- Personal time, such as that used for smoking, occurred more often during break times and was less scattered throughout the day.

Using time more efficiently

- The operators were able to become more productive in the sense of performing other tasks while waiting for a long-term task.
- The pipefitters were more organized and better prepared in the morning. Hence, a more constant amount of direct work was observed.

3.8.2 Overall and Hourly Category Analysis: Second Site Visit

Figure 36 is a pie chart that illustrates the overall activity rates for the second site visit at the DN project and Figure 37 shows a roller coaster chart of the overall hourly activity rates for the same site visit.

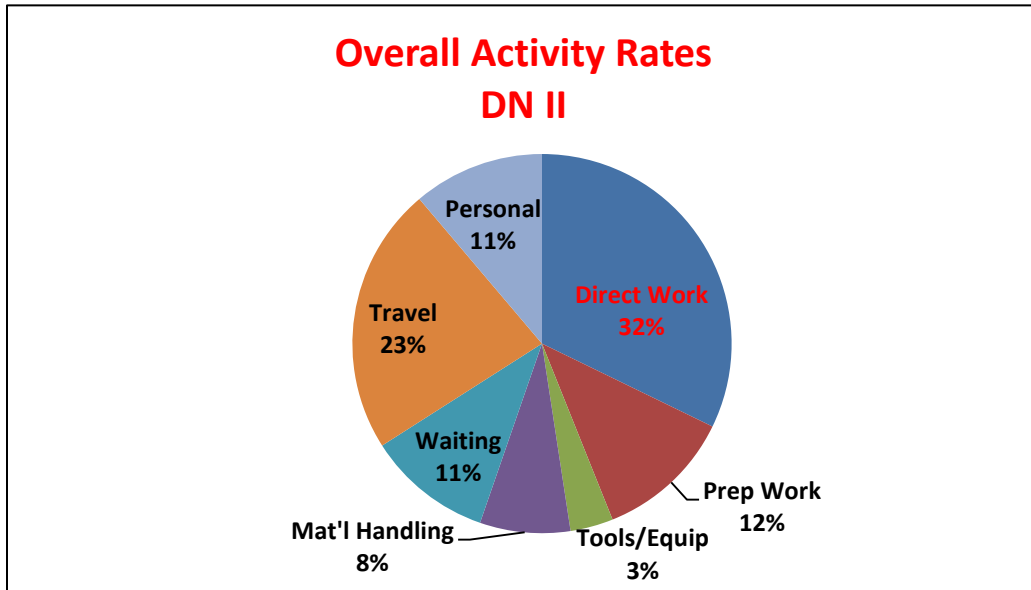

Figure 36: Pie chart showing overall activity rates, DN II

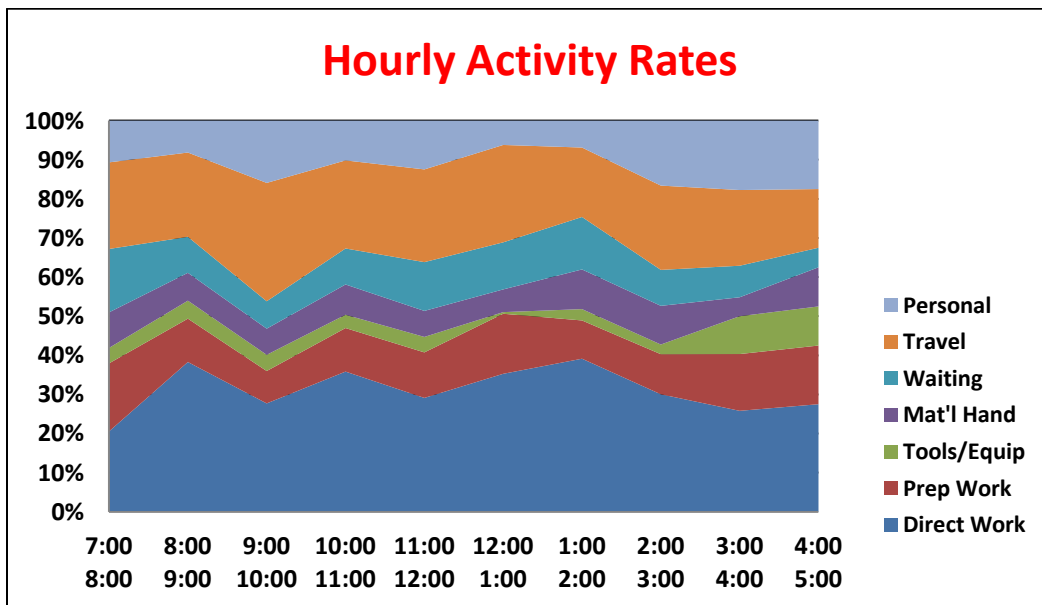

Figure 37: "Roller coaster" chart showing hourly activity rates, DN II

Table 7 shows the site information while it has been visited, such as the detail of available trades on site, and temperature for each day.

Table 7: Daily temperatures and trade head counts, DN II

		18-July-11	19-July-11	20-July-11	Work Hours/Day
Temperature		32°C	27°C	33°C	
#	Trade	# Available on Site	# Available on Site	# Available on Site	
1	Pipefitters	22	22	22	10
2	Civil	13	13	13	8
3	Electricians	10	10	10	8
4	Operators	3	3	3	10
Total		48	48	48	56

Table 8 illustrates the number of observations counted for every category and trade for the second visit to DN site.

Table 8: Total activity observations by trade, DN II

Trade Category	Pipefitter	Civil	Electrical	Operator	Total
Direct Work	463	135	134	183	915
Prep Work	215	31	66	21	333
Tools/Equip	85	8	9	2	104
Mat'l Handling	141	41	27	10	219
Waiting	171	47	28	57	303
Travel	340	137	85	87	649
Personal	185	61	45	27	318

Figures 30-33 are presented for direct comparison with Figures 38-41.

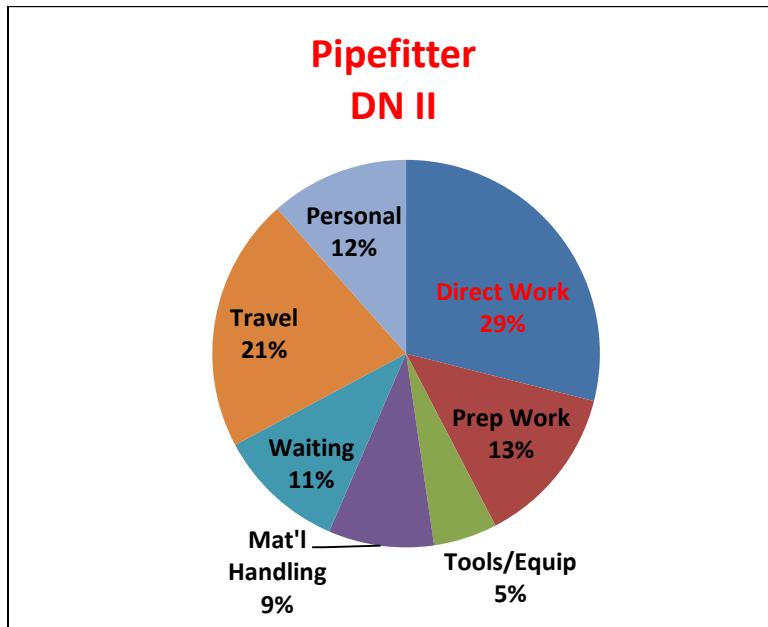

Figure 38: Pipefitter activity rates, DN II

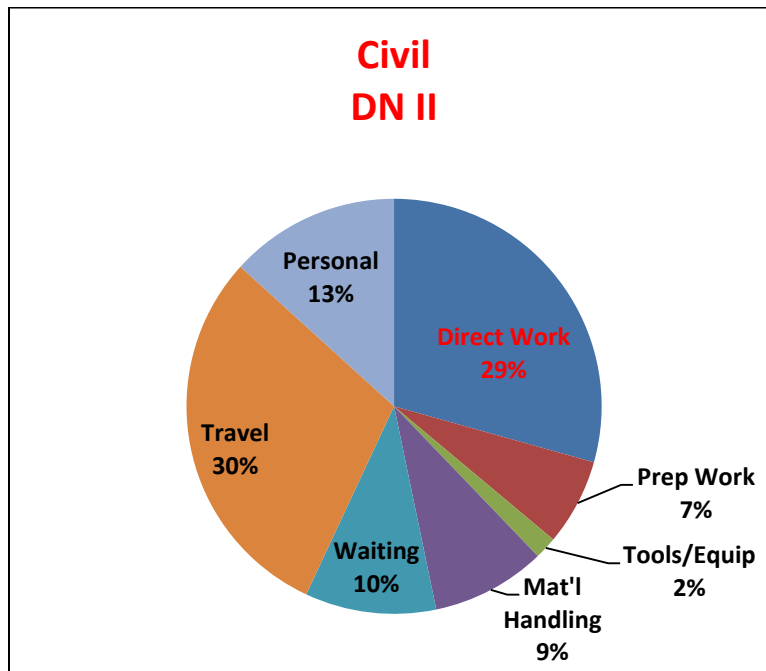

Figure 39: Civil activity rates, DN II

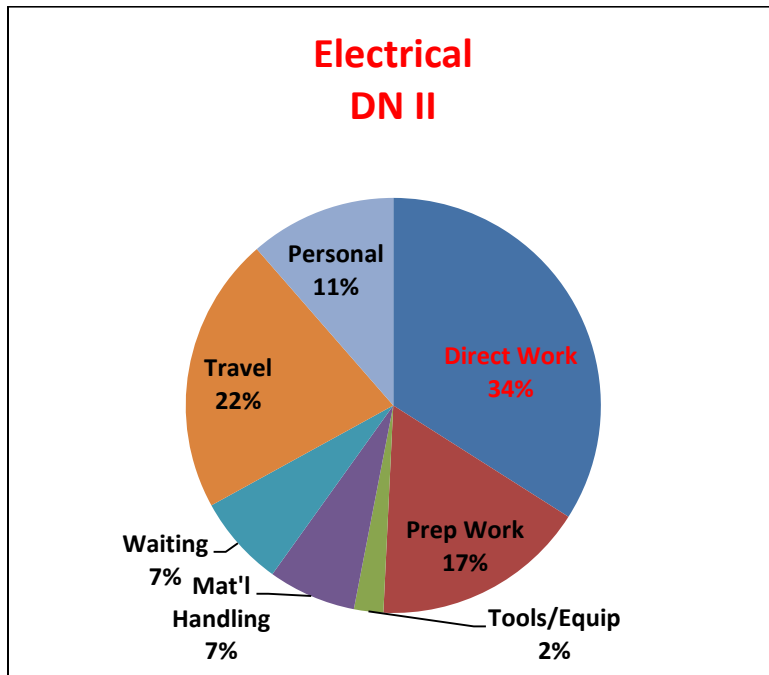

Figure 40: Electrical activity rates, DN II

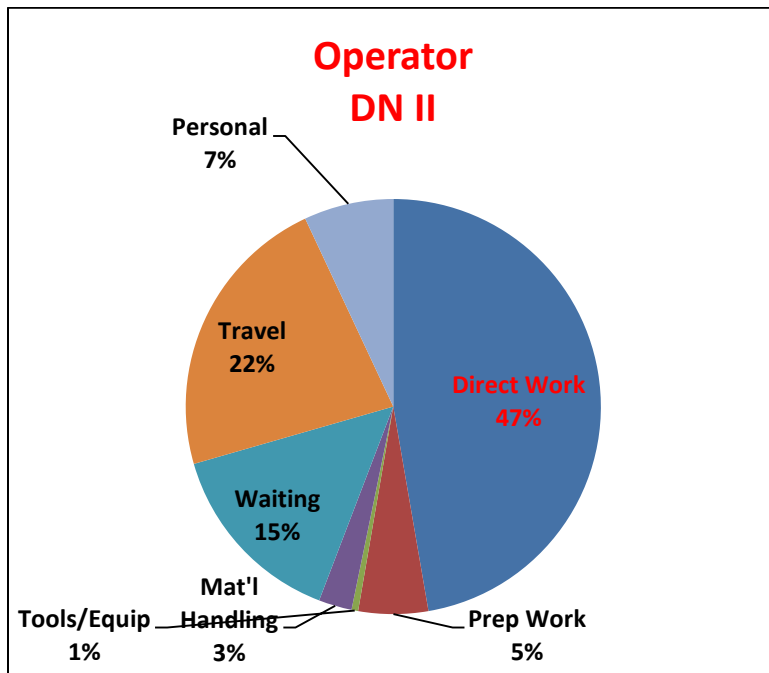

Figure 41: Operator activity rates, DN II

Although two of the six trades were absent for the second cycle analysis, the remaining four trades were compared.

3.9 Comparison of the First and Second Cycles for the DN Project

3.9.1 Same-Trade Activity Rate Comparison: DN (I, II)

Figures 42-45 show a comparison of the activity rates of same trades for cycles I and II of the DN project.

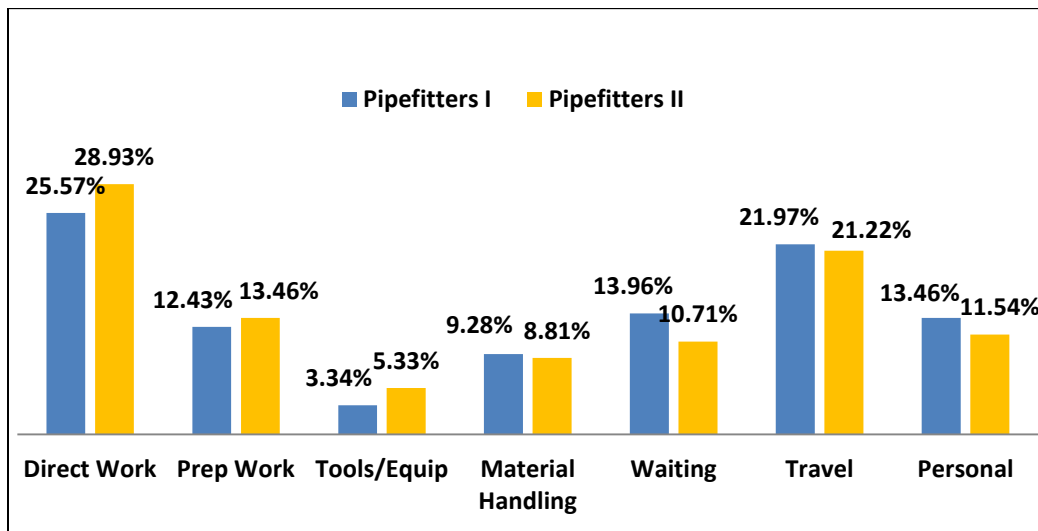

Figure 42: Comparison of the pipefitter activity rates, (DN I and II)

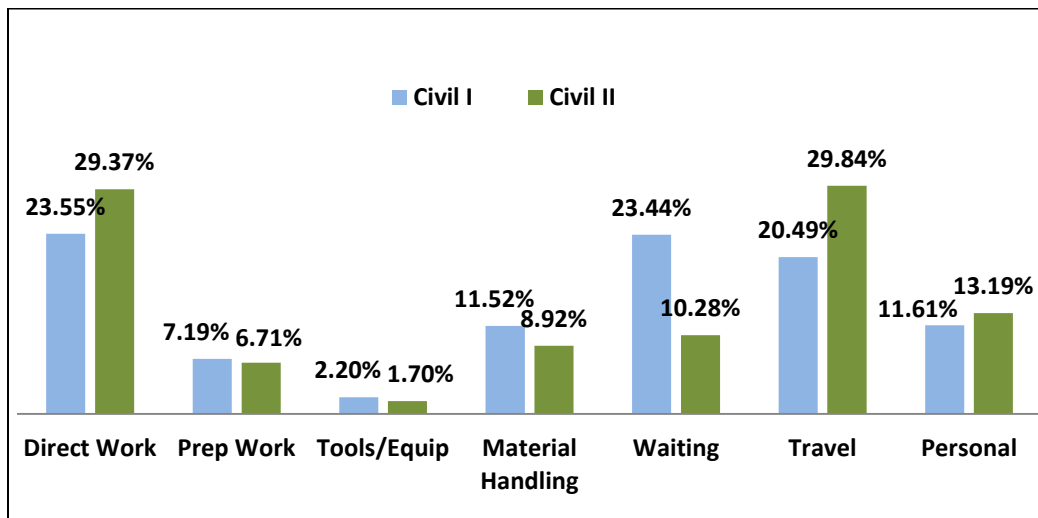

Figure 43: Comparison of the civil activity rates (DN I and II)

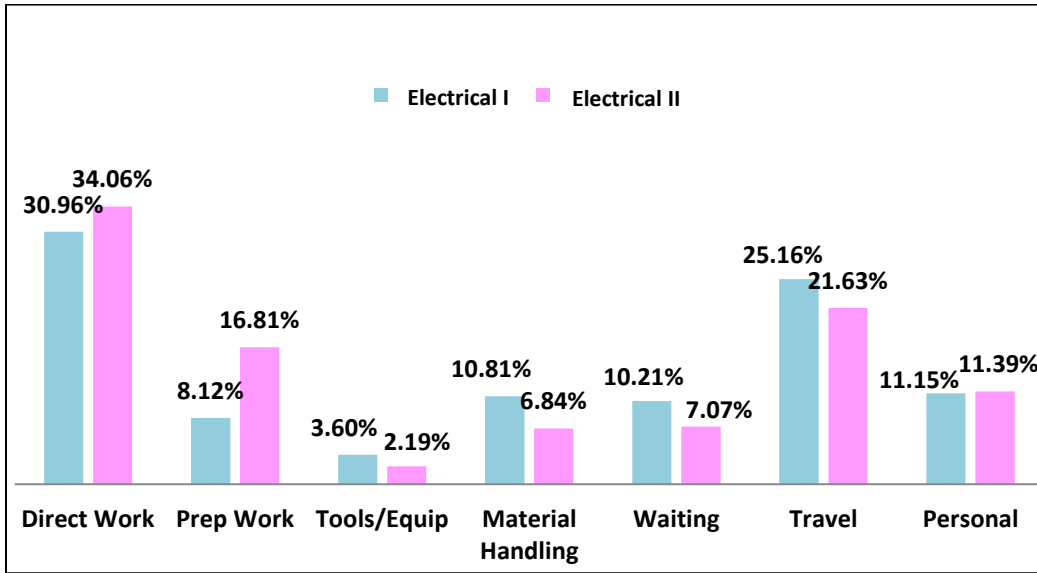

Figure 44: Comparison of the electrician activity rates (DN I and II)

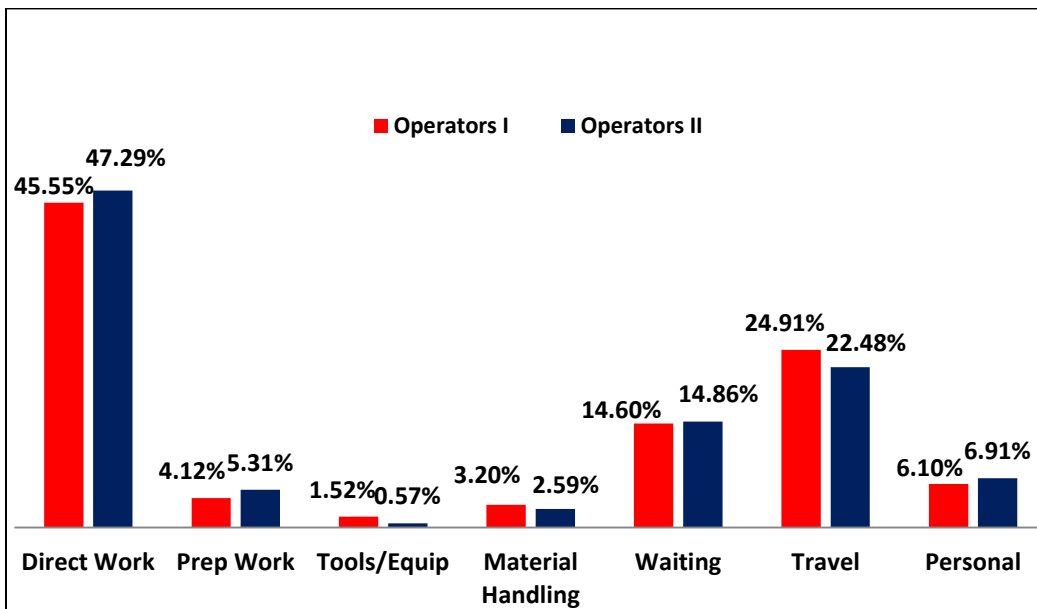

Figure 45: Comparison of the operator activity rates (DN I and II)

3.9.2 Trade Comparison Summary: DN (I, II)

Figures 46-48 show a comparison of activity rates by trade observed during cycles I and II at the DN project.

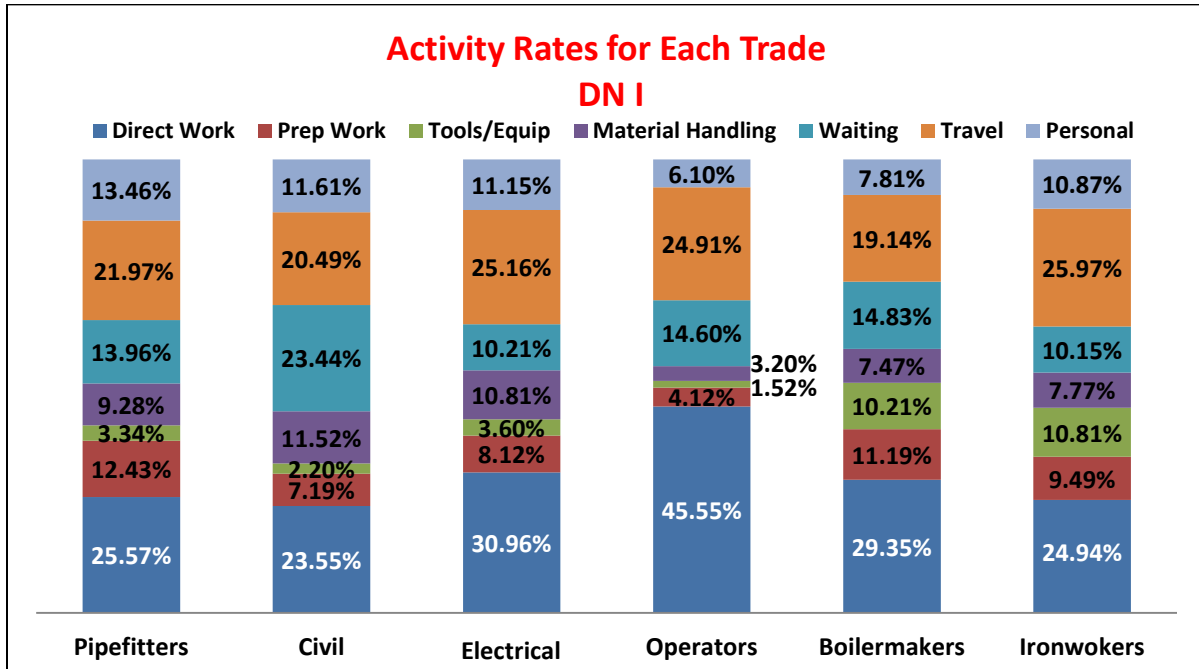

Figure 46: Activity rates per trade, DN I

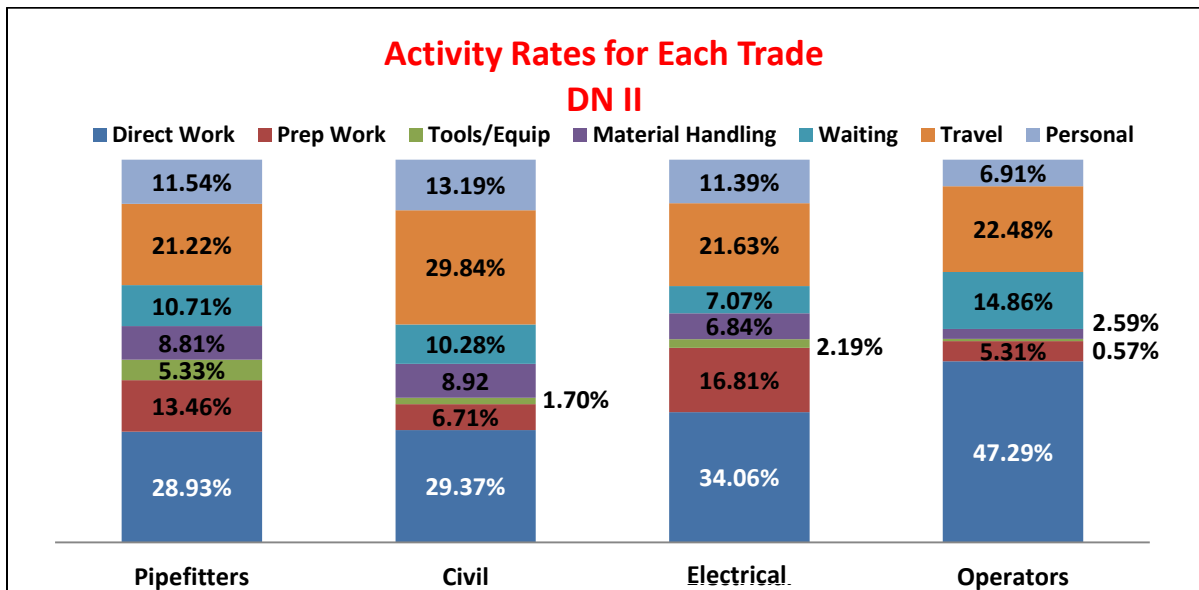

Figure 47: Activity rates per trade, DN II

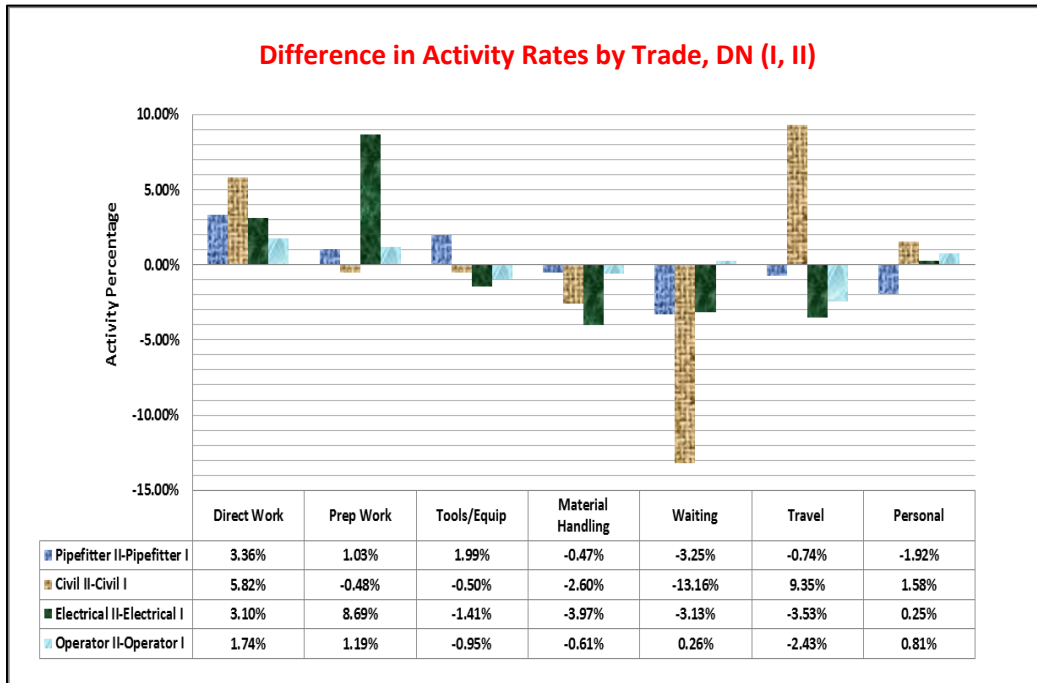

Figure 48: Differences in activity rates by trade, DN (I, II)

Direct Work showed an increase for all four trades: operators, electricians, civil, and pipefitters. Statistics show that this rate is different for each trade. It could be concluded that the complexity of the work is related to the increased rate for each trade. For example, civil work is less complicated, and that direct work rate increased 5.82 %, whereas the rate for pipefitter work, which is more complicated and needs more preparation, increased by only 3.36 %.

Preparation Work exhibited an increase for operators, electricians, and pipefitters but a decrease for civil. One of the causes of the increases could be a higher number of changes in the tasks to complete during the week, which would lead to a greater level of sudden, impromptu planning. Extreme hot weather during the week also would have had a definite influence on the changes in the tasks.

Tools/Equipment showed a decrease for operators, electricians, and civil, but an increase for pipefitters. Overall, it could simply be that less time was spent adjusting tools and equipment on site and that less time was spent moving equipment from one location to another.

Material Handling exhibited a decreased rate for all four trades, which indicates that less time was spent acquiring the appropriate material from the storage area and/or taking it to a specific location to perform a

task. This result could mean that labourers were more prepared in the morning and/or after breaks and had the appropriate material at hand while working on a task. Also it means that the materials required for a task were accessible so that less time was consumed obtaining materials such as small bore pipe. Overall, it can be said that more time was saved acquiring the required materials, with more time also spent installing or welding them, which means that more direct work was performed.

Waiting time decreased overall for all four trades, which is evidence of better planning and preparation both in the morning and in general. It also demonstrates an improvement in the organization of on-site tasks. Less time was spent waiting to perform a task or to be told what needed to be accomplished. It could be said that more time was spent in the constant performance of work with appropriate numbers of labourers.

Travel showed a decrease for all trades except civil. Possible reasons for the increase in this category for this trade can be illustrated by examples such as the movement of materials from one point to another, travel to different job areas during a day, and other factors that were not noticed during the observation and that require additional investigation. For the other three trades, the decrease in travel means that less time was consumed obtaining materials and reaching trailers and task locations. This time saved meant that more valuable tasks could be completed during the day. Less travel also reduces fatigue during the day.

Personal exhibited a minor increase, with only the pipefitters' personal time showing a decrease. Due to the small percentages involved, the changes in the rate for all trades could be neglected, and it can be said that personal time remained unchanged. As a result of extreme hot weather, a lot of time was spent cooling the craft workers. However, as observed on site, less time was consumed for unnecessary breaks, workers took their legitimate breaks during the designated break times, and the trades did not try to make breaks longer than the standard duration. Therefore, lack of change in the rate for personal time can still be considered an improvement.

3.9.3 Overall Activity Rate Comparison: DN (I, II)

Figure 49 illustrates the comparison of overall activity rates for both visits to DN and Figure 50 shows the differences in the overall activity rates for the same site visits.

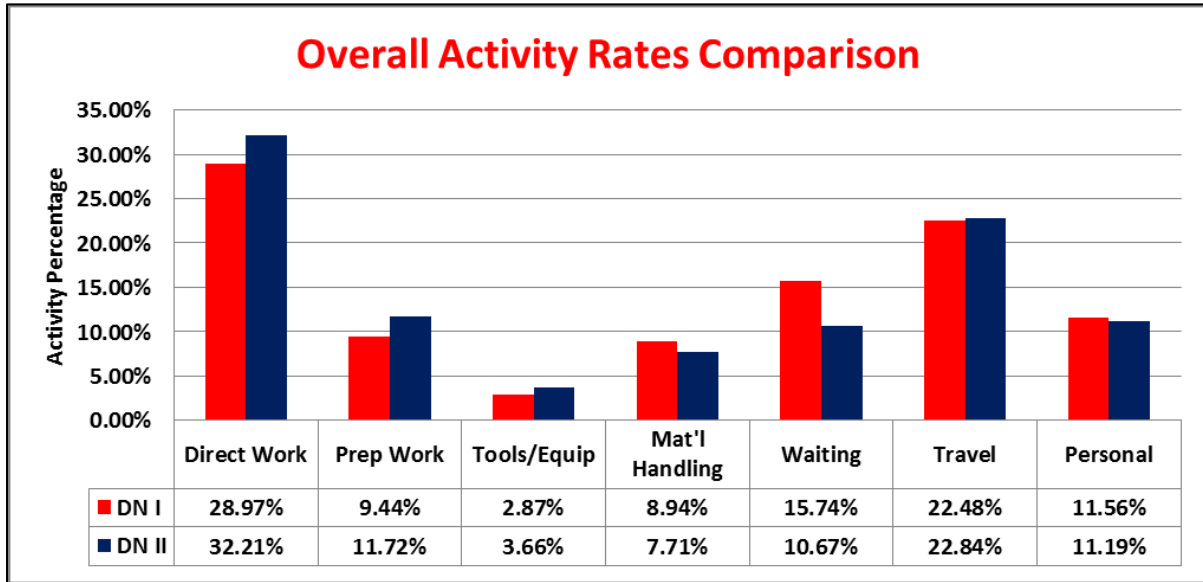

Figure 49: Comparison between overall activities, DN (I, II)

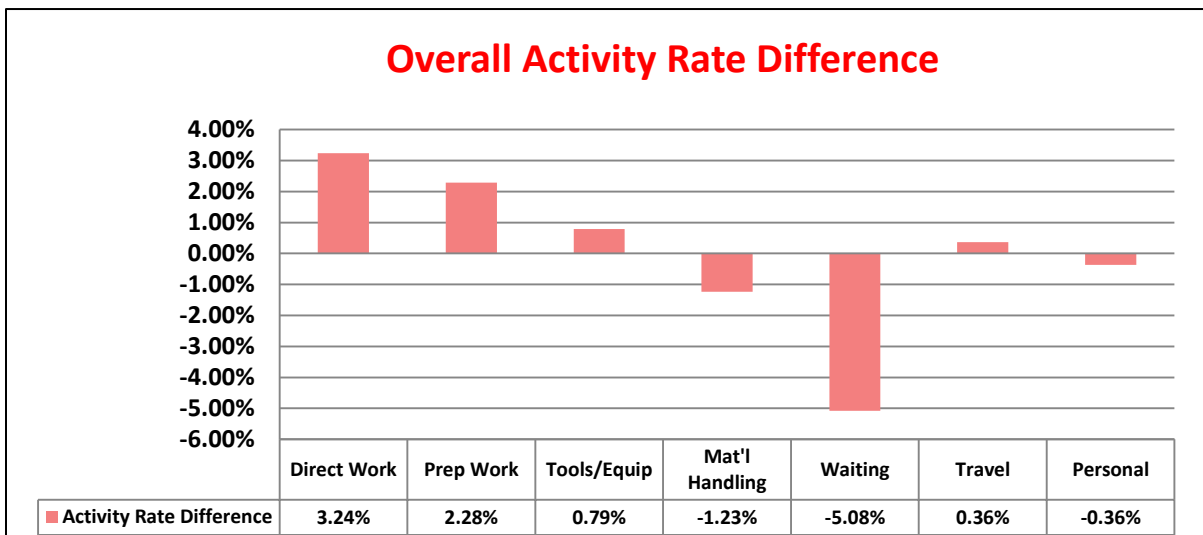

Figure 50: Differences in the overall activity rate, DN (I, II)

Figure 49 shows a comparison of the overall activity rates for both of the DN site visits. In this chart, all of the conditions that might have influenced site productivity for both visits have been considered and nothing was omitted.

As shown in Figure 50, a positive sign indicates an increase, and a negative sign specifies a decrease in a particular activity rate. This figure is based on an equal number of trades being available on site, and therefore neglects boilermakers and ironworkers because the goal was to determine the overall improvement under same conditions.

Based on Figures above 49 and 50, the activity that showed the greatest increase is the direct work rate.

3.10 DN Site Summary

Based on Figure 50, by applying the Activity Analysis tool on DN's site, the overall accomplishment is 3.24 percentage points or an 11 % increase in the preceding direct work rate. Although as mentioned, weather was extremely hot and it had a major impact on site's workflow.

Preparation work increased 2.28 percentage points. A possibility for this increase could be spending more time understanding what needs to be done and to do tasks properly rather than waiting or not working efficiently. Tools and equipment increased 0.79 percentage points. Waiting decreased 5.08 percentage points, which shows a good progress preparing activities ahead of time and not during work hours. Travel increased 0.36 percentage points which is still a good achievement during the unusual situation on site. An increase in travel would be normal as workers needed to go to trailers, washroom, etc. to cool down more often. Similar reasons justify the personal category slightly decreasing with a rate of 0.36 percentage points. It should be mentioned that these percentages are under the actual conditions of each site, and nothing has been neglected while evaluation. For instance, in DN (I) 6 different trades were available while in DN (II) only 4 trades were on site. In this section all this information has been taken into account.

It is important to comment that since a combination of pipefitters, civil, operators and electricians were on site, a unique direct work rate target will be found that lies somewhere between standards for each trade individually. Based on different available articles and papers on how to define and set targets, a direct work rate of 32 % is very good to achieve after two weeks of implementation.

A comparison of Figures 49 and 50, leads to the conclusion that the absence of boilermakers and ironworkers does affect the activity rates, so a quantifiable method of linking their absence to the rate changes needs to be determined.

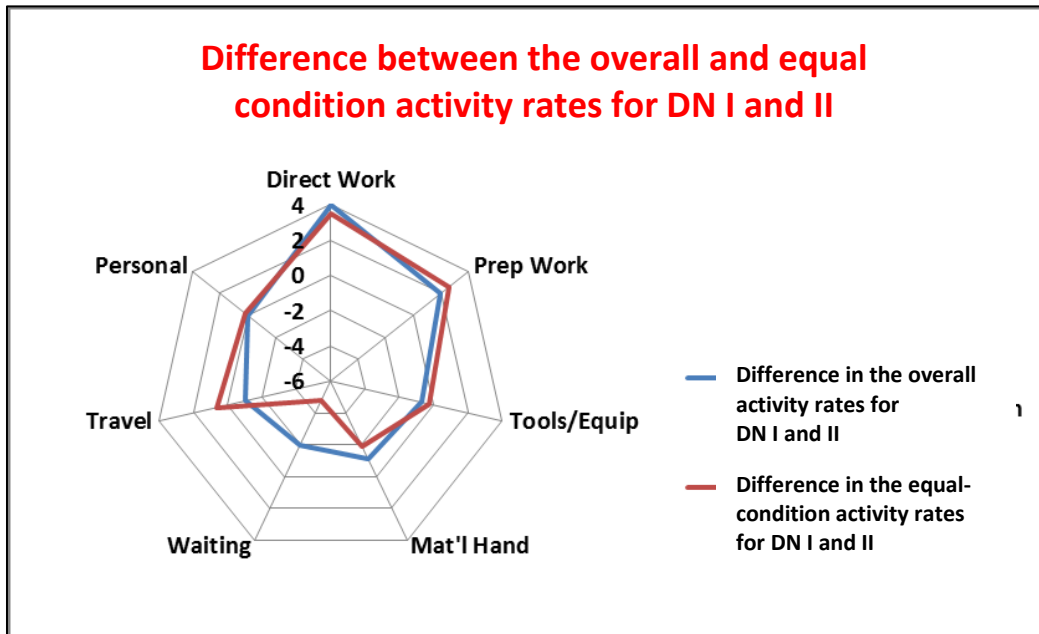

Figure 51: Activity rate comparison between same and all conditions

As shown in Figure 51, a positive sign indicates an increase, and a negative sign represents a decrease in a particular activity rate. Red indicates that the same types of trades were available on site for both visits, thus neglecting boilermakers and ironworkers; blue indicates all trades represented during both visits without neglecting any particular trade or condition, with the goal of determining the overall improvement under both the assumed and the true site conditions. Based on Figure 51, the activity that showed the greatest increase is the direct work rate.

3.11 HN Project

Activity Analysis should be implemented when the construction phase is between 10 % and 90 % complete. At the beginning of a project, a variety of factors affect activity rates, which are not stable and may change as the project proceeds. These factors include the learning curve discussed in the literature review as well as crew mobilization and demobilization. The activity rates obtained may therefore not be accurate values. At the end of a project, when limited time is available, the same arguments may hold so

that Activity Analysis may not be the best option. It is to note that for the ease of work, this project will be identified and presented as “HN” for the rest of chapters. Since the HN project was close to the end, the author had the chance to visit this site only once. It is discussed briefly in order to emphasize the different factors that affect the direct work rate and other activity rates on a site and to indicate an average value for the activity rates of trades available for observation at all three projects.

3.11.1 Site Overview

1. **Project Title:** Waste Water Treatment Plant (WWTP) Upgrade - Bio-gas and Sludge Thickening Building
2. **Project Size:** 4,800 m²
3. **Project type:** Brownfield
4. **Activities:** The major tasks are the completion of the top slab on the building foundation and all of the external piping.
5. **Completion percentage at time of analysis:** 73 %
6. **Approximate Location:** Southeastern Ontario

3.11.2 Overall and Hourly Category Analysis: First Site Visit

Figure 52 is a pie chart that illustrates the overall activity rates for the first site visit at the HN project.

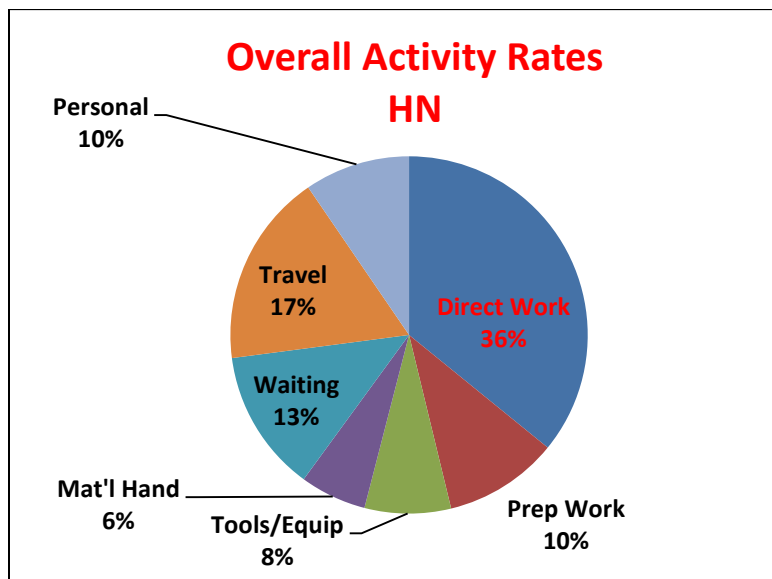

Figure 52: Pie chart showing overall activity rates, HN

Direct Work showed a 36 % rate, which is a weighted average of all three trades. This rate could be considered good, given that many changes and unexpected stages of work were occurring during the sampling. However, it is slightly misleading since rates for operators can be very high (>45 %), so the other trades may not be as productive as they seem. It should be mentioned that the direct work rate for each trade should be evaluated with its own individual target or acceptable direct work rate.

Preparation Work exhibited a 10 % rate, which is slightly low; more planning before major tasks throughout the day could improve the direct work rate by eliminating confusion and mistakes.

Tools/Equipment showed an 8 % rate, which demonstrates that a fair amount of time was being spent in this category. Little time for direct work activities is likely to be lost here.

Material Handling was measured at a 6 % rate, and as with tools and equipment, this rate could be expected to be higher; therefore, a minimal increase in direct work activities can be created in this area. Another consideration is that there may have been a subtle lack of materials on site during the sample time, which would indirectly pull down direct work rate productivity by redistributing the expected material handling time to unproductive activities such as waiting or personal.

Waiting showed a 13 % rate, which should be reduced if possible. A large part of this activity was observed when workers were waiting for the tower crane to transport materials and scaffolds.

Travel exhibited an 18 % rate, which makes this category somewhat high. As with many sites, travel can be the most flexible rate to transform into a more productive activity. Much of the travel observed occurred just after break and lunch times.

Personal should generally show a rate below 10 %; however, this level is not extremely negative. Depending on the worker culture, the direct work rate could be improved if workers are adequately rested, hydrated, and engaged with fellow workers. In this case, to improve the direct work rate, very minor reductions should be the goal in this category.

Figure 53 shows a roller coaster chart of the overall hourly activity rates for the same site visit.

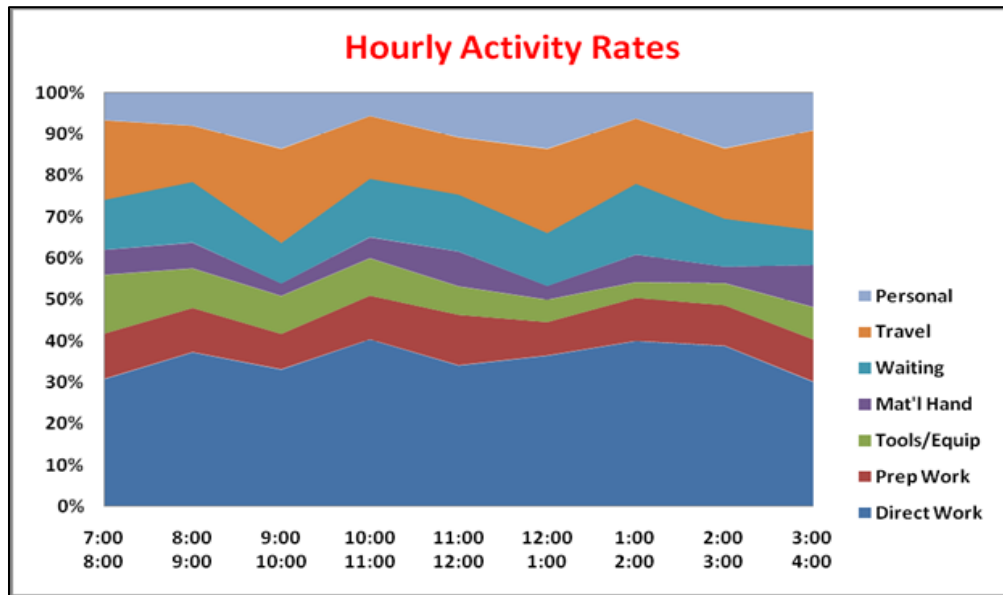

Figure 53: "Roller coaster" chart showing overall hourly activity rates, HN

3.11.3 Trade Analysis

Table 9 shows the site information while it has been visited, such as the detail of available trades on site, and temperature for each day.

Table 9: Daily temperatures and trade head counts, HN

		25-July-11	26-July-11	27-July-11	Work Hours/Day
Mean Temperature		22.6 °C	20.7 °C	20.8 °C	
#	Trade	# Available on Site	# Available on Site	# Available on Site	
1	Pipefitters	3	3	3	8
2	Civil	14	14	14	8
3	Operators	4	4	4	8
Total		21	21	21	

Table 10 illustrates the number of observations counted for every category and trade for the HN project.

Table 10: Total activity observations by trade, HN

Trade Category	Pipefitter	Civil	Operator	Total
Direct Work	57	377	186	620
Prep Work	25	129	25	179
Tools/Equip	20	112	3	135
Mat'l Handling	2	102	0	104
Waiting	27	148	48	223
Travel	38	244	21	303
Personal	20	136	9	165

The observation totals are nearly proportionally equal to the head counts, with slightly more observations for operators versus pipefitters due their greater visibility. The weather was good with only slightly hot temperatures, which indicates that the weather does not provide an explanation of a lower direct work rate.

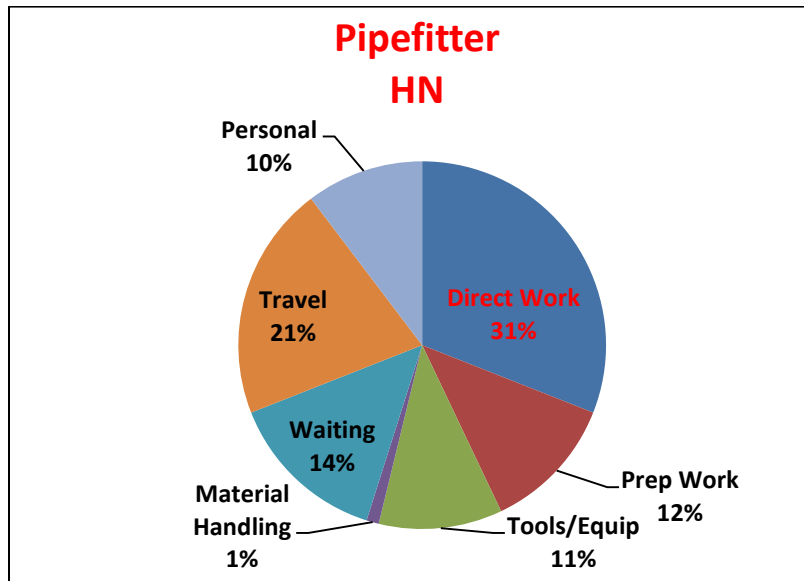

Figure 54: Pipefitter activity rates, HN

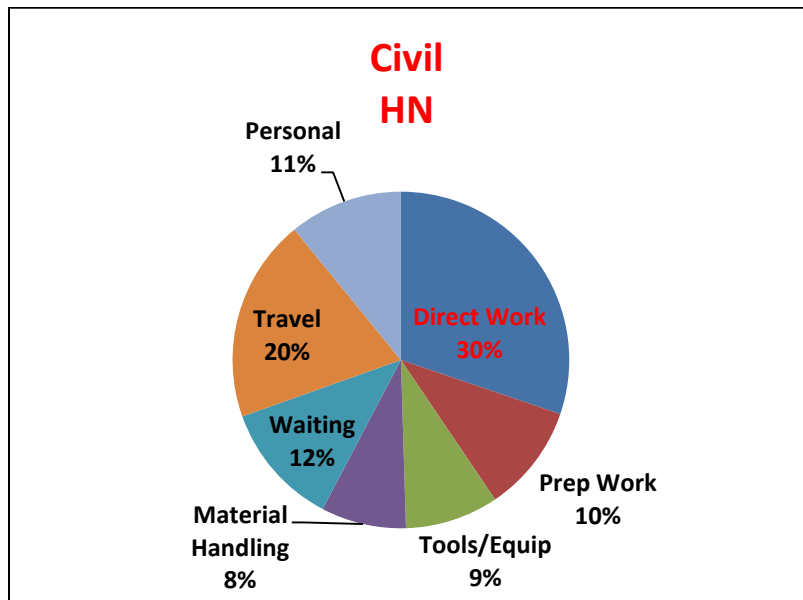

Figure 55: Civil activity rates, HN

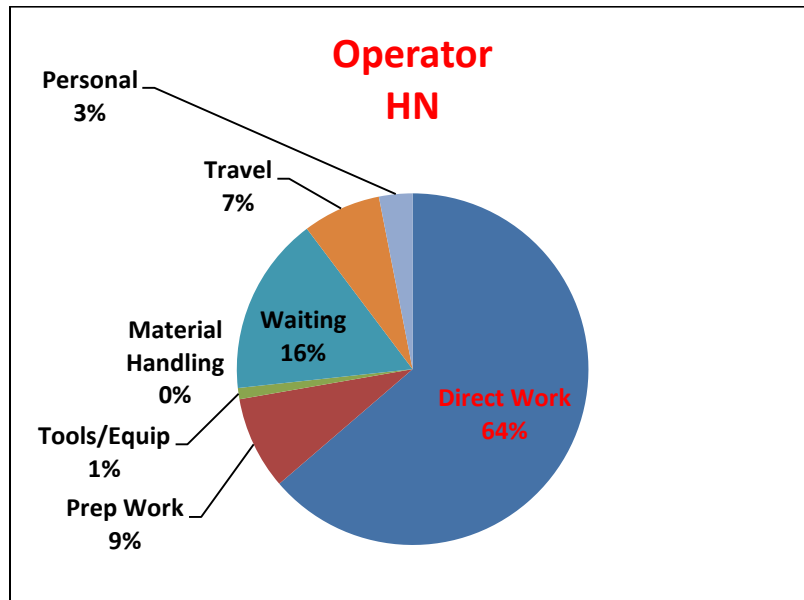

Figure 56: Operator activity rates, HN

3.11.4 Positive and Negative Observations

Positive

1. A good geographical spread of workers across the site caused less congestion.
2. All workers started work promptly at approximately 7:10 following a 7:00 toolbox meeting. Official meetings were scheduled only for Tuesdays, with others added as needed. The direct work rate was adequate from 7:00 am to 8:00 am, and fewer craft workers were scattered during that time.
3. Critical tasks, such as the delivery of concrete to be poured, were addressed during the scheduled break time.
4. A few instances of a general commitment to working a few minutes into break/lunch times were observed.

Negative

1. The large amount of flexibility in the timing of breaks seemed to cause extended periods of personal time. In some cases, workers were waiting for others; for example, some would break from work between 9:35 and 9:50 as scheduled, but other workers would be waiting from 9:30-9:35 as well.

2. Inaccurate as-built information led to mistakes during the excavation. Incidents involving pipes breaking led to delays and rework.
3. Specific groups would always be found waiting for overhead crane assistance. One subcontractor's designated labourers were observed to be working excessively hard, and other subcontractor's groups needed to wait for materials.
4. No accessible pathway was available on the west side of the foundation, causing an increase in on-foot travel from the northwest corner to south-end trailers and materials.

3.11.5 Recommendations

1. Encourage workers to time-block tasks so that they reach small completions just before break time. This change should reduce the effect of a few workers taking a delayed break (e.g., 9:40-9:55), resulting in other workers stretching their break to match (e.g., 9:30-9:55) and deeming the first few minutes of the scheduled break time not "official."
2. Put the crane on a 10-hour day and use the final 1-2 hours to perform drops of materials for the beginning of the next day to be ready when the workers return.
3. Install scaffolding on the west side of the foundation to allow more efficient travel.

3.12 Overview of Data Collection at the Three Sites

Figure 57 illustrates the comparison of individual trade activities at all projects.

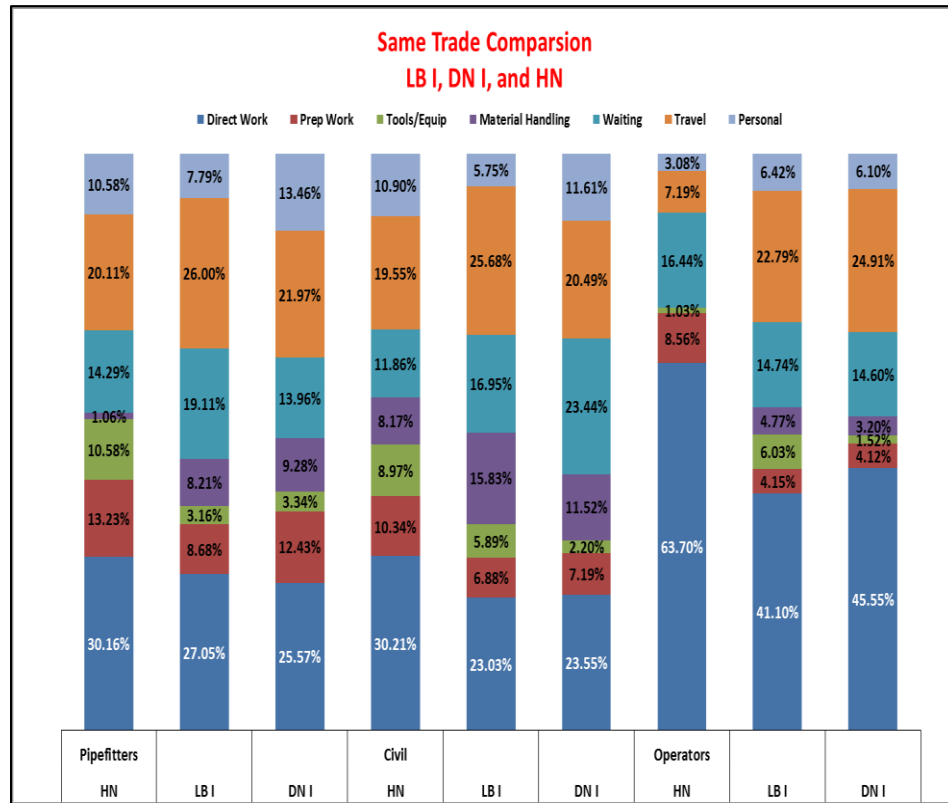

Figure 57: Comparison of individual trade activities, LB I, DN I, HN

In Figure 57, the percentages for each site are listed above the seven categories for each trade. These percentages incorporate all conditions on all sites, and nothing has been omitted. It should be noted that the DN and HN sites had more trades available, which have been included in the calculations for the overall category percentages. To make the comparison equivalent and consistent for the trades and to indicate the trends in the trades in the figure, the activities for the LB and DN sites were evaluated based only on the first cycle.

Figure 58 illustrates the combined average activity rates by considering same trades at LB I, DN I, and HN projects.

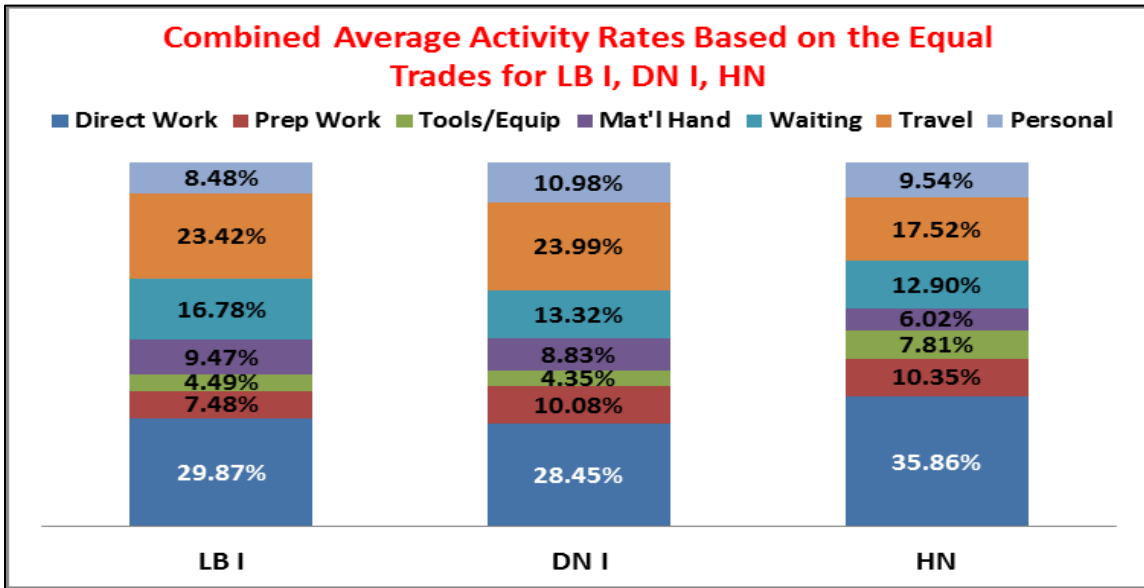

Figure 58: Combined average activity rates, LB I, DN I, HN

It should be noted that overall, the pipefitters, operators, and electricians are roughly on target, with civil below target for a number of reasons, such as the number of workers available on site, the fact that they came from different subcontractors, the locations of the tools and equipment, the skill level of the workers, and the complexity of the tasks.

Figure 59 shows the comparison of overall average and equal trades for activity rates at LB I, DN I, and HN projects.

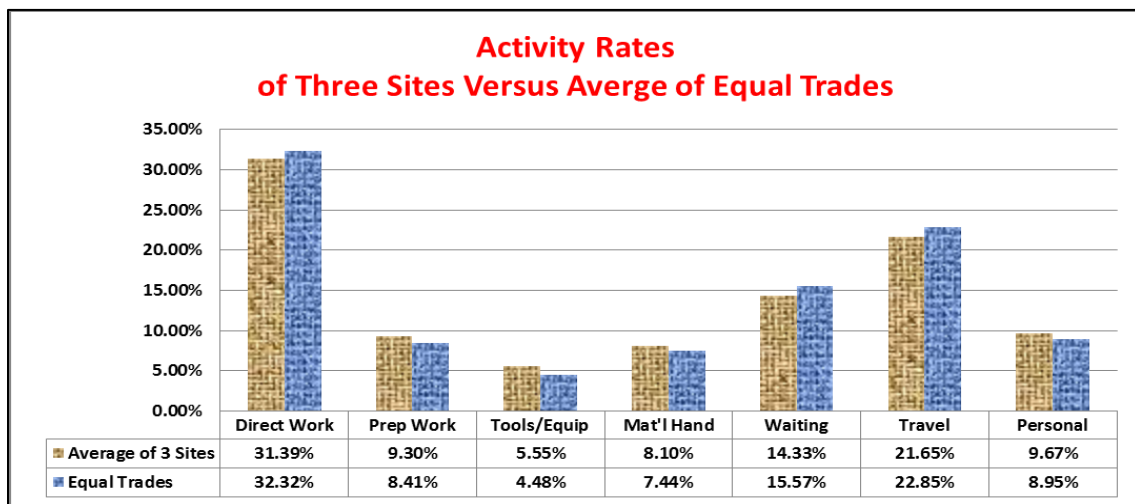

Figure 59: Comparison of activity rates for the overall average and for equal trades, LB I, DN I, HN

Assuming that the same trades are available on each site,

Figure 59 indicates that, as the number of projects increases, the overall activity percentages become more similar. It should be mentioned that the activity rates for each trade and the number of trades available on a site vary from one project to another. As shown in Figure 60, this difference is quite small and therefore insignificant.

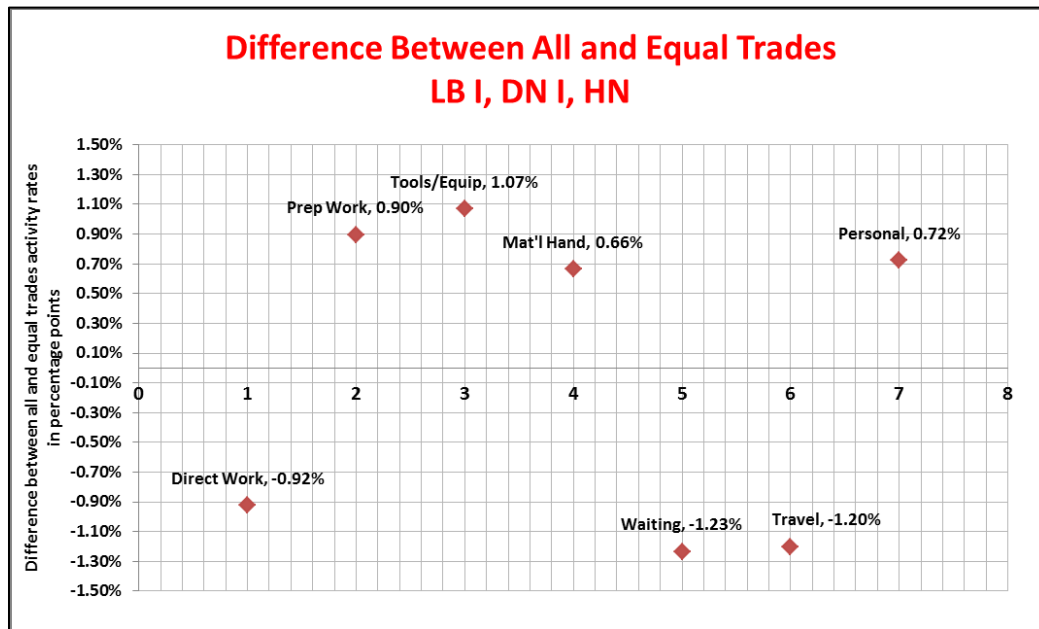

Figure 60: Difference between all and equal trades, LB I, DN I, HN

From Figures 59 and 60, it could be concluded that since the difference is negligible, the same trades from different site jobs can be roughly compared with one another.

As discussed in the literature review, the target rate for different categories depends on a variety of factors, including the project type, the stage of the project, the number of times the site has been visited, the type of trade, the weather, the complexity of the work, the location, and the workers' skill level. If these factors are taken into consideration, it is clear that each trade for each project requires an individual target rate. For an accurate comparison, the ideal case would be that all conditions are equivalent. Therefore, the key to covering as many of the above factors as possible is to produce a database for each site, so that the crew's work trend can be understood and so that, ultimately, a comparison and estimation of the trade's workflow would be possible. The end goal would be to optimize the direct work rate for all craft workers and to minimize unnecessary activities.

Chapter 4: Target Rate Evaluation

4.1 Introduction to Data Analysis

The goal of this research was to describe a practical approach to setting target rates for direct work as well as for other activity categories. A variety of methods could potentially solve this problem, and it might not be possible to determine which one works best unless different alternatives are taken into consideration. To achieve this goal, a plan must first be developed that defines the problem and outlines how the procedure should be implemented. To make timely and well-founded decisions, gathering the data and storing them primarily as a database is important. Since many issues should be thought through for any exploratory data analysis or data mining project, following a predefined process ensures that all issues are addressed and that appropriate steps are taken (Myatt, 2007).

Any exploratory data analysis or data mining project should therefore include the following steps (Myatt, 2007):

1. *Problem definition:* It is important to identify the problem in sufficient detail, in terms of both how the questions will be answered and how the solutions will be delivered. A plan should outline the objectives and deliverables along with a time line and budget for accomplishing the goal.
2. *Data preparation:* Prior to starting any data analysis or data mining project, the data should be collected, characterized, cleaned, transformed, and portioned into a format appropriate for further processing.
3. *Implementation of the analysis:* On the basis of the information from steps 1 and 2, appropriate analysis techniques should be selected, and often these methods need to be optimized. Any task that involves making decisions based on data falls into one or more of the following main categories:
 - a. Summarizing the data
 - b. Finding hidden relationships
 - c. Making predictions
4. *Deployment of results:* The results from step 3 should be communicated and/or deployed into a pre-existing process.

Following the above sequence involves interaction between the steps. For example, it may be necessary to return to the data preparation step when the data analysis is being implemented in order to make the modifications based on lessons learnt.

Finding the appropriate analysis method requires choosing the right technique from the various techniques available for summarizing the data, finding hidden relationships, and making predictions.

Figure 62 illustrates data analysis tasks and models.

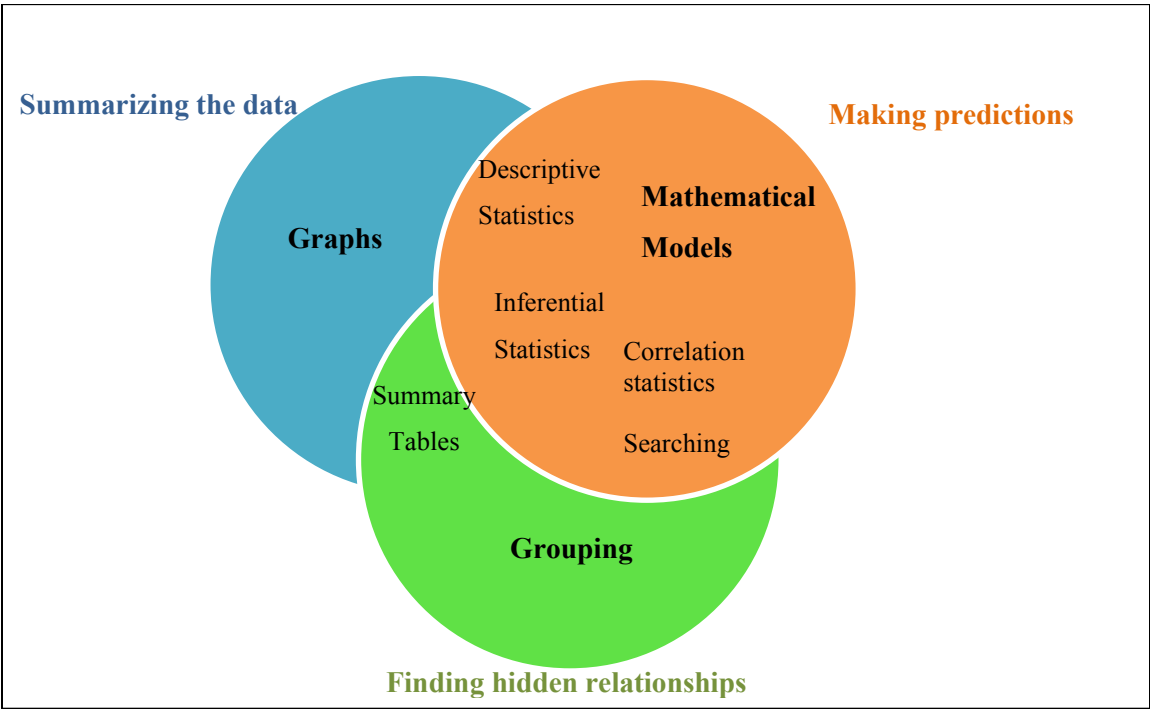

Figure 61: Data analysis Tasks and Models (Myatt, 2007)

4.2 Data Resources

Fourteen sets of data points were collected for this research. Data were included from eight US projects that were part of other author’s previous work on Activity Analysis, data from three projects (five sets of data) were available from the author’s current site visits, and one set of data points designated OG was taken from Oglesby’s (1989) work. So that sequences could be followed more easily, all data were summarized as shown in Table 11. Each project is discussed in detail in this chapter.

It is worth mentioning that all the data were collected based on the *Activity Analysis Guide* (Gouett et al., 2012). Craft workers from each trade were observed on an hourly basis during their typical daily activity. Each separate observation was taken instantaneously and on specific, randomized routes throughout the day. The workers’ activities were classified as belonging to one of seven categories: direct work, preparation work, tools and equipment, material handling, waiting, travel, or personal.

Table 11: Overall activity percentages

Project Category	A	B	C	D	E	F	ID	FR	OG	LB1	LB2	DN1	DN2	HN
Direct Work	27.00%	31.00%	42.00%	28.00%	30.00%	28.00%	20.00%	48.00%	36.07%	30.00%	37.00%	29.00%	32.00%	36.00%
Prep Work	11.00%	13.00%	13.00%	16.00%	8.00%	11.00%	18.00%	11.75%	14.55%	7.00%	9.00%	10.00%	12.00%	10.00%
Tools/Equip	19.00%	8.00%	12.00%	12.00%	7.00%	11.00%	9.00%	8.85%	10.96%	5.00%	6.00%	4.00%	3.00%	8.00%
Mat'l Handling	9.00%	4.00%	2.00%	4.00%	5.00%	8.00%	3.00%	6.10%	7.35%	9.00%	7.00%	9.00%	8.00%	6.00%
Waiting	12.00%	15.00%	11.00%	16.00%	20.00%	14.00%	19.00%	8.46%	10.49%	16.00%	12.00%	15.00%	11.00%	13.00%
Travel	17.00%	16.00%	13.00%	13.00%	24.00%	23.00%	22.00%	11.43%	14.17%	25.00%	20.00%	22.00%	23.00%	17.00%
Personal	5.00%	13.00%	7.00%	11.00%	6.00%	5.00%	9.00%	5.11%	6.34%	8.00%	9.00%	11.00%	11.00%	10.00%
Total	100%	100%	100%	100%	100%	100%	100%	100%	100%	100%	100%	100%	100%	100%

The number of data points available may be insufficient for the statistical validation of any target rate or of the procedure. However, as shown in Table 11, based on an average of the 14 sets of data points, the working hours during a day may be broken down as shown in Figure 62.

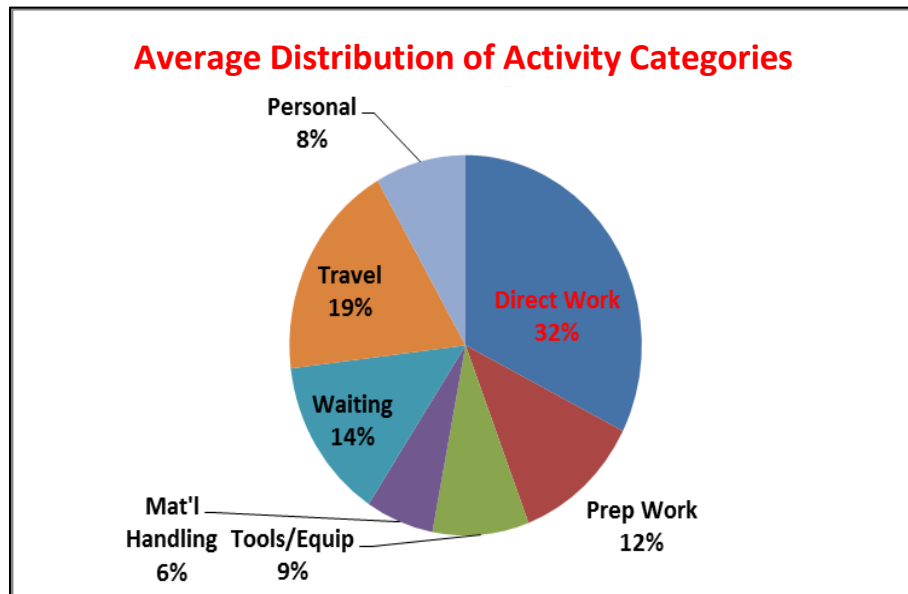

Figure 62: Overall average of each activity category

Figure 62 represents a rollup of all the data available from different locations in the United States and Canada for all the craft workers observed: pipefitters, electricians, civil workers, boilermakers, ironworkers, operators, etc. As the figure shows, on average, 32 % of the total time is utilized for direct work; 12 % is spent preparing the tasks to be accomplished during working hours; 9 % of the time is used for adjusting equipment and for moving tools; 6 % of the time is dedicated to material handling; and 14 %, 19 %, and 8 % are spent on waiting, travel, and personal time, respectively.

Based on previous work on activity sampling (Oglesby, 1989), all categories can be consolidated into three major categories: direct, or effective, work; contributory work, which includes prep work, tools and equipment, and material handling; and idle time, which includes waiting, travel, and personal. According to this classification, only 32 % of the total time is spent on direct work, 27 % of the time goes to contributory work, and 41 % of the time is expended on idle time. This big-picture view provides a good understanding of the necessity for improving the direct work rate, decreasing the unnecessary activity categories, and defining a target rate in order to determine the goals to be achieved.

As discussed previously, the target rate must be defined based on the different trades, the weather conditions, the site location, the complexity of the work, and other factors that affect the crew's work on site. The next section presents two models developed as a means of determining an acceptable target rate.

4.3 Target Rate Models

Different models are appropriate for evaluating suitable target rates for different categories. Unfortunately, insufficient data is available for statistically validating any of the models discussed below. It is worth mentioning that methods have been developed for setting target rates based on experience. These approaches are discussed in the next section, and at the end of the chapter a model for defining an appropriate procedure for estimating acceptable set target rates is introduced.

4.3.1 Approaches to Setting Target Rates

A statistically validated target rate model should be a function of all of the factors that affect labourers' activities on site.

$$F(x) = f(\text{craft, project type, project complexity, weather, etc.})$$

These factors need to be organized in a chart, with a specific weight or multiplier being applied for each condition, based on experience. Depending on the data available and the requirements for the desired target rate, the chart may be more or less detailed.

Table 12 shows an appropriate chart structured for such purposes.

Table 12: Standardizing factors affecting labourers' work on site

Activity Code- Description		Temperature Code -°C		Trade Code- Type		Day of Week Code		Shift Code	
Dw	Direct work	T1	-35 and below	PF	Pipefitter	M	Monday	1	First
Pw	Prep work	T2	-35 to -20	EC	Electrician	T	Tuesday	2	Second
TE	Tools/Equip	T3	-20 to -5	CL	Civil	W	Wednesday	3	Third
MH	Mat'l Handling	T4	-5 to 10	OP	Operator	Th	Thursday	Schedule Code- # Days, Hours	
W	Waiting	T5	10 to 25	BM	Boilermaker	F	Friday	SE1	5-10's
T	Travel	T6	25 to 35	IW	Ironworker	Sa	Saturday	SE2	6-10's
P	Personal	T7	35 and above	-	Etc.	Su	Sunday	SE3	5-8's
Site Condition Codes									
Precipitation Code- Condition		Location Code, Canada		Indoor/Outdoor Code		Working Condition- Code		Ground Condition- Code	
		NP	No precipitation	BC	British Columbia	ICO	Indoor-congested	A	Normal
LR	Drizzle/ Light Rain	AB	Alberta	ICL	Indoor- Clear	B	Elevated	2	Dry/ Hard Soil
SR	Steady Rain	SK	Saskatchewan	OCO	Outdoor- Congested	C	Below Ground	3	Shallow Soil
HR	Heavy Rain/ Storm	MB	Manitoba	OCL	Outdoor-Clear	D	Toxic	4	Flooded
LS	Flurries/Light Snow	ON	Ontario	-	Etc.	E	High Noise	5	Minor Snow
HS	Steady/Heavy Snow	QC	Quebec			F	Radioactive	6	Major Snow
-	Etc.	NS	Nova Scotia			G	High Humidity	7	Ice covered
		NT	Northwest Territories			H	Expose to explosion	-	Etc.
-	-	-	Etc.	-	Etc.	-	Etc.	-	Etc.

The data available in the chart shown in Table 12 may be applied differently based on the target rate model. The models below were chosen from the many available, and each one may be applicable depending on the criteria. It should be mentioned that, in such models, an overall activity rate evaluation is required for each project and trade individually, which has been named the Craft Average Target Rate. Because Activity Analysis is a rather new method being implemented on sites and there may be insufficient data available, the models below are presented in order of the amount of data required, beginning with models that require less data and ending with those that necessitate a more adequate database.

$$\vec{F}_1(x) = (\vec{A}) \times \prod_{i=1}^k f_i$$

$$\vec{F}_2(x) = (\mathbf{B}_{n \times m}) \times \begin{bmatrix} \prod_{i=1}^{k-1} f_{1,i} \\ \vdots \\ \prod_{i=1}^{k-1} f_{m,i} \end{bmatrix}_m$$

$$\vec{F}_3(x) = (\mathbf{C}_{n \times m \times p}) \times \begin{bmatrix} \prod_{i=1}^{k-2} f_{1,1,i} & \cdots & \prod_{i=1}^{k-2} f_{1,p,i} \\ \vdots & \ddots & \vdots \\ \prod_{i=1}^{k-2} f_{m,1,i} & \cdots & \prod_{i=1}^{k-2} f_{m,p,i} \end{bmatrix}_{m \times p}$$

Figure 63: Potential Functional Models for Activity Target Rates

In models above $\vec{F}_1(x)$, $\vec{F}_2(x)$, $\vec{F}_3(x)$ contain vectors defined as the Desired Target Rate, which have been evaluated for each activity category individually.

In the first model, \vec{A} is Craft Average Target Rate vector, and f_i is the adjusting coefficient for each factor affecting labourers' work on site, based on Table 12. The multiplication of all coefficients results in an adjustment factor for the desired target rate.

Adjustment *Factor*

$$= f_{activity} \times f_{temperature} \times f_{trade} \times f_{day} \times f_{shift} \times f_{precipitation} \times f_{location} \\ \times f_{(in,out)door} \times f_{work\ condition} \times f_{ground\ cond.}$$

The first model is adequate when an insufficient amount of data is available. It presents a target rate without consideration of the interrelations among the factors. In other words, the first model assumes that each factor influences the target rate independently of the other factors. This is in fact quite a typical estimating function in practice in construction.

The second and third models can be used when enough data are available. Although these models are more accurate and partially cover the interrelations between factors, a lot of data are required in order to obtain the model parameters. It should be noted that as these models become more comprehensive, the number of factors increases, which makes them difficult or sometimes impossible to identify. Last but not least, since all relations are linear, the model may not predict the nonlinear interrelations between two or more than two factors. These models follow a specific pattern that is the multiplication of two matrices. The second model can be used to clarify this explanation, as presented in the following paragraph.

$(B_{n \times m})$ is a matrix containing n rows and m columns. The number of rows indicates the number of trades available on a site, and the number columns represents one of the factors, for example, the weather conditions. A matrix must therefore be created that has data for all trades in different weather conditions. This matrix can be referred to as the Average Target Rate for Different Weather Conditions. The second part of this model is a vector having m elements. Each component represents the multiplication of all of the adjusting coefficients for each factor in a specific weather condition. It is worth mentioning that the reason for having $n-1$ factors is that one factor is already being taken into account, and at this point, the relation between temperature and the other factors is covered. As an example, the impact of cold weather and bad ground conditions on a desired target rate may be greater than that of moderate weather and bad ground conditions.

In the third model, $(C_{n \times m \times p})$ is a matrix containing n number of trades; m number of, for example, weather conditions; and p number of another criterion factor (for example, location). This matrix has $n \times m \times p$ number of components. For example, each component can represent a specific trade in a specific location with specific weather conditions. The second matrix in this model therefore represents the multiplication of other factors for one specific component in the first matrix. This model is more

comprehensive than the previous model because it indicates the interrelations of three factors with one another.

These models may become broader as the number of factors increases in the first matrix. However, the difficulty with such models is as follows:

1. An extensive amount of data is required in order to identify the model.
2. The procedure for identifying the unknown parameters of the model becomes increasingly complicated as the model grows.
3. As the model grows, it becomes increasingly difficult to establish the model.

To tackle these problems, a novel method that uses an adaptive network-based fuzzy inference system has been developed and is introduced below. This model can be easily expanded for any number of factors, and the inherited nonlinearity of its structure allows a more accurate approximation of the estimated target rates. As well, tools and techniques for training these networks have already been developed, and the model can be identified using a smaller number of data points than is required for the previous models.

4.3.2 Adaptive Neuro-Fuzzy Inference System

A total of three case studies were conducted. Each project included two 3- to 4-day visits, several weeks apart. All sites were visited by the author, and the data obtained from those visits were used in this particular model to estimate target rates for the following reasons:

1. Since these projects were visited by the author, data on weather and other factors were available, results may be more precise and uniform, and hence, the possibility of errors is reduced.
2. The data points mentioned were used only to justify the use of this model, to demonstrate the procedure, and to show how this model could be produced. The aim was not to validate this model.

Observations were recorded for a total of 17 days. The data for each day was normalized for each trade in order to obtain the percentage of direct work, preparation work, etc. Table 13 shows the normalized direct work rate that was measured for each trade over the 17 days. Where there were no measured data or where a trade was not present during one of the visits, the table has been left blank, and the data were omitted from the remainder of the calculations. Similar tables for all work activity categories were extracted from the data obtained from the visits.

Table 13: Normalized direct work rate for three projects measured over 17 days

Trade \ Day	1	2	3	4	5	6	7	8	9	10	11	12	13	14	15	16	17
Pipefitter	0.29	0.25	0.32	0.31	0.37	0.38	0.26	0.26	0.24	0.26	0.27	0.39	0.29	0.26	0.35	0.26	0.26
Civil	0.25	0.25	0.26	0.26	0.34	0.37	0.33	0.24	0.22	0.21	0.23	0.29	0.29	0.32	0.32	0.27	0.30
Electrical	0.10	0.19	0.23	0.30	0.26	0.35	0.27	0.35	0.27	0.36	0.18	⊗	⊗	⊗	0.15	0.10	0.11
Operator	0.45	0.38	0.45	0.37	0.58	0.55	0.53	0.50	0.46	0.44	0.40	0.61	0.63	0.60	0.53	0.45	0.43

The normalized rates for each work activity category were compiled into percentage charts for each trade not only to show the average activity rates for each trade and the variations in those activities, but also to enable a comparison of those work activity rates among different trades. Figure 64 shows the direct work rate for the different trades.

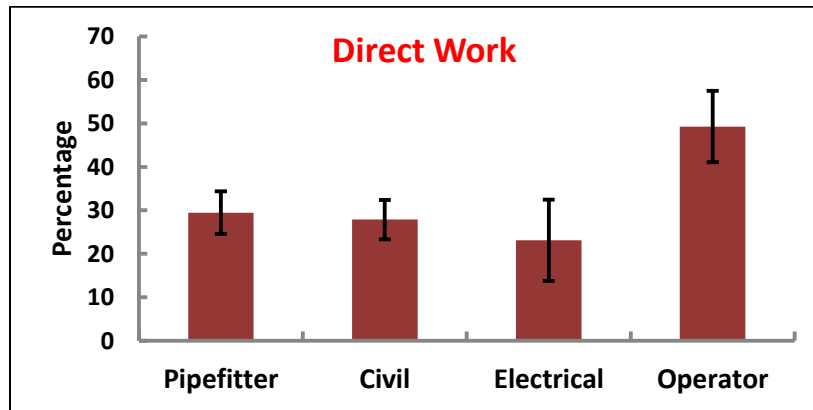

Figure 64: Average normalized direct work rate for different trades

The error bars in the figure represent the standard deviation for 17 days. It can be observed that the trades play an enormous role in the direct work rate. Because of their unique work environment, less travel time, and almost no material handling or tools/equipment activities, operators have higher direct work rates, while pipefitters, electricians, and civil workers show lower direct work rates due to their greater travel time, preparation work, and wait time. The wider error bars, which show larger deviations from the average, could be due to parameters such as the complexity of the work or the work stage, which makes them more sensitive; however, the author believes that a relatively lower number of labourers, for

example, electrical workers compared to pipefitters and civil workers, causes greater variations, even with small changes in the number of observations.

Another activity that can be studied as a means of comparing different trades is the preparation work. Figure 65 shows the preparation work rates and their variation throughout the 17 days of observation of the different trades.

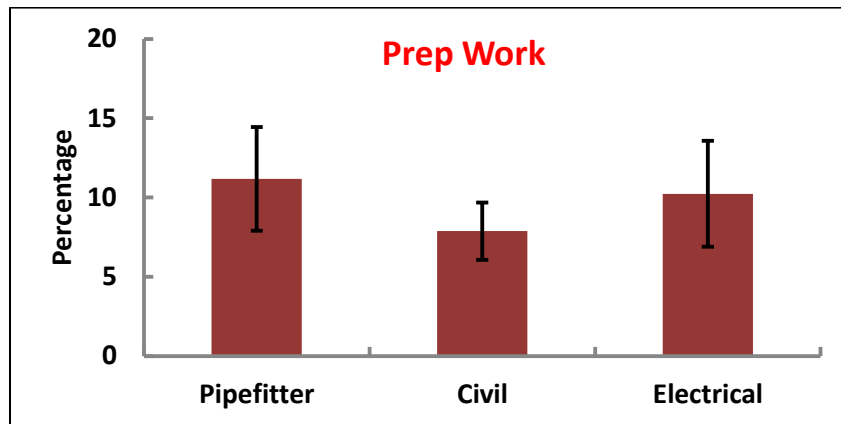

Figure 65 : Average normalized preparation work rate for different trades

In Figure 65, the operators have been omitted mostly because they do not usually have any preparation work, so the number of observations recorded for that trade was insignificant and entailed a large variation. The larger relative variations in preparation work for different trades are due primarily to the relatively smaller share of prep work in the daily activities. The variations in the observations are within the measurement error; however, due to the smaller number of prep work observations, the variations are larger.

Tools/equipment and material handling, although representing a smaller share of the overall activity rate, are among the activities that are highly variable from one day to another, and they are also trade dependent. Therefore, their greater deviations from the average can be explained based on the nature of those activities. Figure 66 shows the tools/equipment and material handling work rates and their variations among the different trades over the 17 days of observation.

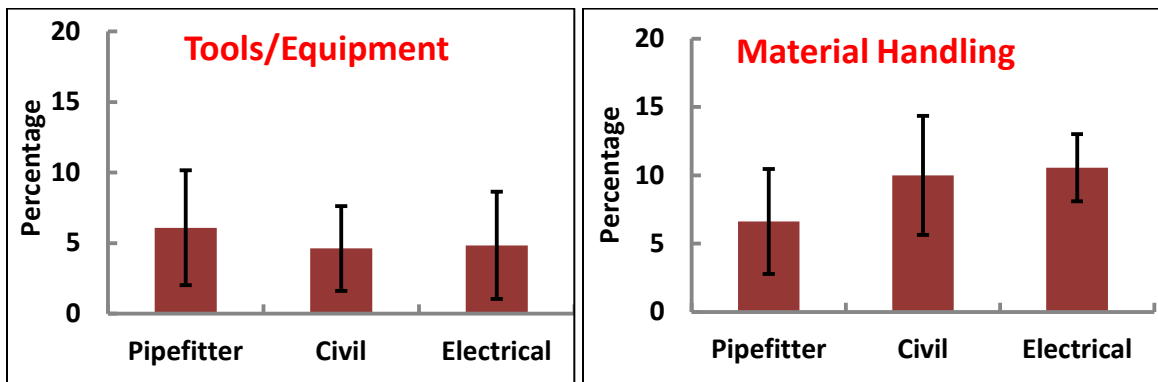

Figure 66: Average normalized tools/equipment and material handling rates for different trades

Waiting represents a small share of the overall activity rate and varies from one trade to another, with the day-to-day variations being due to the nature of this activity. However, travel corresponds to a larger share than that of other activities, and may vary from one trade to another. Figure 67 shows the average normalized waiting and travel times for different trades. The waiting time also depends on the daily schedule as well as on obstacles that may arise unexpectedly. Trades such as electrical that have a smaller number of workers and therefore a smaller number of observations may show larger variations from one day to another.

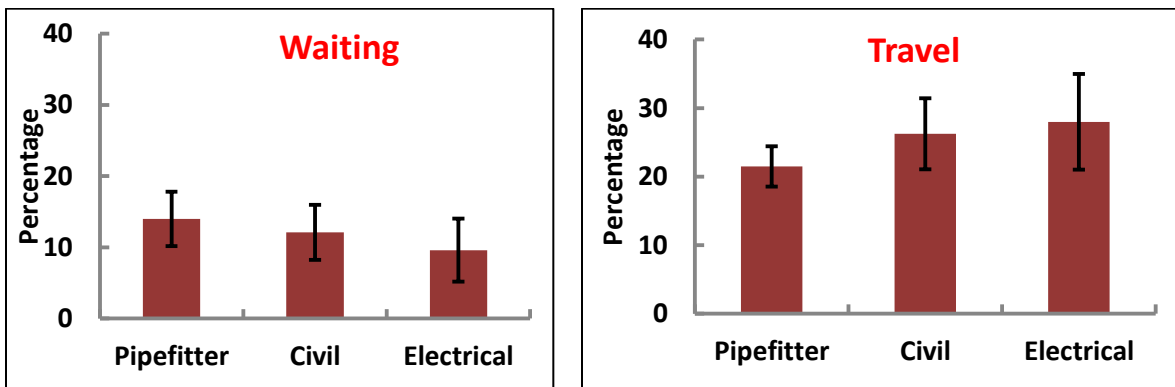

Figure 67: Average normalized waiting and travel time rates for different trades

Workers spend a portion of their time engaged in personal activities such as going to washrooms, benches to rest, etc. Figure 68 shows the average normalized personal time for each trade. Again, the higher variation in personal time for electrical workers is due to the smaller number of those workers and therefore the smaller number of observations, which makes these data more sensitive to observation errors.

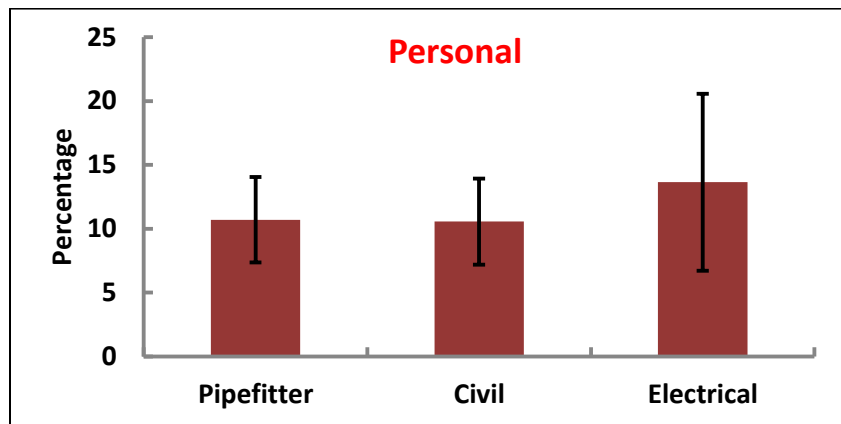

Figure 68: Average normalized personal work rate for different trades

Figure 69 shows the overall activity rates for all trades. An examination of this chart allows a comparison of the activity rates among trades.

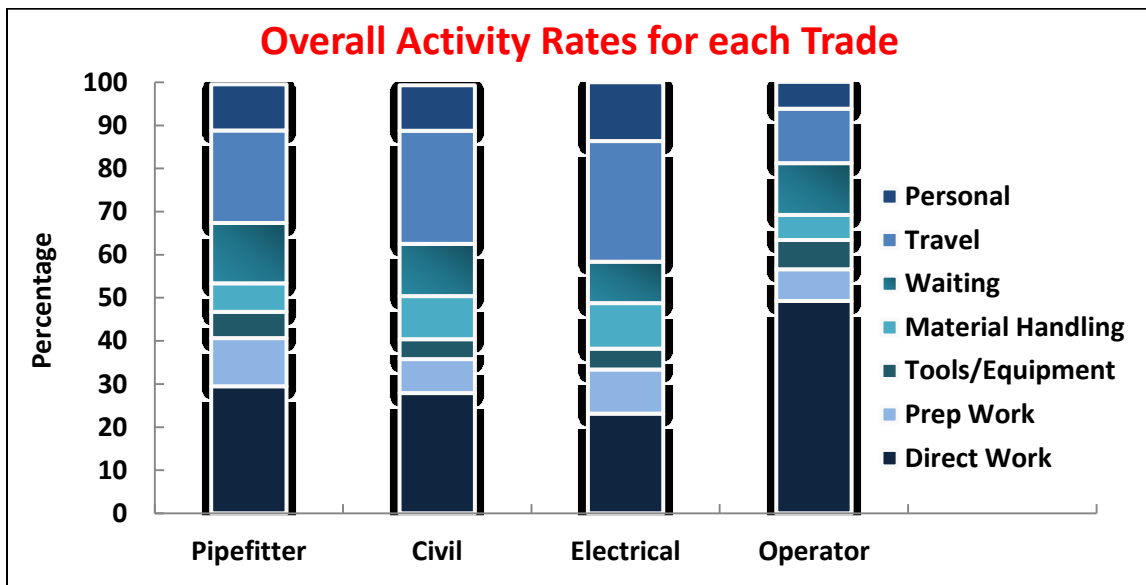

Figure 69: Overall activity rates among different trades

The data presented in this section was used to tune the mathematical model for predicting the target rates. Although the number of present data is not significant, it may indicate the possibilities of such a mathematical model, and it provides an incentive for expanding the number of measurements so that the activity rates can be better understood.

4.3.2.1 Mathematical Model

During the past few decades, modern processing techniques, e.g., fuzzy logic and neural networks, have provided attractive alternatives to the traditional equation-based techniques as a means of accommodating the nonlinearity and imprecise information involved in modeling complex and ill-defined systems. An adaptive network-based fuzzy inference system (ANFIS) is a specific approach in neuro-fuzzy modeling that utilizes neural networks to tune rule-based fuzzy systems (Jang, 1992).

The purpose of this section is to propose a new approach, based on an ANFIS, for the estimation of the direct work rate as well as that of other activity categories to enable the more accurate estimation of target rates as a means of improving on-site performance. It was hypothesized that such an ANFIS-based estimation tool can account for the imprecision, uncertainty, and nonlinearity characteristics of activity rate measurements and of target rate estimation and can therefore provide more accurate results, given that enough rich and extractable data exist to train the neural network in order to tune the fuzzy rule base (Jang, 1993).

4.3.2.2 ANFIS Architecture and Function

ANFIS is a fuzzy inference system represented by an adaptive neural network that models the mapping function between the input and output data through a hybrid learning algorithm (Jang, 1992; Jang, 1993). To provide an understanding of the ANFIS architecture and function, a simple system with two rules, two sets of input, two fuzzy sets for each set of input, and one set of output is given as an example. The first-order Takagi-Sugeno-Kang (TSK) fuzzy if-then rules are as follows:

Rule 1: *if x is A_1 and y is B_1 then $f_1 = p_1x + q_1y + r_1$*

Rule 2: *if x is A_2 and y is B_2 then $f_2 = p_2x + q_2y + r_2 \rightarrow f = \frac{\omega_1 f_1 + \omega_2 f_2}{\omega_1 + \omega_2} = \bar{\omega}_1 f_1 + \bar{\omega}_2 f_2$*

where x and y are system input; μ_{A_i} and $\mu_{B_{i-2}}$ are the fuzzy sets; p_i , q_i , and r_i are the consequent parameters that are determined during the training phase; f_i is the i th fuzzy rule output within the fuzzy region

specified by the fuzzy rule; and ω_i is the firing strength of the i th rule. As shown in Figure 70, the corresponding ANFIS architecture includes five functional layers, including the following:

Layer 1: Each node in this layer represents a fuzzy set converting the input into a fuzzy membership grade as output:

$$O_{1,i} = \mu_{A_i}(x), \quad i = 1,2$$

$$O_{1,i} = \mu_{B_{i-2}}(y), \quad i = 3,4$$

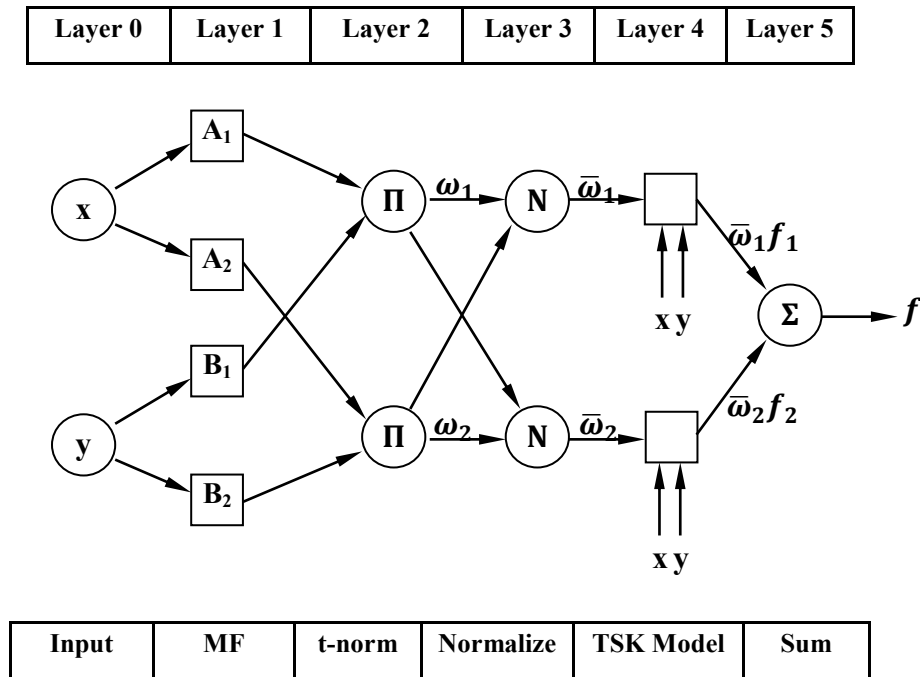

Figure 70: The architecture of an ANFIS with two inputs and two rules. Squares represent adaptive nodes with adjustable parameter sets, whereas circles represent fixed nodes with fixed parameter sets.

where x (or y) is the input, μ_{A_i} (or $\mu_{B_{i-2}}$) is the membership function of fuzzy set A_i (or B_{i-2}), and $O_{1,i}$ represents the output of the i th node in the first layer. For a bell-shaped membership function, the following applies:

$$\mu(x) = \frac{1}{1 + \left| \frac{(x - c_i)}{a_i} \right|^{2b_i}}$$

where $\{a_i, b_i, c_i\}$ is the premise parameter set of the membership function

Layer 2: Nodes in this layer calculate the degree of fulfillment of the premise part of the rules by input values, using node functions as follows:

$$O_{2,i} = t(\mu_{A_i}(x), \mu_{B_i}(y)) = \mu_{A_i}(x)\mu_{B_i}(y) = \omega_i$$

where t is a t-norm operator such as multiplication or minimum, and $O_{2,i}$ represents the output of the i th node in the second layer. The output signal ω_i indicates the firing strength of the i th rule.

Layer 3: Each node in this layer normalizes the firing strength of a rule using a node function as follows:

$$O_{3,i} = \bar{\omega}_i = \frac{\omega_i}{\omega_1 + \omega_2}$$

Layer 4: Each node in this layer calculates the normalized output of a rule for current input x and y , using the following node function:

$$O_{4,i} = \bar{\omega}_i f_i = \bar{\omega}_i(p_i x + q_i y + r_i)$$

where $\{p_i, q_i, r_i\}$ is the consequent parameter set of rule i .

Layer 5: This layer consists of a fixed node that sums the output of the previous layer nodes to compute the overall network output:

$$O_{5,i} = \sum_i \bar{\omega}_i f_i = \frac{\sum_i \omega_i f_i}{\sum_i \omega_i}$$

The adaptive nodes in layers 1 and 4 have a set of adjustable premise and consequent parameters: $\{a_i, b_i, c_i\}$ and $\{p_i, q_i, r_i\}$. During the learning procedure, these parameters are tuned to make the ANFIS output match the training data, using a learning algorithm. The output is generally written as a nonlinear function of the premise parameters and as a linear function of the consequent parameters:

$$f = \frac{\omega_1 f_1 + \omega_2 f_2}{\omega_1 + \omega_2} = \bar{\omega}_1(p_1 x + q_1 y + r_1) + \bar{\omega}_2(p_2 x + q_2 y + r_2)$$

It has been shown that a hybrid algorithm, consisting of a forward pass and a backward pass, is quite efficient in finding the optimal values of these parameters (Jang, 1992). In the forward pass, the premise parameters are assumed to be fixed, and the optimal values of the consequent parameters are estimated using the least squares method. Using these parameters, the output of the system is then calculated, and the resulting error is used to adjust the premise parameters through a standard back propagation algorithm. In this backward pass, the consequent parameters are assumed to be fixed, and a gradient descent algorithm is used to find the optimal values of the premise parameters.

Another important issue in developing an ANFIS that needs to be addressed is the optimal numbers of rules and fuzzy sets (membership functions). An appropriate method for making such decisions is to cluster the input data so that the natural groupings of data are identified in order to produce a concise representation of the system's behaviour. In an ANFIS, the clustering results are used to generate a TSK fuzzy inference system that best models the data using a minimum number of rules. These rules, in turn, partition the input space according to the fuzzy qualities associated with each of the data clusters. The most popular clustering algorithm is the subtractive clustering method, which is particularly effective in the absence of a clear idea of the appropriate number of clusters for a given data set. The subtractive clustering method has been shown to be a fast one-pass algorithm capable of determining both the number of clusters and the cluster centers for such cases (Chiu, 1994).

4.3.2.3 ANFIS Implementation and Evaluation

As explained in the previous section, the ANFIS can be trained to model a complex and nonlinear system, especially one with qualitative input such as weather conditions. A better definition of an ANFIS model requires consideration of all affecting parameters and, based on the complexity of the desired model, the choice of a select number of those parameters that have the most impact on the results.

A number of factors may affect the activity rate and should be considered in predicting the target rates. Those factors cannot usually be controlled by the managerial level, the foremen, or the workers on site. For example, the weather can have a significant impact on the direct work rates. For any particular month of the year, setting the same targets for an ironworker in Ontario and for one in Texas is unrealistic. The Ontario ironworker must contend with cold and snow during the winter. In the summer, the Texas worker deals with extreme heat, which slows his production.

The following is a list of factors that should be considered when activity targets are set (Gouett et al., 2012). It should be noted that this list is not exhaustive and that a construction manager may include other factors that are beyond his control. Factors which could be influenced by the managers should not be considered among the factors that affect the target rates.

1. Type of project
2. Scope and size of the project
3. Complexity of the project
4. Stage of the project
5. Type of craft
6. Geographical location of the project
7. Weather conditions
8. Special site conditions beyond management control

For the modeling developed for this research, two of the factors listed above were considered: type of craft and weather conditions. For each of the activity categories, an ANFIS classifier with five layers was designed so that an output between 0 and 1 was produced, representing expected direct work rate. Although a model can be generated for each activity rate, the desired target rate would be primarily the expected direct work rate for purposes of demonstration. The database, including 65 data points for the direct work rate, was used to train the ANFIS model. Figure 71 shows all of the data points used for training the ANFIS. It is to note that the software used for this modeling is MATLAB.

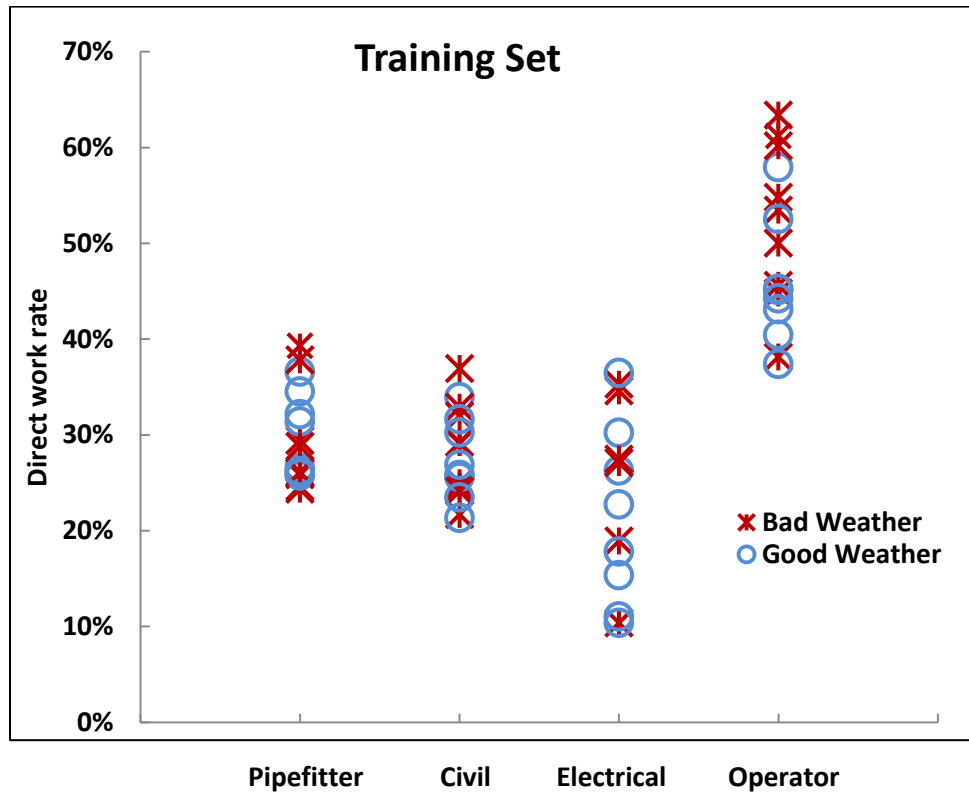

Figure 71: Data set used for training the ANFIS

The structure of the ANFIS was determined using the results of the data clustering as a guideline. The training data set was grouped using the subtractive clustering method with the influence range, squash factor, and accept and reject ratios set at, 0.4, 1.15, 0.5, and 1.15, respectively. One fuzzy rule was considered for each cluster, and each type of trade and weather condition as input variables were divided into as many fuzzy subsets as clusters using bell-shaped membership functions.

A rule of thumb mentioned by experts in the neural-network field indicates that the number of input-output sets used to teach the network should be at least 10 times the number of parameters of the network. Because of the standard structure of an ANFIS network, the number of architecture parameters with respect to the number of rules can be obtained by clustering the data set as follows:

$$\# \text{ of parameters} = \# \text{ of rules} \times [(\# \text{ of membership function parameters} + 1) \times \# \text{ of inputs} + 1]$$

It can be seen that the seven clusters that represent the seven rules of the TSK fuzzy inference system with two sets of input of the architecture will have 49 parameters, which requires approximately 500 rich data points. As shown in Figure 71, although the number of data points is very limited (i.e., 65 data points

for all of the trades), there are also many overlaps on the diagrams as well as many areas eligible for the direct work rate that are not covered by the present data set. The overlapping of the data points increases the number of learning points without increasing the density of the information that should be extracted by the neural network. More data points should therefore be used to train the architecture.

Figure 72 shows the architecture of the generated ANFIS. Seven clusters were obtained through the subtractive clustering method, and they represent the rules in the ANFIS.

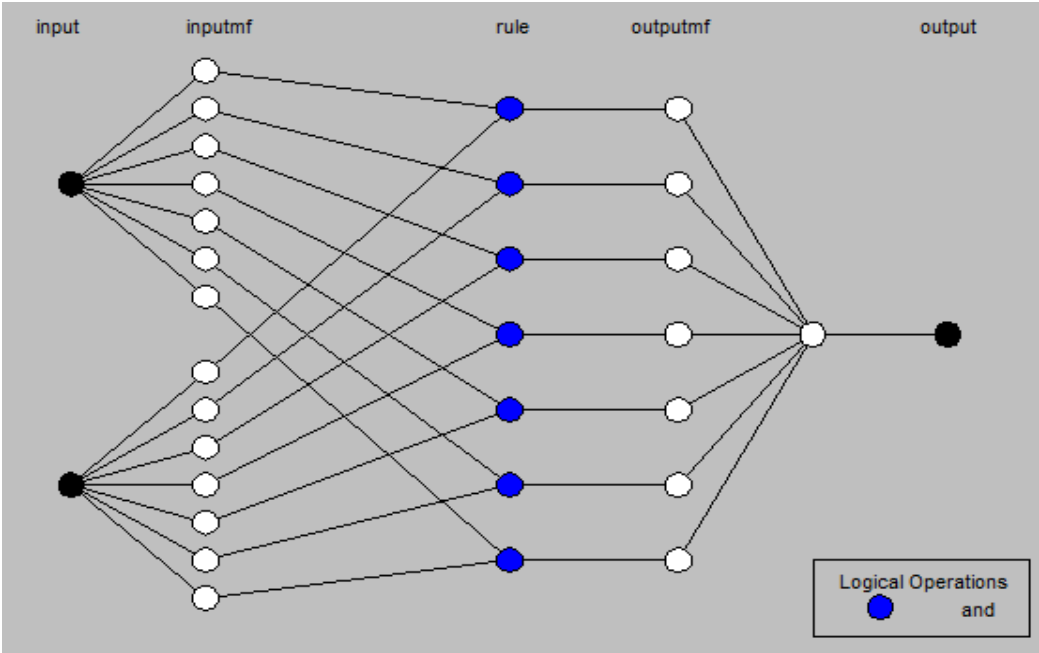
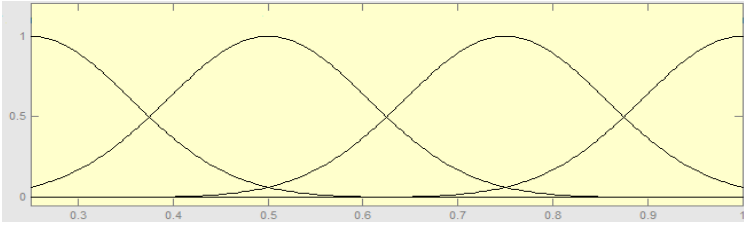
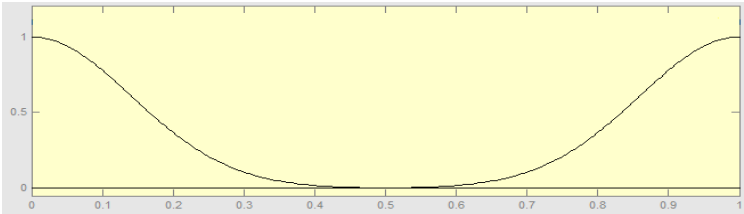

Figure 72: Architecture of the generated ANFIS

The membership functions of the TSK fuzzy inference system were initially set to have a uniform distribution of their range, as shown in Figure 73. After training, the membership functions were redistributed as shown in Figure 74.



(a)



(b)

Figure 73: Membership functions before training the ANFIS a) Type of trade MFs, b) Weather condition MFs

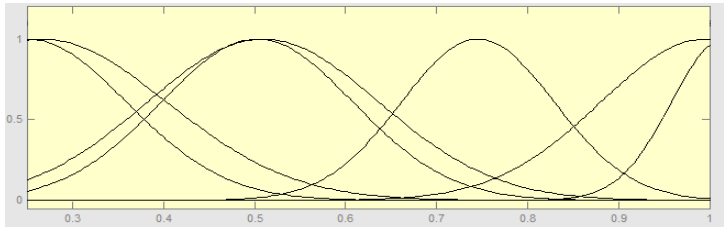

(a)

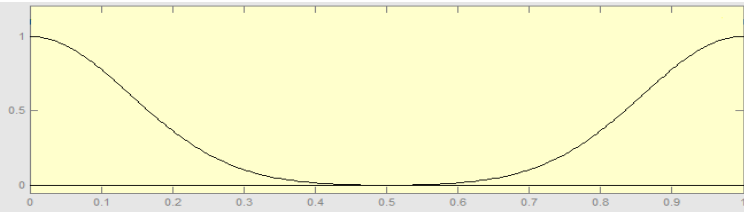

(b)

Figure 74: Membership functions after training the ANFIS a) Type of trade MFs, b) Weather condition MFs

4.3.2.4 Results and Discussion

The data set used to train the structure would ideally be verified, and the model should be validated in order to prove that the training covers all possible cases. One of the best-known validation techniques is cross validation. In a fourfold cross validation, given enough data points, the data set can be divided into four subsets and the network trained using three of the subsets, with the remaining one being used to test the network. This process can be repeated three additional times, and the results can be compared to ensure the validity of the trained model. However, a very limited number of data points available for training the network mean that the verification must be postponed until sufficient data have been gathered.

Considering that only two of the affecting parameters were considered for the current model and that only eight possibilities for input exist, all of the output of the model can be covered for four trades and for both good and bad weather conditions. The results are shown in Figure 75.

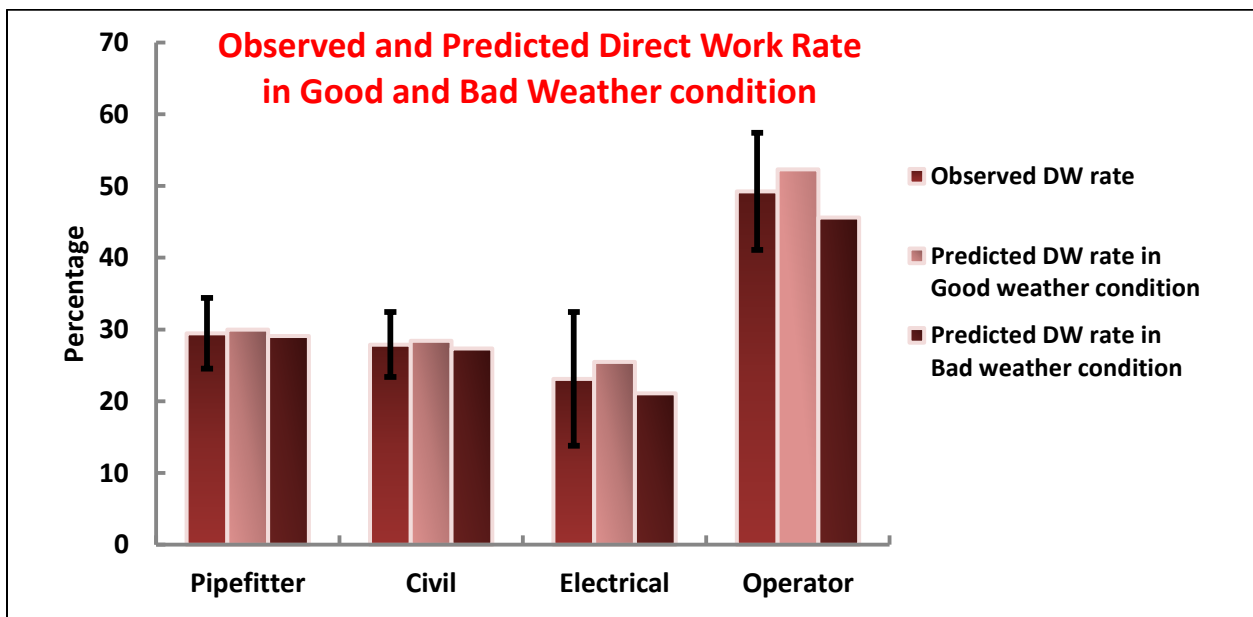

Figure 75: Observed and Predicted Direct Work Rate in Good and Bad weather condition

The results shown in Figure 75 prove that the model, although trained using few data points, predicts values for each trade and weather conditions that are consistent with the observed direct work rate.

The current model is merely proof of a concept that may be effective if enough data are available for a number of projects and their conditions, especially for parameters that may affect the direct work rate or

any other activity category. The input/output sets that were used to train the ANFIS were the observed activity rates. The ANFIS output after training would therefore be the activity rate based on the new conditions. It might be necessary to tune those results if the target rates are desired as the output of the ANFIS. For example, if the desired target rates are higher than the observed direct work rates, then the observed rates must be updated before the ANFIS is trained in order to ensure that the trained network will produce the desired target rates. The observed data for the target rates could be updated by the managerial level. There are several large corporations and consultants who are likely to have enough data to make use of the ANFIS approach. Unfortunately, it is not appropriate for the sponsor of this research at this time, so simpler methods of setting target rates must be explored.

4.3.3 Experience Based Approaches to set Target Rate

Based on previous work on Activity Analysis and work sampling, a number of methods have been recognized for evaluating an acceptable target rate, or better said, determining a value to compare with the actual rate in order to understand the trend, as well as to meet the requirements. The following are three of these methods:

1. An average value can be determined for every category performed by each trade individually.
2. A desired quartile can be relatively estimated for the values for each category and trade.
3. The best rates achieved over time for a specific craft and type of project can be used. These rates may be determined through the optimization of the values obtained in every category performed by each trade, by means of consideration of the maximum value among all for the direct work rate; the evaluation of the mean for preparation work, tools/equipment, and material handling; and finally, consideration of the minimum value for the last three categories. It should be noted that these values are chosen from a series of values available for a specific category and trade.

Since the data in hand were insufficient for the statistical validation of such an evaluation for each project individually, all data from section 4.2 were combined and a value for each activity category and trade was determined without consideration of the individual project characteristics.

Figures 76 to 82 show values for all activity categories performed by every trade and for each project independently.

Pipefitter											
Project Category	D	F	ID1	ID2	FR	OG	LB1	LB2	DN1	DN2	HN
Direct Work	28.00%	24.00%	11.57%	5.52%	33.90%	27.00%	31.00%	32.00%	26.00%	29.00%	30.16%
Prep Work	16.00%	14.00%	27.47%	22.73%	13.38%	15.85%	8.00%	10.00%	12.00%	13.00%	13.23%
Tools/Equip	12.00%	13.00%	8.06%	12.66%	10.00%	11.94%	4.00%	9.00%	3.00%	5.00%	10.58%
Mat'l Handling	4.00%	6.00%	1.46%	2.11%	7.00%	8.22%	9.00%	7.00%	9.00%	9.00%	1.06%
Waiting	16.00%	12.00%	16.17%	7.63%	12.08%	12.52%	18.00%	11.00%	15.00%	11.00%	14.29%
Travel	13.00%	27.00%	24.12%	37.34%	16.32%	16.92%	23.00%	21.00%	22.00%	21.00%	20.11%
Personal	11.00%	4.00%	11.14%	12.01%	7.30%	7.57%	7.00%	10.00%	13.00%	12.00%	10.58%
Total	100.00%	100.00%	100.00%	100.00%	100.00%	100.00%	100.00%	100.00%	100.00%	100.00%	100.00%

Figure 76: Pipefitter activity rates: all projects

Electrical									
Project Category	F	ID1	ID2	FR	OG	LB1	LB2	DN1	DN2
Direct Work	32.00%	9.00%	9.16%	36.40%	28.00%	20.00%	30.00%	31.00%	34.00%
Prep Work	8.00%	19.14%	19.68%	17.43%	15.40%	8.00%	13.00%	8.00%	17.00%
Tools/Equip	10.00%	10.46%	9.43%	13.13%	11.61%	4.00%	9.00%	4.00%	2.00%
Mat'l Handling	10.00%	3.56%	3.23%	9.04%	7.99%	9.00%	13.00%	11.00%	7.00%
Waiting	16.00%	19.14%	14.02%	8.09%	12.52%	15.00%	3.00%	10.00%	7.00%
Travel	19.00%	25.13%	30.46%	10.93%	16.92%	32.00%	22.00%	25.00%	22.00%
Personal	5.00%	13.39%	14.02%	4.89%	7.57%	12.00%	10.00%	11.00%	11.00%
Total	100.00%	100.00%	100.00%	100.00%	100.00%	100.00%	100.00%	100.00%	100.00%

Figure 77: Electrical activity rates: all projects

Operator									
Project Category	ID1	ID2	FR	OG	LB1	LB2	DN1	DN2	HN
Direct Work	41.03%	47.73%	66.60%	38.00%	43.00%	55.00%	45.00%	47.00%	63.70%
Prep Work	0.91%	0.00%	3.83%	9.68%	5.00%	8.00%	4.00%	5.00%	8.56%
Tools/Equip	0.61%	0.00%	2.88%	7.29%	4.00%	1.00%	2.00%	1.00%	1.03%
Mat'l Handling	0.00%	0.00%	1.99%	5.02%	4.00%	1.00%	3.00%	3.00%	0.00%
Waiting	38.30%	43.18%	8.36%	13.53%	15.00%	12.00%	15.00%	15.00%	16.44%
Travel	14.89%	4.55%	11.29%	18.29%	20.00%	15.00%	25.00%	22.00%	7.19%
Personal	4.26%	4.55%	5.05%	8.18%	9.00%	8.00%	6.00%	7.00%	3.08%
Total	100.00%	100.00%	100.00%	100.00%	100.00%	100.00%	100.00%	100.00%	100.00%

Figure 78: Operator activity rates: all projects

Civil									
Project Category	ID1	ID2	FR	OG	LB1	LB2	DN1	DN2	HN
Direct Work	34.68%	36.08%	49.10%	44.00%	25.00%	34.00%	24.00%	29.00%	45.55%
Prep Work	3.75%	11.86%	10.70%	11.44%	7.00%	8.00%	7.00%	7.00%	4.12%
Tools/Equip	11.86%	5.15%	8.06%	8.62%	6.00%	6.00%	2.00%	2.00%	1.52%
Mat'l Handling	5.26%	2.06%	5.55%	5.94%	13.00%	9.00%	12.00%	9.00%	3.20%
Waiting	10.06%	16.49%	8.96%	10.15%	15.00%	14.00%	23.00%	10.00%	14.60%
Travel	24.92%	20.10%	12.12%	13.72%	26.00%	21.00%	20.00%	30.00%	24.91%
Personal	9.46%	8.25%	5.42%	6.13%	8.00%	8.00%	12.00%	13.00%	6.10%
Total	100.00%	100.00%	100.00%	100.00%	100.00%	100.00%	100.00%	100.00%	100.00%

Figure 79: Civil activity rates: all projects

Ironworker					
Project Category	ID1	ID2	FR	OG	DN1
Direct Work	22.04%	15.23%	61.20%	31.00%	25.00%
Prep Work	18.23%	8.12%	3.43%	15.85%	9.00%
Tools/Equip	9.85%	14.21%	2.59%	11.94%	11.00%
Mat'l Handling	3.08%	0.00%	1.78%	8.22%	8.00%
Waiting	22.91%	12.18%	10.45%	11.16%	10.00%
Travel	17.49%	26.90%	14.13%	15.09%	26.00%
Personal	6.40%	23.35%	6.32%	6.75%	11.00%
Total	100.00%	100.00%	100.00%	100.00%	100.00%

Figure 80: Ironworker activity rates: all projects

Boilermaker			
Project Category \	FR	OG	DN1
Direct Work	54.70%	38.00%	29.00%
Prep Work	11.36%	14.52%	11.00%
Tools/Equip	8.55%	10.94%	10.00%
Mat'l Handling	5.89%	7.53%	8.00%
Waiting	6.60%	9.81%	15.00%
Travel	8.92%	13.26%	19.00%
Personal	3.99%	5.93%	8.00%
Total	100.00%	100.00%	100.00%

Millwright			
Project Category \	ID1	FR	OG
Direct Work	16.51%	43.80%	34.00%
Prep Work	15.90%	12.41%	15.85%
Tools/Equip	9.79%	9.35%	11.94%
Mat'l Handling	3.67%	6.44%	8.22%
Waiting	18.65%	9.47%	10.15%
Travel	22.94%	12.80%	13.72%
Personal	12.54%	5.72%	6.13%
Total	100.00%	100.00%	100.00%

Figure 81: Boilermaker and millwright activity rates: all projects

Carpenter				
Project Category \	ID1	ID2	FR	OG
Direct Work	25.70%	24.26%	45.70%	29.00%
Prep Work	14.25%	22.37%	15.23%	16.73%
Tools/Equip	8.08%	10.51%	11.47%	12.60%
Mat'l Handling	3.37%	3.77%	7.90%	8.67%
Waiting	22.45%	17.25%	6.66%	11.16%
Travel	20.09%	14.02%	9.01%	15.09%
Personal	6.06%	7.82%	4.03%	6.75%
Total	100.00%	100.00%	100.00%	100.00%

Cement finisher				
Project Category \	ID1	ID2	FR	OG
Direct Work	57.95%	66.67%	47.60%	37.00%
Prep Work	11.36%	0.00%	11.09%	18.05%
Tools/Equip	7.95%	0.00%	8.36%	13.59%
Mat'l Handling	1.40%	0.00%	5.75%	9.36%
Waiting	14.77%	25.00%	9.20%	7.44%
Travel	2.27%	8.33%	12.44%	10.06%
Personal	4.55%	0.00%	5.56%	4.50%
Total	100.00%	100.00%	100.00%	100.00%

Figure 82: Carpenter and Cement finisher activity rates: all projects

Three methods have been introduced for estimating the target rate. The first method, referred to as “Average” is basically the average for one activity category and trade for all projects. If a sufficient amount of data were available, it would be desirable to include project characteristics as well. The second method, designated “Desired Quartile”, determines the third quartile values for direct work and trade accordingly then a second quartile is applied to the non-productive activities and the target support activities defaults to “Average”. The third method, called “Optimal Value”, is an approach to choosing the best rate available for every category individually; the procedure for choosing the desired rates is as explained previously. The target rates were estimated using all three methods for every category and trade; Figure 82 summarizes the results.

Method	Trade Category	Pipefitter	Civil	Operator	Electrical	Ironworker	Boilermaker	Millwright	Carpenter	Cement finisher
Average	Direct Work	25.29%	35.71%	49.67%	25.51%	30.89%	40.57%	31.44%	31.17%	52.31%
	Prep Work	15.06%	7.87%	5.00%	13.96%	10.93%	12.29%	14.72%	17.14%	10.12%
	Tools/Equip	9.02%	5.69%	2.20%	8.18%	9.92%	9.83%	10.36%	10.67%	7.48%
	Mat'l Handling	5.80%	7.22%	2.00%	8.20%	4.22%	7.14%	6.11%	5.93%	4.13%
	Waiting	13.24%	13.58%	19.65%	11.64%	13.34%	10.47%	12.76%	14.38%	14.10%
	Travel	21.98%	21.42%	15.36%	22.60%	19.92%	13.73%	16.49%	14.55%	8.27%
	Personal	9.60%	8.48%	6.12%	9.87%	10.76%	5.97%	8.13%	6.16%	3.65%
Desired Quartile	Direct Work	31.00%	44.78%	59.35%	33.00%	46.10%	54.70%	43.80%	41.53%	64.49%
	Prep Work	15.06%	7.87%	5.00%	13.96%	10.93%	12.29%	14.72%	17.14%	10.12%
	Tools/Equip	9.02%	5.69%	2.20%	8.18%	9.92%	9.83%	10.36%	10.67%	7.48%
	Mat'l Handling	5.80%	7.22%	2.00%	8.20%	4.22%	7.14%	6.11%	5.93%	4.13%
	Waiting	12.52%	14.00%	15.00%	12.52%	11.16%	9.81%	10.15%	14.21%	11.99%
	Travel	21.00%	21.00%	15.00%	22.00%	17.49%	13.26%	13.72%	14.55%	9.19%
	Personal	10.58%	8.00%	6.00%	11.00%	6.75%	5.93%	6.13%	6.40%	4.52%
Optimized Rates	Direct Work	33.90%	49.10%	66.60%	36.40%	61.20%	54.70%	43.80%	45.70%	66.67%
	Prep Work	13.38%	7.00%	5.00%	15.40%	9.00%	11.36%	15.85%	15.98%	11.23%
	Tools/Equip	10.00%	6.00%	1.03%	9.43%	11.00%	10.00%	9.79%	10.99%	8.15%
	Mat'l Handling	7.00%	5.94%	1.99%	9.00%	3.08%	7.53%	6.44%	5.83%	3.58%
	Waiting	7.63%	8.96%	8.36%	3.00%	10.00%	6.60%	9.47%	6.66%	7.44%
	Travel	13.00%	12.12%	4.55%	10.93%	14.13%	8.92%	12.80%	9.01%	2.27%
	Personal	4.00%	5.42%	3.08%	4.89%	6.32%	3.99%	5.72%	4.03%	3.00%

Figure 83: Target rates according to all three estimation methods

Based on industry requirements and the interpretations of the managerial level, one of the methods above was selected for setting target rates. The following explains the usefulness of each method:

1. An average value resulting from the first method is only an understanding of the values obtained, in other words, a spectrum of bad and good values.
2. The second method is useful because of the definition of the desired quartile value obtained from previous cycles as a target rate to achieve during the subsequent cycle. It represents a possible and realistic goal.
3. Because the goal in the last method is to estimate ideal values for each category and trade from all previous cycles, this approach may be acceptable for determining the desired target rate and the ultimate goal to be achieved during the subsequent cycle.

Figure 84 is a chart that compares these different target rate approaches and the values obtained with each method.

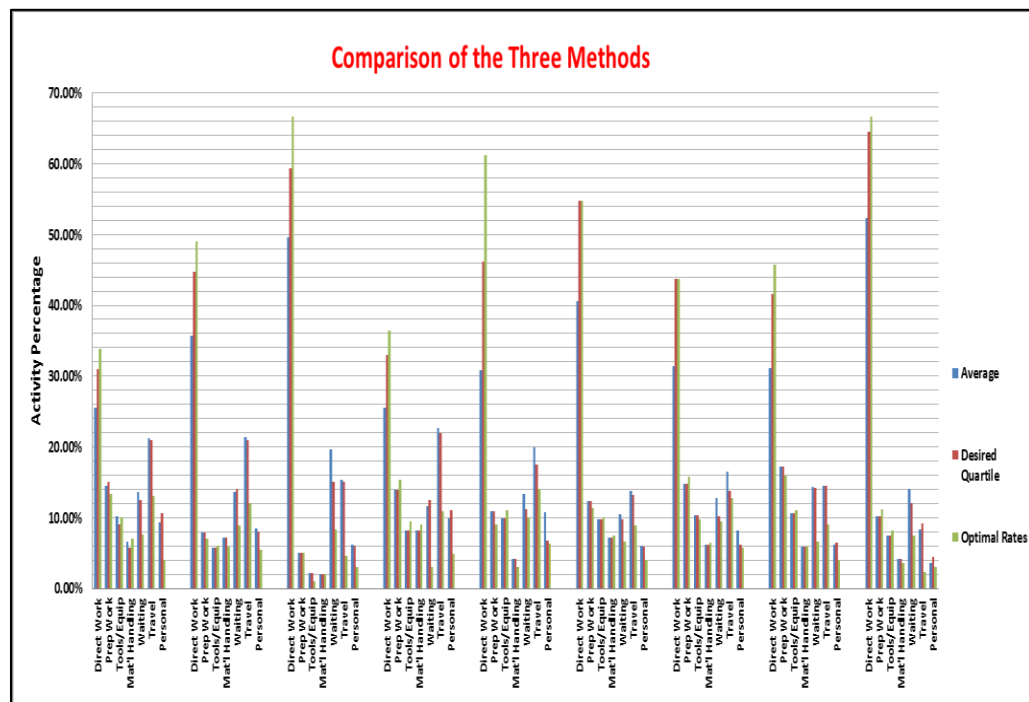

Figure 84: Comparison of the three target rate approaches

To provide the results in more detail, target rates were set for each trade individually. Figures 85 to 93 show the charts that include values produced by the different target rate methods for each trade.

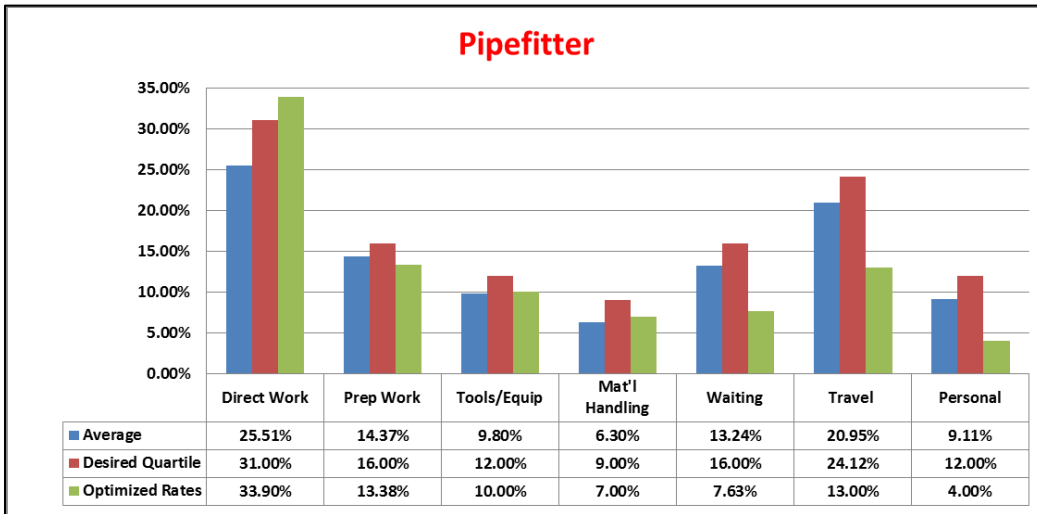

Figure 85: Target rates for pipefitters estimated by all three methods

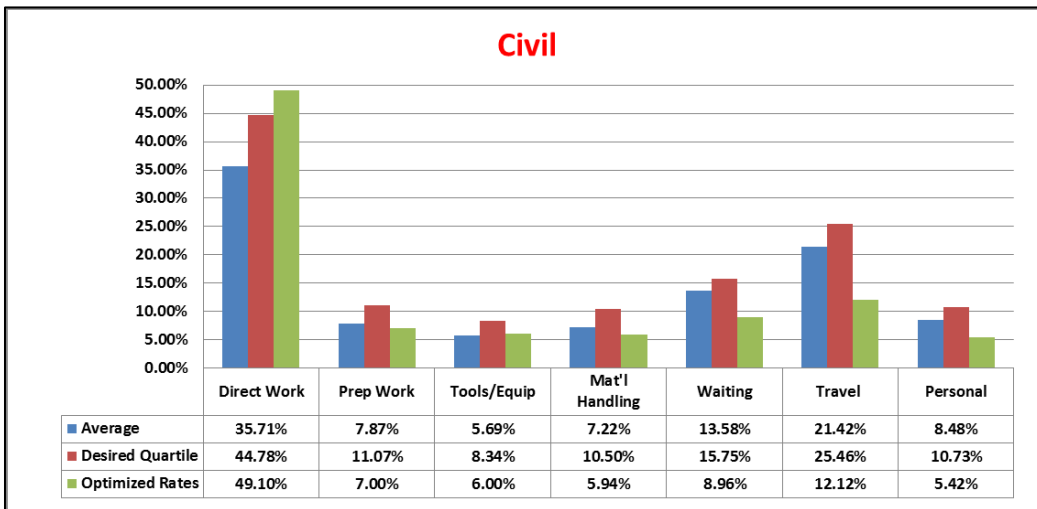

Figure 86: Target rates for civil workers estimated by all three methods

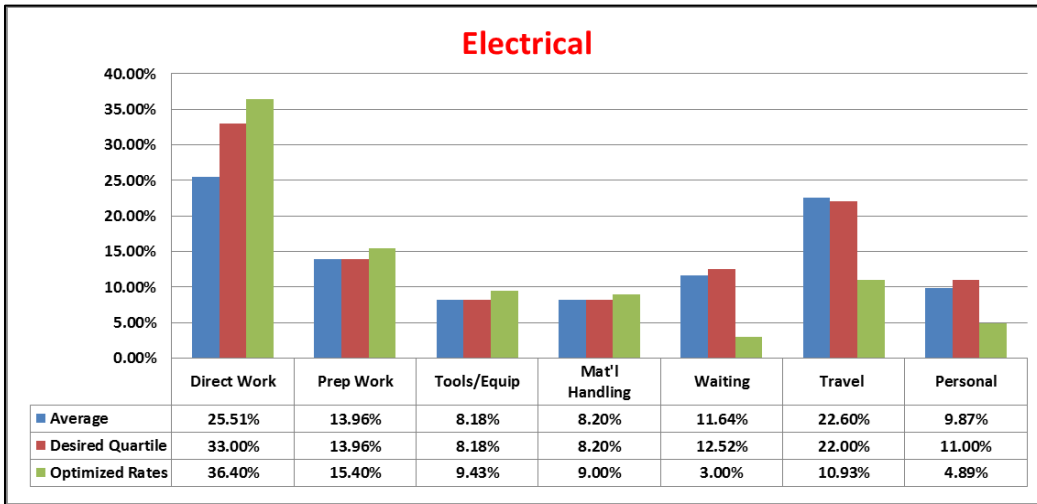

Figure 87: Target rates for electricians estimated by all three methods

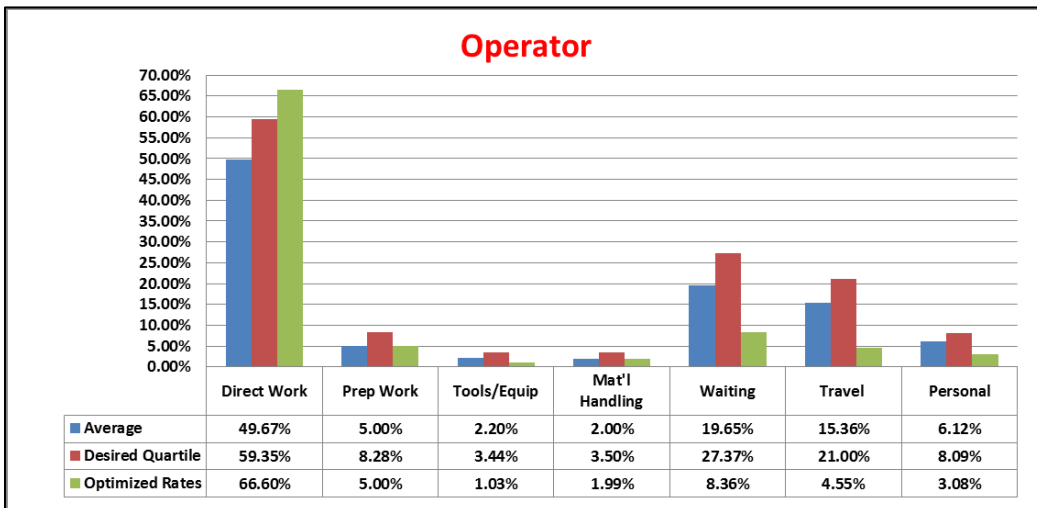

Figure 88: Target rates for operators estimated by all three methods

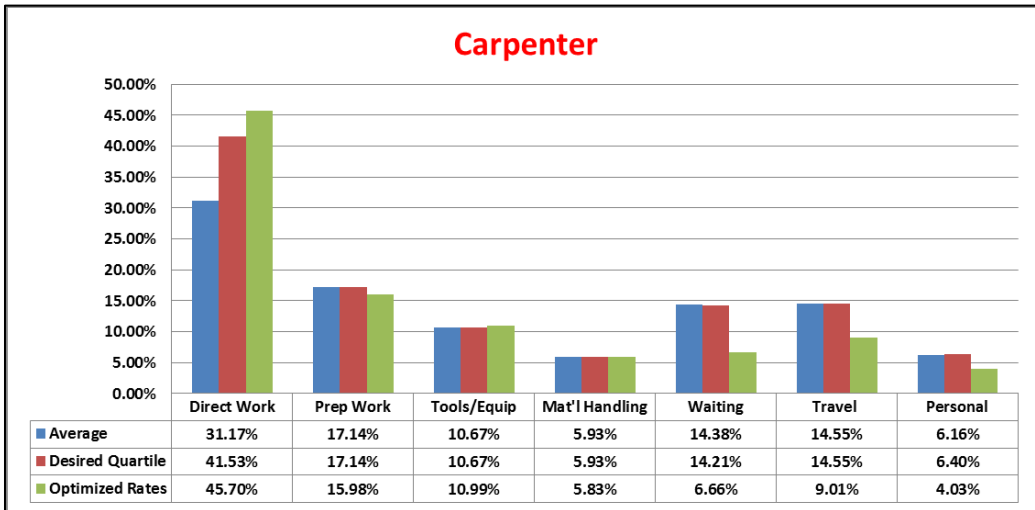

Figure 89: Target rates for carpenters estimated by all three methods

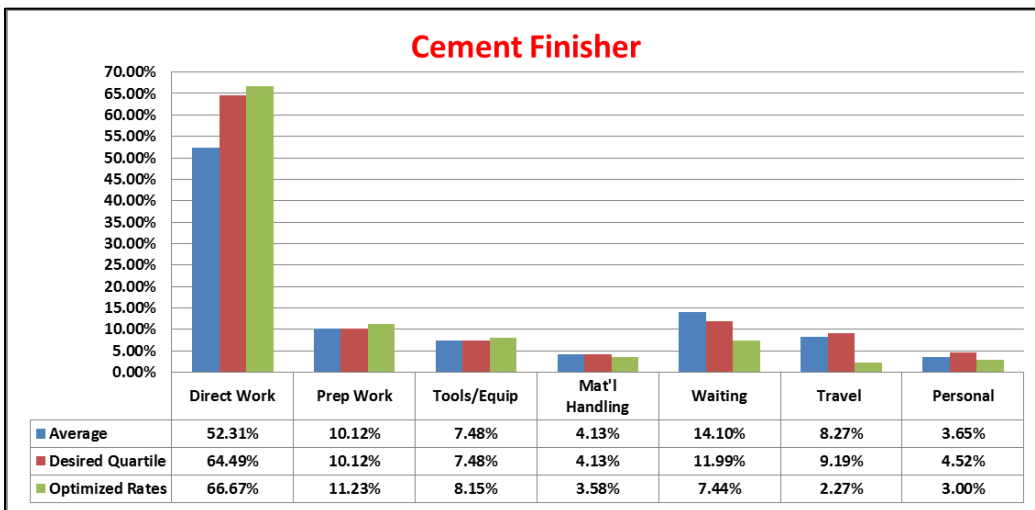

Figure 90: Target rates for cement finishers estimated by all three methods

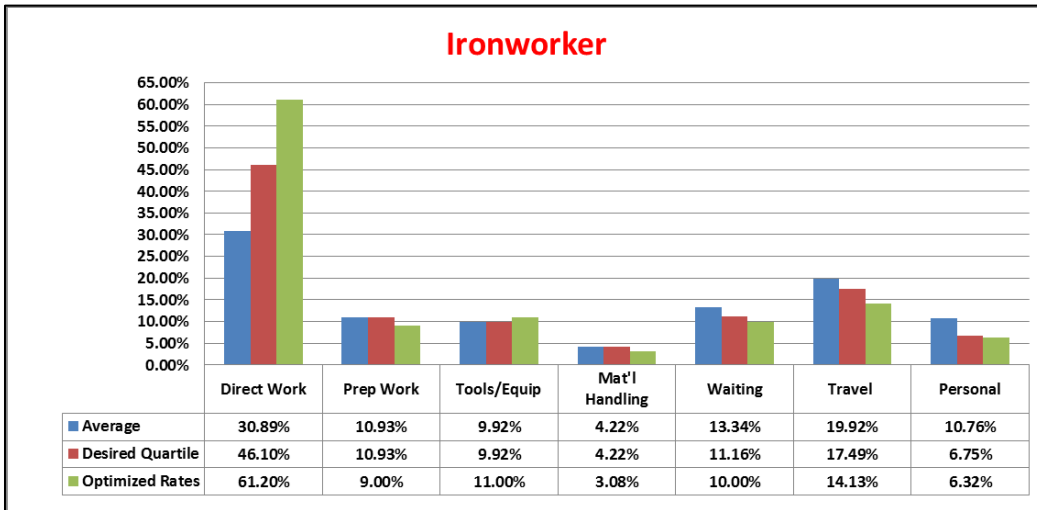

Figure 91: Target rates for ironworkers estimated by all three methods

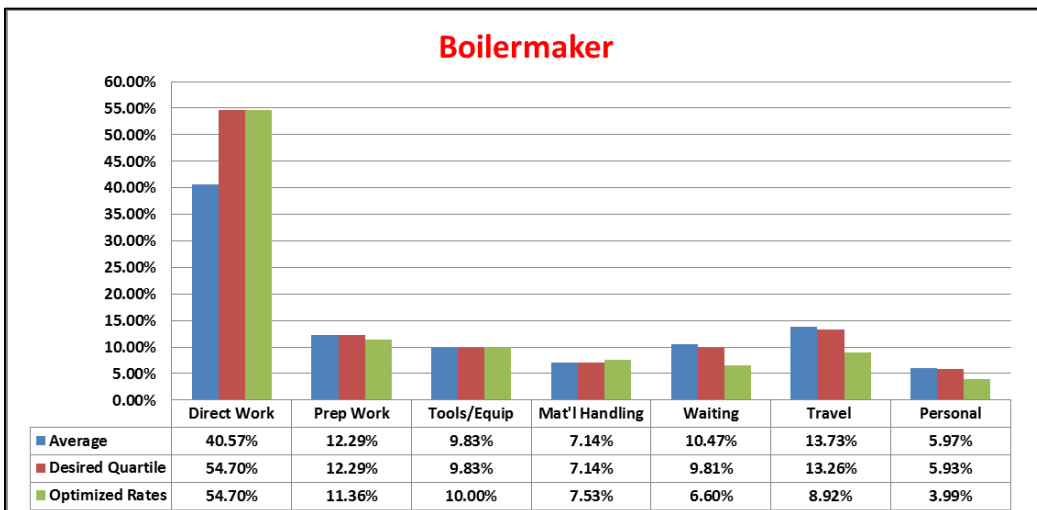

Figure 92: Target rates for boilermakers estimated by all three methods

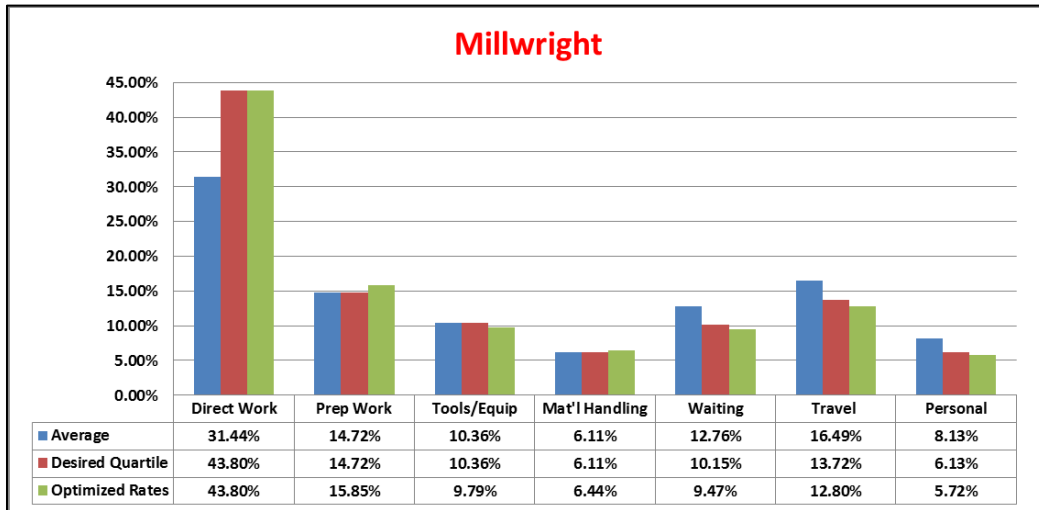

Figure 93: Target rates for millwrights estimated by all three methods

To briefly compare the target rates for the trades with one another and demonstrate that target rates must be set for each trade and category individually, an average of the target rates produced by all of the methods has been calculated for each trade. These values are provided in the chart shown in Figure 94.

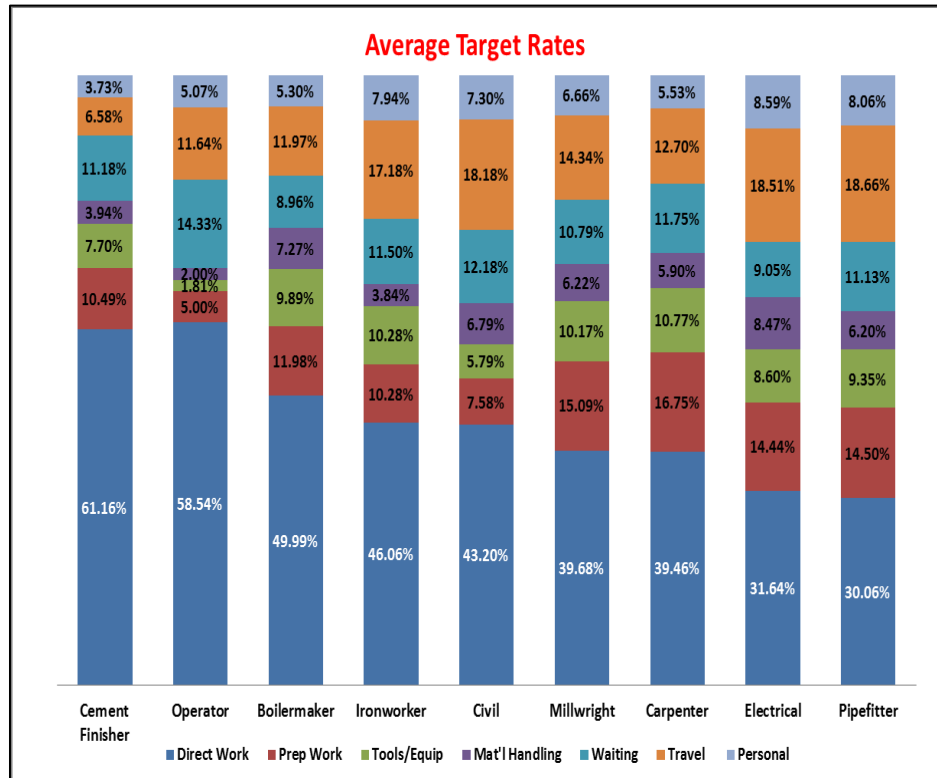

Figure 94: Trade-specific average target rates

As can be seen in Figure 94, the typical target rate for direct activities is 61.16 % for cement finishers, 58.54 % for operators, 49.99 % for boilermakers, 46.06 % for ironworkers, 43.20 % for civil workers, 39.68 % for millwrights, 39.46 % for carpenters, 31.64 % for electricians, and 30.06 % for pipefitters. Although more data is required for these values to be statistically validated, it is clear that as work becomes more manual and complex, more preplanning is required, which leads to a decrease in the direct work percentage. It should be noted that work requiring more manpower and less machinery also necessitates more personal time, such as more rest and/or more waiting to obtain information from foremen; as shown in Figure 94, the amount of personal time spent by pipefitters is greater than that spent by operators. It may be concluded that the type of trade, the complexity of the work, the type of project, and other factors that affect labourers' work may all affect the desired target rate, so it is important that all of these factors be considered when the target rate is set.

Chapter 5: Conclusions & Recommendations

5.1 Conclusions

The applicability of Activity Analysis has been demonstrated through three case studies at industrial construction sites in Canada. The application of Activity Analysis on these sites indicates the feasibility of computing the activity rates of the workers, of identifying productivity barriers, and of determining the causes. The data analyzed shows an improvement in the direct work rate following the initial studies at each site and also that Activity Analysis correlates with the direct work rate.

Although this method was successful during the implementation phase and significant results were achieved, it is important to set realistic activity rates to avoid increasing the direct work rate beyond feasible levels by illogically attempting to decrease other activity rates or to expect less from what workers can actually do during working hours. Experience has shown that setting logical goals as an approach towards improvement has been always successful. Hence, Activity analysis as a continuous procedure is not excluded from this fact. In order to set a target rate for each activity category and trade, it is important for the managerial level to identify factors affecting labours work on site. These factors may vary from one project to another, and it should be identified for each project accordingly.

An Adaptive Inference-based model known as “ANFIS” was introduced as a procedure for obtaining logical target rates. An ANFIS-based estimation tool can account for imprecision, uncertainty, and non-linearity characteristics of activity rate measurements as well as target rate estimation. This model potentially provides accurate results. However, based on a set of 65 data points tested in this model it is not yet applicable in practice. While this tool proved to be easy and feasible to use, and it is flexible enough to include or exclude different factors beyond managerial level that affect productivity on site, in order to obtain expected rates, it requires much larger data set to be accurate and useful. Of more practical use were the three alternative methods explored for setting target rates: (1) Average, (2) Desired Quartile, (3) Optimal Value. Choice of the most appropriate method depends on the company values, culture, and managerial preferences.

5.2 Recommendations for future Research

Little has been published about Activity Analysis as a continuous productivity improvement tool and nothing has been yet been published with respect to an ANFIS-based estimation tool for setting target rates for different categories. At this point, only the procedure and a method of using this ANFIS model have been explained. Due to the lack of a research database, the model was not effectively validated. It is therefore important to gather sufficient data points on site based on predefined factors and to record the information for each site as a database. These steps will help managers to follow work trends, make comparisons, attempt to achieve the target rates based on known factors, and to know what to expect during variable circumstances. Adequate data sets are essential. Data points need to be extensive enough to cover all clusters so that a more precise target rate can be determined, and this procedure also requires a sufficient amount of time. The data points must represent different trades, different weather conditions, different locations, different project stages, different types of projects, etc.

It is important to identify the obstacles to the use of the Activity Analysis tool and also to find solutions for each one. Future research might therefore include the following:

1. Developing an easier technique for data collection to replace walking around with a clipboard all day,
2. Defining methods of tracking and defining different trades without identifiers,
3. Minimizing the impact of the observers on site,
4. Determining a correlation between the direct work rate and the productivity factor, and
5. Improving the procedure for implementing the recommendations, such as finding ways of more effectively convincing personnel on site to implement the recommendations.

References

- Business Roundtable (BRT). "More construction for the money: Summary report of the construction industry cost effectiveness project". (1983). Business Roundtable, Newyork.
- Ahuja, H. N., & Campbell, W. J. (1988). *Estimating From concept to completion*.
- Ballard, G., & Howell, G. (1998). What kind of production is construction. *Proceedings IGLC*, Guaruja, Brazil.
- Banik, G. (1999). Construction productivity improvement. *proc., 35th Annual Con., Associated Schools Of Construction.*, 165-178.
- Bertelsen, S. (2003). Construction as a complex system. *Proc., Int. Group for Lean Construction 11th Annual Conf.*, 11-23.
- Bledsoe, J. D. (1992). *Successful Estimating Methods*.
- Chiu, S. (1994). Fuzzy model identification based on cluster estimation. *J. Intell Fuzzy Syst.*, 2(3), 267-278.
- Clarkson H. Oglesby, H. W. (1989). *Productivity Improvement in Construction*.
- Crawford, P., & Vogl, B. (2006). Measuring productivity in the construction industry. *Building Research & Information*, 34(3), 208-219.
- Dai, J., Goodrum, P., & Maloney, W. (2009). Construction Craft workers' Perception of the Factors Affecting Their Productivity. *ASCE*, 135(3), 217.
- Derwin, F. J. (1982). *Construction Productivity*. New york: Elsevier Science Publishing.

- Eddy M. Rojas, P. A. (2003). Discussion of "Is Construction Labor Productivity Really Declining ?". *ASCE*.
- Eddy M. Rojas, P. A. (2003). Is construction Labor Productivity Really Declining ? *Construction Engineering and Management*.
- Elliot, Chirkov, Kim, & Sheldon. (2010). Setting, elaborating, and reflecting on personal goals improves academic performance. *The Journal of applied psychology*, 95(2), 255-264.
- Gale, E. (2004). The Hawthorne studies-a fable for our times? *QJM*, 97(7), 439-449.
- Gong, J., Borcharding, J., & Caldas, C. (2008). Assessment of Direct Work Utilization at the Workface in the U . S . Construction Industry (1972-2008). *Construction*, 960-969.
- Gong, J., D. Borcharding, J., & H. Caldas, C. (2008). Assessment of Direct Work Utilization at the Workface in the U.S Construction Industry (1972-2008). 960-969.
- Goodrum, P., & Haas, C. (2002). Partial Factor Productivity and Equipment Technology Change at Activity Level in U.S. Construction Industry. *Journal of Construction Engineering and Management*, 128(6), 463.
- Goodrum, P., Haas, C., & Glover, R. (2002). The divergence in aggregate and activity estimates of US construction productivity. *Construction Management and Economics*, 20(5), 415-423.
- Gouett, M., Haas, C., Goodrum, P., & Caldas, C. (2012). Activity Analysis for Direct-work Rate Improvement in Construction. *Journal of Civil Engineering and Management*.
- Haas, C., Borcharding, J., Allmo, E., & Goodrum, P. (1999). "U.S construction labor productivity trends, 1970-1988." Rep. No. 7. *Center for Construction Industry, University of Texas at Austin, Austin, Tex.*

Hendrickson, C. (2008). *Project Management for Construction*.

Henry W. Parker, C. H. (1972). *Methods Improvement for Construction Managers*.

Jame G Zack, et al. (2004). Estimating Lost Labor Productivity in Construction Claims. *aace*.

Jang, J. (1992). Self-learning fuzzy controllers based on temporal backpropagation. *IEEE Trans. Neural Netw.*, 3(5), 714-723.

Jang, J. (1993). ANFIS: Adaptive-network-based fuzzy inference system. *IEEE Trans. Syst. Man Cyber.*, 23(3), 665-685.

Jenkins, J., & Orth, D. (2003). Productivity improvement through sampling. *AACE International Transactions*.

Construction Industry Institute, "Guide to Activity Analysis", R2525-2a, Construction Industry Institute, Austin, Tex. (July 2010).

Kellogg, J., Howel, G., & Taylor, D. (1981). Hierarchy model of construction productivity. *Constr. Div.*, 107(1).

Koskela, L. (2002). The theory of project management: "Explanation to novel methods". *Proc., Int. Group for Lean Construction 10th Annual Conference*.

Laitinen, H., & Ruohomaki, I. (1996). The effects of feedback and goal setting on safety performance at two construction sites. *Pergamon*.

Levitt, S., & List, J. (2009). Was there Really a Hawthorne Effect at the Hawthorne Plant? An Analysis of the Original Illumination Experiments. *National Bureau of Economic Research, Working Paper 15016*.

- Liou, F., & D.Borcherding, J. D. (1986). Work Sampling Can Predict Unit Rate Productivity. *ASCE*, 90-103.
- McDonald, D., & Zack, J. (2004). Estimating Lost Labor Productivity in Construction Claims. *AACE International Recommended Practice No. 25R-0*.
- Morisano, D., Phil, R. O., Shore, B. M., Hirsh, J. B., & Peterson, J. B. (2011). Setting, Elaborating, and Reflecting on Personal Goal Academic Performance. *Journal of Applied Psychology*.
- Moslehi, O., Hegazy, T., & Fazio, P. (1991). Neural networks as tools in construction. *Journal of Construction Engineering and Management*, 117, 4, 606-625.
- Myatt, G. (2007). *Making Sense of Data*. New Jersey.
- Oglesby, C. H. (1989). *Productivity Improvement In Construction*. McGraw-Hill.
- Pande, P., & Holpp, L. (2002). *What is Six Sigma?* New york: McGraw-Hill.
- Pheng, L. S., & Hui, M. S. (2004). Implementing and Applying Six Sigma in Construction. *Managing*, 482-489.
- Picard, H. E. (2002). Construction process measurement & improvement. *Proceedings from the 10th Conference of the International Group for Lean Construction* , Gramado, Brazil.
- Rogge, D., & Tucker, R. (1982). Foremen-delay surveys: Work sampling & output. *ASCE*, 108 (CO 4), 557-591.
- Salem, O., Solomon, J., Genaidy, A., & Minkarah, I. (2006). Lean Construction: From Theory to Implementation. *Journal of Management in Engineering*, 22(4), 168.
- Shamji Dedhia, N. (2005). Six Sigma Basics. *Total Quality Management*, 16(5), 567-574.

- Thomas, H. (1991). Labor Productivity and work sampling the bottom line. *Journal of Construction Engineering and Management*, 117(3), 423-444.
- Thomas, H. R. (1992). Labor Productivity and Work Sampling. *ASCE*.
- Thomas, H. R. (1995). Labour Productivity and Work Sampling: The Bottom Line. *Engineering*, 117, 3, 423-444.
- Thomas, H., & Daily, J. (1983). Crew Performance Via Activity Sampling. *Journal of Construction Engineering and Management*, 109(2), 309.
- Thomas, H., Maloney, W., & Horner, R. E. (1990). Modeling Construction Labor Productivity. *Journal of Construction Engineering and Management*, 116(4), 705.
- Tucker, B., & Asce, F. (1986). Management of Construction Productivity. *Journal of Management*, 2(3), 148-156.
- Westney, R. E. (1997). *The Engineer's Cost Handbook*.
- Wiese, B., & Freund, A. (2005). Goal progress makes one happy, or does it? Longitudinal findings from the work domain. *Journal of Occupational and Organizational Psychology*, 78, 287-304.
- Yousefi, S., Hegazy, T., Capurro, R., & Attalla, M. (2008). System of multiple ANNs for online planning of numerous building improvements. *Journal of Construction Engineering and Management*, 134, 5, 342-351.

Appendix 1: Sample Calculation

The following is intended to illustrate the overall activity rate calculations for each study and the hourly distribution of the activity rates. Also included are calculations for the error and confidence levels. All calculations are based on calculations from research performed previously by Chris Gouett based on the "Activity Analysis Guide". Therefore, the calculation procedure has not been included and refers to those instructions.

Complete Data Entry Table (LB I)

	Time	7:00 8:00	8:00 9:00	9:00 10:00	10:00 11:00	11:00 12:00	12:00 1:00	1:00 2:00	2:00 3:00	3:00 4:00	4:00 5:00	Activity Totals	Percent of Obs.	Error for Each Activity Confidence level 95%	Z _{α/2}	α	A c t u a l C o n f i d e n c e L e v e l = 9 9 . 9 5 8 %
Direct Work	Day1	59	90	82	45	82	34	100	51	59	13	615	29.86979	0.005292	45.368844	0.00006	
	Day2	38	61	37	33	94	32	56	72	38	58	519					
	Day3	40	70	65	74	67	56	80	78	61	73	664					
	Day4	27	52	66	59	39	35	87	50	32	26	473					
Prep Work	Day1	32	58	24	5	11	5	10	3	11	5	164	7.483888	0.001749	137.262010	0.00006	
	Day2	29	12	18	9	14	11	18	10	15	8	144					
	Day3	35	6	10	14	22	12	8	30	7	14	158					
	Day4	28	21	9	9	6	7	13	6	2	2	103					
Tools/Equip	Day1	19	5	9	13	5	7	20	6	7	5	96	4.485072	0.001082	221.847409	0.00006	
	Day2	7	12	11	6	19	4	8	10	7	8	92					
	Day3	21	16	16	5	11	3	7	6	5	9	99					
	Day4	10	6	6	6	9	7	4	4	0	2	54					
Mat'l Hand	Day1	21	35	26	18	21	14	17	14	17	19	207	9.469946	0.002166	110.854855	0.00006	
	Day2	24	24	8	20	29	6	28	27	7	30	203					
	Day3	30	31	12	20	26	11	19	34	8	8	199					
	Day4	21	22	13	7	13	19	10	7	2	2	116					
Waiting	Day1	19	71	67	25	47	27	48	12	26	24	366	16.78285	0.008528	68.048174	0.00006	
	Day2	44	64	38	35	56	15	41	39	44	30	406					
	Day3	26	59	23	25	31	27	43	30	26	13	303					
	Day4	26	47	37	24	19	12	19	17	3	2	201					
Travel	Day1	49	63	63	45	77	41	49	33	30	22	472	23.42496	0.004532	52.982063	0.00006	
	Day2	92	46	39	40	66	27	41	42	33	57	483					
	Day3	70	46	47	24	49	45	38	51	22	32	424					
	Day4	51	53	53	34	37	51	38	42	28	15	402					
Personal	Day1	9	19	12	4	20	14	18	28	18	24	166	8.483493	0.001961	122.411113	0.00006	
	Day2	13	9	30	1	20	10	11	10	11	34	149					
	Day3	10	5	25	12	13	26	13	23	15	32	174					
	Day4	20	5	19	19	11	35	14	19	5	9	156					
	Hourly	870	1003	865	631	914	593	858	754	539	576	7603	Total	0.020311		0.00042	

Determining an adequate sample size is critical to the accuracy of the work sampling study. As more samples are collected, the results become more accurate as the sampling error is reduced. However, there is a balance between statistical accuracy and the cost to collect the samples. In most industries, an error of ± 5 % at a confidence level of 95 % is generally acceptable. The spreadsheet above was set up in order to determine the overall category percentages, as well as the actual confidence level. The confidence level

for each activity rate may be determined using various equations. However, in this calculation, $Z_{\alpha/2}$ is isolated, and the error is set to 5.0 %, which leads to a 95 % confidence level. It should be stated that regardless of population size, the sample size remains 510. Since the accumulation of observations is 15 times more than 510, the study becomes statistically more accurate and an actual confidence level of 99.958 % was attained.

Hourly Activity Rates

	7:00 8:00	8:00 9:00	9:00 10:00	10:00 11:00	11:00 12:00	12:00 1:00	1:00 2:00	2:00 3:00	3:00 4:00	4:00 5:00
Direct Work	18.8506	27.2183	28.9017	33.439	30.8534	26.4755	37.6457	33.2891	35.2505	29.5139
Prep Work	14.2529	9.67099	7.05202	5.86371	5.79869	5.90219	5.71096	6.49867	6.49351	5.03472
Tools/Equip	6.55172	3.88833	4.85549	4.75436	4.814	3.54132	4.54545	3.44828	3.52505	4.16667
Mat'l Hand	11.0345	11.1665	6.82081	10.3011	9.73742	8.4317	8.62471	10.8753	6.30798	10.2431
Waiting	13.2184	23.5294	19.0751	17.2742	16.7396	13.6594	17.5991	12.9973	18.3673	11.9792
Travel	30.1149	20.7378	23.3526	22.6624	25.0547	27.656	19.3473	22.2812	20.9647	21.875
Personal	5.97701	3.78863	9.9422	5.70523	7.00219	14.3339	6.52681	10.6101	9.09091	17.1875

Each column represents one hour, totaling 100 % of the activity. The maximum rate for each category is shown in red.

Hourly Confidence Levels

	$Z_{\alpha/2}$ 7:00 8:00	$Z_{\alpha/2}$ 8:00 9:00	$Z_{\alpha/2}$ 9:00 10:00	$Z_{\alpha/2}$ 10:00 11:00	$Z_{\alpha/2}$ 11:00 12:00	$Z_{\alpha/2}$ 12:00 1:00	$Z_{\alpha/2}$ 1:00 2:00	$Z_{\alpha/2}$ 2:00 3:00	$Z_{\alpha/2}$ 3:00 4:00	$Z_{\alpha/2}$ 4:00 5:00
Direct Work	7.11	6.33	5.26	3.54	5.36	3.81	4.57	4.24	2.95	3.46
Prep Work	8.90	14.35	16.50	14.29	20.92	13.35	19.92	15.51	11.10	15.06
Tools/Equip	17.76	33.55	23.41	17.42	24.93	21.70	24.72	28.31	19.81	18.03
Mat'l Hand	11.08	12.64	17.01	8.54	13.00	9.60	13.61	9.72	11.40	7.83
Waiting	9.48	6.97	7.00	5.52	8.20	6.29	7.40	8.33	4.49	6.83
Travel	5.17	7.63	6.04	4.50	6.08	3.70	6.87	5.44	4.07	4.21
Personal	19.35	34.40	12.08	14.66	17.54	6.04	17.58	9.94	8.15	5.06
Confidence Level %	99.96	99.96	99.96	99.92	99.96	99.93	99.96	99.96	99.65	99.91

The bottom row demonstrates that the confidence level for each hour was greater than 99.5 %, which indicates a very small percentage of error in these studies.

Complete Data Entry Table (DNI)

	Time	7:00 8:00	8:00 9:00	9:00 10:00	10:00 11:00	11:00 12:00	12:00 1:00	1:00 2:00	2:00 3:00	3:00 4:00	4:00 5:00	Activity Totals	Percent of Obs.	Error for Each Activity Confidence level 95%	Z _{α/2}	α	Actual Confidence Level = 99.958%
Direct Work	Day1	52	65	38	89	80	53	80	65	58	35	615	28.44981	0.005369	44.722917	0.00006	
	Day2	37	80	63	88	55	20	106	43	41	20	553					
	Day3	63	77	41	68	50	25	64	44	57	31	520					
	Day4	30	77	25	49	48	31	34	25	31	34	384					
Prep Work	Day1	29	23	38	17	15	14	22	7	15	8	188	10.07826	0.002390	100.454615	0.00006	
	Day2	34	24	20	30	24	7	24	13	17	6	199					
	Day3	42	35	9	22	12	9	25	6	5	13	178					
	Day4	38	20	21	14	12	14	10	9	17	14	169					
Tools/Equip	Day1	14	10	0	9	9	3	7	7	6	4	69	4.352602	0.001098	218.674534	0.00006	
	Day2	5	8	6	16	5	4	10	6	10	7	77					
	Day3	12	8	4	9	10	5	13	14	9	11	95					
	Day4	10	6	4	4	16	7	9	7	7	6	76					
Mat'l Hand	Day1	33	21	10	15	15	22	11	24	7	21	179	8.828779	0.002123	113.099814	0.00006	
	Day2	34	13	18	20	11	4	19	8	12	15	154					
	Day3	29	29	11	18	7	4	11	17	9	12	147					
	Day4	25	19	4	16	29	11	25	12	12	10	163					
Waiting	Day1	40	36	22	27	32	15	23	23	18	19	255	13.31869	0.003045	78.855760	0.00006	
	Day2	37	36	25	41	26	11	29	16	16	14	251					
	Day3	23	31	13	31	43	19	46	21	34	31	292					
	Day4	22	25	17	21	15	23	6	13	18	12	172					
Travel	Day1	70	44	41	53	76	42	33	64	35	51	509	23.98737	0.004809	49.928895	0.00006	
	Day2	57	45	74	59	64	18	39	53	32	39	480					
	Day3	68	60	57	45	32	22	50	32	27	24	417					
	Day4	44	47	43	21	29	31	35	25	37	29	341					
Personal	Day1	27	14	21	17	31	18	16	24	33	20	221	10.98448	0.002579	93.105414	0.00006	
	Day2	23	32	46	14	26	5	23	15	13	25	222					
	Day3	24	12	36	9	16	7	14	20	6	24	168					
	Day4	26	21	31	13	8	21	7	18	21	23	189					
	Hourly	948	918	738	835	796	465	791	631	603	558	7283	Total	0.021412		0.00042	

The overall confidence level is 99.958 %, which indicates the accuracy of data gathering and observation.

Hourly Activity Rates

	7:00 8:00	8:00 9:00	9:00 10:00	10:00 11:00	11:00 12:00	12:00 1:00	1:00 2:00	2:00 3:00	3:00 4:00	4:00 5:00
Direct Work	19.1983	32.5708	22.6287	35.2096	29.2714	27.7419	35.9039	28.0507	31.0116	21.5054
Prep Work	15.0844	11.1111	11.9241	9.94012	7.91457	9.46237	10.2402	5.54675	8.95522	7.34767
Tools/Equip	4.32489	3.48584	1.89702	4.5509	5.02513	4.08602	4.93047	5.38827	5.3068	5.01792
Mat'l Hand	12.7637	8.93246	5.82656	8.26347	7.78894	8.8172	8.34387	9.66719	6.6335	10.3943
Waiting	12.8692	13.9434	10.4336	14.3713	14.5729	14.6237	13.1479	11.5689	14.262	13.6201
Travel	25.211	21.3508	29.1328	21.3174	25.2513	24.3011	19.8483	27.5753	21.7247	25.6272
Personal	10.5485	8.60566	18.1572	6.34731	10.1759	10.9677	7.58534	12.2029	12.1061	16.4875

Each column represents one hour, totaling 100 % of the activity. The maximum rate for each category is shown in red.

Hourly Confidence Levels

	Z _{a/2} 7:00 8:00	Z _{a/2} 8:00 9:00	Z _{a/2} 9:00 10:00	Z _{a/2} 10:00 11:00	Z _{a/2} 11:00 12:00	Z _{a/2} 12:00 1:00	Z _{a/2} 1:00 2:00	Z _{a/2} 2:00 3:00	Z _{a/2} 3:00 4:00	Z _{a/2} 4:00 5:00
Direct Work	7.64	5.22	5.27	4.58	4.81	2.90	4.30	3.91	3.52	4.13
Prep Work	9.25	11.62	8.78	11.66	13.65	6.78	10.76	15.06	9.24	10.25
Tools/Equip	28.64	34.11	49.57	24.03	20.85	14.83	21.09	15.47	15.00	14.63
Mat'l Hand	10.64	14.11	16.81	13.77	13.85	7.23	12.93	9.03	12.17	7.49
Waiting	10.57	9.56	9.87	8.48	7.99	4.66	8.66	7.71	6.16	5.93
Travel	6.28	6.83	4.47	6.22	5.27	3.16	6.22	3.95	4.43	3.66
Personal	12.56	14.59	6.21	17.56	10.89	5.95	14.10	7.36	7.08	5.07
Confidence Level %	99.96	99.96	99.96	99.96	99.96	99.58	99.96	99.95	99.92	99.94

The bottom row demonstrates that confidence level for each hour was greater than 99.5 %.

Complete Data Entry Table (LB II)

	Time	7:00 8:00	8:00 9:00	9:00 10:00	10:00 11:00	11:00 12:00	12:00 1:00	1:00 2:00	2:00 3:00	3:00 4:00	4:00 5:00	Activity Totals	Percent of Obs.	Error for Each Activity Confidence level 95%	Z _{a/2}	α	A c t u a l C o n f i d e n c e L e v e l =
Direct Work	Day1	31	45	32	43	53	33	50	21	31	48	387	35.05709	0.014685	16.350353	0.00006	
	Day2	29	39	34	48	35	24	30	31	21	31	322					
	Day3	18	38	33	36	38	26	56	24	23	43	335					
Prep Work	Day1	18	10	12	12	12	10	1	2	16	2	95	9.603761	0.005599	42.878838	0.00006	
	Day2	21	16	14	14	5	11	5	5	5	3	99					
	Day3	24	4	7	8	12	18	5	4	6	4	92					
Tools/Equip	Day1	6	4	10	6	6	3	7	3	3	6	54	6.514439	0.003928	61.124192	0.00006	
	Day2	11	10	4	5	4	5	7	4	7	9	66					
	Day3	12	9	9	4	10	8	8	3	0	11	74					
Mat'l Hand	Day1	22	9	12	14	7	8	6	4	22	15	119	7.488247	0.004468	53.735046	0.00006	
	Day2	12	4	5	9	3	4	3	3	11	2	56					
	Day3	4	7	3	4	6	3	9	2	3	7	48					
Waiting	Day1	9	12	11	12	12	8	12	9	9	7	101	10.98052	0.006305	38.082602	0.00006	
	Day2	25	19	11	4	5	6	8	3	19	10	110					
	Day3	14	20	5	6	12	9	9	7	8	26	116					
Travel	Day1	35	23	26	29	18	27	12	11	30	17	228	21.2223	0.010783	22.265836	0.00006	
	Day2	36	18	25	11	27	11	13	5	24	4	174					
	Day3	50	16	20	23	20	30	17	23	9	22	230					
Personal	Day1	3	18	9	2	13	2	6	17	3	8	81	9.133647	0.005353	44.852577	0.00006	
	Day2	4	2	13	7	11	12	3	4	13	4	73					
	Day3	11	10	13	6	22	10	8	12	21	5	118					
	Hourly	395	333	308	303	331	268	275	197	284	284	2978					Total

Hourly Activity Rates

	7:00 8:00	8:00 9:00	9:00 10:00	10:00 11:00	11:00 12:00	12:00 1:00	1:00 2:00	2:00 3:00	3:00 4:00	4:00 5:00
Direct Work	19.74684	36.63664	32.14286	41.91419	38.06647	30.97015	49.45455	38.57868	26.40845	42.95775
Prep Work	15.94937	9.00901	10.71429	11.22112	8.76133	14.55224	4.00000	5.58376	9.50704	3.16901
Tools/Equip	7.34177	6.90691	7.46753	4.95050	6.04230	5.97015	8.00000	5.07614	3.52113	9.15493
Waiting	12.15190	15.31532	8.76623	7.26073	8.76133	8.58209	10.54545	9.64467	12.67606	15.14085
Travel	30.63291	17.11712	23.05195	20.79208	19.63746	25.37313	15.27273	19.79695	22.18310	15.14085
Personal	4.55696	9.00901	11.36364	4.95050	13.89728	8.95522	6.18182	16.75127	13.02817	5.98592
Mat'l Hand	9.62025	6.00601	6.49351	8.91089	4.83384	5.59701	6.54545	4.56853	12.67606	8.45070

Hourly Confidence Levels

	Z $\alpha/2$ 7:00 8:00	Z $\alpha/2$ 8:00 9:00	Z $\alpha/2$ 9:00 10:00	Z $\alpha/2$ 10:00 11:00	Z $\alpha/2$ 11:00 12:00	Z $\alpha/2$ 12:00 1:00	Z $\alpha/2$ 1:00 2:00	Z $\alpha/2$ 2:00 3:00	Z $\alpha/2$ 3:00 4:00	Z $\alpha/2$ 4:00 5:00
Direct Work	3.1156412	1.7930831	1.7651462	1.5556844	1.7549696	1.566984	1.3751637	1.0392253	1.826659	1.4487391
Prep Work	3.6831777	5.0778379	4.0245333	3.8019526	5.1759379	2.6941037	8.9518229	4.6709268	4.1263698	11.56884
Tools/Equip	7.2580878	6.4737092	5.5717223	8.0492266	7.2879202	5.9675198	4.6705163	5.1105434	10.449956	4.2684675
Waiting	4.6252008	3.2093969	4.8138447	5.6248235	5.1759379	4.2699272	3.6439716	2.8257588	3.2070878	2.7629914
Travel	2.3236214	2.933991	2.1704784	2.299779	2.6217966	1.7691941	2.6564576	1.5509114	2.0565166	2.7629914
Personal	11.352394	5.0778379	3.822359	8.0492266	3.4577318	4.1087842	5.927062	1.7658382	3.133043	6.3081912
Mat'l Hand	5.6787073	7.3734099	6.3407361	4.6662183	8.994219	6.340195	5.619562	5.6481775	3.2070878	4.5886026
Confidence Level %	97.75	92.29	89.29	85.95	91.07	79.936	82.43	49.862	89.21	84.116

It should be noted that the lower confidence levels are due to deflated quantities of observations. Nearly all hours are about 90 %, with a maximum and minimum of 97.75 % and 49.86 %, respectively.

As noted in the first chart in this Appendix, the overall confidence level remains at 99.958 % because of the total number of observations taken.

Complete Data Entry Table (DN II)

	Time	7:00 8:00	8:00 9:00	9:00 10:00	10:00 11:00	11:00 12:00	12:00 1:00	1:00 2:00	2:00 3:00	3:00 4:00	4:00 5:00	Activity Totals	Percent of Obs.	Error for Each Activity Confidence level 95%	Z _{α/2}	α	Actual Confidence Level = 99.958%
Direct Work	Day 1,2,3	52	183	87	148	140	85	108	85	16	11	915	32.20697	0.014762	16.264710	0.00006	
Prep Work	Day 1,2,3	44	53	26	46	56	37	27	29	9	6	333	11.72122	0.006996	34.320369	0.00006	
Tools/Equip	Day 1,2,3	10	22	13	14	19	1	8	7	6	4	104	3.660683	0.002384	100.696779	0.00006	
Mat'l Hand	Day 1,2,3	23	34	21	32	32	14	28	28	3	4	219	7.708553	0.004810	49.916820	0.00006	
Waiting	Day 1,2,3	41	44	22	38	60	29	37	26	5	2	304	10.70046	0.006460	37.164617	0.00006	
Travel	Day 1,2,3	56	103	95	93	114	60	49	61	12	6	649	22.84407	0.011917	20.148303	0.00006	
Personal	Day 1,2,3	27	39	50	42	60	15	19	47	11	7	317	11.15804	0.006702	35.824085	0.00006	
	Hourly	253	478	314	413	481	241	276	283	62	40	2841	Total	0.054032		0.00042	

Hourly Activity Rates

	7:00 8:00	8:00 9:00	9:00 10:00	10:00 11:00	11:00 12:00	12:00 1:00	1:00 2:00	2:00 3:00	3:00 4:00	4:00 5:00
Direct Work	20.553	38.285	27.707	35.835	29.106	35.27	39.13	30.035	25.806	27.5
Prep Work	17.391	11.088	8.2803	11.138	11.642	15.353	9.7826	10.247	14.516	15
Tools/Equip	3.9526	4.6025	4.1401	3.3898	3.9501	0.4149	2.8986	2.4735	9.6774	10
Mat'l Hand	9.0909	7.113	6.6879	7.7482	6.6528	5.8091	10.145	9.894	4.8387	10
Waiting	16.206	9.205	7.0064	9.201	12.474	12.033	13.406	9.1873	8.0645	5
Travel	22.134	21.548	30.255	22.518	23.701	24.896	17.754	21.555	19.355	15
Personal	10.672	8.159	15.924	10.169	12.474	6.2241	6.8841	16.608	17.742	17.5

Hourly Confidence Levels

	Z $\alpha/2$ 7:00 8:00	Z $\alpha/2$ 8:00 9:00	Z $\alpha/2$ 9:00 10:00	Z $\alpha/2$ 10:00 11:00	Z $\alpha/2$ 11:00 12:00	Z $\alpha/2$ 12:00 1:00	Z $\alpha/2$ 1:00 2:00	Z $\alpha/2$ 2:00 3:00	Z $\alpha/2$ 3:00 4:00	Z $\alpha/2$ 4:00 5:00
Direct Work	1.93674	2.5288	1.95954	2.2451873	2.9138207	1.319525	1.44845	1.68339	0.40477	0.25078
Prep Work	2.20127	6.0608	5.16813	5.2159843	5.8447816	2.318084	3.90908	3.84625	0.62455	0.39216
Tools/Equip	8.33039	13.608	9.88984	15.763739	15.847095	72.90376	12.2578	14.6643	0.88664	0.55556
Mat'l Hand	3.82663	9.0434	6.28944	7.2224611	9.6816398	5.505633	3.78467	3.96799	1.68311	0.55556
Waiting	2.32891	7.1491	6.02412	6.1793857	5.5069597	2.84595	2.97192	4.23997	1.0453	1.05263
Travel	1.83492	3.5345	1.86008	2.9588792	3.3248674	1.611133	2.36274	2.09212	0.49652	0.39216
Personal	3.31741	7.9738	2.93174	5.6511517	5.5069597	5.161328	5.38208	2.55423	0.53103	0.34632
Confidence Level %	83.202	98.824	88.356	97.23	99.604	68.082	83.156	98.55562	13.08	-

Complete Data Entry Table (HN)

	Time	7:00 8:00	8:00 9:00	9:00 10:00	10:00 11:00	11:00 12:00	12:00 1:00	1:00 2:00	2:00 3:00	3:00 4:00	Activity Totals	Percent of Obs.	Error for Each Activity Confidence level 95%	Z $_{\alpha/2}$	α	Actual Confidence Level = 99.958%
Direct Work	Day 1,2,3	56	66	54	80	89	54	84	87	50	620	35.85888	0.025552	9.396622	0.00006	
Prep Work	Day 1,2,3	20	19	14	21	32	12	22	22	17	179	10.35281	0.010311	23.286824	0.00006	
Tools/Equip	Day 1,2,3	26	17	15	18	18	8	8	12	13	135	7.807981	0.007997	30.024301	0.00006	
Mat'l Hand	Day 1,2,3	11	11	5	10	22	5	14	9	17	104	6.015038	0.006280	38.230351	0.00006	
Waiting	Day 1,2,3	22	26	16	28	36	19	36	26	14	223	12.89763	0.012480	19.238232	0.00006	
Travel	Day 1,2,3	35	24	37	30	36	30	33	38	40	303	17.52458	0.016057	14.953155	0.00006	
Personal	Day 1,2,3	12	14	22	11	28	20	13	30	15	165	9.543088	0.009590	25.036539	0.00006	
	Hourly	182	177	163	198	261	148	210	224	166	1729	Total	0.088267		0.00042	

Hourly Activity Rates

	7:00 8:00	8:00 9:00	9:00 10:00	10:00 11:00	11:00 12:00	12:00 1:00	1:00 2:00	2:00 3:00	3:00 4:00
Direct Work	30.7692	37.2881	33.1288	40.404	34.0996	36.4865	40	38.8393	30.1205
Prep Work	10.989	10.7345	8.58896	10.6061	12.2605	8.10811	10.4762	9.82143	10.241
Tools/Equip	14.2857	9.60452	9.20245	9.09091	6.89655	5.40541	3.80952	5.35714	7.83133
Mat'l Hand	6.04396	6.21469	3.06748	5.05051	8.42912	3.37838	6.66667	4.01786	10.241
Waiting	12.0879	14.6893	9.81595	14.1414	13.7931	12.8378	17.1429	11.6071	8.43373
Travel	19.2308	13.5593	22.6994	15.1515	13.7931	20.2703	15.7143	16.9643	24.0964
Personal	6.59341	7.9096	13.4969	5.55556	10.728	13.5135	6.19048	13.3929	9.03614

Hourly Confidence Levels

	Z $\alpha/2$ 7:00 8:00	Z $\alpha/2$ 8:00 9:00	Z $\alpha/2$ 9:00 10:00	Z $\alpha/2$ 10:00 11:00	Z $\alpha/2$ 11:00 12:00	Z $\alpha/2$ 12:00 1:00	Z $\alpha/2$ 1:00 2:00	Z $\alpha/2$ 2:00 3:00	Z $\alpha/2$ 3:00 4:00
Direct Work	1.0679861	0.9461563	0.9197135	1.0278591	1.451821	0.7983136	1.09375	1.1787298	0.9858397
Prep Work	2.3258364	2.3089744	2.5951264	2.6104358	3.0328161	2.4829902	2.7988999	3.1614041	2.257351
Tools/Equip	1.8579167	2.5483608	2.4384837	2.99475	5.0810417	3.6180714	7.163521	5.5225157	2.8747461
Mat'l Hand	4.0062254	3.7960248	6.8524478	5.1611649	4.2267927	5.6674685	4.21875	7.2606098	2.257351
Waiting	2.1408267	1.7655479	2.30163	2.0384433	2.7437625	1.6533007	1.8480603	2.7290754	2.686969
Travel	1.4646667	1.8876746	1.1611827	1.9251964	2.7437625	1.1447006	1.9818952	1.9877306	1.134498
Personal	3.6939755	3.0374852	1.7451431	4.7170588	3.4065721	1.5829063	4.520207	2.4139656	2.5244459
Confidence Level %	73.227	74.354	53.734	81.653	83.802	60.398	88.0251	86.992	78.405