

Feedback and Cooperation in Wireless Networks

by

Mohammad Javad Abdoli Hoseinabadi

A thesis
presented to the University of Waterloo
in fulfillment of the
thesis requirement for the degree of
Doctor of Philosophy
in
Electrical and Computer Engineering

Waterloo, Ontario, Canada, 2012

© Mohammad Javad Abdoli Hoseinabadi 2012

I hereby declare that I am the sole author of this thesis. This is a true copy of the thesis, including any required final revisions, as accepted by my examiners.

I understand that my thesis may be made electronically available to the public.

Abstract

The demand for wireless data services has been dramatically growing over the last decade. This growth has been accompanied by a significant increase in the number of users sharing the same wireless medium, and as a result, *interference management* has become a hot topic of research in recent years. In this dissertation, we investigate feedback and transmitter cooperation as two closely related tools to manage the interference and achieve high data rates in several wireless networks, focusing on additive white Gaussian noise (AWGN) interference, X, and broadcast channels.

We start by a one-to-many network, namely, the three-user multiple-input multiple-output (MIMO) Gaussian broadcast channel, where we assume that the transmitter obtains the channel state information (CSI) through feedback links after a finite delay. We also assume that the feedback delay is greater than the channel coherence time, and thus, the CSI expires prior to being exploited by the transmitter for its current transmission. Nevertheless, we show that this delayed CSI at the transmitter (delayed CSIT) can help the transmitter to achieve significantly higher data rates compared to having no CSI. We indeed show that delayed CSIT increases the channel degrees of freedom (DoF), which is translated to an unbounded increase in capacity with increasing signal-to-noise-ratio (SNR). For the symmetric case, i.e., with the same number of antennas at each receiver, we propose different transmission schemes whose achievable DoFs meet the upper bound for a wide range of transmit-receive antenna ratios. Also, for the general non-symmetric case, we propose transmission schemes that characterize the DoF region for certain classes of antenna configurations.

Subsequently, we investigate channels with distributed transmitters, namely, Gaussian single-input single-output (SISO) K -user interference channel and $2 \times K$ X channel under the delayed CSIT assumption. In these channels, in major contrast to the broadcast channel, each transmitter has access only to its own messages. We propose novel multiphase transmission schemes wherein the transmitters collaboratively align the past interference at appropriate receivers using the knowledge of past CSI. Our achievable DoFs are greater than one (which is the channel DoF without CSIT), and strictly increasing in K . Our results are yet the best available reported DoFs for these channels with delayed CSIT.

Furthermore, we consider the K -user r -cyclic interference channel, where each transmitter causes interference on only r receivers in a cyclic manner. By developing a new upper bound, we show that this channel has K/r DoF with no CSIT. Moreover, by generalizing our multiphase transmission ideas, we show that, for $r = 3$, this channel can achieve strictly greater than $K/3$ DoF with delayed CSIT.

Next, we add the capability of simultaneous transmission and reception, i.e., full-duplex operation, to the transmitters, and investigate its impact on the DoF of the SISO Gaussian K -user interference and $M \times K$ X channel under the delayed CSIT assumption. By proposing new cooperation/alignment techniques, we show that the full-duplex transmitter cooperation can potentially yield DoF gains in both channels with delayed CSIT. This is in sharp contrast to the previous results on these channels indicating the inability of full-duplex transmitter cooperation to increase the channel DoF with either perfect instantaneous CSIT or no CSIT. With the recent technological advances in implementation of full-duplex communication, it is expected to play a crucial role in the future wireless systems.

Finally, we consider the Gaussian K -user interference and $K \times K$ X channel with output feedback, wherein each transmitter causally accesses the output of its paired receiver. First, using the output feedback and under no CSIT assumption, we show that both channels can achieve DoF values greater than one, strictly increasing in K , and approaching the limiting value of 2 as $K \rightarrow \infty$. Then, we develop transmission schemes for the same channels with both output feedback and delayed CSIT, known as Shannon feedback. Our achievable DoFs with Shannon feedback are greater than those with the output feedback for almost all values of K .

Acknowledgements

I owe my deepest gratitude to my supervisor, Professor Amir K. Khandani, for this research opportunity and the perfect balance of support and independence during my studies. I have had a great opportunity to work with him and have learned a lot from him throughout the course of my PhD research.

I would like to thank the members of my dissertation committee, Professors Fady Alajaji, Steve Drekić, Patrick Mitran, and Pin-Han Ho, for taking the time out of their schedules to review my thesis and for providing me with their questions and comments.

I would like to specially acknowledge my friend and colleague, Akbar Ghasemi, for his collaboration and fruitful discussions we had on this research. I am grateful to my wonderful friend, Mahdi Zamani, for his kind support and for all the enjoyable moments I have had with him since the very beginning of my PhD studies. I would also like to extend my gratitude to all my friends specially Majid Safari, Amir H. Ghods, Pedram Ghodsnia, Hamid Ebrahimzad, and Babak Alipanahi with whom I have shared many happy moments.

I offer my utmost thanks to my parents for their unparalleled love and support throughout my life. I am also indebted to my brother and sisters for the helps and inspirations they granted me at every stage during my educational career.

Last but not least, I would like to express my warmest gratitude to my wife, Leila, for her endless support, patience, and encouragements, without which I would not have finished this long journey of PhD studies.

*To my love, Leila
for her dedicated support,
and my parents
for everything in my life*

Table of Contents

List of Tables	xii
List of Figures	xii
Acronyms	xv
Notations	xvi
1 Introduction	1
1.1 Feedback in Communication Channels	2
1.1.1 CSI Feedback	3
1.1.2 Output Feedback	4
1.2 Transmitter Cooperation	5
1.3 Dissertation Outline and Main Contributions	6
1.3.1 Chapter 2	6
1.3.2 Chapter 3	6
1.3.3 Chapter 4	7
2 Three-User MIMO Broadcast Channel with Delayed CSIT	9
2.1 System Model	10

2.2	(M, N, N, N) BC with Delayed CSIT	12
2.3	(M, N_1, N_2, N_3) BC with Delayed CSIT	22
2.4	Conclusion	36
3	SISO Interference and X Channels with Delayed CSIT	37
3.1	System Model	38
3.2	Main Results and Discussion	42
3.2.1	Main Results	42
3.2.2	Discussion	43
3.3	Proof of Theorem 3	46
3.3.1	The 3-user SISO Interference Channel with Delayed CSIT	46
3.3.2	The K -user SISO Interference Channel with Delayed CSIT	52
3.4	Proof of Theorem 4	59
3.4.1	The 2×3 SISO X Channel	59
3.4.2	The $2 \times K$ SISO X Channel	64
3.5	Cyclic SISO Interference Channel	67
3.5.1	K -user r -cyclic Interference Channel with no CSIT	68
3.5.2	K -user 3-cyclic Interference Channel with Delayed CSIT	69
3.6	Conclusion	74
4	SISO Interference and X Channels with Full-Duplex Transmitter Cooperation and Feedback	76
4.1	System Model	77
4.2	Illustrative Examples: Interference Channel	79
4.2.1	3-user Interference Channel	80

4.2.2	4-user Interference Channel	85
4.3	Illustrative Examples: X Channel	94
4.3.1	2×2 X Channel	94
4.3.2	3×3 X Channel	97
4.4	Main Results	106
4.4.1	Full-duplex Transmitter Cooperation and Delayed CSIT	106
4.4.2	Output Feedback	107
4.4.3	Shannon Feedback	107
4.4.4	Some Comments	108
4.5	SISO Interference and X Channels with Full-duplex Transmitter Cooperation and Delayed CSIT	110
4.5.1	Proof of Theorem 7	111
4.5.2	Proof of Theorem 8	114
4.6	SISO Interference and X Channels with Output Feedback	118
4.6.1	Proof of Theorem 9	119
4.6.2	Proof of Theorem 10	121
4.7	SISO Interference and X Channels with Shannon Feedback	123
4.7.1	Proof of Theorem 11	123
4.7.2	Proof of Theorem 12	125
4.8	Comparison and Discussion	129
4.9	Conclusion	131
5	Conclusion	134
5.1	Summary of Main Contributions	134
5.2	Future Research Directions	136

5.2.1	Upper Bounds	136
5.2.2	Finite SNR Regime: Capacity Characterization	136
5.2.3	Security Issues	137
Appendices		138
A Closed Form Expressions		139
A.1	Closed Form Expression for the Recursive Equation (3.58)	139
A.2	Closed Form Expression for the Recursive Equation (3.88)	142
A.3	Closed Form Expression for the Recursive Equations (4.44) and (4.56)	144
A.4	Closed Form Expression for the Recursive Equation (4.53)	145
A.5	Closed Form Expression for the Recursive Equation (4.66)	147
B Proofs of Linear Independence		149
B.1	Proof of Linear Independence in Phase 1 for the K -user IC with Delayed CSIT	149
B.2	Proof of Linear Independence in Phase m -I for the K -user IC and Phase m for the $2 \times K$ X Channel with Delayed CSIT	152
C Achievable DoF Limits for K-user IC and $2 \times K$ X Channel with Delayed CSIT		155
Bibliography		159

List of Tables

2.1	Different parameters together with the achievable DoF of the proposed schemes for (M, N, N, N) BC with delayed CSIT	21
3.1	Achievable DoFs for the K -user SISO interference channel with delayed CSIT	45
3.2	Achievable DoFs for the $M \times K$ SISO X channel with delayed CSIT	46

List of Figures

2.1	The normalized achievable DoF for (M, N, N, N) BC with delayed CSIT for $\bar{m} = \frac{M}{N} \leq 3.5$, and its comparison with the upper bound and also normalized channel DoFs with full CSIT and without CSIT.	22
2.2	Shape of the DoF region for $M \leq N_1$	24
2.3	Shape of the DoF region for $N_1 < M \leq N_2$	25
2.4	Shape of the DoF region for $N_2 < M \leq N_3$	26
2.5	Shape of the DoF region outer bound for $N_3 < M \leq N_1 + N_2$	27
2.6	Shape of the achievable DoF region for $N_3 < M \leq N_1 + N_2$ using Scheme 3 when the condition (2.74) does <i>not</i> hold. The region with corner point P_a is achievable.	33
3.1	K -user SISO interference channel	39
3.2	$M \times K$ SISO X channel	40
3.3	Our achievable DoF for the K -user SISO interference channel with delayed CSIT and $3 \leq K \leq 75$	44
3.4	Our achievable DoF for the SISO X channel with delayed CSIT and $2 \leq K \leq 75$	45
3.5	Block diagram of the proposed multiphase transmission scheme for the K -user IC, $K \geq 3$	53
3.6	Block diagram of the proposed multiphase transmission scheme for the $2 \times K$ X channel, $K \geq 2$	65

3.7	K -user 3-cyclic SISO IC.	67
3.8	Order-2 transmission graph for K -user 3-cyclic SISO IC with $K = 3L$	71
3.9	Order-2 transmission graph for K -user 3-cyclic SISO IC with $K = 3L + 1$ and $K = 3L + 2$	73
3.10	The achievable DoF for K -user 3-cyclic IC with delayed CSIT and the chan- nel DoFs with no CSIT and full CSIT.	75
4.1	Phase 1 of the transmission scheme for 3-user IC. Each coloured linear com- bination is the one which is (i) available at a receiver, (ii) not desired by that receiver, and (iii) desired by the other receivers.	83
4.2	Phase 2 of the transmission scheme for 3-user IC.	84
4.3	Phase 1 of the transmission scheme for 4-user IC. Each coloured linear com- bination is the one which is (i) available at a receiver, (ii) not desired by that receiver, and (iii) desired by two of the other receivers.	87
4.4	Phase 2 of the transmission scheme for full-duplex 4-user IC with delayed CSIT. Each coloured linear combination is the one which is (i) available at a receiver, (ii) not desired by that receiver, and (iii) desired by the other receivers.	90
4.5	Phase 2 of the transmission scheme for 4-user IC with Shannon feedback. Each coloured linear combination is the one which is (i) available at a re- ceiver, (ii) not desired by that receiver, and (iii) desired by the other receivers.	95
4.6	The transmission scheme for full-duplex 2×2 X channel with delayed CSIT. Each coloured linear combination is the one which is (i) available at a re- ceiver, (ii) not desired by that receiver, and (iii) desired by the other receiver.	97
4.7	Phase 1 of the transmission scheme for full-duplex 3×3 X channel with de- layed CSIT. Each coloured linear combination is the one which is (i) available at a receiver, (ii) not desired by that receiver, and (iii) desired by one of the other receivers.	99

4.8	Transmission scheme for 3×3 X channel with output feedback. Each coloured linear combination is the one which is (i) available at a receiver, (ii) not desired by that receiver, and (iii) desired by one of the other receivers.	101
4.9	Achievable DoFs for the K -user IC with output feedback.	122
4.10	Achievable DoFs for the K -user IC with Shannon feedback.	126
4.11	Achievable DoFs for the K -user IC with Shannon feedback, output feedback, full-duplex delayed CSIT, and delayed CSIT.	130
4.12	Achievable DoFs for the $M \times K$ X channel with delayed CSIT, with and without full-duplex transmitter cooperation.	132
4.13	Achievable DoFs for the $K \times K$ X channel with Shannon feedback, output feedback, full-duplex delayed CSIT, and delayed CSIT.	133

Acronyms

AWGN	Additive White Gaussian Noise.
BC	Broadcast Channel.
CSI	Channel State Information.
CSIT	Channel State Information at Transmitter.
DoF	Degrees of Freedom.
HK	Han and Kobayashi.
IC	Interference Channel.
i.i.d.	Independent and Identically Distributed.
MAC	Multiple Access Channel.
MIMO	Multiple-Input Multiple-Output.
MISO	Multiple-Input Single-Output.
SISO	Single-Input Single-Output.
SNR	Signal to Noise Ratio.

Notations

Boldface Lower-Case Letters	Vectors.
Boldface Upper-Case Letters	Matrices.
\mathbf{A}^T	Transpose of \mathbf{A} .
\mathbf{A}^\dagger	Conjugate transpose of \mathbf{A} .
$\mathbf{A} \circ \mathbf{B}$	Element-wise product of the matrices \mathbf{A} and \mathbf{B} .
$\mathcal{A} \cup \mathcal{B}$	Union of the sets \mathcal{A} and \mathcal{B} .
$\mathcal{A} \cap \mathcal{B}$	Intersection of the sets \mathcal{A} and \mathcal{B} .
$\mathcal{A} \setminus \mathcal{B}$	Difference of the sets \mathcal{A} and \mathcal{B} .
\mathbb{C}	The set of complex numbers.
\mathcal{C}	Capacity region.
$\mathcal{CN}(0, \sigma^2)$	Complex Gaussian distribution with mean 0 and variance σ^2 .
\mathcal{D}	DoF region.
DoF	DoF (Sum-DoF).
<u>DoF</u>	Achievable DoF.
$\mathbb{E}[X]$	Expected value of random variable X .
$f(n) = o(g(n))$	If and only if $\forall \epsilon > 0, \exists n_0 > 0, \forall n > n_0, f(n) \leq g(n) \cdot \epsilon$.
\mathbb{R}	The set of real numbers.
\mathbf{R}	Rate vector.
t	Time index.
$\lfloor x \rfloor$	The largest integer not greater than x .
$\lceil x \rceil$	The smallest integer not less than x .
\mathbb{Z}	The set of integers.

Chapter 1

Introduction

Since the pioneering work of Shannon in 1948 [46], the reliable communication between two or more nodes has been an active topic of research. While communication over point-to-point channels has been thoroughly studied from different perspectives such as capacity, reliability, delay, and complexity, complete characterization of the communication performance remains far from accomplished when it comes to multi-user networks. Indeed, except for some multi-user networks, such as multiple access channel (MAC) and special classes of broadcast channel (BC), the capacity of the majority of multi-user networks is still unknown. The main bottleneck which limits the performance of multi-user networks is the inherent interference between the users. In such networks, the interaction between users for utilization of a shared medium calls for efficient interference management techniques. The first study of these interactions is by Shannon [45] in the context of two-way channels.

The simplest case of a channel with multiple unicast information flows is the two-user interference channel (IC) introduced by Ahlswede [6], which consists of two transmitter-receiver pairs having interference on each other. Exact capacity characterizations under certain assumptions such as weak, strong, and very strong interference have been obtained for the two-user Gaussian IC [7, 14, 36, 40, 43]. The best inner bound for the capacity region of this channel is due to Han and Kobayashi (HK) rate-splitting scheme [24], which turned out to achieve the capacity of the two-user Gaussian IC to within one bit [18].

CHAPTER 1: INTRODUCTION

In networks with more than two information flows, such as K -user IC, $K \geq 3$, (which is a network with K unicast flows) and $M \times K$ X channel (which is a network with M broadcast flows), traditional schemes such as HK scheme fail to manage multiple interference terms observed at each receiver. The new concept of *Interference Alignment*, introduced in [32] for a class of two-user multiple-input multiple-output (MIMO) X channel, has proved to efficiently manage the aggregated interference simultaneously at all receivers. The idea behind the interference alignment is to design the transmitted signals such that the total interference observed by each receiver occupies only a predetermined fraction of the whole degrees of freedom (DoF) available at that receiver. Using this technique, the DoFs of the fading K -user single-input single-output (SISO) IC and $M \times K$ SISO X channel were shown to be $K/2$ and $MK/(M + K - 1)$, respectively [10, 12], and the DoF region of the two-user MIMO X channel was characterized in [29]. As a first order approximation of the channel capacity, the DoF of a channel characterizes its sum-capacity in high signal-to-noise-ratio (SNR) regime, i.e.,

$$C(\text{SNR}) = \text{DoF} \times \log_2(\text{SNR}) + o(\log_2(\text{SNR})), \quad (1.1)$$

where $C(\text{SNR})$ is the sum-capacity for a given SNR and DoF is the channel sum-DoF, or simply, DoF. The interference alignment technique has been also extended to obtain the DoF of some classes of the constant (time-invariant) fading SISO K -user IC in [17] using number theoretical arguments.

1.1 Feedback in Communication Channels

The crucial role of feedback in reliability, throughput, and complexity of transmission over communication networks has made it an indispensable ingredient of all modern communication systems. In spite of the first result by Shannon that shows the capacity of a memoryless point-to-point channel is not increased with feedback [44], there are various results affirming the significant effect of feedback on other performance criteria such as complexity and error probability of this channel [9, 19, 41, 42] (see also [20] and references therein). On the other hand, feedback has proved to enlarge the capacity region of several multi-user channels. The capacity regions of (non-fading) Gaussian MAC and BC

CHAPTER 1: INTRODUCTION

are enlarged with noiseless output feedback as shown in [37, 38] using generalizations of Schalkwijk and Kailath (SK) scheme [41, 42]. It was shown in [8], using SK scheme and dirty-paper coding, that even a single output feedback link from one of receivers enlarges the capacity region of the two-user Gaussian BC. The capacity region enlargements for discrete memoryless multiple access and broadcast channels with access to noiseless output feedback are reported in [15, 47, 58].

In non-fading Gaussian channels, each receiver observes only its output of channel, and thus, any type of feedback is a function of the output(s) of channel. In fading Gaussian channels, however, since it is commonly assumed that each receiver obtains the channel state information (CSI) instantaneously and perfectly through the channel estimation phase, the channel output(s) and/or the CSI can be fed back to the transmitter(s). Without any feedback, and hence, without CSI at any transmitter (no CSIT), the capacity regions of SISO fading two-user broadcast and two-user Z -interference channels have been characterized to within constant gaps [53, 65]. The K -user multiple-input single-output (MISO) broadcast channel with no CSIT was studied in [28]. Other works include [27, 66] which investigate the DoF region of two-user MIMO broadcast and interference channels without CSIT. It was shown in [56] that a large class of MISO multi-user channels including broadcast, interference, X, and cognitive radio channels can achieve no more than one degree of freedom (DoF) with no CSIT.

1.1.1 CSI Feedback

When there is CSI feedback to transmitter(s) *and* the channel variations are not too fast compared to the feedback delay, it is commonly assumed that the CSI obtained through feedback links is valid at least over the current channel use, and hence, the transmitter(s) have access to perfect and instantaneous CSI (full CSIT). Under constant CSI and full CSIT assumption, the capacity region (and hence, the DoF region) of the MIMO BC was characterized in [59], where the author showed the capacity region can be achieved by dirty-paper coding. The DoF characterization of the SISO IC and X channel [10, 12] is based on time-varying CSI and full CSIT assumption. It is important to note that in all the conventional interference alignment techniques, the full CSIT assumption is central, since

CHAPTER 1: INTRODUCTION

the transmitters require the current CSI to design their transmitted signals. However, if the feedback delay is greater than the channel coherence time, the CSI obtained through feedback links is often outdated. This makes the “full CSIT assumption” practically implausible, since the CSIT expires prior to the beginning of each channel use.

A model which makes a bridge between the two extremes of full and no CSIT was proposed in [33] in the context of MISO BC. In this model, being referred to as *delayed CSIT*, the transmitter knows the CSI perfectly but with a finite delay. It was established that even the outdated CSIT yields DoF gains in the MISO BC. In particular, the MISO BC with K receivers and $M \geq K$ antennas at transmitter was shown to have $K/(1 + 1/2 + \dots + 1/K)$ DoF with delayed CSIT, which is greater than one and scales with K . The DoF of two-user and three-user MIMO BC with delayed CSIT was then studied in [3, 55], where achievable and tight results were obtained. Initial achievable DoF results for the three-user SISO IC and two-user SISO X channel with delayed CSIT were reported in [35]. Their result was then improved for the two-user X channel in [23]. Achievable DoFs for the K -user SISO IC and X channel has been reported in [1, 2], which are still the best known DoF lower bounds for these channels with delayed CSIT. The DoF region of the two-user MIMO IC and sum-DoF of the two-user symmetric MIMO X channel were studied under delayed CSIT assumption in [21, 22, 57].

1.1.2 Output Feedback

It should be noted that the works of [8, 37, 38], as mentioned at the beginning of this section, assume that the CSI is fixed and known to all nodes (fixed and full CSIT assumption). Under the same assumption, the capacity region of the two-user SISO Gaussian IC with output feedback was characterized to within 2 bits in [48]. Generalizing SK and Ozarow’s feedback coding schemes, Kramer proposed transmission strategies for the K -user SISO Gaussian IC with output feedback in [30, 31], and the capacity of K -user symmetric cyclic Z-IC with output feedback was obtained in [49].

When there is no instantaneous CSIT, feedback still can help to attain DoF gains. In [35], the authors showed that the three-user SISO IC and two-user SISO X channel with no

CSIT can achieve respectively $6/5$ and $4/3$ DoF with output feedback. The two-user MIMO IC with delayed CSIT and output feedback, known as Shannon feedback, was studied in [50, 54], where its DoF region was characterized. In [4, 5], achievable DoFs were obtained for the K -user SISO IC and $K \times K$ X channels with output feedback (without CSIT) and also with Shannon feedback.

1.2 Transmitter Cooperation

Output feedback in multi-user channels with distributed transmitters, such as IC and X channel, naturally provides some level of transmitter cooperation. As such, there are connections between communication over these channels with feedback and that with transmitter cooperation. A common cooperation setup is to enable transmitters to operate in full-duplex mode, i.e., transmit and receive simultaneously, which is gaining increasing attention in communication industry due to recent advances in technology. The two-user IC with full-duplex transmitters (under full CSIT assumption) was investigated in [13, 25, 39, 52, 63]. In [13, 39, 63] achievable schemes are proposed based on further splitting the common and/or private information of the HK scheme into two parts, namely, non-cooperative and cooperative part. The cooperative part is decoded at the other transmitter as well to be able to cooperate in delivering the information to the desired receiver. By developing an upper bound the sum-capacity of the two-user Gaussian IC with full-duplex transmitters was obtained to within a constant number of bits in [39].

Moreover, it was shown in [11, 26] that under the full CSIT assumption, the full-duplex cooperation and/or output feedback cannot increase DoF of the Gaussian SISO K -user IC and $M \times K$ X channel. In other words, the full-duplex cooperation as well as output feedback can only yield “additive” capacity increase in the aforementioned channels when the full CSI is available at the channel nodes. With no CSIT also the full-duplex transmitter cooperation cannot help these channels to achieve more than one DoF, since the MISO broadcast channel DoF is equal to one with no CSIT[56]. However, the situation is different when the CSIT is delayed as reported in [4, 5], where it was shown that these channels can potentially achieve higher DoFs with full-duplex transmitter cooperation.

1.3 Dissertation Outline and Main Contributions

In this dissertation, we address communication over Gaussian multi-user networks with feedback and/or transmitter cooperation and with no instantaneous knowledge of CSI at the transmitter(s). The following summarizes the main contributions in this dissertation:

1.3.1 Chapter 2

Chapter 2 is dedicated to investigation of communication over the three-user MIMO broadcast channel with delayed CSIT. The main contributions of this chapter are as follows:

- **Symmetric Three-user MIMO BC with Delayed CSIT**

Different transmission schemes are proposed for the symmetric case, i.e., with M antennas at transmitter and N antennas at each receiver. The schemes are proved to be DoF optimal for $M \leq 2N$ and $M \geq 3N$ by showing that their achievable DoF meets the existing upper bound. For $2N < M < 3N$, our achievable DoF is very close to the upper bound, and is yet the best reported achievable DoF for this channel.

- **General Three-user MIMO BC with Delayed CSIT**

The general (not necessarily symmetric) case is also investigated for a class of three-user MIMO BCs with

$$M \leq \max\{N_1, N_2, N_3, \min(N_1 + N_2, N_2 + N_3, N_3 + N_1)\}, \quad (1.2)$$

where N_i is the number of antennas at receiver i , $1 \leq i \leq 3$. Two different transmission schemes are proposed, each of which is shown to be DoF region optimal for a range of antenna configurations.

1.3.2 Chapter 3

In this chapter, communication over the SISO interference and X channels are addressed under delayed CSIT assumption. The main contributions of this chapter are as follows:

- **Fully-connected K -user SISO IC with Delayed CSIT**

A multiphase transmission scheme is proposed for the SISO fully connected K -user IC with delayed CSIT that achieves DoF values greater than one and strictly increasing in K . For $K = 3$, $36/31$ DoF is achieved, which is strictly greater than the previously reported $9/8$ DoF in [35].

- **Cyclic K -user SISO IC with Delayed CSIT**

The K -user cyclic SISO IC is investigated. Inspired by a channel model introduced by Wyner [60], the K -user r -cyclic IC represents a set of K base stations located along a circle together with K mobile stations distributed around the base stations. Each transmitter causes interference on only $r - 1$ closest receivers in the array. We first show that K -user r -cyclic IC has K/r DoF with no CSIT. Then, we focus on $r = 3$ and show that this channel can achieve strictly more than $K/3$ DoF with delayed CSIT.

- **Fully-connected $2 \times K$ SISO X Channel with Delayed CSIT**

A multiphase transmission scheme is proposed for the $2 \times K$ SISO X channel with delayed CSIT. The achievable DoFs for this channel are greater than one and strictly increasing in K .

All achievable DoFs in this chapter are strictly greater than the previously reported DoFs for $K \geq 3$, and to date, are the best known achievable DoF results for the channels under consideration with delayed CSIT.

1.3.3 Chapter 4

In Chapter 4, we address the following problems:

- **Full-duplex Transmitter Cooperation and Delayed CSIT**

- **K -user SISO IC:** A transmission scheme is proposed whose achievable DoFs are strictly increasing in K and greater than our achievable DoFs for the same channel with delayed CSIT but without transmitter cooperation (cf. Chapter 3).

CHAPTER 1: INTRODUCTION

- **$M \times K$ SISO X Channel:** A transmission scheme is proposed that achieves DoFs strictly increasing in K and greater than our achievable DoFs of Chapter 3 for the $2 \times K$ X channel with delayed CSIT but without transmitter cooperation.

The results of this part are the first to show that full-duplex transmitter cooperation can potentially yield DoF gains in multi-user channels (in contrast to the full or no CSIT cases where it is known that full-duplex cooperation cannot increase the channel DoF).

- **Output Feedback**

By proposing different transmission schemes, achievable DoFs are obtained for the K -user SISO IC and $K \times K$ SISO X channel with output feedback (with no CSIT). The output feedback considered in this dissertation is indeed a “limited” output feedback in the sense that each transmitter is assumed to have output feedback from its own paired receiver (not all receivers). The achievable DoFs for both channels strictly increase with K and approach the limiting value of 2 as $K \rightarrow \infty$.

- **Shannon Feedback**

The Shannon feedback, which is a combination of output feedback and delayed CSIT, is also studied for both the K -user SISO IC and $K \times K$ SISO X channel. We achieve DoFs with Shannon feedback that are strictly increasing in K and greater than our achievable DoFs with output feedback for $K = 5$ and $K \geq 7$ in IC and $K \geq 3$ in X channel.

Our achievable DoFs under output or Shannon feedback are the first and yet the best known achievable results for both channels.

Chapter 2

Three-User MIMO Broadcast Channel with Delayed CSIT

In this chapter¹, we investigate a three-user MIMO Gaussian broadcast channel with i.i.d. fading. It is assumed that the channel state information (CSI) is fed back to the transmitter with a finite delay, a model which is referred to as *delayed CSIT* model throughout this dissertation. Hence, due to the feedback delay and i.i.d. fading, the CSI is completely outdated when obtained by the transmitter. We first study the three-user MIMO broadcast channel with the same number of antennas at each receiver in Section 2.2. We obtain achievable results on the degrees of freedom (DoF) of this channel and also show that our achievable DoF is tight for some ranges of transmit-receive antenna ratio. We then consider this channel in the general case of having an arbitrary (not necessarily equal) number of antennas at each receiver in Section 2.3. In this case, we propose transmission schemes and obtain their achievable DoF regions. We also identify transmit-receive antenna configurations for which our achievable DoF regions meet the outer bound, and thus, characterize the channel DoF region with delayed CSIT.

¹Part of the work in this chapter has been reported in [3]

2.1 System Model

We consider a three-user Gaussian MIMO broadcast channel (BC) with M antennas at the transmitter and N_j antennas at receiver j , $1 \leq j \leq 3$ (denoted by RX_j). We denote this channel as (M, N_1, N_2, N_3) BC. The input and output of this channel at time slot t , $t = 1, 2, \dots$, are related to each other by

$$\mathbf{y}^{[j]}(t) = \mathbf{H}^{[j]}(t)\mathbf{x}(t) + \mathbf{z}^{[j]}(t), \quad 1 \leq j \leq 3, \quad (2.1)$$

where $\mathbf{x}(t) = [x_1(t), x_2(t), \dots, x_M(t)]^T \in \mathbb{C}^M$ is the transmitted vector with average power constraint

$$\mathbb{E}[\mathbf{x}(t)^\dagger \mathbf{x}(t)] \leq P, \quad (2.2)$$

$\mathbf{y}^{[j]}(t) = [y_1^{[j]}(t), y_2^{[j]}(t), \dots, y_{N_j}^{[j]}(t)]^T \in \mathbb{C}^{N_j}$ is the received vector at RX_j , $\mathbf{H}^{[j]}(t)$ is the $N_j \times M$ channel matrix from the transmitter to RX_j , and $\mathbf{z}^{[j]}(t) = [z_1^{[j]}(t), z_2^{[j]}(t), \dots, z_{N_j}^{[j]}(t)]^T$ is the vector of zero-mean unit-variance complex Gaussian noise elements $z_n^{[j]}(t) \sim \mathcal{CN}(0, 1)$, $n = 1, 2, \dots, N_j$, at RX_j . The noise elements are i.i.d. across all receive antennas as well as time. Also, the channel coefficients are assumed to be i.i.d. across all nodes, antennas, and time. We define the CSI matrix $\mathbf{H}(t) \triangleq [(\mathbf{H}^{[1]}(t))^T, (\mathbf{H}^{[2]}(t))^T, (\mathbf{H}^{[3]}(t))^T]^T$. We make the following assumptions on the knowledge of CSI at different nodes:

Definition 1 (Delayed CSIT for BC). *RX_j , $1 \leq j \leq 3$, instantaneously knows the elements of $\mathbf{H}^{[j]}(t)$, while having access to the channel matrix of the other receivers with a finite delay. The transmitter has access to $\mathbf{H}(t)$ with a finite delay through noiseless feedback links from all receivers. Without loss of generality, one time slot delay is assumed throughout this dissertation.*

The transmitter wishes to communicate a message $W^{[j]} \in \mathcal{W}^{[j]} = \{1, 2, \dots, 2^{\tau R^{[j]}}\}$ of rate $R^{[j]}$ to RX_j over a block of τ time slots or channel uses. To do so, a block code of length τ is used by the transmitter, which is defined as follows:

Definition 2 (Block Code with Delayed CSIT). *A $(2^{\tau \mathbf{R}}, \tau)$ code of block length τ and rate $\mathbf{R} \triangleq [R^{[1]}, R^{[2]}, R^{[3]}]$ with delayed CSIT in the 3-user MIMO BC is a set of encoding*

CHAPTER 2: THREE-USER MIMO BC WITH DELAYED CSIT

functions $\{\varphi_{t,\tau}\}_{t=1}^\tau$, such that

$$\mathbf{x}(t) = \varphi_{t,\tau}(W^{[1]}, W^{[2]}, W^{[3]}, \{\mathbf{H}(t')\}_{t'=1}^{t-1}), \quad 1 \leq t \leq \tau, \quad (2.3)$$

together with three decoding functions $\psi_\tau^{[i]}$, $1 \leq i \leq 3$, such that

$$\hat{W}_\tau^{[i]} = \psi_\tau^{[i]}(\{\mathbf{y}^{[i]}(t)\}_{t=1}^\tau, \{\mathbf{H}(t)\}_{t=1}^{\tau-1}, \mathbf{H}^{[i]}(\tau)). \quad (2.4)$$

Defining the probability of error of a code as the probability that any of the receivers decodes its message incorrectly, we have the following definitions for an achievable rate and the capacity region:

Definition 3 (Achievable Rate, and Capacity Region). *For a given power constraint P , a rate tuple $\mathbf{R}(P)$ is said to be achievable if there exists a sequence $\{(2^{\mathbf{R}(P)}, \tau)\}_{\tau=1}^\infty$ of codes such that their probability of error goes to zero as $\tau \rightarrow \infty$. The closure of the set of all achievable rate tuples $\mathbf{R}(P)$ is called the capacity region of the channel with power constraint P and is denoted by $\mathcal{C}^{\text{BC}}(P)$.*

Definition 4 (DoF for Three-user BC with Delayed CSIT). *If $\mathbf{R}(P) \in \mathcal{C}^{\text{BC}}(P)$ is an achievable rate tuple for the (M, N_1, N_2, N_3) BC with delayed CSIT, then $\mathbf{d} = [d^{[1]}, d^{[2]}, d^{[3]}] \triangleq \lim_{P \rightarrow \infty} \frac{\mathbf{R}(P)}{\log_2 P}$ is called an achievable DoF tuple and $\underline{\text{DoF}}^{\text{BC}}(M, N_1, N_2, N_3) \triangleq d^{[1]} + d^{[2]} + d^{[3]}$ is called an achievable sum-DoF or simply achievable DoF. The closure of the set of all achievable DoF tuples is called the channel DoF region and denoted by $\mathcal{D}^{\text{BC}}(M, N_1, N_2, N_3)$, and the channel sum-DoF or simply DoF is defined as*

$$\text{DoF}^{\text{BC}}(M, N_1, N_2, N_3) \triangleq \max_{\mathbf{d} \in \mathcal{D}^{\text{BC}}(M, N_1, N_2, N_3)} d^{[1]} + d^{[2]} + d^{[3]}. \quad (2.5)$$

Using the fact that feedback does not enlarge the capacity region of a physically degraded broadcast channel, Maddah-Ali et al. in [34] developed an outer bound on the DoF region of a K -user MISO broadcast channels with delayed CSIT. By generalizing this idea to the MIMO case, Vaze et al. in [55] obtained an outer bound on the DoF region of a K -user MIMO broadcast channel with delayed CSIT. The following proposition presents this outer bound for $K = 3$:

CHAPTER 2: THREE-USER MIMO BC WITH DELAYED CSIT

Proposition 1 ([55]). *An outer bound to the DoF region of (M, N_1, N_2, N_3) BC with delayed CSIT is*

$$\mathcal{D}_{\text{outer}}^{\text{BC-dCSIT}}(M, N_1, N_2, N_3) \triangleq \left\{ (d^{[1]}, d^{[2]}, d^{[3]}) \mid d^{[j]} \geq 0, \quad \forall j, \right. \\ \left. \sum_{i=1}^3 \frac{d^{[\pi(i)]}}{\min(M, \sum_{j=i}^3 N_{\pi(j)})} \leq 1, \quad \forall \pi \right\}, \quad (2.6)$$

where π is a permutation of the set $\{1, 2, 3\}$.

Using this outer bound, and after some manipulations, we get the following upper bound on the DoF of (M, N, N, N) BC with delayed CSIT:

Proposition 2. *The DoF of (M, N, N, N) BC with delayed CSIT is upper bounded by*

$$\text{DoF}_{\text{upper}}^{\text{BC}}(M, N, N, N) \triangleq \frac{3}{\frac{1}{\min(M, N)} + \frac{1}{\min(M, 2N)} + \frac{1}{\min(M, 3N)}}. \quad (2.7)$$

The above upper bound can be explicitly expressed as follows:

$$\text{DoF}_{\text{upper}}^{\text{BC}}(M, N, N, N) = \begin{cases} M & M \leq N \\ \frac{3MN}{M+2N} & N < M \leq 2N \\ \frac{6MN}{3M+2N} & 2N < M \leq 3N \\ \frac{18}{11}N & M > 3N \end{cases}. \quad (2.8)$$

2.2 (M, N, N, N) BC with Delayed CSIT

In this section, we consider the (M, N_1, N_2, N_3) BC with $N_1 = N_2 = N_3 = N$ and with delayed CSIT. We will show how the delayed CSIT can be utilized to achieve DoF gains over the no CSIT case for some ratios M/N . The main idea lies behind the following observations: Since the transmitter has access to both past CSI and past transmitted information symbols, it perfectly knows the whole past interference at each receiver. Also,

CHAPTER 2: THREE-USER MIMO BC WITH DELAYED CSIT

an interference term at a receiver can be a useful piece of information for some other receivers about their information symbols. Therefore, retransmission of such interference terms not only aligns the interference at some receivers, but also provides other receivers with a desired piece of information about their information symbols.

Although the DoF region of a two-user MIMO BC with delayed CSIT with arbitrary number of antennas at each node has been fully characterized in [55], its DoF region or even its sum-DoF is not known when there is more than two receivers in the system. In this section, we will show that the upper bound of (2.8) is tight for $M \leq 2N$ and $M \geq 3N$. We also propose two achievable schemes for $2N < M < 3N$ that achieve DoF values very close to the upper bound. The following theorem summarizes our main results in this section:

Theorem 1. *For (M, N, N, N) BC with delayed CSIT,*

(a) *if $M \leq 2N$, then the upper bound of (2.8) is achievable. In other words, the channel DoF is equal to*

$$\text{DoF}^{\text{BC}}(M, N, N, N) = \frac{3M \min(M, N)}{2 \min(M, N) + M}; \quad (2.9)$$

(b) *if $2N < M \leq 3N$, then we have*

$$\text{DoF}^{\text{BC}}(M, N, N, N) \geq \max \left\{ \frac{12MN}{5M + 7N}, \frac{24MN}{15M + 2N} \right\}. \quad (2.10)$$

Remark 1. *The cases $M = 2N$ and $M = 3N$ are the scaled versions of the three-user MISO broadcast channel with two and three transmit antennas, respectively. These MISO channels have been studied in [33, 34], where their DoF has been shown to be $\frac{3}{2}N$ and $\frac{18}{11}N$, respectively. The DoF of the case $M > 3N$ is trivially equal to that of the case $M = 3N$, which is $\frac{18}{11}N$.*

Proof. For $M \leq N$, $\underline{\text{DoF}}^{\text{BC}}(M, N, N, N) = M$ is achievable using a time-division scheme. Indeed, for $M \leq N$, the outer bound region of Proposition 2 is achieved even without CSIT since $\min(M, N) = M$ (cf. [56]). Also, even with full CSIT, more than M DoF cannot be achieved in this range of M since $\min(M, 3N) = M$ (cf. [59]).

For $N < M \leq 3N$, we propose transmission schemes which compose of three distinct phases outlined as follows:

CHAPTER 2: THREE-USER MIMO BC WITH DELAYED CSIT

- *Phase 1* takes K_1 symbols from i.i.d. Gaussian codewords ($K_1/3$ symbols per receiver) and generates K_2 “order-2 symbols” in T_1 time slots. An order-2 symbol is defined as a symbol which is intended to be delivered to a pair of receivers. An order-2 symbol which is intended for RX_i and RX_j is denoted by $u^{[i,j]}$ and called an “ (i, j) -symbol”.
- *Phase 2* takes the K_2 order-2 symbols generated by the end of phase 1 ($K_2/3$ order-2 symbols for each pair of receivers) and generates K_3 “order-3 symbols” in T_2 time slots. An order-3 symbol is defined as a symbol which is intended to be delivered to all three receivers.
- *Phase 3* takes the K_3 order-3 symbols generated by the end of phase 2 and delivers them to all three receivers in T_3 time slots.

Since the proposed schemes differ only in their phase 1, we first describe phase 1 of each proposed scheme. The phases 2 and 3 will be described subsequently, once for all the schemes. We consider two disjoint regions $N < M \leq 2N$ and $2N < M \leq 3N$ separately:

Phase 1 ($N < M \leq 2N$):

- *Scheme 1*:

The transmitter transmits $K_1 = 6M$ symbols in $T_1 = 3$ time slots as follows: Let $\mathbf{u}_1^{[j]} \triangleq [u_1^{[j]}, u_2^{[j]}, \dots, u_M^{[j]}]^T$ and $\mathbf{u}_2^{[j]} \triangleq [u_{M+1}^{[j]}, u_{M+2}^{[j]}, \dots, u_{2M}^{[j]}]^T$ denote two vectors containing $2M$ symbols from an i.i.d. Gaussian codeword intended for RX_j , $1 \leq j \leq 3$. We call these symbols “information symbols” of RX_j . Each time slot is dedicated to two receivers where the transmitter transmits M linear combinations of the $2M$ information symbols of the corresponding receivers over its M antennas: In the first time slot, the transmitter transmits the vector

$$\mathbf{x}(1) = \mathbf{u}_1^{[1]} + \mathbf{u}_1^{[2]} = [u_1^{[1]} + u_1^{[2]}, u_2^{[1]} + u_2^{[2]}, \dots, u_M^{[1]} + u_M^{[2]}]^T. \quad (2.11)$$

The second and third time slots are dedicated to transmission of

$$\mathbf{x}(2) = \mathbf{u}_2^{[2]} + \mathbf{u}_1^{[3]} = [u_{M+1}^{[2]} + u_1^{[3]}, u_{M+2}^{[2]} + u_2^{[3]}, \dots, u_{2M}^{[2]} + u_M^{[3]}]^T, \quad (2.12)$$

CHAPTER 2: THREE-USER MIMO BC WITH DELAYED CSIT

$$\mathbf{x}(3) = \mathbf{u}_2^{[3]} + \mathbf{u}_2^{[1]} = [u_{M+1}^{[3]} + u_{M+1}^{[1]}, u_{M+2}^{[3]} + u_{M+2}^{[1]}, \dots, u_{2M}^{[3]} + u_{2M}^{[1]}]^T. \quad (2.13)$$

After the first time slot, each receiver obtains N noisy linear equations in terms of $\mathbf{u}_1^{[1]}$ and $\mathbf{u}_1^{[2]}$ over its N antennas. Consider all N equations available at RX₁ together with $M - N$ of the equations available at RX₂ (note that $M - N \leq N$):

$$\text{RX}_1 : \quad y_n^{[1]}(1) = (\mathbf{h}_n^{[1]}(1))^T \mathbf{u}_1^{[1]} + (\mathbf{h}_n^{[1]}(1))^T \mathbf{u}_1^{[2]} + z_n^{[1]}(1), \quad 1 \leq n \leq N, \quad (2.14)$$

$$\text{RX}_2 : \quad y_n^{[2]}(1) = (\mathbf{h}_n^{[2]}(1))^T \mathbf{u}_1^{[1]} + (\mathbf{h}_n^{[2]}(1))^T \mathbf{u}_1^{[2]} + z_n^{[2]}(1), \quad 1 \leq n \leq M - N, \quad (2.15)$$

where $\mathbf{h}_n^{[j]}(t)$ denotes the n 'th column of $(\mathbf{H}^{[j]}(t))^T$. If we somehow deliver $\{(\mathbf{h}_n^{[1]}(1))^T \mathbf{u}_1^{[2]}\}_{n=1}^N$ to both RX₁ and RX₂, then RX₁ can obtain $(\mathbf{h}_n^{[1]}(1))^T \mathbf{u}_1^{[1]} + z_n^{[1]}(1) = y_n^{[1]}(1) - (\mathbf{h}_n^{[1]}(1))^T \mathbf{u}_1^{[2]}$, $1 \leq n \leq N$, which are N *noisy* linearly independent equations in terms of its own information symbols. Also, RX₂ can use $\{(\mathbf{h}_n^{[1]}(1))^T \mathbf{u}_1^{[2]}\}_{n=1}^N$ as N linearly independent equations in terms its own information symbols (the elements of $\mathbf{u}_1^{[2]}$). The linear independence follows from the fact that the elements of $\mathbf{H}^{[j]}(t)$ are i.i.d., and hence, it is full rank almost surely. Since $N < M$, the rows of $\mathbf{H}^{[j]}(t)$ are linearly independent almost surely.

Remark 2. *Since the noise variance in each linear equation is bounded (it does not scale with P), as far as DoF is concerned, the noise terms can be neglected. Therefore, in our DoF analysis, we ignore the whole (bounded) noise at receivers.*

Similarly, if we deliver $\{(\mathbf{h}_n^{[2]}(1))^T \mathbf{u}_1^{[1]}\}_{n=1}^{M-N}$ to both RX₁ and RX₂, each of them can obtain $M - N$ linearly independent equations in terms of its own information symbols. Thus, we consider the set

$$\{u_n^{[1,2]}\}_{n=1}^M \triangleq \{(\mathbf{h}_n^{[1]}(1))^T \mathbf{u}_1^{[2]}\}_{n=1}^N \cup \{(\mathbf{h}_n^{[2]}(1))^T \mathbf{u}_1^{[1]}\}_{n=1}^{M-N} \quad (2.16)$$

as a set of M (1,2)-symbols. Note that each of RX₁ and RX₂ after delivering these M order-2 symbols will obtain M linearly independent equations in terms of its own information symbols. Similar order-2 symbols are defined for the receiver pairs (RX₂, RX₃) and (RX₁, RX₃) after the second and third time slots, respectively. Therefore, $K_2 = 3M$ order-2 symbols are generated after this phase. We note that according to delayed CSIT assumption, the transmitter has access to all the generated order-2 symbols by the end of

CHAPTER 2: THREE-USER MIMO BC WITH DELAYED CSIT

this phase. It only remains to deliver these order-2 symbols to their respective pairs of receivers. This will be accomplished during phases 2 and 3.

Phase 1 ($2N < M \leq 3N$): In this case, consider two different transmission schemes as follows:

- *Scheme 2-1*:

Similar to Scheme 1, $3M$ linear combinations of $6M$ information symbols are transmitted in 3 time slots. Now, after the first time slot, all the N equations available at RX_1 and all the N equations available at RX_2 are considered. Ignoring the noise, we have

$$\text{RX}_1 : \quad y_n^{[1]}(1) = (\mathbf{h}_n^{[1]}(1))^T \mathbf{u}_1^{[1]} + (\mathbf{h}_n^{[1]}(1))^T \mathbf{u}_1^{[2]}, \quad 1 \leq n \leq N, \quad (2.17)$$

$$\text{RX}_2 : \quad y_n^{[2]}(1) = (\mathbf{h}_n^{[2]}(1))^T \mathbf{u}_1^{[1]} + (\mathbf{h}_n^{[2]}(1))^T \mathbf{u}_1^{[2]}, \quad 1 \leq n \leq N. \quad (2.18)$$

Using the same arguments as in Scheme 1, the set

$$\{u_n^{[1,2]}\}_{n=1}^{2N} \triangleq \{(\mathbf{h}_n^{[1]}(1))^T \mathbf{u}_1^{[2]}\}_{n=1}^N \cup \{(\mathbf{h}_n^{[2]}(1))^T \mathbf{u}_1^{[1]}\}_{n=1}^N \quad (2.19)$$

is considered as a set of $2N$ (1, 2)-symbols. However, since $2N < M$, each of RX_1 and RX_2 after delivering $\{u_n^{[1,2]}\}_{n=1}^{2N}$ still needs $M - 2N$ extra (linearly independent) equations in terms of its own information symbols in order to be able to resolve all its M information symbols.

Note that after the first time slot, RX_3 also obtains N linear equations in terms of information symbols of both RX_1 and RX_2 almost surely. Consider $M - 2N$ of these equations ignoring the noise (note that $M - 2N \leq N$):

$$\text{RX}_3 : \quad y_n^{[3]}(1) = (\mathbf{h}_n^{[3]}(1))^T \mathbf{u}_1^{[1]} + (\mathbf{h}_n^{[3]}(1))^T \mathbf{u}_1^{[2]}, \quad 1 \leq n \leq M - 2N. \quad (2.20)$$

If we somehow deliver $\{(\mathbf{h}_n^{[3]}(1))^T \mathbf{u}_1^{[1]}\}_{n=1}^{M-2N}$ and $\{(\mathbf{h}_n^{[3]}(1))^T \mathbf{u}_1^{[2]}\}_{n=1}^{M-2N}$ to RX_1 and RX_2 , respectively, then each of them is provided with $M - 2N$ extra equations in terms of its information symbols. It is easy to see that the M desired equations which will then be available at each of RX_1 and RX_2 are linearly independent, and hence, can be solved for their M information symbols. To this end, we will deliver $\{(\mathbf{h}_n^{[3]}(1))^T \mathbf{u}_1^{[1]}\}_{n=1}^{M-2N}$ to

CHAPTER 2: THREE-USER MIMO BC WITH DELAYED CSIT

both RX_1 and RX_3 . Then, RX_3 can obtain $\{(\mathbf{h}_n^{[3]}(1))^T \mathbf{u}_1^{[2]}\}_{n=1}^{M-2N}$ using $(\mathbf{h}_n^{[3]}(1))^T \mathbf{u}_1^{[2]} = \mathbf{y}_n^{[3]}(1) - (\mathbf{h}_n^{[3]}(1))^T \mathbf{u}_1^{[1]}$. Hence, $(\mathbf{h}_n^{[3]}(1))^T \mathbf{u}_1^{[2]}$, $1 \leq n \leq M - 2N$, will indeed be new symbols which are available at RX_3 and are intended to be delivered to RX_2 . Now, we use the following notation:

Notation 1. A symbol (piece of information) which is available at RX_j and the transmitter, and is desired by RX_i , $i \neq j$, is denoted by $u^{[i;j]}$.

Therefore, $\{(\mathbf{h}_n^{[3]}(1))^T \mathbf{u}_1^{[1]}\}_{n=1}^{M-2N}$ is a set of $M-2N$ (1, 3)-symbols while $\{(\mathbf{h}_n^{[3]}(1))^T \mathbf{u}_1^{[2]}\}_{n=1}^{M-2N}$ is a set of $M - 2N$ side information symbols denoted by $\{u_n^{[2;3]}\}_{n=1}^{M-2N}$. Note that all these symbols are available at the transmitter using delayed CSIT. Proceeding in the same manner, we obtain $2N$ (2, 3)-symbols, $M - 2N$ (1, 2)-symbols, and $M - 2N$ symbols $\{u_n^{[3;1]}\}_{n=1}^{M-2N}$ (resp. $2N$ (1, 3)-symbols, $M - 2N$ (2, 3)-symbols, and $M - 2N$ symbols $\{u_n^{[1;2]}\}_{n=1}^{M-2N}$) after the second (resp. third) time slot. To summarize, a total of $(M - 2N) + 2N = M$ order-2 symbols for each pair of receivers are generated together with $\{u_n^{[2;3]}\}_{n=1}^{M-2N}$, $\{u_n^{[3;1]}\}_{n=1}^{M-2N}$, and $\{u_n^{[1;2]}\}_{n=1}^{M-2N}$.

The order-2 symbols are ready to be fed to phase 2. For the side information symbols, we note that for any $\{i, j\} \subset \{1, 2, 3\}$, if we have side information symbols of both types $u^{[i;j]}$ and $u^{[j;i]}$, then the following equation is an order-2 (i, j) -symbol:

$$u^{[i,j]} \triangleq u^{[i;j]} + u^{[j;i]}. \quad (2.21)$$

Indeed, if we deliver $u^{[i,j]}$ to both RX_i and RX_j , then RX_i can obtain $u^{[i;j]}$ by removing $u^{[j;i]}$ from $u^{[i,j]}$. RX_j can similarly obtain $u^{[j;i]}$.

Since we only have side information symbols of types $u^{[2;3]}$, $u^{[3;1]}$, and $u^{[1;2]}$, we simply repeat phase 1 with another $6M$ fresh information symbols (vectors $\mathbf{u}_1^{[j]}$ and $\mathbf{u}_2^{[j]}$, $1 \leq j \leq 3$). However, we now interchange the roles of receivers in constructing the side information symbols. Specifically, after the first time slot, $\{(\mathbf{h}_n^{[3]}(1))^T \mathbf{u}_1^{[2]}\}_{n=1}^{M-2N}$ serve as $M - 2N$ (2, 3)-symbols and $\{(\mathbf{h}_n^{[3]}(1))^T \mathbf{u}_1^{[1]}\}_{n=1}^{M-2N}$ serve as the side information available at RX_3 about RX_1 , denoted by $\{u_n^{[1;3]}\}_{n=1}^{M-2N}$. The side information symbols $\{u_n^{[2;1]}\}_{n=1}^{M-2N}$ and $\{u_n^{[3;2]}\}_{n=1}^{M-2N}$ are similarly generated after the second and third time slots, respectively. Therefore, using (2.21), the following $3 \times (M - 2N)$ order-2 symbols can be defined:

$$u_n^{[1,2]} \triangleq u_n^{[1;2]} + u_n^{[2;1]}, \quad 1 \leq n \leq M - 2N, \quad (2.22)$$

CHAPTER 2: THREE-USER MIMO BC WITH DELAYED CSIT

$$u_n^{[2;3]} \triangleq u_n^{[2;3]} + u_n^{[3;2]}, \quad 1 \leq n \leq M - 2N, \quad (2.23)$$

$$u_n^{[3;1]} \triangleq u_n^{[3;1]} + u_n^{[1;3]}, \quad 1 \leq n \leq M - 2N. \quad (2.24)$$

In summary, we transmit $K_1 = 2 \times 6M = 12M$ fresh information symbols in $T_1 = 2 \times 3 = 6$ time slots during two rounds of phase 1, and generate a total of $K_2 = 2 \times 3M + 3 \times (M - 2N) = 3(3M - 2N)$ order-2 symbols. We also note that all the order-2 symbols generated by the end of this phase are available at the transmitter by delayed CSIT assumption.

- *Scheme 2-2:*

It takes $T_1 = 6$ time slots to transmit $K_1 = 6M$ fresh information symbols, $2M$ information symbols per receiver. In each time slot, the transmitter transmits M fresh information symbols of *one* of the receivers over its M antennas. The first two time slots are dedicated to RX_1 . After the first time slot, RX_1 , obtaining N linearly independent equations over its N antennas, needs $M - N$ extra equations to resolve all its M information symbols. At the same time, each of RX_2 and RX_3 has obtained N linearly independent equations in terms of information symbols of RX_1 . Hence, all N equations available at RX_2 and $M - 2N$ of equations available at RX_3 are considered as $\{u_n^{[1;2]}\}_{n=1}^N$ and $\{u_n^{[1;3]}\}_{n=1}^{M-2N}$, respectively ($M - 2N \leq N$). If we deliver all these $M - N$ side information symbols to RX_1 , then it will be able to decode all its M information symbols.

In the second time slot, the transmitter transmits another M information symbols of RX_1 over its M antennas. In the same way, but interchanging the roles of RX_2 and RX_3 , we consider $M - 2N$ side information symbols of type $u^{[1;2]}$ at RX_2 together with N side information symbols of type $u^{[1;3]}$ at RX_3 . Therefore, after the first two time slots, two sets of $M - 2N + N = M - N$ side information symbols $\{u_n^{[1;2]}\}_{n=1}^{M-N}$ and $\{u_n^{[1;3]}\}_{n=1}^{M-N}$ are generated at RX_2 and RX_3 , respectively.

Analogously, the next two time slots are dedicated to transmission of $2M$ information symbols for RX_2 and generation of $\{u_n^{[2;1]}\}_{n=1}^{M-N}$ and $\{u_n^{[2;3]}\}_{n=1}^{M-N}$, and the last two time slots are dedicated to transmission of $2M$ information symbols for RX_3 and generation of $\{u_n^{[3;1]}\}_{n=1}^{M-N}$ and $\{u_n^{[3;2]}\}_{n=1}^{M-N}$. Then, using (2.22) to (2.24), $K_2 = 3(M - N)$ order-2

CHAPTER 2: THREE-USER MIMO BC WITH DELAYED CSIT

symbols $\{u_n^{[1,2]}\}_{n=1}^{M-N}$, $\{u_n^{[2,3]}\}_{n=1}^{M-N}$, and $\{u_n^{[3,1]}\}_{n=1}^{M-N}$ are generated, which will all be available at the transmitter by the end of this phase using delayed CSIT.

Phase 2: In each time slot, the transmitter transmits M' order-2 symbols intended for a *specific* pair of receivers over M' of its antennas, where

$$M' \triangleq \min(M, 2N). \quad (2.25)$$

Therefore, this phase takes T_2 time slots to transmit all K_2 order-2 symbols, where

$$T_2 = \frac{K_2}{M'}. \quad (2.26)$$

Assume that the first $T_2/3$ time slots are dedicated to transmission of (1, 2)-symbols. After each of these time slots, each of RX_1 and RX_2 obtains N linearly independent equations in terms of the transmitted (1, 2)-symbols, and so, needs $M' - N$ extra equations to resolve all order-2 symbols transmitted in this time slot. Concurrently, RX_3 also obtains N equations in terms of these order-2 symbols. Since $M' - N \leq N$, $M' - N$ of equations available at RX_3 can serve as the $M' - N$ extra equations required by both RX_1 and RX_2 . Now, we use the following notation:

Notation 2. A symbol (piece of information) which is available at RX_k and the transmitter, and is desired by both RX_i and RX_j , $i \neq j \neq k$, is denoted by $u^{[i,j;k]}$.

Hence, $\{u_n^{[1,2;3]}\}_{n=1}^{(M'-N)T_2/3}$ denotes the set of $(M' - N)T_2/3$ equations available at RX_3 and required by both RX_1 and RX_2 after the first $T_2/3$ time slots. Similarly, assuming that the second (resp. last) $T_2/3$ time slots are dedicated to transmission of (2, 3)-symbols (resp. (1, 3)-symbols), after these time slots, RX_1 (resp. RX_2) will obtain the set $\{u_n^{[2,3;1]}\}_{n=1}^{(M'-N)T_2/3}$ (resp. $\{u_n^{[3,1;2]}\}_{n=1}^{(M'-N)T_2/3}$) of $(M' - N)T_2/3$ equations required by both RX_2 and RX_3 (resp. RX_1 and RX_3).

Now, consider three symbols $u^{[2,3;1]}$, $u^{[3,1;2]}$, and $u^{[1,2;3]}$. Note that each receiver has exactly one of these three symbols and needs the other two. Hence, if we deliver *two* random linear combinations of these three symbols to all receivers, then RX_1 can remove $u^{[2,3;1]}$ from these two equations, and thereby, solve the two equations in terms of two

CHAPTER 2: THREE-USER MIMO BC WITH DELAYED CSIT

unknowns $u^{[1,2;3]}$ and $u^{[3,1;2]}$. RX_2 (resp. RX_3) can also perform a similar operation to obtain $u^{[1,2;3]}$ and $u^{[2,3;1]}$ (resp. $u^{[3,1;2]}$ and $u^{[2,3;1]}$). Therefore, defining K_3 as

$$K_3 \triangleq 2 \times \frac{(M' - N)T_2}{3} = \frac{2(M' - N)K_2}{3M'}, \quad (2.27)$$

K_3 random linear combinations are constructed as mentioned above and can be interpreted as order-3 symbols for phase 3.

Phase 3: The transmitter takes K_3 order-3 symbols and transmits N symbols in each time slot using N of its antennas (note $N < M$). Thus, this phase takes T_3 time slots, where

$$T_3 = \frac{K_3}{N} = \frac{2(M' - N)K_2}{3M'N}. \quad (2.28)$$

Using (2.26) and (2.28), we have

$$T_2 + T_3 = \frac{(2M' + N)K_2}{3M'N}. \quad (2.29)$$

Since each receiver is equipped with N antennas, it obtains N linearly independent equations in terms of N order-3 symbols almost surely, and hence, can resolve all order-3 symbols.

Finally, the achievable DoF of each proposed scheme can be found using

$$\underline{\text{DoF}}^{\text{BC}}(M, N, N, N) = \frac{K_1}{T_1 + T_2 + T_3}. \quad (2.30)$$

Using (2.29) and (2.30), the achievable DoF of the proposed schemes are found and summarized in Table 2.1. We note that for $N < M \leq 2N$, the achievable DoF is equal to the upper bound of (2.8), and thus, characterizes the channel DoF for this range of M and N . Also, the overall achievable DoF for $2N < M \leq 3N$ is equal to the maximum of those of the schemes 2-1 and 2-2:

$$\underline{\text{DoF}}^{\text{BC}}(M, N, N, N) = \max \left\{ \frac{12MN}{5M + 7N}, \frac{24MN}{15M + 2N} \right\}. \quad (2.31)$$

This last observation completes the proof. \square

CHAPTER 2: THREE-USER MIMO BC WITH DELAYED CSIT

Table 2.1: Different parameters together with the achievable DoF of the proposed schemes for (M, N, N, N) BC with delayed CSIT

Range of M	Scheme	K_1	$T_1 + T_2 + T_3$	$\underline{\text{DoF}}^{\text{BC}}(M, N, N, N)$
$N < M \leq 2N$	1	$6M$	$3 + \frac{2M+N}{N}$	$\frac{3MN}{M+2N}$
$2N < M \leq 3N$	2-1	$12M$	$6 + \frac{5(3M-2N)}{2N}$	$\frac{24MN}{15M+2N}$
	2-2	$6M$	$6 + \frac{5(M-N)}{2N}$	$\frac{12MN}{5M+7N}$

To get more insight into the behavior of the DoF in (M, N, N, N) BC with delayed CSIT, we define *normalized* DoF as $\underline{\text{DoF}}_{\text{norm}}^{\text{BC}}(\frac{M}{N}) \triangleq \frac{1}{3N} \underline{\text{DoF}}^{\text{BC}}(M, N, N, N)$. Also, defining the transmit-receive antenna ratio as $\bar{m} \triangleq M/N$, we can express the achievable $\underline{\text{DoF}}_{\text{norm}}^{\text{BC-dCSIT}}(\bar{m})$ as follows:

$$\underline{\text{DoF}}_{\text{norm}}^{\text{BC-dCSIT}}(\bar{m}) = \begin{cases} \frac{\bar{m}}{3} & \bar{m} \leq 1 \\ \frac{\bar{m}}{\bar{m}+2} & 1 < \bar{m} \leq 2 \\ \frac{8\bar{m}}{15\bar{m}+2} & 2 < \bar{m} \leq 2.4 \\ \frac{4\bar{m}}{5\bar{m}+7} & 2.4 < \bar{m} \leq 3 \\ \frac{6}{11} & 3 < \bar{m} \end{cases}. \quad (2.32)$$

Figure 2.1 compares our achievable $\underline{\text{DoF}}_{\text{norm}}^{\text{BC-dCSIT}}(\bar{m})$ with the upper bound of (2.8). It also plots DoF of (M, N, N, N) BC with no CSIT and also with full CSIT for comparison [56, 59]:

$$\begin{aligned} \text{DoF}_{\text{norm}}^{\text{BC-nCSIT}}(\bar{m}) &= \begin{cases} \frac{\bar{m}}{3} & 0 < \bar{m} \leq 1 \\ \frac{1}{3} & 1 < \bar{m} \end{cases}, \\ \text{DoF}_{\text{norm}}^{\text{BC-fCSIT}}(\bar{m}) &= \begin{cases} \frac{\bar{m}}{3} & 0 < \bar{m} \leq 3 \\ 1 & 3 < \bar{m} \end{cases}. \end{aligned} \quad (2.33)$$

CHAPTER 2: THREE-USER MIMO BC WITH DELAYED CSIT

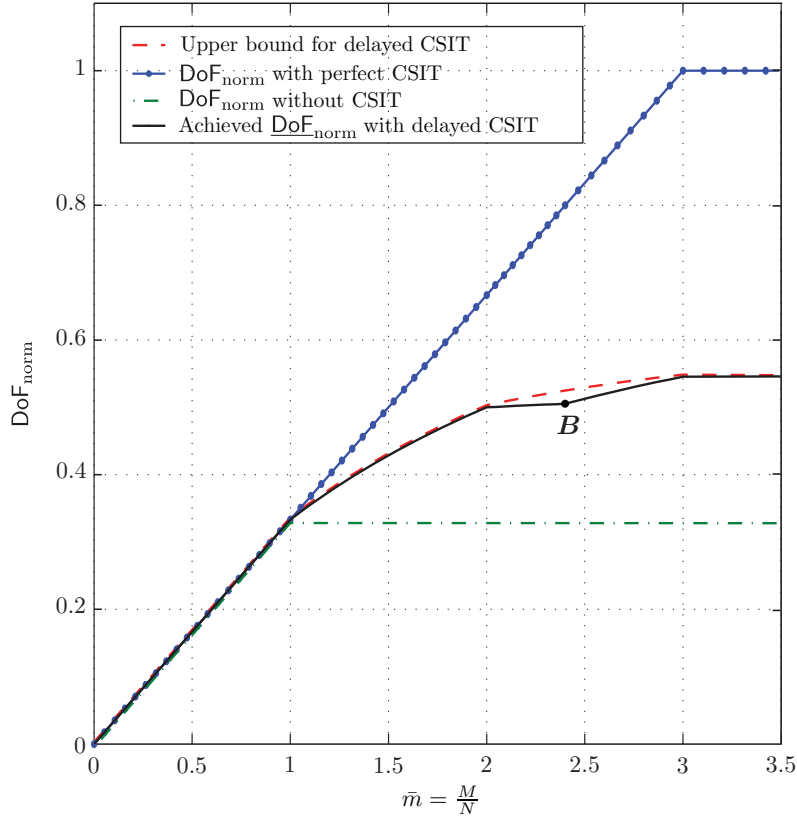

Figure 2.1: The normalized achievable DoF for (M, N, N, N) BC with delayed CSIT for $\bar{m} = \frac{M}{N} \leq 3.5$, and its comparison with the upper bound and also normalized channel DoFs with full CSIT and without CSIT.

The point $\bar{m} = 2.4$ (indicated as point B in the figure) is the breaking point below which Scheme 2-1 outperforms Scheme 2-2. Note also that the upper bound of (2.8) is equal to $\frac{2\bar{m}}{3\bar{m}+2}$ for $2 < \bar{m} < 3$, which is strictly greater than $\underline{\text{DoF}}_{\text{norm}}^{\text{BC-dCSIT}}(\bar{m})$ in this range of \bar{m} . The upper bound and $\underline{\text{DoF}}_{\text{norm}}^{\text{BC-dCSIT}}(\bar{m})$ merge together as \bar{m} approaches the borders of this interval.

2.3 (M, N_1, N_2, N_3) BC with Delayed CSIT

In this section, we consider the general (non-symmetric) case of (M, N_1, N_2, N_3) BC with delayed CSIT and arbitrary numbers of antennas at the receivers. We focus on the case

CHAPTER 2: THREE-USER MIMO BC WITH DELAYED CSIT

where

$$M \leq \max\{N_1, N_2, N_3, \min(N_1 + N_2, N_2 + N_3, N_3 + N_1)\}. \quad (2.34)$$

By developing interference alignment ideas to capture unequal numbers of receive antennas, we obtain achievable DoF regions for the non-symmetric BC. We obtain conditions on the number of antennas at different nodes under which our achievable DoF regions meet the outer bound of Proposition 1. As we will see, there will still remain some antenna configurations for which there exists a gap between the achievable and outer bound regions.

In the following, we assume without loss of generality that $N_1 \leq N_2 \leq N_3$, and thus, the antenna range of (2.34) is now equivalent to

$$M \leq \max(N_3, N_1 + N_2). \quad (2.35)$$

We first scrutinize the outer bound of Proposition 1 for this antenna range and determine its corner points. We then present our achievable schemes and obtain their tightness conditions.

Before proceeding with the details of the DoF region with delayed CSIT, we note that the DoF regions of the (M, N_1, N_2, N_3) BC without CSIT and also with full CSIT are known [56, 59] and given by

$$\mathcal{D}^{\text{BC-nCSIT}}(M, N_1, N_2, N_3) \triangleq \left\{ (d^{[1]}, d^{[2]}, d^{[3]}) \mid d^{[j]} \geq 0, \forall j, \sum_{j=1}^3 \frac{d^{[j]}}{\min(M, N_j)} \leq 1 \right\}, \quad (2.36)$$

$$\mathcal{D}^{\text{BC-fCSIT}}(M, N_1, N_2, N_3) \triangleq \left\{ (d^{[1]}, d^{[2]}, d^{[3]}) \mid \begin{aligned} &0 \leq d^{[j]} \leq \min(M, N_j), \quad \forall j, \\ &d^{[i]} + d^{[j]} \leq \min(M, N_i + N_j), \quad \forall i, j, i \neq j, \\ &\sum_{j=1}^3 d^{[j]} \leq \min(M, \sum_{j=1}^3 N_j) \end{aligned} \right\}. \quad (2.37)$$

We further partition the range $M \leq \max(N_3, N_1 + N_2)$ into 4 mutually exclusive ranges. In all ranges, we note that the corner points of the outer bound on the DoF axes are achievable even without CSIT. Hence, we call these points the “trivial” corner points and will not discuss their achievability in the following.

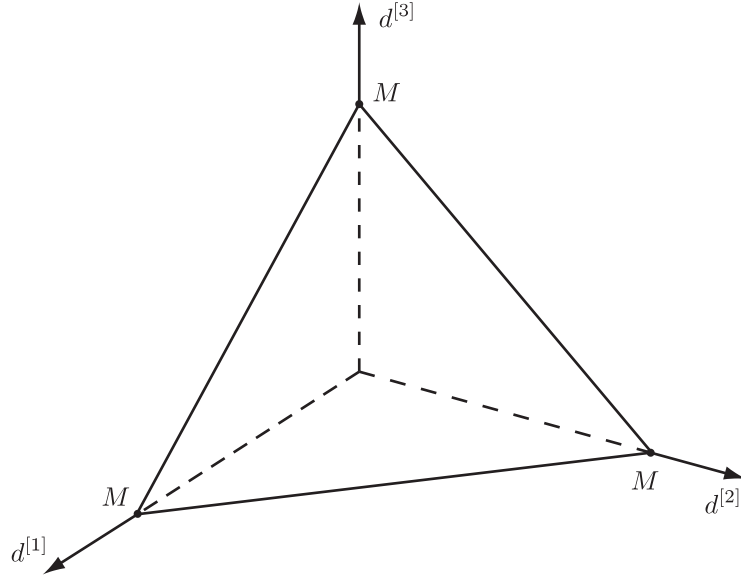
 Figure 2.2: Shape of the DoF region for $M \leq N_1$

1. $M \leq N_1$: In this range, the outer bound is characterized by the subregion of the first octant which is confined by the plane $d^{[1]}/M + d^{[2]}/M + d^{[3]}/M = 1$, as depicted in Fig. 2.2. It is easy to see that in this case,

$$\mathcal{D}^{\text{BC-nCSIT}} = \mathcal{D}^{\text{BC-dCSIT}} = \mathcal{D}_{\text{outer}}^{\text{BC-dCSIT}} = \mathcal{D}^{\text{BC-fCSIT}}. \quad (2.38)$$

2. $N_1 < M \leq N_2$: In this range, the outer bound is characterized by the subregion of the first octant which is confined by the plane $d^{[1]}/N_1 + d^{[2]}/M + d^{[3]}/M = 1$, as depicted in Fig. 2.3. Also, in this case we have

$$\mathcal{D}^{\text{BC-nCSIT}} = \mathcal{D}^{\text{BC-dCSIT}} = \mathcal{D}_{\text{outer}}^{\text{BC-dCSIT}} \subset \mathcal{D}^{\text{BC-fCSIT}}. \quad (2.39)$$

3. $N_2 < M \leq N_3$: We define

$$M' \triangleq \min(M, N_1 + N_2). \quad (2.40)$$

The outer bound is determined by the subregion of the first octant which is confined by the planes $d^{[1]}/N_1 + d^{[2]}/M' + d^{[3]}/M = 1$ and $d^{[1]}/M' + d^{[2]}/N_2 + d^{[3]}/M = 1$, as

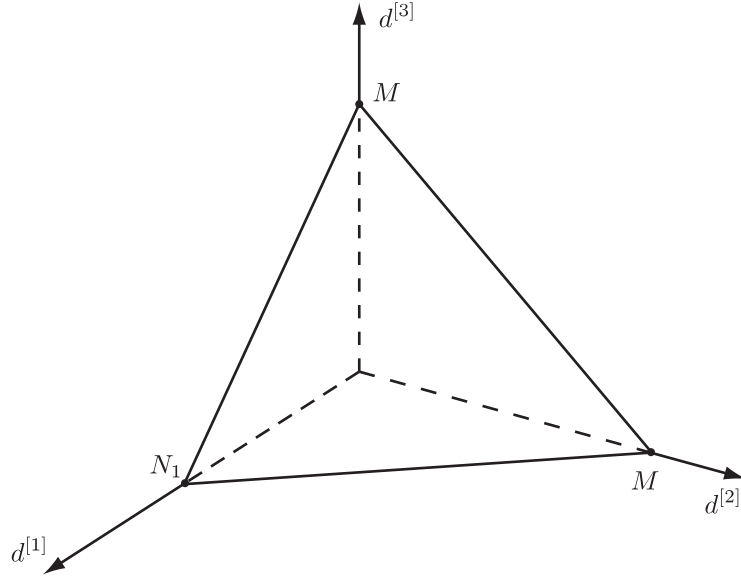
 Figure 2.3: Shape of the DoF region for $N_1 < M \leq N_2$

depicted in Fig. 2.4. In this case, the achievability of the non-trivial corner point

$$P_{12} = \left(\frac{M'N_1(M' - N_2)}{M'^2 - N_1N_2}, \frac{M'N_2(M' - N_1)}{M'^2 - N_1N_2}, 0 \right) \quad (2.41)$$

has been shown in [55] for a two-user MIMO BC with delayed CSIT and M antennas at the transmitter and N_1 and N_2 antennas at the receivers. One can also verify that in this range of antennas,

$$\mathcal{D}^{\text{BC-nCSIT}} \subset \mathcal{D}^{\text{BC-dCSIT}} = \mathcal{D}_{\text{outer}}^{\text{BC-dCSIT}} \subset \mathcal{D}^{\text{BC-fCSIT}}. \quad (2.42)$$

4. $N_3 < M \leq N_1 + N_2$: In this range, the outer bound is characterized by the subregion of the first octant which is confined by the planes

$$\mathcal{P}_1 : \quad \frac{d^{[1]}}{N_1} + \frac{d^{[2]}}{M} + \frac{d^{[3]}}{M} = 1, \quad (2.43)$$

$$\mathcal{P}_2 : \quad \frac{d^{[1]}}{M} + \frac{d^{[2]}}{N_2} + \frac{d^{[3]}}{M} = 1, \quad (2.44)$$

$$\mathcal{P}_3 : \quad \frac{d^{[1]}}{M} + \frac{d^{[2]}}{M} + \frac{d^{[3]}}{N_3} = 1, \quad (2.45)$$

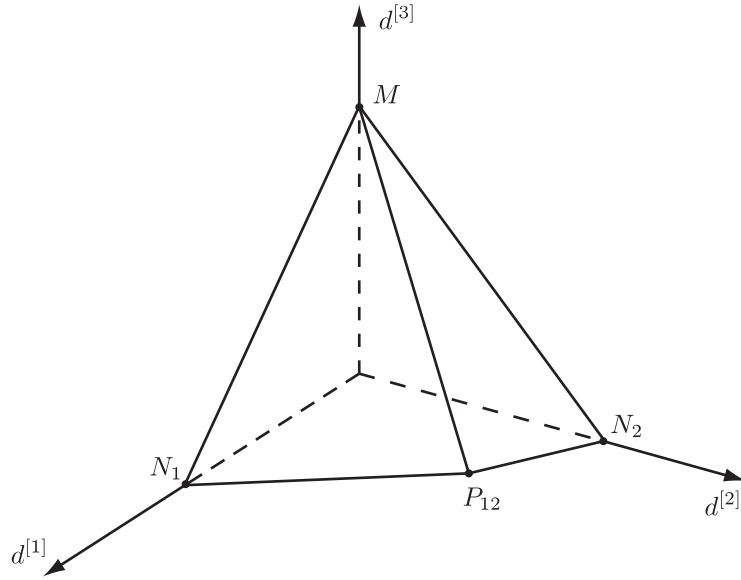
 Figure 2.4: Shape of the DoF region for $N_2 < M \leq N_3$

as depicted in Fig. 2.5. The corner points

$$P_{12} = \left(\frac{MN_1(M - N_2)}{M^2 - N_1N_2}, \frac{MN_2(M - N_1)}{M^2 - N_1N_2}, 0 \right), \quad (2.46)$$

$$P_{23} = \left(0, \frac{MN_2(M - N_3)}{M^2 - N_2N_3}, \frac{MN_3(M - N_2)}{M^2 - N_2N_3} \right), \quad (2.47)$$

$$P_{31} = \left(\frac{MN_1(M - N_3)}{M^2 - N_1N_3}, 0, \frac{MN_3(M - N_1)}{M^2 - N_1N_3} \right), \quad (2.48)$$

are achievable in two-user (M, N_1, N_2) BC, (M, N_2, N_3) BC, and (M, N_3, N_1) BC with delayed CSIT [55]. The corner point P is given by

$$P = \left(\frac{M(\bar{m}_2 - 1)(\bar{m}_3 - 1)}{\bar{m}_1\bar{m}_2\bar{m}_3 - \bar{m}_1 - \bar{m}_2 - \bar{m}_3 + 2}, \frac{M(\bar{m}_3 - 1)(\bar{m}_1 - 1)}{\bar{m}_1\bar{m}_2\bar{m}_3 - \bar{m}_1 - \bar{m}_2 - \bar{m}_3 + 2}, \frac{M(\bar{m}_1 - 1)(\bar{m}_2 - 1)}{\bar{m}_1\bar{m}_2\bar{m}_3 - \bar{m}_1 - \bar{m}_2 - \bar{m}_3 + 2} \right), \quad (2.49)$$

where $\bar{m}_i \triangleq M/N_i$, $1 \leq i \leq 3$. We note here that for the symmetric case $N_1 = N_2 = N_3 = N$, after trivial simplifications, we have $P = \left(\frac{N\bar{m}}{\bar{m}+2}, \frac{N\bar{m}}{\bar{m}+2}, \frac{N\bar{m}}{\bar{m}+2} \right)$. Also, this

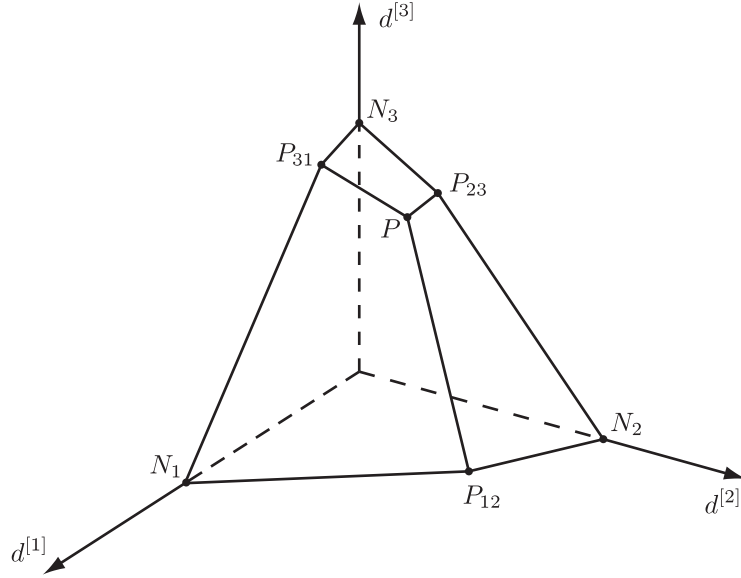

Figure 2.5: Shape of the DoF region outer bound for $N_3 < M \leq N_1 + N_2$

range of M will be equivalent to $N < M \leq 2N$. Recall that Scheme 1 proposed in Section 2.2 achieves the channel sum-DoF for $N < M \leq 2N$, which is $3N\bar{m}/(\bar{m} + 2)$ (cf. (2.32)). Therefore, point P for the symmetric case can be achieved by Scheme 1, and hence the outer bound is tight. In the rest of this section, we propose two different transmission schemes, namely *Scheme 3* and *Scheme 4* for $N_3 < M \leq N_1 + N_2$ and obtain the conditions on the number of antennas at different nodes under which the achievability of point P by our schemes is guaranteed.

- *Scheme 3*:

This scheme has 3 distinct phases as follows:

Phase 1 (Scheme 3): In this phase, $2M$ fresh information symbols per time slot are transmitted for a pair of receivers as in phase 1 of Scheme 1. In particular, T_{ij} time slots are spent for RX_i and RX_j , and order-2 symbols $\{u_n^{[i,j]}\}_{n=1}^{MT_{ij}}$ are generated, $(i, j) \in \{(1, 2), (2, 3), (3, 1)\}$. The parameters T_{ij} will be determined later.

CHAPTER 2: THREE-USER MIMO BC WITH DELAYED CSIT

Phase 2 (Scheme 3): The order-2 symbols generated in phase 1 are transmitted over the channel in this phase as follows: T_{ij} time slots are dedicated to transmission of $\{u_n^{[i,j]}\}_{n=1}^{MT_{ij}}$ for RX_i and RX_j , $(i, j) \in \{(1, 2), (2, 3), (3, 1)\}$. In each time slot, M order-2 symbols of type $u^{[i,j]}$ for a specific pair (i, j) are transmitted using the M transmit antennas. In the time slot dedicated to pair (i, j) , RX_i and RX_j respectively receive N_i and N_j linear combinations in terms of the transmitted order-2 symbols, and hence, require extra $M - N_i$ and $M - N_j$ linearly independent combinations to resolve all the M transmitted symbols. According to (2.34), we have $M - N_i \leq N_k$ and $M - N_j \leq N_k$, where $k \triangleq \{1, 2, 3\} \setminus \{i, j\}$. Now, if we deliver $M - N_i$ (resp. $M - N_j$) out of N_k equations available at RX_k to RX_i (resp. RX_j), it will be able to decode all the M transmitted order-2 symbols. Alternatively, it suffices to deliver $M - N_i$ (resp. $M - N_j$) random linear combinations of the N_k equations available at RX_k to RX_i (resp. RX_j). In summary, we have the following observations:

- (a) RX_1 needs $(T_{12} + T_{31})(M - N_1)$ random linear combinations of the $T_{12}N_3$ equations available at RX_3 and the $T_{31}N_2$ equations available at RX_2 .
- (b) RX_2 needs $(T_{12} + T_{23})(M - N_2)$ random linear combinations of the $T_{12}N_3$ equations available at RX_3 and the $T_{23}N_1$ equations available at RX_1 .
- (c) RX_3 needs $(T_{23} + T_{31})(M - N_3)$ random linear combinations of the $T_{23}N_1$ equations available at RX_1 and the $T_{31}N_2$ equations available at RX_2 .

The aforementioned linearly independent combinations will be delivered to each receiver in phase 3.

Phase 3 (Scheme 3): This phase takes T time slots. In each time slot, M random linear combinations of the $T_{23}N_1$, $T_{31}N_2$, and $T_{12}N_3$ equations (quantities or symbols) respectively available at RX_1 , RX_2 , and RX_3 are transmitted over the M transmit antennas. Hence, in each time slot, RX_i , $1 \leq i \leq 3$, obtains N_i linear combinations of its desired symbols out of the whole $T_{23}N_1 + T_{31}N_2 + T_{12}N_3$ symbols. Note that since $N_i < M$, $1 \leq i \leq 3$, these N_i linear combinations are independent almost surely. According to observations (a) to (c), T should satisfy the following inequalities simultaneously:

$$TN_1 \geq (T_{12} + T_{31})(M - N_1), \quad (2.50)$$

CHAPTER 2: THREE-USER MIMO BC WITH DELAYED CSIT

$$TN_2 \geq (T_{12} + T_{23})(M - N_2), \quad (2.51)$$

$$TN_3 \geq (T_{23} + T_{31})(M - N_3). \quad (2.52)$$

We indeed choose T to be

$$T \triangleq \max \left\{ \frac{(T_{12} + T_{31})(M - N_1)}{N_1}, \frac{(T_{12} + T_{23})(M - N_2)}{N_2}, \frac{(T_{23} + T_{31})(M - N_3)}{N_3} \right\}, \quad (2.53)$$

or equivalently,

$$T \triangleq \max \left\{ (T_{12} + T_{31})(\bar{m}_1 - 1), (T_{12} + T_{23})(\bar{m}_2 - 1), (T_{23} + T_{31})(\bar{m}_3 - 1) \right\}. \quad (2.54)$$

If T_{12} , T_{23} , and T_{31} are scaled by the same factor, the achievable DoF will not change. Hence, by an appropriate scaling of T_{12} , T_{23} , and T_{31} , we can always ensure that T is an integer.

Since $2(T_{12} + T_{23} + T_{31}) + T$ time slots have been spent to deliver $M(T_{12} + T_{31})$ information symbols to RX_1 , $M(T_{12} + T_{23})$ information symbols to RX_2 , and $M(T_{23} + T_{31})$ information symbols to RX_3 , this transmission scheme achieves the following DoF tuple:

$$P' \triangleq \left(\frac{M(T_{12} + T_{31})}{2(T_{12} + T_{23} + T_{31}) + T}, \frac{M(T_{12} + T_{23})}{2(T_{12} + T_{23} + T_{31}) + T}, \frac{M(T_{23} + T_{31})}{2(T_{12} + T_{23} + T_{31}) + T} \right). \quad (2.55)$$

Any choice of $(T_{12}, T_{23}, T_{31}) \in (\mathbb{R}^{\geq 0})^3$ yields an achievable DoF tuple P' given by (2.55) with T given by (2.54). Now, we examine the achievable DoF tuple P' and derive the necessary and sufficient conditions to have $P' = P$. Let us define

$$T_1 \triangleq T_{31} + T_{12}, \quad (2.56)$$

$$T_2 \triangleq T_{12} + T_{23}, \quad (2.57)$$

$$T_3 \triangleq T_{23} + T_{31}. \quad (2.58)$$

Then, we can rewrite (2.54) and (2.55) as

$$T = \max \left\{ T_1(\bar{m}_1 - 1), T_2(\bar{m}_2 - 1), T_3(\bar{m}_3 - 1) \right\}, \quad (2.59)$$

$$P' = \left(\frac{MT_1}{T_1 + T_2 + T_3 + T}, \frac{MT_2}{T_1 + T_2 + T_3 + T}, \frac{MT_3}{T_1 + T_2 + T_3 + T} \right). \quad (2.60)$$

CHAPTER 2: THREE-USER MIMO BC WITH DELAYED CSIT

Inserting the coordinates of P' into the planes \mathcal{P}_1 , \mathcal{P}_2 , and \mathcal{P}_3 , i.e., (2.43) to (2.45), we get

$$\mathcal{P}_1 : \quad \frac{\bar{m}_1 T_1 + T_2 + T_3}{T_1 + T_2 + T_3 + T} = \frac{T_1 + T_2 + T_3 + T_1(\bar{m}_1 - 1)}{T_1 + T_2 + T_3 + T} \leq 1, \quad (2.61)$$

$$\mathcal{P}_2 : \quad \frac{T_1 + \bar{m}_2 T_2 + T_3}{T_1 + T_2 + T_3 + T} = \frac{T_1 + T_2 + T_3 + T_2(\bar{m}_2 - 1)}{T_1 + T_2 + T_3 + T} \leq 1, \quad (2.62)$$

$$\mathcal{P}_3 : \quad \frac{T_1 + T_2 + \bar{m}_3 T_3}{T_1 + T_2 + T_3 + T} = \frac{T_1 + T_2 + T_3 + T_3(\bar{m}_3 - 1)}{T_1 + T_2 + T_3 + T} \leq 1, \quad (2.63)$$

where the inequalities follow from (2.59). Also, by (2.59), at least one of inequalities (2.61) to (2.63) holds with equality, and thus, point P' always lies on the outer bound. Therefore, we have $P' = P$ if and only if the following set of equations has a solution in $(\mathbb{R}^{\geq 0})^3$:

$$(T_{12} + T_{31})(\bar{m}_1 - 1) = (T_{12} + T_{23})(\bar{m}_2 - 1) = (T_{23} + T_{31})(\bar{m}_3 - 1). \quad (2.64)$$

The above set of equations determines a line in \mathbb{R}^3 which passes through the origin and can also be expressed as:

$$\frac{T_{12}}{\tilde{m}_2 \tilde{m}_3 + \tilde{m}_3 \tilde{m}_1 - \tilde{m}_1 \tilde{m}_2} = \frac{T_{23}}{\tilde{m}_3 \tilde{m}_1 + \tilde{m}_1 \tilde{m}_2 - \tilde{m}_2 \tilde{m}_3} = \frac{T_{31}}{\tilde{m}_1 \tilde{m}_2 + \tilde{m}_2 \tilde{m}_3 - \tilde{m}_3 \tilde{m}_1}, \quad (2.65)$$

where $\tilde{m}_i \triangleq \bar{m}_i - 1$, $1 \leq i \leq 3$. Hence, (2.64) has a solution (infinitely many solutions) in $(\mathbb{R}^{\geq 0})^3$ if and only if the above line passes through the first octant in \mathbb{R}^3 , i.e., if all the denominators in (2.65) have the same sign. Equivalently, the inequalities

$$(\tilde{m}_2 \tilde{m}_3 + \tilde{m}_3 \tilde{m}_1 - \tilde{m}_1 \tilde{m}_2)(\tilde{m}_3 \tilde{m}_1 + \tilde{m}_1 \tilde{m}_2 - \tilde{m}_2 \tilde{m}_3) \geq 0, \quad (2.66)$$

$$(\tilde{m}_3 \tilde{m}_1 + \tilde{m}_1 \tilde{m}_2 - \tilde{m}_2 \tilde{m}_3)(\tilde{m}_1 \tilde{m}_2 + \tilde{m}_2 \tilde{m}_3 - \tilde{m}_3 \tilde{m}_1) \geq 0, \quad (2.67)$$

$$(\tilde{m}_2 \tilde{m}_3 + \tilde{m}_3 \tilde{m}_1 - \tilde{m}_1 \tilde{m}_2)(\tilde{m}_1 \tilde{m}_2 + \tilde{m}_2 \tilde{m}_3 - \tilde{m}_3 \tilde{m}_1) \geq 0 \quad (2.68)$$

must hold, which can be simplified to the following inequalities by some manipulations:

$$|\tilde{m}_1 \tilde{m}_2 - \tilde{m}_2 \tilde{m}_3| \leq \tilde{m}_3 \tilde{m}_1, \quad (2.69)$$

$$|\tilde{m}_2 \tilde{m}_3 - \tilde{m}_3 \tilde{m}_1| \leq \tilde{m}_1 \tilde{m}_2, \quad (2.70)$$

$$|\tilde{m}_3 \tilde{m}_1 - \tilde{m}_1 \tilde{m}_2| \leq \tilde{m}_2 \tilde{m}_3. \quad (2.71)$$

CHAPTER 2: THREE-USER MIMO BC WITH DELAYED CSIT

Since $N_1 \leq N_2 \leq N_3 \leq M$, we have $0 \leq \tilde{m}_3 \leq \tilde{m}_2 \leq \tilde{m}_1$, and thus, $\tilde{m}_2\tilde{m}_3 \leq \tilde{m}_1\tilde{m}_2$, $\tilde{m}_2\tilde{m}_3 \leq \tilde{m}_3\tilde{m}_1$, and $\tilde{m}_3\tilde{m}_1 \leq \tilde{m}_1\tilde{m}_2$. Therefore, the above inequalities reduce to the pair of inequalities

$$\tilde{m}_1\tilde{m}_2 \leq \tilde{m}_2\tilde{m}_3 + \tilde{m}_3\tilde{m}_1, \quad (2.72)$$

$$\tilde{m}_3\tilde{m}_1 \leq \tilde{m}_1\tilde{m}_2 + \tilde{m}_2\tilde{m}_3. \quad (2.73)$$

Since $\tilde{m}_3 \leq \tilde{m}_2$, it is easy to see that inequality (2.73) holds for the whole range of $N_3 < M \leq N_1 + N_2$. Hence, one must only satisfy inequality (2.72), or equivalently,

$$\left(\frac{M}{N_1} - 1\right) \left(\frac{M}{N_2} - 1\right) \leq \left(\frac{M}{N_3} - 1\right) \left(\frac{M}{N_1} + \frac{M}{N_2} - 2\right). \quad (2.74)$$

It is observed that the inequality (2.74) does not necessarily hold for the whole range of $N_3 < M \leq N_1 + N_2$. We also note that for the symmetric case $N_1 = N_2 = N_3 = N$, (2.74) holds for the entire range of $N < M \leq 2N$.

Finally, let us characterize the achievable DoF region when (2.74) is not satisfied. In fact, we need to obtain T_{12} , T_{23} , and T_{31} such that their corresponding point P' yields the largest achievable region. We can easily verify from (2.55) that P' satisfies the following inequalities

$$d^{[1]} \leq d^{[2]} + d^{[3]}, \quad (2.75)$$

$$d^{[2]} \leq d^{[3]} + d^{[1]}, \quad (2.76)$$

$$d^{[3]} \leq d^{[1]} + d^{[2]}. \quad (2.77)$$

One can also show using (2.49) that the point P satisfies the first two inequalities for the whole range of $N_3 < M \leq N_1 + N_2$, and the third inequality if and only if the inequality (2.74) holds. Therefore, if (2.74) does not hold, the plane $d^{[3]} = d^{[1]} + d^{[2]}$ intersects the segment $P_{12}P$ in Fig. 2.5 at a point which is strictly between P_{12} and P . Let us denote this point by P_a .

The point P_a is indeed the intersection of the planes $d^{[1]}/N_1 + d^{[2]}/M + d^{[3]}/M = 1$, $d^{[1]}/M + d^{[2]}/N_1 + d^{[3]}/M = 1$, and $d^{[3]} = d^{[1]} + d^{[2]}$, which can be shown to be

$$P_a = \left(\frac{M\tilde{m}_2}{\tilde{m}_1\tilde{m}_2 + 2(\tilde{m}_1 + \tilde{m}_2)}, \frac{M\tilde{m}_1}{\tilde{m}_1\tilde{m}_2 + 2(\tilde{m}_1 + \tilde{m}_2)}, \frac{M(\tilde{m}_1 + \tilde{m}_2)}{\tilde{m}_1\tilde{m}_2 + 2(\tilde{m}_1 + \tilde{m}_2)} \right). \quad (2.78)$$

CHAPTER 2: THREE-USER MIMO BC WITH DELAYED CSIT

This point can be achieved by our scheme using $T_{12} = 0$ and $T_{23} = \frac{\tilde{m}_1}{\tilde{m}_2} T_{31}$ in (2.55). Therefore, the polyhedron characterized by the corner points P_a , P_{12} , P_{23} , P_{31} , $(N_1, 0, 0)$, $(0, N_2, 0)$, and $(0, 0, N_3)$ is achievable. The typical shape of this achievable region is depicted in Fig. 2.6. To show that this is the largest DoF region among all the DoF regions with corner point P' (if (2.74) does not hold), consider the difference between this region and the outer bound, i.e., the pyramid $PP_{31}P_{23}P_a$. It suffices to show that P' cannot lie inside this pyramid. To this end, we indeed show that the inequality (2.77), which is a necessary condition for the coordinates of the point P' , cannot be satisfied by any point inside the pyramid. Now, we have the following observations about the corner points of the pyramid:

- P : For this point, as already mentioned, we have $d^{[3]} > d^{[1]} + d^{[2]}$.
- P_{31} and P_{23} : Since $\tilde{m}_3 \leq \tilde{m}_2 \leq \tilde{m}_1$, one can easily verify using (2.47) and (2.48) that for these two points we have $d^{[3]} \geq d^{[1]} + d^{[2]}$.
- P_a : For this point, by definition, we have $d^{[3]} = d^{[1]} + d^{[2]}$.

Since any point inside the pyramid is a weighted summation of the corner points P , P_{31} , P_{23} , and P_a with positive weights, the above observations imply the desired conclusion.

In the following, we propose another transmission scheme and obtain the conditions under which it achieves the corner point P on the outer bound.

- *Scheme 4*:

This scheme has 2 distinct phases.

Phase 1 (Scheme 4): The first T_1 time slots are dedicated to transmission of information symbols for RX_1 , M fresh information symbols per time slot over the M transmit antennas. After each time slot, RX_1 receives N_1 linearly independent combinations of the M symbols, and thus, needs $M - N_1$ extra equations to resolve all the M symbols. On the other hand, RX_2 and RX_3 respectively receive N_2 and N_3 linear combinations in terms of the M information symbols of RX_1 . Consider the matrix $\mathbf{H}^{[i]}$ of size $N_i \times M$ of the channel

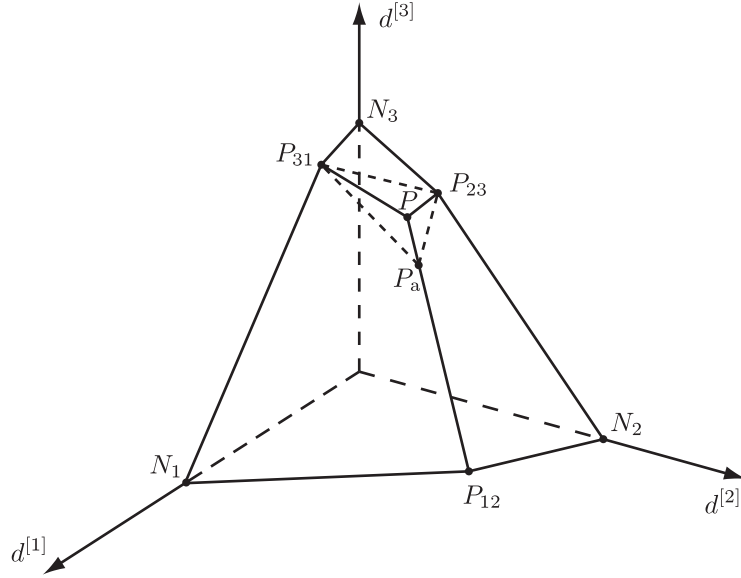

Figure 2.6: Shape of the achievable DoF region for $N_3 < M \leq N_1 + N_2$ using Scheme 3 when the condition (2.74) does *not* hold. The region with corner point P_a is achievable.

coefficients of RX_i , $1 \leq i \leq 3$, in a specific time slot. The time index has been omitted for ease of notations.

Denote the *row spaces* of $\mathbf{H}^{[1]}$, $\mathbf{H}^{[2]}$, and $\mathbf{H}^{[3]}$ by $\mathcal{H}^{[1]}$, $\mathcal{H}^{[2]}$, and $\mathcal{H}^{[3]}$, respectively. Also, denote by $\mathcal{H}^{[2]} \cap \mathcal{H}^{[3]}$ (resp. $\mathcal{H}^{[1]} \cap \mathcal{H}^{[2]} \cap \mathcal{H}^{[3]}$) the intersection of $\mathcal{H}^{[2]}$ and $\mathcal{H}^{[3]}$ (resp. $\mathcal{H}^{[1]}$, $\mathcal{H}^{[2]}$, and $\mathcal{H}^{[3]}$). Since $\mathbf{H}^{[1]}$, $\mathbf{H}^{[2]}$, and $\mathbf{H}^{[3]}$ are generated i.i.d. and $\max\{N_1, N_2, N_3\} \leq M$, their row spaces are respectively N_1 -dimensional, N_2 -dimensional, and N_3 -dimensional almost surely. Thus, since $\mathbf{H}^{[1]}$, $\mathbf{H}^{[2]}$, and $\mathbf{H}^{[3]}$ are generated independent of each other, from standard linear algebra we have

$$\dim(\mathcal{H}^{[2]} \cap \mathcal{H}^{[3]}) = (N_2 + N_3 - M)^+, \quad (2.79)$$

$$\dim(\mathcal{H}^{[1]} \cap \mathcal{H}^{[2]} \cap \mathcal{H}^{[3]}) = (N_1 + \dim(\mathcal{H}^{[2]} \cap \mathcal{H}^{[3]}) - M)^+ = ((N_2 + N_3 - M)^+ + N_1 - M)^+, \quad (2.80)$$

where $(x)^+ \triangleq \max(x, 0)$. We further assume that

$$M \leq \frac{1}{2}(N_1 + N_2 + N_3). \quad (2.81)$$

CHAPTER 2: THREE-USER MIMO BC WITH DELAYED CSIT

Then, since $M \leq N_2 + N_3$, one can show in view of (2.81) that

$$\dim(\mathcal{H}^{[2]} \cap \mathcal{H}^{[3]}) = N_2 + N_3 - M, \quad \text{almost surely,} \quad (2.82)$$

$$\dim(\mathcal{H}^{[1]} \cap \mathcal{H}^{[2]} \cap \mathcal{H}^{[3]}) = N_1 + N_2 + N_3 - 2M, \quad \text{almost surely.} \quad (2.83)$$

Denote by $\mathbf{H}^{[123]}$ the matrix of size $(N_2 + N_3 - M) \times M$ containing the basis vectors of $\mathcal{H}^{[2]} \cap \mathcal{H}^{[3]}$ as its rows, whose first $N_1 + N_2 + N_3 - 2M$ rows also constitute a basis for $\mathcal{H}^{[1]} \cap \mathcal{H}^{[2]} \cap \mathcal{H}^{[3]}$. Therefore, the last $(N_2 + N_3 - M) - (N_1 + N_2 + N_3 - 2M) = M - N_1$ rows of $\mathbf{H}^{[123]}$ are linearly independent of the rows of $\mathbf{H}^{[1]}$. Also, since all these $M - N_1$ row vectors lie in both $\mathcal{H}^{[2]}$ and $\mathcal{H}^{[3]}$, if any of them is used as the coefficient vector to linearly combine the M transmitted information symbols, the result is available at both RX_2 and RX_3 . Hence, $M - N_1$ linearly independent combinations can be formed which are all available at both RX_2 and RX_3 . These equations are linearly independent of the equations available at RX_1 , and thus, constitute the $M - N_1$ extra equations required by RX_1 . We denote each of them as a symbol of type $u^{[1;2,3]}$. Therefore, after T_1 time slots, $T_1(M - N_2)$ symbols of type $u^{[1;2,3]}$ are generated.

Similarly, the next T_2 and T_3 time slots are dedicated to transmission of information symbols of RX_2 and RX_3 and generation of $T_2(M - N_2)$ and $T_3(M - N_3)$ symbols of type $u^{[2;3,1]}$ and $u^{[3;1,2]}$, respectively. We emphasize that the same condition of (2.81) is also required in these T_2 and T_3 time slots. The generated symbols will be delivered to their corresponding receiver in phase 2.

Phase 2 (Scheme 4): This phase takes T time slots. In each time slot, M random linear combinations of all the $T_1(M - N_1) + T_2(M - N_2) + T_3(M - N_3)$ symbols generated in phase 1 are transmitted over the M transmit antennas. We note that RX_i , $1 \leq i \leq 3$, needs $T_i(M - N_i)$ out of these symbols, while having the rest of symbols. Hence, in each time slot, RX_i receives N_i linearly independent equations solely in terms of its desired symbols. Therefore, the following condition guarantees that each receiver obtains enough number of equations to resolve all its desired symbols:

$$T = \max \left\{ \frac{T_1(M - N_1)}{N_1}, \frac{T_2(M - N_2)}{N_2}, \frac{T_3(M - N_3)}{N_3} \right\}, \quad (2.84)$$

CHAPTER 2: THREE-USER MIMO BC WITH DELAYED CSIT

or equivalently,

$$T = \max \left\{ T_1(\bar{m}_1 - 1), T_2(\bar{m}_2 - 1), T_3(\bar{m}_3 - 1) \right\}. \quad (2.85)$$

The achieved DoF tuple is then given by

$$P' = \left(\frac{MT_1}{T_1 + T_2 + T_3 + T}, \frac{MT_2}{T_1 + T_2 + T_3 + T}, \frac{MT_3}{T_1 + T_2 + T_3 + T} \right). \quad (2.86)$$

Since the expressions for T and P' are the same as (2.59) and (2.60), in order for Scheme 4 to achieve the corner point P on the outer bound, the following set of equations should have a solution in $(\mathbb{R}^{\geq 0})^3$:

$$T_1(\bar{m}_1 - 1) = T_2(\bar{m}_2 - 1) = T_3(\bar{m}_3 - 1). \quad (2.87)$$

The above equation is a line which passes through the origin in \mathbb{R}^3 . Since $\bar{m}_i \geq 1$, $1 \leq i \leq 3$, it passes through the first octant, and thus, there are infinitely many solutions in $(\mathbb{R}^{\geq 0})^3$ for (2.87). Therefore, Scheme 4 achieves the corner point P if and only if the inequality (2.81) is satisfied.

In summary, let us define the following regions:

$$\mathcal{D}_1 \triangleq \left\{ (d^{[1]}, d^{[2]}, d^{[3]}) \mid d^{[j]} \geq 0, \forall j, \frac{d^{[1]}}{\min(M, N_1)} + \frac{d^{[2]}}{M} + \frac{d^{[3]}}{M} \leq 1 \right\}, \quad (2.88)$$

$$\mathcal{D}_2 \triangleq \left\{ (d^{[1]}, d^{[2]}, d^{[3]}) \mid d^{[j]} \geq 0, \forall j, \frac{d^{[1]}}{N_1} + \frac{d^{[2]}}{M} + \frac{d^{[3]}}{M} \leq 1, \frac{d^{[1]}}{M} + \frac{d^{[2]}}{N_2} + \frac{d^{[3]}}{M} \leq 1 \right\}, \quad (2.89)$$

$$\mathcal{D}_3 \triangleq \left\{ (d^{[1]}, d^{[2]}, d^{[3]}) \mid d^{[j]} \geq 0, \forall j, \frac{d^{[1]}}{N_1} + \frac{d^{[2]}}{M} + \frac{d^{[3]}}{M} \leq 1, \frac{d^{[1]}}{M} + \frac{d^{[2]}}{N_2} + \frac{d^{[3]}}{M} \leq 1, \frac{d^{[1]}}{M} + \frac{d^{[2]}}{M} + \frac{d^{[3]}}{N_3} \leq 1 \right\}. \quad (2.90)$$

Define the condition \mathcal{C}^* as

$$\mathcal{C}^* \triangleq M \leq \frac{1}{2}(N_1 + N_2 + N_3) \quad \text{or} \quad \left(\frac{M}{N_1} - 1 \right) \left(\frac{M}{N_2} - 1 \right) \leq \left(\frac{M}{N_3} - 1 \right) \left(\frac{M}{N_1} + \frac{M}{N_2} - 2 \right), \quad (2.91)$$

CHAPTER 2: THREE-USER MIMO BC WITH DELAYED CSIT

and also, define \mathcal{D}_4 as the region in the first octant which is confined by the plane passing through the points P_a , P_{23} , and P_{31} . Then, the results of this section are summarized in the following theorem:

Theorem 2. *In (M, N_1, N_2, N_3) BC with delayed CSIT and $N_1 \leq N_2 \leq N_3$ and $M \leq \max(N_3, N_1 + N_2)$, we have the following:*

- (i) *If $M \leq N_2$, $\mathcal{D}^{\text{BC-dCSIT}} = \mathcal{D}_1$,*
- (ii) *If $N_2 < M \leq N_3$, $\mathcal{D}^{\text{BC-dCSIT}} = \mathcal{D}_2$,*
- (iii) *If $N_3 < M \leq N_1 + N_2$ and condition \mathcal{C}^* is satisfied, $\mathcal{D}^{\text{BC-dCSIT}} = \mathcal{D}_3$.*
- (iv) *If $N_3 < M \leq N_1 + N_2$ and condition \mathcal{C}^* is not satisfied, $\mathcal{D}_3 \cap \mathcal{D}_4 \subseteq \mathcal{D}^{\text{BC-dCSIT}} \subseteq \mathcal{D}_3$.*

2.4 Conclusion

We studied the impact of delayed CSIT on the DoF of the 3-user Gaussian MIMO broadcast channel. We first considered the symmetric case with M antennas at the transmitter and N antennas at each receiver. By developing new multiphase transmission schemes, we obtained achievable sum-DoF for any pair of positive integers $M, N \in \mathbb{Z}^+$. Moreover, we showed that our achievable sum-DoF meets the upper bound for $M \leq 2N$ and $M \geq 3N$, and hence, characterizes the channel sum-DoF with delayed CSIT. For $2N < M < 3N$, we achieved DoF values close to the best known upper bound on the sum-DoF of this channel.

We then investigated the general MIMO case with arbitrary number of antennas at each node. We obtained achievable DoF regions for specific antenna configurations and obtained the subclass of antenna configuration sfor which our achievable DoF region is tight and characterizes the channel DoF region with delayed CSIT. Our results show that for a large subset of antenna configurations, the sum-DoF and DoF region of the three-user MIMO broadcast channel with delayed CSIT strictly lie between those with no CSIT and full CSIT.

Chapter 3

SISO Interference and X Channels with Delayed CSIT

In this chapter¹, we study SISO Gaussian interference and X channels with delayed CSIT. It is known that both channels have no more than one degree of freedom (DoF) without CSI at transmitters. We propose multi-phase transmission schemes that exploit the delayed CSIT to achieve DoF values greater than one, except for the two-user interference channel whose DoF is equal to one even with full CSIT. In contrast to the broadcast channel, in networks with distributed transmitters such as interference and X channels, there is a fundamental constraint in using the knowledge of past CSI at transmitters: Each transmitter has only access to its own information symbols. Indeed, a transmitter cannot obtain the whole past interference at a receiver when the interference is due to more than one interferer. This restriction turns out to be a performance limiting factor in terms of DoF of the system for networks with more than two users.

After presenting the system model in Section 3.1, we present and briefly discuss our main results of this chapter in Section 3.2. Then, we prove our results for interference and X channels in Sections 3.3 and 3.4. In specific, we first investigate the 3-user SISO interference channel with delayed CSIT and show that $36/31$ DoF is achievable in this channel. This is greater than the previously reported $9/8$ DoF in [35]. Then, we consider the K -user SISO

¹Part of the work in this chapter has been reported in [1,2]

CHAPTER 3: SISO IC AND X CHANNEL WITH DELAYED CSIT

interference channel for $K > 3$ with delayed CSIT, and propose a transmission scheme that achieves DoF values which are strictly increasing in K and approach the limiting value of $4/(6 \ln 2 - 1) \approx 1.2663$ as $K \rightarrow \infty$. Thereafter, we investigate the X channel with delayed CSIT in Section 3.4. We first consider the 2×3 SISO X channel as an example and show that this channel can achieve $9/7$ DoF under delayed CSIT assumption. By generalizing our transmission scheme to the $2 \times K$ SISO X channel with delayed CSIT, we achieve DoF values which are strictly increasing in K and approach the limiting value of $1/\ln 2 \approx 1.4427$ as $K \rightarrow \infty$. For $K \geq 3$, our achievable DoFs for the $2 \times K$ X channel are strictly greater than the achievable DoFs reported in [23] for the $K \times K$ X channel with delayed CSIT. Finally, in Section 3.5, we consider the effect of limited network connectivity in the form of so-called “ K -user r -cyclic interference channel” wherein each transmitter causes interference on a subset of $r - 1$ receivers which are neighbouring its paired receiver in a cyclic manner. We first show that DoF of this channel without any CSI at the transmitters is equal to K/r . We then focus on $r = 3$ and study the impact of delayed CSIT on DoF of this channel. We propose a transmission scheme that achieves DoF values greater than K/r for every $K \geq 3$. We conclude this chapter in Section 3.6.

3.1 System Model

A K -user interference channel (IC) with private messages is a set of K transmitters and K receivers, depicted in Fig. 3.1, where transmitter i (TX_i), $1 \leq i \leq K$, wishes to communicate a message $W^{[i]} \in \{1, 2, 3, \dots, 2^{\tau R^{[i]}}\}$ of rate $R^{[i]}$ to receiver i (RX_i) over a block of τ channel uses (or time slots). In time slot t , $t = 1, 2, \dots, \tau$, signal $x^{[i]}(t) \in \mathbb{C}$ is transmitted by TX_i , $1 \leq i \leq K$, and signal $y^{[j]}(t) \in \mathbb{C}$ is received by RX_j , $1 \leq j \leq K$, where

$$y^{[j]}(t) = \sum_{i=1}^K h^{[ji]}(t)x^{[i]}(t) + z^{[j]}(t), \quad (3.1)$$

and $h^{[ji]}(t) \in \mathbb{C}$ is the channel coefficient from TX_i to RX_j , and $z^{[j]}(t) \sim \mathcal{CN}(0, 1)$ is the complex additive white Gaussian noise (AWGN) at RX_j . The transmitted signal $x^{[i]}(t)$, $1 \leq i \leq K$, is subject to power constraint P , i.e., $\mathbb{E}[|x^{[i]}(t)|^2] \leq P$. The $K \times K$ channel matrix $\mathbf{H}(t)$ in time slot t is defined as $\mathbf{H}(t) \triangleq (h^{[ji]}(t))_{1 \leq i, j \leq K}$. The channel coefficients

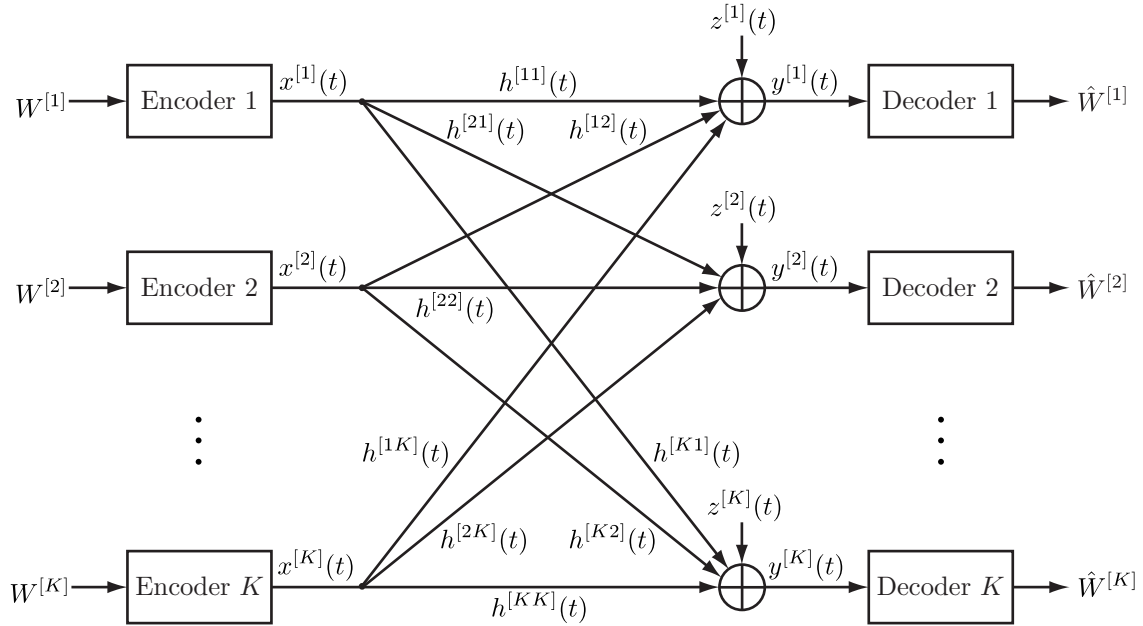
 Figure 3.1: K -user SISO interference channel

are i.i.d. across all nodes as well as time. The channel coefficients are assumed to be drawn according to a finite-variance continuous distribution.

An $M \times K$ X channel with private messages is a set of M transmitters and K receivers as depicted in Fig. 3.2, where TX_i , $1 \leq i \leq M$, has a message $W^{[i,j]} \in \{1, 2, 3, \dots, 2^{\tau R^{[i,j]}}\}$ of rate $R^{[i,j]}$ for each receiver RX_j , $1 \leq j \leq K$. The input-output relationship of this channel is given by

$$y^{[j]}(t) = \sum_{i=1}^M h^{[ji]}(t)x^{[i]}(t) + z^{[j]}(t), \quad (3.2)$$

with the same channel parameters as the IC and power constraint P at each transmitter. The channel matrix $\mathbf{H}(t)$ here is a $K \times M$ matrix defined as $\mathbf{H}(t) \triangleq (h^{[ji]}(t))_{1 \leq i \leq M, 1 \leq j \leq K}$. The X channel investigated in this chapter has $M = 2$ transmitters, although our achievable results are also valid for $M > 2$.

We make the following assumption about the knowledge of CSI at the transmitters and receivers:

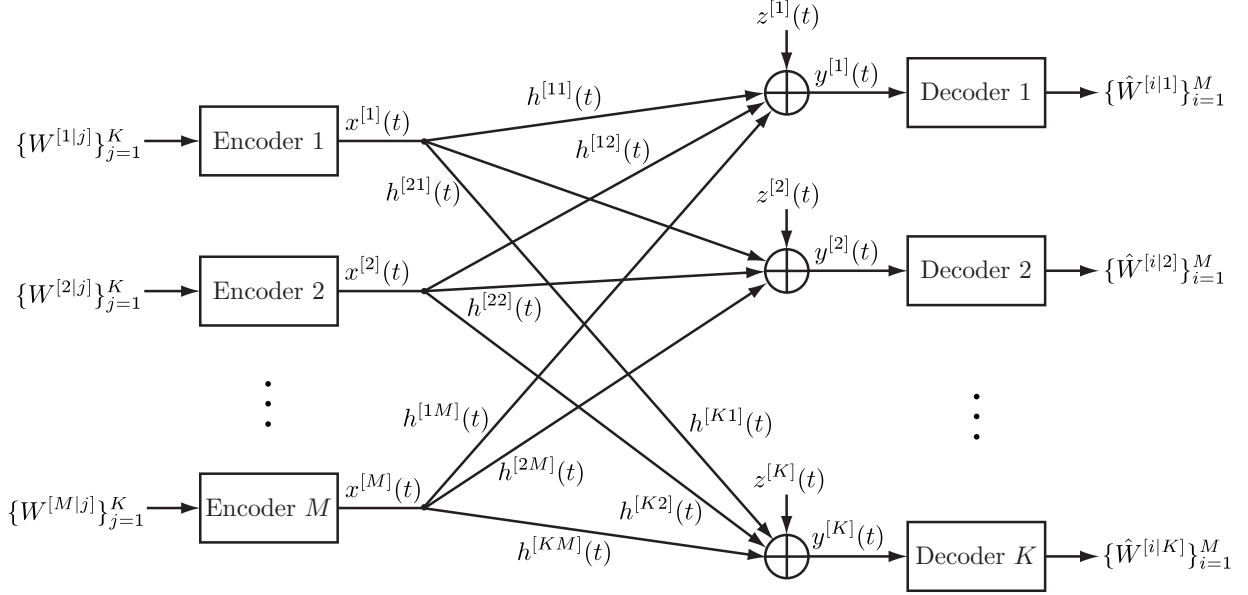
 Figure 3.2: $M \times K$ SISO X channel

Definition 5 (Delayed CSIT for IC and X Channel). *Each RX_j , $1 \leq j \leq K$, knows all its incoming channel coefficients in time slot t , i.e., $\{h^{[j;i]}(t)\}_{i=1}^K$ in the K -user IC and $\{h^{[j;i]}(t)\}_{i=1}^M$ in the $M \times K$ X channel, perfectly and instantaneously, while having access to the channel coefficients of the other receivers with one time slot delay. The channel matrix $\mathbf{H}(t)$ becomes available at all transmitters with one time slot delay via noiseless feedback links.*

We denote the side information available at TX_i before time slot t by $\mathcal{I}^{[i]}(t)$. Hence, under the delayed CSIT assumption, we have $\mathcal{I}^{[i]}(t) \triangleq \{\mathbf{H}(t')\}_{t'=1}^{t-1}$. A block code with feedback is defined as follows:

Definition 6 (Block Code with Feedback for IC and X Channel). *A $(2^{\tau \mathbf{R}}, \tau)$ code of block length τ and rate $\mathbf{R} = (R^{[i]})_{i=1}^K$ with feedback in the K -user IC is defined as K sets of encoding functions $\{\varphi_{t,\tau}^{[i]}\}_{t=1}^{\tau}$, $1 \leq i \leq K$, such that*

$$x^{[i]}(t) = \varphi_{t,\tau}^{[i]}(W^{[i]}, \mathcal{I}^{[i]}(t)), \quad 1 \leq t \leq \tau, \quad (3.3)$$

together with K decoding functions $\psi_{\tau}^{[j]}$, $1 \leq j \leq K$, such that

$$\hat{W}_{\tau}^{[j]} = \psi_{\tau}^{[j]}(\{y^{[j]}(t)\}_{t=1}^{\tau}, \{\mathbf{H}(t)\}_{t=1}^{\tau-1}, \{h^{[j;i]}(\tau)\}_{i=1}^K). \quad (3.4)$$

CHAPTER 3: SISO IC AND X CHANNEL WITH DELAYED CSIT

Similarly, A $(2^{\tau\mathbf{R}}, \tau)$ code of block length τ and rate $\mathbf{R} = (R^{[i,j]})_{1 \leq i \leq M, 1 \leq j \leq K}$ with feedback in the $M \times K$ X channel is defined as M sets of encoding functions $\{\varphi_{t,\tau}^{[i]}\}_{t=1}^{\tau}$, $1 \leq i \leq M$, such that

$$x^{[i]}(t) = \varphi_{t,\tau}^{[i]}(\{W^{[i,j]}\}_{j=1}^K, \mathcal{I}^{[i]}(t)), \quad 1 \leq t \leq \tau, \quad (3.5)$$

together with K decoding functions $\psi_{\tau}^{[j]}$, $1 \leq j \leq K$, such that

$$\{\hat{W}_{\tau}^{[i,j]}\}_{i=1}^M = \psi_{\tau}^{[j]}(\{y^{[j]}(t)\}_{t=1}^{\tau}, \{\mathbf{H}(t)\}_{t=1}^{\tau-1}, \{h^{[j,i]}(\tau)\}_{i=1}^M). \quad (3.6)$$

All encoding and decoding functions are revealed to all transmitters and receivers before the transmission begins. The probability of error, achievable rate, and capacity region are defined exactly as in Section 2.1. We study these channels in the limit of $P \rightarrow \infty$ and define their DoF as follows:

Definition 7 (DoF for IC and X Channel). *If $\mathbf{R}(P) = (R_1(P), R_2(P), \dots, R_N(P)) \in \mathcal{C}(P)$ is an achievable rate tuple, then $\mathbf{d} \triangleq \lim_{P \rightarrow \infty} \frac{\mathbf{R}(P)}{\log_2 P}$ is called an achievable DoF tuple and $d_1 + d_2 + \dots + d_N$ is called an achievable sum-DoF or simply achievable DoF. The closure of the set of all achievable DoF tuples is called the DoF region and denoted by \mathcal{D} , and the channel sum-DoF, or simply DoF, is defined as $\max_{\mathbf{d} \in \mathcal{D}} d_1 + d_2 + \dots + d_N$.*

In this dissertation, $\underline{\text{DoF}}_1^{\text{IC}}(K)$ and $\underline{\text{DoF}}_1^{\text{X}}(M, K)$ represent achievable DoFs for the K -user SISO IC and $M \times K$ SISO X channel with delayed CSIT, respectively. We indeed consider a more general transmission setup in this chapter: For the K -user SISO IC, fix an integer m , $1 \leq m \leq K$. Denote by \mathcal{S}_m a subset of cardinality m of $\{1, 2, \dots, K\}$. Obviously, $\mathcal{S}_K = \{1, 2, \dots, K\}$. For every subset $\mathcal{S}_m \subseteq \{1, 2, \dots, K\}$, and every $i \in \mathcal{S}_m$, TX_i wishes to communicate a common message $W^{[i|\mathcal{S}_m]}$ of rate $R^{[i|\mathcal{S}_m]}$ to all receivers RX_j , $j \in \mathcal{S}_m$. We call $W^{[i|\mathcal{S}_m]}$ an order- m message. The case $m = 1$ represents the interference channel with private messages as described earlier. The codes, probabilities of error, achievable rates, capacity region, and degrees of freedom are similarly defined as before, now for a $K \binom{K}{m-1}$ -tuple of rates. For any $1 \leq m \leq K$, an achievable DoF of transmission of order- m messages over the K -user SISO IC with delayed CSIT is denoted by $\underline{\text{DoF}}_m^{\text{IC}}(K)$.

Similarly, for the $M \times K$ X channel, fix an integer m , $1 \leq m \leq K$. For every subset $\mathcal{S}_m \subseteq \{1, 2, \dots, K\}$, and every $i \in \{1, 2, \dots, M\}$, TX_i wishes to communicate a common

CHAPTER 3: SISO IC AND X CHANNEL WITH DELAYED CSIT

message $W^{[i|\mathcal{S}_m]}$ of rate $R^{[i|\mathcal{S}_m]}$ to all receivers RX_j , $j \in \mathcal{S}_m$. The case $m = 1$ corresponds to the X channel with private messages. The achievable rates, capacity region, and degrees of freedom are similarly defined, now for an $M \binom{K}{m}$ -tuple of rates. An achievable DoF of this channel under delayed CSIT assumption is denoted by $\underline{\text{DoF}}_m^X(M, K)$ for $1 \leq m \leq K$.

Before proceeding with our results, let us introduce some notations which are widely used throughout this chapter.

Notation 3. We use $u^{[i|\mathcal{S}_m;\mathcal{S}_n]}$ to denote a symbol which is available at TX_i and also at every RX_j , $j \in \mathcal{S}_n$, and is intended to be decoded at every RX_k , $k \in \mathcal{S}_m$. We refer to $u^{[i|\mathcal{S}_m;\mathcal{S}_n]}$ as an $(\mathcal{S}_m; \mathcal{S}_n)$ -symbol available at TX_i . The order of symbol $u^{[i|\mathcal{S}_m;\mathcal{S}_n]}$ is defined as the ordered pair (m, n) containing the cardinalities of \mathcal{S}_m and \mathcal{S}_n , respectively. For instance, $u^{[2|1,5;3]}$ is a $(1, 5; 3)$ -symbol of order $(2, 1)$ which is available at TX_2 and RX_3 , and is intended to be decoded at both RX_1 and RX_5 , where the set braces “{” and “}” have been omitted to avoid cumbersome notations. For ease of notation, a symbol $u^{[i|\mathcal{S}_m;\mathcal{S}_n]}$ with $\mathcal{S}_n = \{\}$ is denoted by $u^{[i|\mathcal{S}_m]}$ and is called an \mathcal{S}_m -symbol of order m .

3.2 Main Results and Discussion

3.2.1 Main Results

The main results of this chapter are summarized in the following two theorems:

Theorem 3. The K -user ($K \geq 3$) SISO interference channel with delayed CSIT can achieve $\underline{\text{DoF}}_1^{\text{IC}}(K)$ degrees of freedom almost surely, where $\underline{\text{DoF}}_1^{\text{IC}}(K)$ is obtained by

$$\underline{\text{DoF}}_1^{\text{IC}}(K) = \left[1 - \frac{K-2}{K(K-1)^2} - \frac{K-2}{K-1} A_2(K) \right]^{-1}, \quad (3.7)$$

and $A_2(K)$ is given by

$$A_2(K) \triangleq -\frac{(K-2)(K-3)}{4[4(K-2)^2-1]} + \sum_{\ell_1=0}^{K-3} \frac{(K-\ell_1-1)(3\ell_1^2+\ell_1-1)}{2(K-\ell_1)(4\ell_1^2-1)} \prod_{\ell_2=\ell_1+1}^{K-2} \frac{\ell_2}{2\ell_2+1}. \quad (3.8)$$

CHAPTER 3: SISO IC AND X CHANNEL WITH DELAYED CSIT

Moreover, for $2 \leq m \leq K$, $\underline{\text{DoF}}_m^{\text{IC}}(K)$ degrees of freedom is achievable in transmission of order- m messages, where $\underline{\text{DoF}}_m^{\text{IC}}(K)$ is given by

$$\left[1 + \frac{(K-m)(K-m-1)}{2m[4(K-m)^2-1]} - \sum_{\ell_1=0}^{K-m-1} \frac{(K-m-\ell_1+1)(3\ell_1^2+\ell_1-1)}{2(K-\ell_1)(4\ell_1^2-1)} \prod_{j=\ell_1+1}^{K-m} \frac{\ell_2}{2\ell_2+1} \right]^{-1}. \quad (3.9)$$

Proof. See Section 3.3. □

Theorem 4. The $2 \times K$ SISO X channel with delayed CSIT can achieve $\underline{\text{DoF}}_1^{\text{X}}(2, K)$ degrees of freedom almost surely, where

$$\underline{\text{DoF}}_1^{\text{X}}(2, K) = \left[1 - \sum_{\ell_1=0}^{K-2} \frac{(K-1-\ell_1)(\ell_1+1)}{(K-\ell_1)(2\ell_1+1)} \prod_{\ell_2=\ell_1+1}^{K-1} \frac{\ell_2}{2\ell_2+1} \right]^{-1}. \quad (3.10)$$

More generally, for $2 \leq m \leq K$, $\underline{\text{DoF}}_m^{\text{X}}(2, K)$ degrees of freedom is achievable in transmission of order- m messages, where

$$\underline{\text{DoF}}_m^{\text{X}}(2, K) = \left[1 - \sum_{\ell_1=0}^{K-m-1} \frac{(K-m-\ell_1)(\ell_1+1)}{(K-\ell_1)(2\ell_1+1)} \prod_{\ell_2=\ell_1+1}^{K-m} \frac{\ell_2}{2\ell_2+1} \right]^{-1}. \quad (3.11)$$

Proof. See Section 3.4. □

3.2.2 Discussion

Our achievable DoFs for the K -user SISO IC and $2 \times K$ SISO X channel with private messages and delayed CSIT are plotted in Figs. 3.3 and 3.4 for $2 \leq K \leq 75$, respectively. For the sake of comparison, the achievable DoF reported in [23] for the $K \times K$ SISO X channel with delayed CSIT is also plotted in Fig. 3.4. As it is seen in the figure, for $K \geq 3$, our achievable DoF for the $2 \times K$ X channel, i.e., $\underline{\text{DoF}}_1^{\text{X}}(2, K)$ presented in Theorem 4, is strictly greater than $\frac{4}{3} - \frac{2}{3(3K-1)}$ which is achieved in [23] for the $K \times K$ X channel. It can be also easily shown that our achievable DoFs are strictly increasing in K , and it is proved in Appendix C that, as $K \rightarrow \infty$, the achievable DoFs approach limiting values of $\frac{4}{6 \ln 2 - 1} \approx 1.2663$ and $\frac{1}{\ln 2} \approx 1.4427$ for the IC and X channel, respectively. Tables 3.1

CHAPTER 3: SISO IC AND X CHANNEL WITH DELAYED CSIT

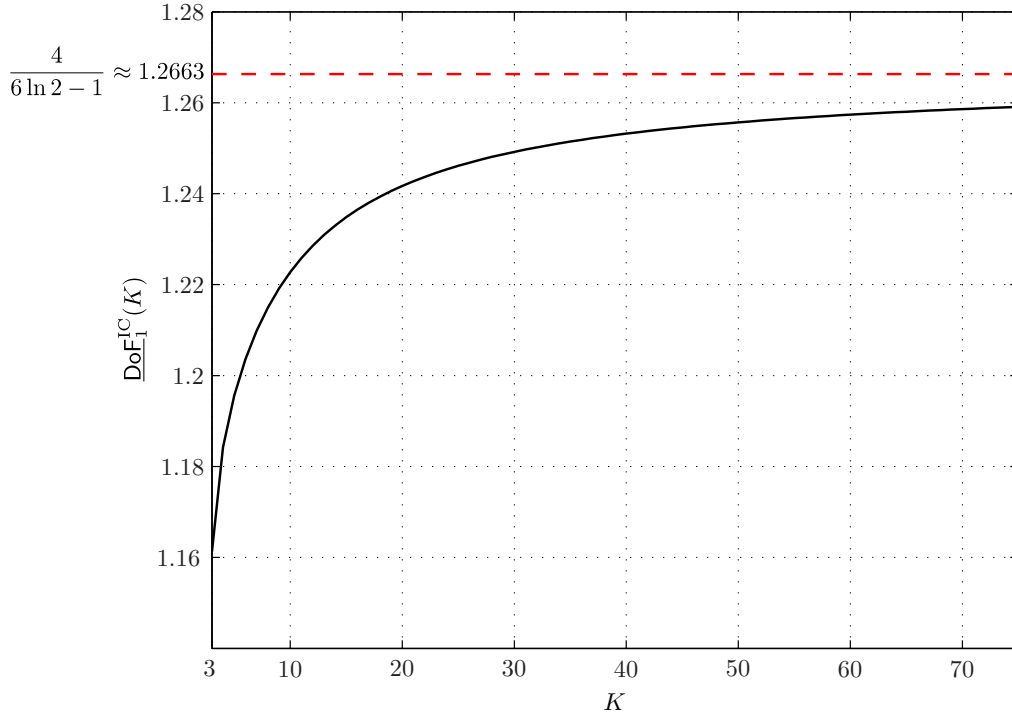

Figure 3.3: Our achievable DoF for the K -user SISO interference channel with delayed CSIT and $3 \leq K \leq 75$.

and 3.2 list our achievable DoFs for the K -user IC and $2 \times K$ X channel with delayed CSIT and $2 \leq K \leq 5$. For $K = 3$, we achieve $\frac{36}{31}$ DoF which is greater than the previously reported value of $\frac{9}{8}$ DoF in [35].

Remark 3. *Using scaled versions of the schemes proposed in Sections 3.3 and 3.4, $N \underline{\text{DoF}}_1^{\text{IC}}(K)$ and $N \underline{\text{DoF}}_1^{\text{X}}(2, K)$ are achievable in the K -user MIMO IC and $2 \times K$ MIMO X channel, respectively, with N antennas available at each node and with delayed CSIT.*

The schemes proposed in the next two sections for the K -user interference and $2 \times K$ X channels operate in K main phases: In phase 1, the transmitters send fresh information symbols together with some redundancy over time. The redundancy is such that “part” of the interference can be removed at each receiver by the end of this phase. Then, each transmitter exploits its knowledge of past CSI and its own transmitted information symbols to obtain the interference terms it caused at the non-intended receivers (if not already

CHAPTER 3: SISO IC AND X CHANNEL WITH DELAYED CSIT

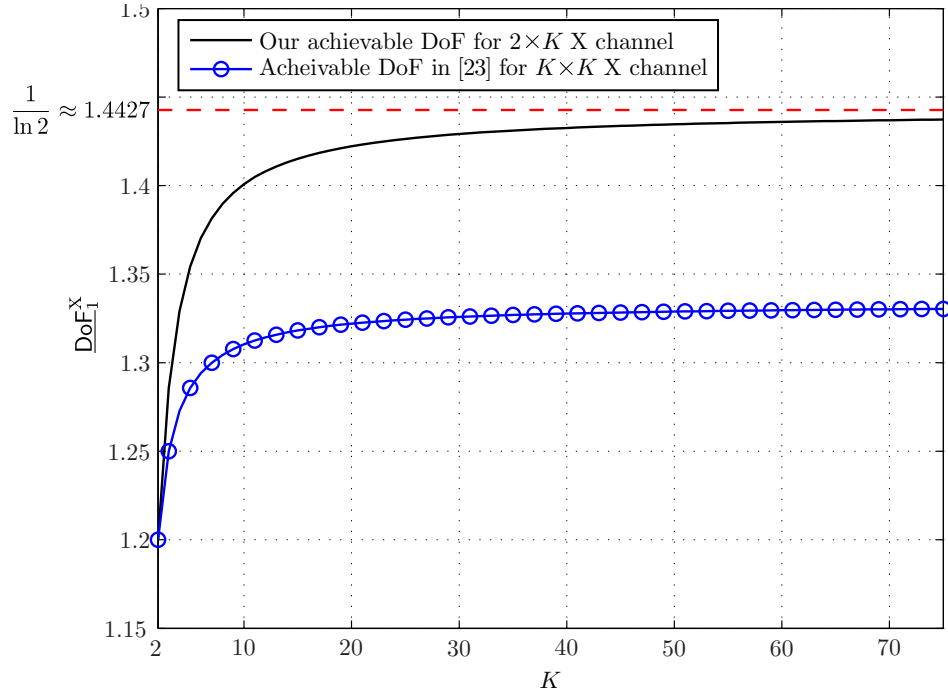

Figure 3.4: Our achievable DoF for the SISO X channel with delayed CSIT and $2 \leq K \leq 75$.

removed). Each of these interference terms, if being retransmitted, can align the past interference at a receiver while providing a useful linear combination for another receiver. Hence, they can be considered as common messages of order 2, which are desired by pairs of receivers, and are fed to the system in phase 2 together with some redundancy over time. The transmitted redundancy again helps some receivers to remove part of the interference. The transmitters again using the past CSI and their own transmitted order-2 messages, will obtain their non-removed interference terms at non-intended receivers. This yields

Table 3.1: Achievable DoFs for the K -user SISO interference channel with delayed CSIT

K	2	3	4	5
Our achievable DoF for the K -user IC	1	$\frac{36}{31}$	$\frac{45}{38}$	$\frac{1400}{1171}$

Table 3.2: Achievable DoFs for the $M \times K$ SISO X channel with delayed CSIT

K	2	3	4	5
Our achievable DoF for the $2 \times K$ X channel	$\frac{6}{5}$	$\frac{9}{7}$	$\frac{105}{79}$	$\frac{1575}{1163}$
Achievable DoF in [23] for the $K \times K$ X channel	$\frac{6}{5}$	$\frac{5}{4}$	$\frac{14}{11}$	$\frac{9}{7}$

generation of common messages for subsets of cardinality 3 of receivers. These order-3 messages, in turn, will be transmitted in phase 3, towards generation of order-4 messages. This procedure goes on phase by phase up to phase K where order- K messages will be delivered to all receivers without generating higher order messages.

Remark 4. *As mentioned in Chapter 2, the term “information symbol” in this dissertation refers to a symbol from an i.i.d. Gaussian codeword. Also, since the noise components which are observed by receivers in our transmission schemes have finite variances, they do not affect the DoF. Therefore, throughout this dissertation the noise is ignored in analysis of the transmission schemes.*

3.3 Proof of Theorem 3

In this section, we prove that $\underline{\text{DoF}}_m^{\text{IC}}(K)$, $1 \leq m \leq K$, stated in Theorem 3 can be achieved in the K -user SISO IC with delayed CSIT. To this end, we first elaborate on our achievable scheme for the case of $K = 3$. We then propose our transmission scheme for the general K -user setting.

3.3.1 The 3-user SISO Interference Channel with Delayed CSIT

In order to achieve $\underline{\text{DoF}}_1^{\text{IC}}(3) = 36/31$, suggested by (3.7), transmission is accomplished in three distinct phases. The fresh information symbols are fed to the channel in the first phase. In the remaining phases, extra linear equations are delivered to the receivers

CHAPTER 3: SISO IC AND X CHANNEL WITH DELAYED CSIT

in such a way that the interference is properly aligned at each receiver. At the end of transmission scheme, the receivers are left with the desired number of equations in terms of their respective information symbols.

It is important to point out that we will use several random coefficients during our transmission scheme to construct and transmit different channel input symbols. These coefficients are randomly generated and revealed to all transmitters and receivers before the beginning of communication. The transmission phases are described in detail as follows:

Phase 1 (3-user IC with Delayed CSIT): This phase takes 5 time slots, during which each transmitter feeds 4 fresh information symbols to the channel. Let $\mathbf{u}^{[i]} \triangleq [u_1^{[i]}, u_2^{[i]}, u_3^{[i]}, u_4^{[i]}]^T$ denote the vector containing the information symbols of TX $_i$, $1 \leq i \leq 3$. In each time slot, every transmitter transmits a random linear combination of its 4 information symbols. Let $\mathbf{c}^{[i]}(t) \triangleq [c_1^{[i]}(t), c_2^{[i]}(t), c_3^{[i]}(t), c_4^{[i]}(t)]^T$ denote the vector containing the random coefficients of the linear combination transmitted by TX $_i$, $1 \leq i \leq 3$, over time slot t , $1 \leq t \leq 5$, i.e., $x^{[i]}(t) = (\mathbf{c}^{[i]}(t))^T \mathbf{u}^{[i]}$. Ignoring the noise terms at receivers, the received signal at RX $_j$, $1 \leq j \leq 3$, in time slot t , $1 \leq t \leq 5$, is equal to

$$\begin{aligned} y^{[j]}(t) &= h^{[j1]}(t)x^{[1]}(t) + h^{[j2]}(t)x^{[2]}(t) + h^{[j3]}(t)x^{[3]}(t) \\ &= h^{[j1]}(t) (\mathbf{c}^{[1]}(t))^T \mathbf{u}^{[1]} + h^{[j2]}(t) (\mathbf{c}^{[2]}(t))^T \mathbf{u}^{[2]} + h^{[j3]}(t) (\mathbf{c}^{[3]}(t))^T \mathbf{u}^{[3]}. \end{aligned} \quad (3.12)$$

Therefore, by the end of phase 1, RX $_j$ obtains the following system of linear equations in terms of *all* transmitted information symbols:

$$\mathbf{y}^{[j]} = \mathbf{D}_{j1} \mathbf{C}^{[1]} \mathbf{u}^{[1]} + \mathbf{D}_{j2} \mathbf{C}^{[2]} \mathbf{u}^{[2]} + \mathbf{D}_{j3} \mathbf{C}^{[3]} \mathbf{u}^{[3]}, \quad 1 \leq j \leq 3, \quad (3.13)$$

where $\mathbf{y}^{[j]}$ is the 5×1 vector of received symbols at RX $_j$ during 5 time slots, \mathbf{D}_{ji} is the 5×5 diagonal matrix containing $h^{[ji]}(t)$, $1 \leq t \leq 5$, on its main diagonal, and $\mathbf{C}^{[i]}$ is the 5×4 matrix containing the random coefficients employed by TX $_i$ during these 5 time slots,

$$\mathbf{C}^{[i]} \triangleq [\mathbf{c}^{[i]}(1) | \mathbf{c}^{[i]}(2) | \mathbf{c}^{[i]}(3) | \mathbf{c}^{[i]}(4) | \mathbf{c}^{[i]}(5)]^T, \quad 1 \leq i \leq 3. \quad (3.14)$$

Since the elements of $\mathbf{C}^{[i]}$ are i.i.d., it is full rank almost surely, i.e., $\text{rank}(\mathbf{C}^{[i]}) = 4$. Furthermore, \mathbf{D}_{ji} is a diagonal matrix with i.i.d. elements on its main diagonal, and

CHAPTER 3: SISO IC AND X CHANNEL WITH DELAYED CSIT

thereby, it is also full rank almost surely, i.e., $\text{rank}(\mathbf{D}_{ji}) = 5$. Since $\mathbf{C}^{[i]}$ and \mathbf{D}_{ji} are independent of each other, their multiplication is also full rank almost surely. This means $\text{rank}(\mathbf{Q}_{ji}) = 4$, where $\mathbf{Q}_{ji} \triangleq \mathbf{D}_{ji}\mathbf{C}^{[i]}$, $1 \leq i, j \leq 3$. Since \mathbf{Q}_{ji} is a full rank 5×4 matrix, its *left null space* is one dimensional almost surely. As a result, for each (i, j) , $1 \leq i, j \leq 3$, there exists a nonzero 5×1 vector $\boldsymbol{\omega}_{ji} = [\omega_{ji1}, \omega_{ji2}, \omega_{ji3}, \omega_{ji4}, \omega_{ji5}]^T$ such that

$$\mathbf{Q}_{ji}^T \boldsymbol{\omega}_{ji} = \mathbf{0}_{4 \times 1}, \quad 1 \leq i, j \leq 3. \quad (3.15)$$

Note that by the end of phase 1, all transmitters and receivers have access to \mathbf{Q}_{ji} , $1 \leq i, j \leq 3$, and thus, can calculate $\boldsymbol{\omega}_{ji}$, $1 \leq i, j \leq 3$. Using (3.13) and (3.15), RX_1 can obtain

$$\begin{aligned} (\mathbf{y}^{[1]})^T \boldsymbol{\omega}_{13} &= (\mathbf{u}^{[1]})^T \mathbf{Q}_{11}^T \boldsymbol{\omega}_{13} + (\mathbf{u}^{[2]})^T \mathbf{Q}_{12}^T \boldsymbol{\omega}_{13} + (\mathbf{u}^{[3]})^T \overbrace{\mathbf{Q}_{13}^T \boldsymbol{\omega}_{13}}^{\mathbf{0}} \\ &= (\mathbf{u}^{[1]})^T \mathbf{Q}_{11}^T \boldsymbol{\omega}_{13} + (\mathbf{u}^{[2]})^T \mathbf{Q}_{12}^T \boldsymbol{\omega}_{13}, \end{aligned} \quad (3.16)$$

$$\begin{aligned} (\mathbf{y}^{[1]})^T \boldsymbol{\omega}_{12} &= (\mathbf{u}^{[1]})^T \mathbf{Q}_{11}^T \boldsymbol{\omega}_{12} + (\mathbf{u}^{[2]})^T \overbrace{\mathbf{Q}_{12}^T \boldsymbol{\omega}_{12}}^{\mathbf{0}} + (\mathbf{u}^{[3]})^T \mathbf{Q}_{13}^T \boldsymbol{\omega}_{12} \\ &= (\mathbf{u}^{[1]})^T \mathbf{Q}_{11}^T \boldsymbol{\omega}_{12} + (\mathbf{u}^{[3]})^T \mathbf{Q}_{13}^T \boldsymbol{\omega}_{12}. \end{aligned} \quad (3.17)$$

Similarly, RX_2 can obtain

$$(\mathbf{y}^{[2]})^T \boldsymbol{\omega}_{21} = (\mathbf{u}^{[2]})^T \mathbf{Q}_{22}^T \boldsymbol{\omega}_{21} + (\mathbf{u}^{[3]})^T \mathbf{Q}_{23}^T \boldsymbol{\omega}_{21}, \quad (3.18)$$

$$(\mathbf{y}^{[2]})^T \boldsymbol{\omega}_{23} = (\mathbf{u}^{[2]})^T \mathbf{Q}_{22}^T \boldsymbol{\omega}_{23} + (\mathbf{u}^{[1]})^T \mathbf{Q}_{21}^T \boldsymbol{\omega}_{23}, \quad (3.19)$$

and RX_3 can obtain

$$(\mathbf{y}^{[3]})^T \boldsymbol{\omega}_{31} = (\mathbf{u}^{[3]})^T \mathbf{Q}_{33}^T \boldsymbol{\omega}_{31} + (\mathbf{u}^{[2]})^T \mathbf{Q}_{32}^T \boldsymbol{\omega}_{31}, \quad (3.20)$$

$$(\mathbf{y}^{[3]})^T \boldsymbol{\omega}_{32} = (\mathbf{u}^{[3]})^T \mathbf{Q}_{33}^T \boldsymbol{\omega}_{32} + (\mathbf{u}^{[1]})^T \mathbf{Q}_{31}^T \boldsymbol{\omega}_{32}. \quad (3.21)$$

If we deliver $(\mathbf{u}^{[1]})^T \mathbf{Q}_{21}^T \boldsymbol{\omega}_{23}$, $(\mathbf{u}^{[2]})^T \mathbf{Q}_{12}^T \boldsymbol{\omega}_{13}$, $(\mathbf{u}^{[1]})^T \mathbf{Q}_{31}^T \boldsymbol{\omega}_{32}$, and $(\mathbf{u}^{[3]})^T \mathbf{Q}_{13}^T \boldsymbol{\omega}_{12}$ to RX_1 , then it can obtain enough equations to resolve its four desired information symbols as follows:

- $(\mathbf{u}^{[1]})^T \mathbf{Q}_{21}^T \boldsymbol{\omega}_{23}$ and $(\mathbf{u}^{[1]})^T \mathbf{Q}_{31}^T \boldsymbol{\omega}_{32}$ are two desired equations in terms of 4×1 information vector $\mathbf{u}^{[1]}$.

CHAPTER 3: SISO IC AND X CHANNEL WITH DELAYED CSIT

- $(\mathbf{u}^{[2]})^T \mathbf{Q}_{12}^T \boldsymbol{\omega}_{13}$ can be subtracted from $(\mathbf{y}^{[1]})^T \boldsymbol{\omega}_{13}$ to yield $(\mathbf{u}^{[1]})^T \mathbf{Q}_{11}^T \boldsymbol{\omega}_{13}$, which is a desired equation in terms of $\mathbf{u}^{[1]}$.
- $(\mathbf{u}^{[3]})^T \mathbf{Q}_{13}^T \boldsymbol{\omega}_{12}$ can be subtracted from $(\mathbf{y}^{[1]})^T \boldsymbol{\omega}_{12}$ to yield $(\mathbf{u}^{[1]})^T \mathbf{Q}_{11}^T \boldsymbol{\omega}_{12}$, which is a desired equation in terms of $\mathbf{u}^{[1]}$.

Therefore, RX₁ will have a system of four linear equations in terms of 4×1 information vector $\mathbf{u}^{[1]}$, namely, $(\mathbf{u}^{[1]})^T \mathbf{Q}_{21}^T \boldsymbol{\omega}_{23}$, $(\mathbf{u}^{[1]})^T \mathbf{Q}_{31}^T \boldsymbol{\omega}_{32}$, $(\mathbf{u}^{[1]})^T \mathbf{Q}_{11}^T \boldsymbol{\omega}_{13}$, and $(\mathbf{u}^{[1]})^T \mathbf{Q}_{11}^T \boldsymbol{\omega}_{12}$. As we prove in Appendix B.1, these equations are linearly independent almost surely, and therefore, RX₁ can solve them to obtain $\mathbf{u}^{[1]}$. By a similar argument, having $(\mathbf{u}^{[1]})^T \mathbf{Q}_{21}^T \boldsymbol{\omega}_{23}$, $(\mathbf{u}^{[2]})^T \mathbf{Q}_{12}^T \boldsymbol{\omega}_{13}$, $(\mathbf{u}^{[2]})^T \mathbf{Q}_{32}^T \boldsymbol{\omega}_{31}$, and $(\mathbf{u}^{[3]})^T \mathbf{Q}_{23}^T \boldsymbol{\omega}_{21}$, RX₂ can obtain four linearly independent equations in terms of $\mathbf{u}^{[2]}$, and so, it can solve them to obtain $\mathbf{u}^{[2]}$. Also, after providing RX₃ with $(\mathbf{u}^{[1]})^T \mathbf{Q}_{31}^T \boldsymbol{\omega}_{32}$, $(\mathbf{u}^{[3]})^T \mathbf{Q}_{13}^T \boldsymbol{\omega}_{12}$, $(\mathbf{u}^{[2]})^T \mathbf{Q}_{32}^T \boldsymbol{\omega}_{31}$, and $(\mathbf{u}^{[3]})^T \mathbf{Q}_{23}^T \boldsymbol{\omega}_{21}$, it can obtain enough equations to solve for $\mathbf{u}^{[3]}$.

Therefore, our goal in phase 2 boils down to delivering $(\mathbf{u}^{[1]})^T \mathbf{Q}_{21}^T \boldsymbol{\omega}_{23}$ and $(\mathbf{u}^{[2]})^T \mathbf{Q}_{12}^T \boldsymbol{\omega}_{13}$ to both RX₁ and RX₂, delivering $(\mathbf{u}^{[1]})^T \mathbf{Q}_{31}^T \boldsymbol{\omega}_{32}$ and $(\mathbf{u}^{[3]})^T \mathbf{Q}_{13}^T \boldsymbol{\omega}_{12}$ to both RX₁ and RX₃, and delivering $(\mathbf{u}^{[2]})^T \mathbf{Q}_{32}^T \boldsymbol{\omega}_{31}$ and $(\mathbf{u}^{[3]})^T \mathbf{Q}_{23}^T \boldsymbol{\omega}_{21}$ to both RX₂ and RX₃. Therefore, the following order-2 symbols can be defined:

$$u^{[1|1,2]} \triangleq (\mathbf{u}^{[1]})^T \mathbf{Q}_{21}^T \boldsymbol{\omega}_{23}, \quad u^{[1|1,3]} \triangleq (\mathbf{u}^{[1]})^T \mathbf{Q}_{31}^T \boldsymbol{\omega}_{32}, \quad (3.22)$$

$$u^{[2|1,2]} \triangleq (\mathbf{u}^{[2]})^T \mathbf{Q}_{12}^T \boldsymbol{\omega}_{13}, \quad u^{[2|2,3]} \triangleq (\mathbf{u}^{[2]})^T \mathbf{Q}_{32}^T \boldsymbol{\omega}_{31}, \quad (3.23)$$

$$u^{[3|1,3]} \triangleq (\mathbf{u}^{[3]})^T \mathbf{Q}_{13}^T \boldsymbol{\omega}_{12}, \quad u^{[3|2,3]} \triangleq (\mathbf{u}^{[3]})^T \mathbf{Q}_{23}^T \boldsymbol{\omega}_{21}. \quad (3.24)$$

Phase 2 (3-user IC with Delayed CSIT): This phase takes 12 time slots to transmit 18 order-2 symbols generated in phase 1. Since we have generated only 6 order-2 symbols in phase 1, we simply repeat phase 1 three times to obtain 18 order-2 symbols required in phase 2. This takes $3 \times 5 = 15$ time slots and hence, phase 2 begins at time slot $t = 16$. Consequently, at the beginning of phase 2, for every (i, j) , $1 \leq i, j \leq 3$, $i < j$, there are three order-2 symbols $u_1^{[i|i,j]}$, $u_2^{[i|i,j]}$, and $u_3^{[i|i,j]}$ at TX_{*i*} and three order-2 symbols $u_1^{[j|i,j]}$, $u_2^{[j|i,j]}$, and $u_3^{[j|i,j]}$ at TX_{*j*}. The transmission in phase 2 is then carried out as follows:

In the first time slot of phase 2, TX₁ transmits a random linear combination of $u_1^{[1|1,2]}$ and $u_2^{[1|1,2]}$ while TX₂ transmits $u_1^{[2|1,2]}$. In the second time slot, TX₁ transmits another

CHAPTER 3: SISO IC AND X CHANNEL WITH DELAYED CSIT

random linear combination of $u_1^{[1|1,2]}$ and $u_2^{[1|1,2]}$ while TX₂ repeats $u_1^{[2|1,2]}$. TX₃ is silent during these two time slots. After these two time slots, every receiver obtains two linearly independent equations in terms of three (1,2)-symbols $u_1^{[1|1,2]}$, $u_2^{[1|1,2]}$, and $u_1^{[2|1,2]}$ almost surely. Thus, each of RX₁ and RX₂ in order to resolve these three order-2 symbols, needs an extra equation. Consider the equations received at RX₃ during these two time slots:

$$y^{[3]}(t) = h^{[31]}(t)x^{[1]}(t) + h^{[32]}(t)x^{[2]}(t) = h^{[31]}(t) (\mathbf{c}^{[1|1,2]}(t))^T \mathbf{u}^{[1|1,2]} + h^{[32]}(t)u_1^{[2|1,2]}, \quad t = 16, 17, \quad (3.25)$$

where $\mathbf{u}^{[1|1,2]} \triangleq [u_1^{[1|1,2]}, u_2^{[1|1,2]}]^T$, and $\mathbf{c}^{[1|1,2]}(t) \triangleq [c_1^{[1|1,2]}(t), c_2^{[1|1,2]}(t)]^T$ is the 2×1 vector of random coefficients employed by TX₁ in time slot t . Now, RX₃ can form

$$\frac{1}{h^{[32]}(16)}y_3(16) - \frac{1}{h^{[32]}(17)}y_3(17) = \left[\frac{h^{[31]}(16)}{h^{[32]}(16)} (\mathbf{c}^{[1|1,2]}(16))^T - \frac{h^{[31]}(17)}{h^{[32]}(17)} (\mathbf{c}^{[1|1,2]}(17))^T \right] \mathbf{u}^{[1|1,2]}, \quad (3.26)$$

which is an equation solely in terms of the elements of $\mathbf{u}^{[1|1,2]}$. This is the side information that RX₃ has about the order-2 symbols of RX₁ and RX₂, and can provide the extra equation required by both RX₁ and RX₂ to resolve their order-2 symbols. Based on our terminology, this quantity is denoted by $u^{[1|1,2;3]}$. The next two time slots are dedicated to the transmission of another three order-2 (1,2)-symbols. However, this time, the roles of TX₁ and TX₂ are exchanged. Specifically, during time slots $t = 18, 19$, TX₂ transmits two random linear combinations of $u_2^{[2|1,2]}$ and $u_3^{[2|1,2]}$ while TX₁ repeats the same symbol $u_3^{[1|1,2]}$. The side information $u^{[2|1,2;3]}$ is similarly formed at RX₃ by the end of these two time slots.

Up to this point, we have sent 6 order-2 (1,2)-symbols in 4 time slots, and generated two pieces of side information at RX₃. Analogously, for each of receiver pairs $\{1, 3\}$ and $\{2, 3\}$, the above procedure can be repeated using their respective transmitters. Therefore, by spending another $2 \times 4 = 8$ time slots, we will transmit $2 \times 6 = 12$ order-2 symbols and generate the side information $u^{[2|2,3;1]}$ and $u^{[3|2,3;1]}$ at RX₁, and $u^{[1|1,3;2]}$ and $u^{[3|1,3;2]}$ at RX₂. Therefore, our goal is reduced to

- (a) delivering $u^{[1|1,2;3]}$ and $u^{[2|1,2;3]}$ to both RX₁ and RX₂,
- (b) delivering $u^{[1|1,3;2]}$ and $u^{[3|1,3;2]}$ to both RX₁ and RX₃,

CHAPTER 3: SISO IC AND X CHANNEL WITH DELAYED CSIT

(c) delivering $u^{[2|2,3;1]}$ and $u^{[3|2,3;1]}$ to both RX_2 and RX_3 .

To this end, consider a random linear combination $\alpha_1 u^{[1|1,2;3]} + \alpha_2 u^{[1|1,3;2]}$. If we deliver this quantity to all three receivers, then

- RX_1 obtains a linear equation in terms of its own desired symbols,
- since RX_2 has $u^{[1|1,3;2]}$, it can cancel $u^{[1|1,3;2]}$ to obtain $u^{[1|1,2;3]}$,
- since RX_3 has $u^{[1|1,2;3]}$, it can cancel $u^{[1|1,2;3]}$ to obtain $u^{[1|1,3;2]}$.

Therefore, $\alpha_1 u^{[1|1,2;3]} + \alpha_2 u^{[1|1,3;2]}$ is desired by all three receivers. By similar arguments, one can conclude that $\beta_1 u^{[2|2,1;3]} + \beta_2 u^{[2|2,3;1]}$ and $\gamma_1 u^{[3|1,3;2]} + \gamma_2 u^{[3|2,3;1]}$ are desired by all three receivers, where β_1 , β_2 , γ_1 , and γ_2 are random coefficients. According to our terminology, we define the following order-3 symbols:

$$u^{[1|1,2,3]} \triangleq \alpha_1 u^{[1|1,2;3]} + \alpha_2 u^{[1|1,3;2]}, \quad (3.27)$$

$$u^{[2|1,2,3]} \triangleq \beta_1 u^{[2|1,2;3]} + \beta_2 u^{[2|2,3;1]}, \quad (3.28)$$

$$u^{[3|1,2,3]} \triangleq \gamma_1 u^{[3|1,3;2]} + \gamma_2 u^{[3|2,3;1]}. \quad (3.29)$$

Although delivering $u^{[1|1,2,3]}$, $u^{[2|1,2,3]}$, and $u^{[3|1,2,3]}$ to all three receivers will provide each of them with useful information about its desired symbols as discussed above, it is not still sufficient to achieve the goals (a), (b), and (c). To be more specific, recall that RX_1 needs to obtain *both* symbols $u^{[1|1,2;3]}$ and $u^{[1|1,3;2]}$. Thus, assuming $u^{[1|1,2,3]}$ has been delivered to all three receivers, RX_1 still needs an extra equation in terms of $u^{[1|1,2;3]}$ and $u^{[1|1,3;2]}$. To obtain this extra equation, we notice that by delivering $u^{[1|1,2,3]}$ to all three receivers, both RX_2 and RX_3 will have both symbols $u^{[1|1,2;3]}$ and $u^{[1|1,3;2]}$. Therefore, any random linear combination $\alpha'_1 u^{[1|1,2;3]} + \alpha'_2 u^{[1|1,3;2]}$ can be considered as the extra equation required at RX_1 which is also available at RX_2 and RX_3 . Therefore, we can define the following (1; 2, 3)-symbol at TX_1 :

$$u^{[1|1;2,3]} \triangleq \alpha'_1 u^{[1|1,2;3]} + \alpha'_2 u^{[1|1,3;2]}. \quad (3.30)$$

By repeating the same argument for RX_2 and RX_3 , the following (2; 1, 3)-symbol and (3; 1, 2)-symbol can be defined:

$$u^{[2|2;1,3]} \triangleq \beta'_1 u^{[2|1,2;3]} + \beta'_2 u^{[2|2,3;1]}, \quad (3.31)$$

CHAPTER 3: SISO IC AND X CHANNEL WITH DELAYED CSIT

$$u^{[3|3;1,2]} \triangleq \gamma'_1 u^{[3|1,3;2]} + \gamma'_2 u^{[3|2,3;1]}, \quad (3.32)$$

where β'_1 , β'_2 , γ'_1 , and γ'_2 are random coefficients. To summarize, one can achieve the goals (a), (b), and (c) if:

- I. $u^{[1|1,2,3]}$, $u^{[2|1,2,3]}$, and $u^{[3|1,2,3]}$ are delivered to all three receivers.
- II. $u^{[1|1;2,3]}$, $u^{[2|2;1,3]}$, and $u^{[3|3;1,2]}$ are respectively delivered to RX₁, RX₂, and RX₃.

The goals I and II will be accomplished in the next phase.

Phase 3-I (3-user IC with Delayed CSIT): In this subphase, which takes three time slots, we fulfill the goal I as follows: Using time division in three consecutive time slots, the three symbols $u^{[1|1,2,3]}$, $u^{[2|1,2,3]}$, and $u^{[3|1,2,3]}$ will be delivered to all three receivers.

Phase 3-II (3-user IC with Delayed CSIT): In this subphase, the goal II is accomplished in one time slot by simultaneous transmission of symbols $u^{[1|1;2,3]}$, $u^{[2|2;1,3]}$, and $u^{[3|3;1,2]}$ by TX₁, TX₂, and TX₃, respectively.

Finally, in order to compute the achieved DoF, we note that a total of $3 \times 12 = 36$ fresh information symbols were fed to the system in phase 1. To deliver these information symbols to their intended receivers, we spent $3 \times 5 = 15$ time slots in phase 1, $3 \times 4 = 12$ time slots in phase 2, three time slots in subphase 3-I, and one time slot in subphase 3-II. Therefore, our achieved DoF is equal to

$$\underline{\text{DoF}}_1^{\text{IC}}(3) = \frac{36}{15 + 12 + 3 + 1} = \frac{36}{31}. \quad (3.33)$$

One finally notes that the proposed transmission scheme starting from the phase 2 was dedicated to transmission of order-2 messages to the receivers. Therefore, we have proved that $\underline{\text{DoF}}_2^{\text{IC}}(3) = \frac{18}{12+3+1} = \frac{9}{8}$ is achievable in the 3-user IC with delayed CSIT as suggested by (3.9). Also, $\underline{\text{DoF}}_3^{\text{IC}}(3) = 1$ was trivially achieved using time division in the phase 3-I.

3.3.2 The K -user SISO Interference Channel with Delayed CSIT

In this section, we generalize our multiphase transmission scheme to the K -user SISO IC with delayed CSIT and $K > 3$. The transmission scheme is a multiphase scheme wherein

CHAPTER 3: SISO IC AND X CHANNEL WITH DELAYED CSIT

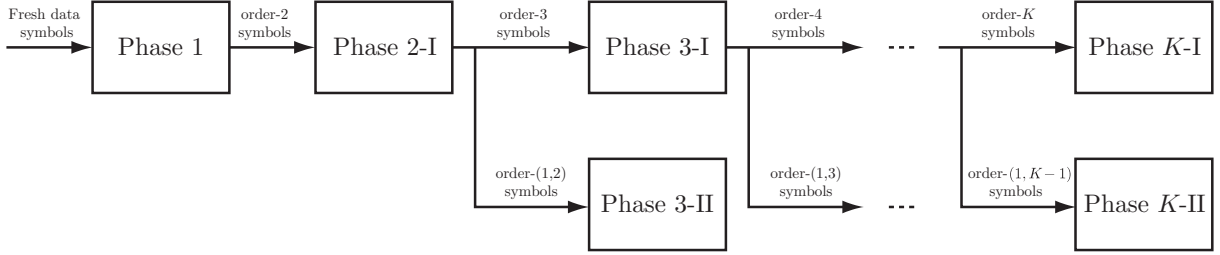

Figure 3.5: Block diagram of the proposed multiphase transmission scheme for the K -user IC, $K \geq 3$.

the fresh information symbols are fed to the system in phase 1 towards generating order-2 symbols. The remaining phases are responsible for generating higher order symbols and finally providing each receiver with appropriate equations to resolve its own information symbols. Fig. 3.5 depicts a high-level block diagram for the proposed multiphase scheme.

Phase 1 (K -user IC with Delayed CSIT): In this phase, each transmitter transmits $(K-1)^2 + 1$ random linear combinations of $(K-1)^2$ information symbols in $(K-1)^2 + 1$ time slots. Let $\mathbf{u}^{[i]} \triangleq [u_1^{[i]}, u_2^{[i]}, \dots, u_{(K-1)^2}^{[i]}]^T$ be the information vector of TX $_i$, $1 \leq i \leq K$. Define

$$\mathbf{C}^{[i]} \triangleq [\mathbf{c}^{[i]}(1) | \mathbf{c}^{[i]}(2) | \dots | \mathbf{c}^{[i]}((K-1)^2 + 1)]^T, \quad 1 \leq i \leq K, \quad (3.34)$$

where $\mathbf{c}^{[i]}(t)$ is the $(K-1)^2 \times 1$ vector of the random coefficients employed by TX $_i$ in time slot t , $1 \leq t \leq (K-1)^2 + 1$. Then, ignoring the noise, after these $(K-1)^2 + 1$ time slots, RX $_j$ receives the following vector of $(K-1)^2 + 1$ channel output symbols:

$$\mathbf{y}^{[j]} = \mathbf{D}_{j1} \mathbf{C}^{[1]} \mathbf{u}^{[1]} + \mathbf{D}_{j2} \mathbf{C}^{[2]} \mathbf{u}^{[2]} + \dots + \mathbf{D}_{jK} \mathbf{C}^{[K]} \mathbf{u}^{[K]}, \quad 1 \leq j \leq K, \quad (3.35)$$

where \mathbf{D}_{ji} is the diagonal matrix of size $[(K-1)^2 + 1] \times [(K-1)^2 + 1]$ which contains the channel coefficients $h^{[j]i}(t)$, $1 \leq t \leq (K-1)^2 + 1$, on its main diagonal.

Define $\mathbf{Q}_{ji} \triangleq \mathbf{D}_{ji} \mathbf{C}^{[i]}$, $1 \leq i, j \leq K$. Since \mathbf{D}_{ji} and $\mathbf{C}^{[i]}$ are full rank almost surely and independent of each other, their multiplication is also full rank almost surely. Hence, \mathbf{Q}_{ji} is a full rank matrix of size $[(K-1)^2 + 1] \times (K-1)^2$ almost surely, and so, its left null space is one dimensional. Therefore, there exist nonzero vectors $\boldsymbol{\omega}_{ji} = [\omega_{ji1}, \omega_{ji2}, \dots, \omega_{ji((K-1)^2+1)}]^T$ such that

$$\mathbf{Q}_{ji}^T \boldsymbol{\omega}_{ji} = \mathbf{0}_{(K-1)^2 \times 1}, \quad 1 \leq i, j \leq K. \quad (3.36)$$

CHAPTER 3: SISO IC AND X CHANNEL WITH DELAYED CSIT

Thus, for any $1 \leq j \leq K$ and any $i \in \mathcal{S}_K \setminus \{j\}$, RX_j can construct

$$(\mathbf{y}^{[j]})^T \boldsymbol{\omega}_{ji} = \sum_{i' \in \mathcal{S}_K \setminus \{i\}} (\mathbf{u}^{[i']})^T \mathbf{Q}_{ji'}^T \boldsymbol{\omega}_{ji} = (\mathbf{u}^{[j]})^T \mathbf{Q}_{jj}^T \boldsymbol{\omega}_{ji} + \sum_{i' \in \mathcal{S}_K \setminus \{i, j\}} (\mathbf{u}^{[i']})^T \mathbf{Q}_{ji'}^T \boldsymbol{\omega}_{ji}. \quad (3.37)$$

We note that $(\mathbf{u}^{[i']})^T \mathbf{Q}_{ji'}^T \boldsymbol{\omega}_{ji}$, $i' \in \mathcal{S}_K \setminus \{i, j\}$, is an equation solely in terms of $\mathbf{u}^{[i']}$, and thus, it is desired by $\text{RX}_{i'}$. It is easy to see that if we deliver *all* $K - 2$ quantities $(\mathbf{u}^{[i']})^T \mathbf{Q}_{ji'}^T \boldsymbol{\omega}_{ji}$, $i' \in \mathcal{S}_K \setminus \{i, j\}$, to RX_j , then RX_j can cancel their summation from (3.37) to obtain $(\mathbf{u}^{[j]})^T \mathbf{Q}_{jj}^T \boldsymbol{\omega}_{ji}$, which is a desired equation for RX_j . Therefore, one can define $K - 2$ order-2 (i', j) -symbols available at $\text{TX}_{i'}$ by

$$u^{[i'|i',j]} \triangleq (\mathbf{u}^{[i']})^T \mathbf{Q}_{ji'}^T \boldsymbol{\omega}_{ji}, \quad i' \in \mathcal{S}_K \setminus \{i, j\}. \quad (3.38)$$

Since for a fixed j there are $K - 1$ choices of i , $i \in \mathcal{S}_K \setminus \{j\}$, a total of $(K - 1)(K - 2)$ order-2 symbols of the form $u^{[i|i,j]}$, $i \in \mathcal{S}_K \setminus \{j\}$, will be constructed for a fixed j . These symbols, if delivered, will provide RX_j with $K - 1$ equations solely in terms of $\mathbf{u}^{[j]}$ while providing every RX_i , $i \in \mathcal{S}_K \setminus \{j\}$, with $K - 2$ equations in terms of $\mathbf{u}^{[i]}$.

Since there are K choices for RX_j , $1 \leq j \leq K$, a total of $K(K - 1)(K - 2)$ order-2 symbols $u^{[i|i,j]}$, $i \in \mathcal{S}_K \setminus \{j\}$, are generated by the end of phase 1. After delivering all these symbols to their intended pairs of receivers, every receiver will be provided with $K - 1 + (K - 1)(K - 2) = (K - 1)^2$ linear equations in terms of its own information symbols. Namely, RX_j will obtain the following $(K - 1)^2$ linear equations in terms of $\mathbf{u}^{[j]}$:

$$(\mathbf{u}^{[j]})^T \mathbf{Q}_{jj}^T \boldsymbol{\omega}_{ji_1}, \quad i_1 \in \mathcal{S}_K \setminus \{j\}, \quad (3.39)$$

$$(\mathbf{u}^{[j]})^T \mathbf{Q}_{i_2 j}^T \boldsymbol{\omega}_{i_2 i_3}, \quad i_2, i_3 \in \mathcal{S}_K \setminus \{j\}, i_2 \neq i_3. \quad (3.40)$$

It is proved in Appendix B.1 that these $(K - 1)^2$ equations are linearly independent almost surely, and thus, each receiver can resolve all its $(K - 1)^2$ information symbols.

Finally, it takes $\frac{K(K-1)(K-2)}{\text{DoF}_2^{\text{IC}}(K)}$ time slots to deliver all the order-2 symbols generated in phase 1 to their intended pairs of receivers. Hence, one can write

$$\text{DoF}_1^{\text{IC}}(K) = \frac{(K - 1)^2 K}{(K - 1)^2 + 1 + \frac{K(K-1)(K-2)}{\text{DoF}_2^{\text{IC}}(K)}}. \quad (3.41)$$

CHAPTER 3: SISO IC AND X CHANNEL WITH DELAYED CSIT

Phase m -I, $2 \leq m \leq K-1$ (K -user IC with Delayed CSIT): This subphase takes a total of $N_m^{\text{IC-I}}$ order- m symbols of the form $u^{[i|\mathcal{S}_m]}$, $\mathcal{S}_m \subset \mathcal{S}_K$, $i \in \mathcal{S}_m$, and transmits them to the receivers in T_m^{IC} time slots. Then, a total of $N_{m+1}^{\text{IC-I}}$ order- $(m+1)$ symbols of the form $u^{[i|\mathcal{S}_{m+1}]}$, $\mathcal{S}_{m+1} \subseteq \mathcal{S}_K$, $i \in \mathcal{S}_{m+1}$, together with $N_{m+1}^{\text{IC-II}}$ symbols of the form $u^{[i; \mathcal{S}_{m+1} \setminus \{i\}]}$, $\mathcal{S}_{m+1} \subseteq \mathcal{S}_K$, $i \in \mathcal{S}_{m+1}$, are generated such that if the generated symbols are delivered to their intended receiver(s), then every subset \mathcal{S}_m of cardinality m of receivers will be able to decode all the \mathcal{S}_m -symbols transmitted in this subphase. The parameters $N_m^{\text{IC-I}}$, T_m^{IC} , $N_{m+1}^{\text{IC-I}}$, and $N_{m+1}^{\text{IC-II}}$ are given by

$$N_m^{\text{IC-I}} = m[2(K-m) + 1] \binom{K}{m}, \quad (3.42)$$

$$T_m^{\text{IC}} = m(K-m+1) \binom{K}{m}, \quad (3.43)$$

$$N_{m+1}^{\text{IC-I}} = (m^2 - 1) \binom{K}{m+1}, \quad (3.44)$$

$$N_{m+1}^{\text{IC-II}} = (m+1) \binom{K}{m+1}. \quad (3.45)$$

The following is a detailed description of this subphase:

Fix $\mathcal{S}_m \subset \mathcal{S}_K$ and sort the elements of \mathcal{S}_m in ascending cyclic order. Fix $i_1 \in \mathcal{S}_m$ and let $i_2 \in \mathcal{S}_m$ be the element immediately after i_1 in that ordering. Consider vector $\mathbf{u}^{[i_1|\mathcal{S}_m]} \triangleq [u_1^{[i_1|\mathcal{S}_m]}, u_2^{[i_1|\mathcal{S}_m]}, \dots, u_{K-m+1}^{[i_1|\mathcal{S}_m]}]^T$ of $K-m+1$ \mathcal{S}_m -symbols available at TX_{i_1} and vector $\mathbf{u}^{[i_2|\mathcal{S}_m]} \triangleq [u_1^{[i_2|\mathcal{S}_m]}, u_2^{[i_2|\mathcal{S}_m]}, \dots, u_{K-m}^{[i_2|\mathcal{S}_m]}]^T$ of $K-m$ \mathcal{S}_m -symbols available at TX_{i_2} . In the first $K-m+1$ time slots of this subphase, TX_{i_1} and TX_{i_2} transmit $K-m+1$ random linear combinations of elements of $\mathbf{u}^{[i_1|\mathcal{S}_m]}$ and $\mathbf{u}^{[i_2|\mathcal{S}_m]}$, respectively, while the rest of transmitters are silent. Let $\mathbf{c}^{[i_1|\mathcal{S}_m]}(t)$ (resp. $\mathbf{c}^{[i_2|\mathcal{S}_m]}(t)$) be the $(K-m+1) \times 1$ vector (resp. $(K-m) \times 1$ vector) of the random coefficients employed by TX_{i_1} (resp. TX_{i_2}) in time slot t , $1 \leq t \leq K-m+1$. Then, ignoring the noise, by the end of these time slots, RX_j , $1 \leq j \leq K$, will have the following vector of $K-m+1$ channel output symbols:

$$\mathbf{y}^{[j]} = \mathbf{D}_{j i_1} \mathbf{C}^{[i_1|\mathcal{S}_m]} \mathbf{u}^{[i_1|\mathcal{S}_m]} + \mathbf{D}_{j i_2} \mathbf{C}^{[i_2|\mathcal{S}_m]} \mathbf{u}^{[i_2|\mathcal{S}_m]} \quad (3.46)$$

$$= \mathbf{Q}_{j i_1} \mathbf{u}^{[i_1|\mathcal{S}_m]} + \mathbf{Q}_{j i_2} \mathbf{u}^{[i_2|\mathcal{S}_m]}, \quad (3.47)$$

CHAPTER 3: SISO IC AND X CHANNEL WITH DELAYED CSIT

where $\mathbf{C}^{[i_1|\mathcal{S}_m]}$ and $\mathbf{C}^{[i_2|\mathcal{S}_m]}$ are defined as

$$\mathbf{C}^{[i_1|\mathcal{S}_m]} \triangleq [\mathbf{c}^{[i_1|\mathcal{S}_m]}(1)|\mathbf{c}^{[i_1|\mathcal{S}_m]}(2)|\dots|\mathbf{c}^{[i_1|\mathcal{S}_m]}(K-m+1)]^T, \quad (3.48)$$

$$\mathbf{C}^{[i_2|\mathcal{S}_m]} \triangleq [\mathbf{c}^{[i_2|\mathcal{S}_m]}(1)|\mathbf{c}^{[i_2|\mathcal{S}_m]}(2)|\dots|\mathbf{c}^{[i_2|\mathcal{S}_m]}(K-m+1)]^T, \quad (3.49)$$

$\mathbf{D}_{j_{i_1}}$ and $\mathbf{D}_{j_{i_2}}$ are the diagonal matrices of size $(K-m+1) \times (K-m+1)$ containing the channel coefficients $h^{[j_{i_1}]}(t)$ and $h^{[j_{i_2}]}(t)$, $1 \leq t \leq K-m+1$, on their main diagonal, respectively, and $\mathbf{Q}_{j_{i_1}}$ and $\mathbf{Q}_{j_{i_2}}$ are defined as $\mathbf{Q}_{j_{i_1}} \triangleq \mathbf{D}_{j_{i_1}} \mathbf{C}^{[i_1|\mathcal{S}_m]}$ and $\mathbf{Q}_{j_{i_2}} \triangleq \mathbf{D}_{j_{i_2}} \mathbf{C}^{[i_2|\mathcal{S}_m]}$.

Therefore, in specific, each receiver RX_j , $j \in \mathcal{S}_m$, obtains $K-m+1$ desired linearly independent equations in terms of the $2(K-m)+1$ transmitted \mathcal{S}_m -symbols, and thus, needs $K-m$ extra equations to resolve all the transmitted \mathcal{S}_m -symbols. It is easily verified that $\mathbf{Q}_{j_{i_2}}$, $1 \leq j \leq K$, is a full rank matrix of size $(K-m+1) \times (K-m)$ almost surely, and so, its left null space is one dimensional. Specifically, there exist nonzero vectors $\boldsymbol{\omega}_{j'_{i_2}}$ such that

$$\mathbf{Q}_{j'_{i_2}}^T \boldsymbol{\omega}_{j'_{i_2}} = \mathbf{0}, \quad j' \in \mathcal{S}_K \setminus \mathcal{S}_m. \quad (3.50)$$

Hence, each receiver $\text{RX}_{j'}$, $j' \in \mathcal{S}_K \setminus \mathcal{S}_m$, can construct $\mathbf{y}_{j'}^T \boldsymbol{\omega}_{j'_{i_2}} = (\mathbf{u}^{[i_1|\mathcal{S}_m]})^T \mathbf{Q}_{j'_{i_1}}^T \boldsymbol{\omega}_{j'_{i_2}}$ which is a linear combination in terms of $\mathbf{u}^{[i_1|\mathcal{S}_m]}$ and thus, if delivered to all receivers RX_j , $j \in \mathcal{S}_m$, can provide each of them with an extra equation in terms of their desired \mathcal{S}_m -symbols. On the other hand, the above linear combination is solely in terms of $\mathbf{u}^{[i_1|\mathcal{S}_m]}$ (available at TX_{i_1}) and the channel coefficients (available at TX_{i_1} , due to the delayed CSIT assumption, by the end of these $K-m+1$ time slots). Therefore, based on our terminology, one can define

$$\mathbf{u}^{[i_1|\mathcal{S}_m;j']} \triangleq (\mathbf{u}^{[i_1|\mathcal{S}_m]})^T \mathbf{Q}_{j'_{i_1}}^T \boldsymbol{\omega}_{j'_{i_2}}, \quad j' \in \mathcal{S}_K \setminus \mathcal{S}_m. \quad (3.51)$$

After delivering all these side information symbols to all receivers RX_j , $j \in \mathcal{S}_m$, each of them will obtain $K-m+1$ linear equations in terms of the $K-m+1$ transmitted \mathcal{S}_m -symbols. Namely, RX_j , $j \in \mathcal{S}_m$, will obtain the following equations:

$$\mathbf{Q}_{j_{i_1}} \mathbf{u}^{[i_1|\mathcal{S}_m]} + \mathbf{Q}_{j_{i_2}} \mathbf{u}^{[i_2|\mathcal{S}_m]} \quad (3.52)$$

$$(\mathbf{u}^{[i_1|\mathcal{S}_m]})^T \mathbf{Q}_{j'_{i_1}}^T \boldsymbol{\omega}_{j'_{i_2}}, \quad j' \in \mathcal{S}_K \setminus \mathcal{S}_m. \quad (3.53)$$

It is shown in Appendix B.2 that the above equations are linearly independent almost surely, which enables RX_j to solve them for $\mathbf{u}^{[i_1|\mathcal{S}_m]}$ and $\mathbf{u}^{[i_2|\mathcal{S}_m]}$.

CHAPTER 3: SISO IC AND X CHANNEL WITH DELAYED CSIT

We repeat the same procedure for every choice of $i_1 \in \mathcal{S}_m$, i.e., for each choice, we spend $K - m + 1$ time slots to transmit $2(K - m) + 1$ \mathcal{S}_m -symbols and generate $K - m$ side information symbols. This implies the transmission of a total of $m[2(K - m) + 1]$ \mathcal{S}_m -symbols in $m(K - m + 1)$ time slots and generation of $m(K - m)$ side information symbols. Since $\mathcal{S}_m \subset \mathcal{S}_K$ could be any subset with cardinality m , we transmit a total of $N_m^{\text{IC-1}}$ order- m symbols in T_m^{IC} time slots and generate $m(K - m) \binom{K}{m}$ side information symbols, where $N_m^{\text{IC-1}}$ and T_m^{IC} are given by (3.42) and (3.43).

In order to deliver the generated side information symbols to their respective intended receivers, fix a subset $\mathcal{S}_{m+1} \subseteq \mathcal{S}_K$ and an index $i_1 \in \mathcal{S}_{m+1}$. For every $j' \in \mathcal{S}_{m+1} \setminus \{i_1\}$, we have generated exactly one side information symbol $u^{[i_1|\mathcal{S}_{m+1} \setminus \{j'\};j']}$. Since there are m different choices for j' , $j' \in \mathcal{S}_{m+1} \setminus \{i_1\}$, we can identify m symbols of the form $u^{[i_1|\mathcal{S}_{m+1} \setminus \{j'\};j]}$ for fixed $\mathcal{S}_{m+1} \subseteq \mathcal{S}_K$ and $i_1 \in \mathcal{S}_{m+1}$. Moreover, every receiver $\text{RX}_{j'}$, $j' \in \mathcal{S}_{m+1} \setminus \{i_1\}$, has exactly one of these m symbols and wishes to obtain the rest, while RX_{i_1} wishes to obtain all the m symbols. Therefore, if we deliver $m - 1$ random linear combinations of these m symbols to all receivers in \mathcal{S}_{m+1} , then each of them (except for RX_{i_1}) will remove its known side information and obtain $m - 1$ linearly independent equations in terms of the $m - 1$ desired symbols almost surely and hence, decode all desired symbols. Thus, we define $m - 1$ \mathcal{S}_{m+1} -symbols as follows

$$u_\ell^{[i_1|\mathcal{S}_{m+1}]} \triangleq \sum_{j' \in \mathcal{S}_{m+1} \setminus \{i_1\}} \alpha_\ell^{[i_1|\mathcal{S}_{m+1} \setminus \{j'\};j']} u^{[i_1|\mathcal{S}_{m+1} \setminus \{j'\};j]}, \quad 1 \leq \ell \leq m - 1, \quad (3.54)$$

where $\alpha_\ell^{[i_1|\mathcal{S}_{m+1} \setminus \{j'\};j']}$, $j' \in \mathcal{S}_{m+1} \setminus \{i_1\}$, $1 \leq \ell \leq m - 1$, is a random coefficient.

Since RX_{i_1} wishes to obtain all the m symbols $u^{[i_1|\mathcal{S}_{m+1} \setminus \{j'\};j]}$, $j' \in \mathcal{S}_{m+1} \setminus \{i_1\}$, after delivering the above $m - 1$ linear equations to RX_{i_1} , it still requires one extra linearly independent equation to resolve all its desired symbols. However, recall that after delivering all the \mathcal{S}_{m+1} -symbols defined in (3.54) to all receivers $\text{RX}_{j'}$, $j' \in \mathcal{S}_{m+1}$, every receiver $\text{RX}_{j'}$, $j' \in \mathcal{S}_{m+1} \setminus \{i_1\}$, will be able to obtain *all* the m symbols $u^{[i_1|\mathcal{S}_{m+1} \setminus \{j'\};j]}$, $j' \in \mathcal{S}_{m+1} \setminus \{i_1\}$. Thereafter, any linear combination of the symbols $u^{[i_1|\mathcal{S}_{m+1} \setminus \{j'\};j]}$, $j' \in \mathcal{S}_{m+1} \setminus \{i_1\}$, will be available at every receiver $\text{RX}_{j'}$, $j' \in \mathcal{S}_{m+1} \setminus \{i_1\}$. In specific, we can define a new random

CHAPTER 3: SISO IC AND X CHANNEL WITH DELAYED CSIT

linear combination

$$u^{[i_1|i_1; \mathcal{S}_{m+1} \setminus \{i_1\}]} \triangleq \sum_{j' \in \mathcal{S}_{m+1} \setminus \{i_1\}} \alpha_m^{[i_1|\mathcal{S}_{m+1} \setminus \{j'\}; j']} u^{[i_1|\mathcal{S}_{m+1} \setminus \{j'\}; j']}, \quad (3.55)$$

as a symbol which is available at TX_{i_1} and at every receiver $\text{RX}_{j'}$, $j' \in \mathcal{S}_{m+1} \setminus \{i_1\}$, and is desired by RX_{i_1} .

Since there are $\binom{K}{m+1}$ choices of $\mathcal{S}_{m+1} \subseteq \mathcal{S}_K$, and $m+1$ choices of $i_1 \in \mathcal{S}_{m+1}$ for each \mathcal{S}_{m+1} , a total of $N_{m+1}^{\text{IC-I}}$ order- $(m+1)$ \mathcal{S}_{m+1} -symbols and $N_{m+1}^{\text{IC-II}}$ order- $(1, m)$ $(i_1; \mathcal{S}_{m+1} \setminus \{i_1\})$ -symbols will be generated where $N_{m+1}^{\text{IC-I}}$ and $N_{m+1}^{\text{IC-II}}$ are given by (3.44) and (3.45). If we deliver all the \mathcal{S}_{m+1} -symbols and $(i_1; \mathcal{S}_{m+1} \setminus \{i_1\})$ -symbols, $\mathcal{S}_{m+1} \subset \mathcal{S}_K$, $i_1 \in \mathcal{S}_{m+1}$, defined in (3.54) and (3.55) to their intended receiver(s), then each receiver will be able to decode all its desired order- m symbols transmitted in this subphase. This will be accomplished during the next phases.

Phase K -I (K -user IC with Delayed CSIT): In this subphase, in each time slot, an order- K symbol of the form $u^{[i|\mathcal{S}_K]}$, $i \in \mathcal{S}_K$, is transmitted by TX_i while the other transmitters are silent. After each time slot, ignoring the noise, each receiver receives the transmitted symbol without any interference. This implies that

$$\underline{\text{DoF}}_K^{\text{IC}}(K) = 1. \quad (3.56)$$

Phase m -II, $3 \leq m \leq K$ (K -user IC with Delayed CSIT): In this subphase, each time slot is dedicated to transmission of the order- $(1, m-1)$ symbols $u^{[i|i; \mathcal{S}_m \setminus \{i\}]}$, $i \in \mathcal{S}_m$, for a fixed \mathcal{S}_m , $\mathcal{S}_m \subset \mathcal{S}_K$. In specific, in the time slot dedicated to \mathcal{S}_m , every transmitter TX_i , $i \in \mathcal{S}_m$, transmits $u^{[i|i; \mathcal{S}_m \setminus \{i\}]}$, simultaneously. Since each receiver RX_j , $j \in \mathcal{S}_m$, has all symbols $u^{[i|i; \mathcal{S}_m \setminus \{i\}]}$, $i \in \mathcal{S}_m \setminus \{j\}$, it will decode its desired symbol (i.e., $u^{[j|j; \mathcal{S}_m \setminus \{j\}]}$) after this time slot. If we denote by $\underline{\text{DoF}}_m^{\text{IC-II}}(K)$ the achievable DoF of transmitting all $(i; \mathcal{S}_m \setminus \{i\})$ -symbols over the K -user SISO IC with delayed CSIT, then one can write

$$\underline{\text{DoF}}_m^{\text{IC-II}}(K) = m, \quad 3 \leq m \leq K. \quad (3.57)$$

Combining (3.42) to (3.45) and (3.57), we conclude that

$$\underline{\text{DoF}}_m^{\text{IC}}(K) = \frac{N_m^{\text{IC-I}}}{T_m^{\text{IC}} + \frac{N_{m+1}^{\text{IC-II}}}{\underline{\text{DoF}}_{m+1}^{\text{IC-II}}(K)} + \frac{N_{m+1}^{\text{IC-I}}}{\underline{\text{DoF}}_{m+1}^{\text{IC}}(K)}}$$

$$\begin{aligned}
 &= \frac{m[2(K-m)+1] \binom{K}{m}}{m(K-m+1) \binom{K}{m} + \frac{(m+1) \binom{K}{m+1}}{m+1} + \frac{(m^2-1) \binom{K}{m+1}}{\underline{\text{DoF}}_{m+1}^{\text{IC}}(K)}} \\
 &= \frac{m[2(K-m)+1]}{m(K-m+1) + \frac{K-m}{m+1} + \frac{(m-1)(K-m)}{\underline{\text{DoF}}_{m+1}^{\text{IC}}(K)}}, \quad 2 \leq m \leq K-1. \quad (3.58)
 \end{aligned}$$

In Appendix A.1, it is shown that (3.9) is a closed form solution to the recursive equation (3.58) with the initial condition (3.56) and $2 \leq m \leq K$. As a result, for $m = 2$, it is shown that

$$\underline{\text{DoF}}_2^{\text{IC}}(K) = \frac{1}{1 - A_2(K)}, \quad (3.59)$$

where $A_2(K)$ is given in (3.8). Equation (3.7) immediately follows from (3.8), (3.41) and (3.59).

3.4 Proof of Theorem 4

For $K = 2$, our transmission scheme achieves the same DoF of $6/5$ as the scheme proposed in [23]. Hence, we would rather start with $K = 3$ and elaborate on our transmission scheme for the 2×3 X channel with delayed CSIT. We show that it achieves $\underline{\text{DoF}}_1^{\text{X}}(2, 3) = \frac{9}{7}$ and $\underline{\text{DoF}}_2^{\text{X}}(2, 3) = \frac{9}{8}$, as suggested by (3.10) and (3.11). Then, we will proceed with the general $2 \times K$ case.

3.4.1 The 2×3 SISO X Channel

In this section, we prove that $\underline{\text{DoF}}_1^{\text{X}}(2, 3) = \frac{9}{7}$ and $\underline{\text{DoF}}_2^{\text{X}}(2, 3) = \frac{9}{8}$ are achievable in the 2×3 SISO X channel with delayed CSIT. To this end, we propose a transmission scheme which has three distinct phases:

Phase 1 (2×3 X Channel with Delayed CSIT): This phase takes 9 time slots to transmit 15 information symbols as follows: Fix $i_1 = 1$ and $i_2 = 2$. During the first 3 time slots, 5 information symbols $\mathbf{u}^{[i_1|1]} \triangleq [u_1^{[i_1|1]}, u_2^{[i_1|1]}, u_3^{[i_1|1]}]^T$ and $\mathbf{u}^{[i_2|1]} \triangleq [u_1^{[i_2|1]}, u_2^{[i_2|1]}]^T$ (all intended for RX_{i_1}) are transmitted by TX_{i_1} and TX_{i_2} , respectively. In specific, in

CHAPTER 3: SISO IC AND X CHANNEL WITH DELAYED CSIT

each of these 3 time slots, TX_{i_1} transmits a random linear combination of $u_1^{[i_1|1]}$, $u_2^{[i_1|1]}$, and $u_3^{[i_1|1]}$ while TX_{i_2} transmits a random linear combination of $u_1^{[i_2|1]}$ and $u_2^{[i_2|1]}$. Let $\mathbf{c}^{[i_1|1]}(t) \triangleq [c_1^{[i_1|1]}(t), c_2^{[i_1|1]}(t), c_3^{[i_1|1]}(t)]^T$ and $\mathbf{c}^{[i_2|1]}(t) \triangleq [c_1^{[i_2|1]}(t), c_2^{[i_2|1]}(t)]^T$ denote the vectors containing the random coefficients of the linear combinations transmitted by TX_{i_1} and TX_{i_2} , respectively, over time slot t , $1 \leq t \leq 3$.

After these 3 time slots, every receiver obtains 3 linearly independent equations in terms of the 5 transmitted information symbols almost surely. Thus, RX_1 in order to resolve these 5 desired information symbols, needs *two* more linearly independent equations. Now, consider the equations received at each of RX_2 and RX_3 in time slot t , $1 \leq t \leq 3$:

$$\begin{aligned} y^{[j]}(t) &= \sum_{k=1}^2 h^{[j i_k]}(t) x^{[i_k]}(t) \\ &= \sum_{k=1}^2 h^{[j i_k]}(t) (\mathbf{c}^{[i_k|1]}(t))^T \mathbf{u}^{[i_k|1]}, \quad j = 2, 3. \end{aligned} \quad (3.60)$$

The system of linear equations received at RX_j , $j = 2, 3$, by the end of these 3 time slots can be written as

$$\mathbf{y}^{[j|1]} = \sum_{k=1}^2 \mathbf{D}_{j i_k|1} \mathbf{C}^{[i_k|1]} \mathbf{u}^{[i_k|1]}, \quad j = 2, 3, \quad (3.61)$$

where $\mathbf{y}^{[j|1]}$ is the 3×1 vector of received symbols at RX_j during these 3 time slots, $\mathbf{D}_{j i_k|1}$ is the 3×3 diagonal matrix containing $h^{[j i_k]}(t)$, $1 \leq t \leq 3$, on its main diagonal, and $\mathbf{C}^{[i_1|1]}$ (resp. $\mathbf{C}^{[i_2|1]}$) is the 3×3 (resp. 3×2) matrix containing the random coefficients employed by TX_{i_1} (resp. TX_{i_2}) during these 3 time slots, i.e.,

$$\mathbf{C}^{[i_k|1]} \triangleq [\mathbf{c}^{[i_k|1]}(1) | \mathbf{c}^{[i_k|1]}(2) | \mathbf{c}^{[i_k|1]}(3)]^T, \quad k = 1, 2. \quad (3.62)$$

Since the elements of $\mathbf{C}^{[i_1|1]}$ and $\mathbf{C}^{[i_2|1]}$ are i.i.d., they are full rank almost surely, i.e., $\text{rank}(\mathbf{C}^{[i_1|1]}) = 3$ and $\text{rank}(\mathbf{C}^{[i_2|1]}) = 2$. One can verify that $\mathbf{D}_{j i_k|1}$ is also full rank almost surely and is independent of $\mathbf{C}^{[i_k|1]}$. Therefore, $\mathbf{Q}_{j i_k|1} \triangleq \mathbf{D}_{j i_k|1} \mathbf{C}^{[i_k|1]}$ is full rank almost surely. Specifically, $\mathbf{Q}_{j i_2|1}$ is a full rank 3×2 matrix, and thus, its left null space is one dimensional almost surely. Let the 3×1 vector $\boldsymbol{\omega}_{j i_2|1}$ be in the left null space of $\mathbf{Q}_{j i_2|1}$, i.e.,

$$\mathbf{Q}_{j i_2|1}^T \boldsymbol{\omega}_{j i_2|1} = \mathbf{0}_{2 \times 1}, \quad j = 2, 3. \quad (3.63)$$

CHAPTER 3: SISO IC AND X CHANNEL WITH DELAYED CSIT

After these 3 time slots, every receiver can calculate $\boldsymbol{\omega}_{j i_2|1}$, $j = 2, 3$. Then, using (3.61) and (3.63), RX_j , $j = 2, 3$, can obtain

$$\begin{aligned} (\mathbf{y}^{[j|1]})^T \boldsymbol{\omega}_{j i_2|1} &= (\mathbf{u}^{[i_1|1]})^T \mathbf{Q}_{j i_1|1}^T \boldsymbol{\omega}_{j i_2|1} + (\mathbf{u}^{[i_2|1]})^T \overbrace{\mathbf{Q}_{j i_2|1}^T \boldsymbol{\omega}_{j i_2|1}}^{\mathbf{0}} \\ &= (\mathbf{u}^{[i_1|1]})^T \mathbf{Q}_{j i_1|1}^T \boldsymbol{\omega}_{j i_2|1}, \end{aligned} \quad (3.64)$$

which is an equation solely in terms of $\mathbf{u}^{[i_1|1]}$. Therefore, if we deliver $(\mathbf{u}^{[i_1|1]})^T \mathbf{Q}_{j i_1|1}^T \boldsymbol{\omega}_{j i_2|1}$, $j = 2, 3$, to RX_1 , then it will have enough equations to resolve its 5 desired information symbols (it can be easily shown that these equations are linearly independent almost surely). Hence, two symbols $u^{[i_1|1;2]}$ and $u^{[i_1|1;3]}$ can be defined as

$$u^{[i_1|1;j]} \triangleq (\mathbf{u}^{[i_1|1]})^T \mathbf{Q}_{j i_1|1}^T \boldsymbol{\omega}_{j i_2|1}, \quad j = 2, 3. \quad (3.65)$$

In the same way, the following 5 fresh information symbols (now, all intended for RX_2) are transmitted during the next 3 time slots:

$$\mathbf{u}^{[i_1|2]} \triangleq [u_1^{[i_1|2]}, u_2^{[i_1|2]}, u_3^{[i_1|2]}]^T, \quad (3.66)$$

$$\mathbf{u}^{[i_2|2]} \triangleq [u_1^{[i_2|2]}, u_2^{[i_2|2]}]^T, \quad (3.67)$$

and the following two side information symbols are generated:

$$u^{[i_1|2;j]} \triangleq (\mathbf{u}^{[i_1|2]})^T \mathbf{Q}_{j i_1|2}^T \boldsymbol{\omega}_{j i_2|2}, \quad j = 1, 3, \quad (3.68)$$

where $\mathbf{Q}_{j i_1|2}^T$ and $\boldsymbol{\omega}_{j i_2|2}$ are similarly defined.

The same procedure is followed during the last 3 time slots to transmit another 5 fresh information symbols

$$\mathbf{u}^{[i_1|3]} \triangleq [u_1^{[i_1|3]}, u_2^{[i_1|3]}, u_3^{[i_1|3]}]^T, \quad (3.69)$$

$$\mathbf{u}^{[i_2|3]} \triangleq [u_1^{[i_2|3]}, u_2^{[i_2|3]}]^T, \quad (3.70)$$

which are all intended for RX_3 , and generate the two side information symbols

$$u^{[i_1|3;j]} \triangleq (\mathbf{u}^{[i_1|3]})^T \mathbf{Q}_{j i_1|3}^T \boldsymbol{\omega}_{j i_2|3}, \quad j = 1, 2, \quad (3.71)$$

CHAPTER 3: SISO IC AND X CHANNEL WITH DELAYED CSIT

with similar definitions of $\mathbf{Q}_{j i_1 | 3}^T$ and $\boldsymbol{\omega}_{j i_2 | 3}$.

After these 9 time slots, if we deliver the side information symbols defined in (3.65), (3.68) and (3.71) to their respective receivers, then each receiver will be able to decode all its own 5 information symbols. To this end, consider the linear combination $u^{[i_1|1;2]} + u^{[i_1|2;1]}$. If we deliver this linear combination to *both* RX₁ and RX₂, then RX₁ can cancel $u^{[i_1|2;1]}$ to obtain $u^{[i_1|1;2]}$. Similarly, RX₂ can cancel $u^{[i_1|1;2]}$ to obtain $u^{[i_1|2;1]}$. Note also that both $u^{[i_1|1;2]}$ and $u^{[i_1|2;1]}$ are available at TX_{*i*₁}, and so is their summation. Therefore, one can define the following order-2 symbol available at TX_{*i*₁}:

$$u^{[i_1|1,2]} \triangleq u^{[i_1|1;2]} + u^{[i_1|2;1]}. \quad (3.72)$$

The following order-2 symbols can be similarly defined:

$$u^{[i_1|1,3]} \triangleq u^{[i_1|1;3]} + u^{[i_1|3;1]}, \quad (3.73)$$

$$u^{[i_1|2,3]} \triangleq u^{[i_1|2;3]} + u^{[i_1|3;2]}. \quad (3.74)$$

Our goal in phase 2 is to deliver the above three order-2 symbols to their respective pairs of receivers.

Phase 2 (2×3 X Channel with Delayed CSIT): This phase takes 12 time slots to transmit 18 order-2 symbols generated in phase 1. Recall that in phase 1 we generated only three order-2 symbols $u^{[i_1|1,2]}$, $u^{[i_1|1,3]}$, and $u^{[i_1|2,3]}$ which are all available at TX_{*i*₁}, where $i_1 = 1$. As we will see later, the following 18 order-2 symbols are required for phase 2:

$$u_k^{[i|1,2]}, u_k^{[i|1,3]}, u_k^{[i|2,3]}, \quad i = 1, 2, \quad 1 \leq k \leq 3. \quad (3.75)$$

Therefore, we repeat phase 1 three times with $(i_1, i_2) = (1, 2)$ and three times with $(i_1, i_2) = (2, 1)$ to generate the above 18 order-2 symbols required for phase 2. The transmission in phase 2 is then accomplished as follows:

The first 4 time slots of phase 2 are dedicated to transmission of 6 (1, 2)-symbols $\{u_k^{[1|1,2]}\}_{k=1}^3$ and $\{u_k^{[2|1,2]}\}_{k=1}^3$. This is accomplished in exactly the same way as the first 4 time slots of phase 2 in Section 3.3.1, and the side information symbols $u^{[1|1,2;3]}$ and $u^{[2|1,2;3]}$ will be generated at RX₃. Similar to phase 2 of Section 3.3.1, the next 8 time slots are

CHAPTER 3: SISO IC AND X CHANNEL WITH DELAYED CSIT

dedicated to transmission of 6 $(1, 3)$ -symbols and 6 $(2, 3)$ -symbols. However, in contrast to Section 3.3.1, the $(1, 3)$ -symbols and $(2, 3)$ -symbols are here transmitted by TX₁ and TX₂. Hence, after these 8 time slots, the side information $u^{[1|2,3;1]}$ and $u^{[2|2,3;1]}$ will be generated at RX₁ and the side information $u^{[1|1,3;2]}$ and $u^{[2|1,3;2]}$ will be generated at RX₂.

Therefore, after these 12 time slots, our goal is reduced to

- (a) delivering $u^{[1|1,2;3]}$ and $u^{[2|1,2;3]}$ to both RX₁ and RX₂,
- (b) delivering $u^{[1|1,3;2]}$ and $u^{[2|1,3;2]}$ to both RX₁ and RX₃,
- (c) delivering $u^{[1|2,3;1]}$ and $u^{[2|2,3;1]}$ to both RX₂ and RX₃.

Now, consider $u^{[1|1,2;3]}$, $u^{[1|1,3;2]}$, and $u^{[1|2,3;1]}$. Note that these three symbols are available at TX₁, and so is any linear combination of them. Another observation is that each receiver has exactly one symbol out of these three symbols and requires the other *two*. Hence, if we deliver *two* random linear combinations of these three symbols to all receivers, then RX₁ can remove $u^{[1|2,3;1]}$ from the two linear combinations to obtain two random linear combinations solely in terms of $u^{[1|1,2;3]}$ and $u^{[1|1,3;2]}$, and so, solve them for $u^{[1|1,2;3]}$ and $u^{[1|1,3;2]}$. Likewise, RX₂ (resp. RX₃) can remove $u^{[1|1,3;2]}$ (resp. $u^{[1|1,2;3]}$) from the two random linear combinations and obtain two random linear equations solely in terms of its own pair of desired symbols, and resolve its desired symbols. Thus, the following two random linear combinations can be considered as order-3 symbols to be delivered to all three receivers in the next phase:

$$u_1^{[1|1,2,3]} \triangleq \alpha_1 u^{[1|1,2;3]} + \alpha_2 u^{[1|1,3;2]} + \alpha_3 u^{[1|2,3;1]}, \quad (3.76)$$

$$u_2^{[1|1,2,3]} \triangleq \alpha'_1 u^{[1|1,2;3]} + \alpha'_2 u^{[1|1,3;2]} + \alpha'_3 u^{[1|2,3;1]}. \quad (3.77)$$

Using the same arguments for $u^{[2|1,2;3]}$, $u^{[2|1,3;2]}$, and $u^{[2|2,3;1]}$, one can define the following order-3 symbols:

$$u_1^{[2|1,2,3]} \triangleq \beta_1 u^{[2|1,2;3]} + \beta_2 u^{[2|1,3;2]} + \beta_3 u^{[2|2,3;1]}, \quad (3.78)$$

$$u_2^{[2|1,2,3]} \triangleq \beta'_1 u^{[2|1,2;3]} + \beta'_2 u^{[2|1,3;2]} + \beta'_3 u^{[2|2,3;1]}, \quad (3.79)$$

where β_i and β'_i , $1 \leq i \leq 3$, are random coefficients.

CHAPTER 3: SISO IC AND X CHANNEL WITH DELAYED CSIT

Phase 3 (2×3 X Channel with Delayed CSIT): Using time division in 4 time slots, the 4 order-3 symbols $u_1^{[1|1,2,3]}$, $u_2^{[1|1,2,3]}$, $u_1^{[2|1,2,3]}$, and $u_2^{[2|1,2,3]}$ will be delivered to all three receivers.

At the end, in view of the fact that we have fed a total of $6 \times 15 = 90$ fresh information symbols to the system in $6 \times 9 = 54$ time slots in phase 1, and spent 12 time slots in phase 2 and 4 time slots in phase 3, the achieved DoF is equal to

$$\underline{\text{DoF}}_1^X(2, 3) = \frac{90}{54 + 12 + 4} = \frac{9}{7}. \quad (3.80)$$

Also, regarding the phases 2 and 3, we have $\underline{\text{DoF}}_2^X(2, 3) = \frac{18}{12+4} = \frac{9}{8}$, and $\underline{\text{DoF}}_3^X(2, 3) = 1$.

3.4.2 The $2 \times K$ SISO X Channel

Our transmission scheme for the $2 \times K$ SISO X channel with delayed CSIT is a multiphase scheme as depicted in Fig. 3.6. In particular, for every m , $1 \leq m \leq K - 1$, phase m takes N_m^X order- m symbols of the form $u^{[i|\mathcal{S}_m]}$, $\mathcal{S}_m \subset \mathcal{S}_K$, $i \in \{1, 2\}$, and transmits them to the receivers in T_m^X time slots. Then, a total of N_{m+1}^X order- $(m+1)$ symbols of the form $u^{[i|\mathcal{S}_{m+1}]}$, $\mathcal{S}_{m+1} \subseteq \mathcal{S}_K$, $i \in \{1, 2\}$ are generated such that if the generated symbols are delivered to their intended receivers, then every subset \mathcal{S}_m of cardinality m of receivers will be able to decode all the \mathcal{S}_m -symbols transmitted in phase m . The parameters N_m^X , T_m^X , and N_{m+1}^X are given by

$$N_m^X = 2[2(K - m) + 1] \binom{K}{m}, \quad (3.81)$$

$$T_m^X = 2(K - m + 1) \binom{K}{m}, \quad (3.82)$$

$$N_{m+1}^X = 2m \binom{K}{m+1}. \quad (3.83)$$

The following is a detailed description of phase m :

Phase m , $1 \leq m \leq K - 1$ ($2 \times K$ X Channel with Delayed CSIT): Fix $i_1 = 1$ and $i_2 = 2$. For every $\mathcal{S}_m \subset \mathcal{S}_K$, consider the following two vectors of \mathcal{S}_m -symbols:

$$\mathbf{u}^{[i_1|\mathcal{S}_m]} \triangleq \left[u_1^{[i_1|\mathcal{S}_m]}, u_2^{[i_1|\mathcal{S}_m]}, \dots, u_{K-m+1}^{[i_1|\mathcal{S}_m]} \right]^T, \quad (3.84)$$

CHAPTER 3: SISO IC AND X CHANNEL WITH DELAYED CSIT

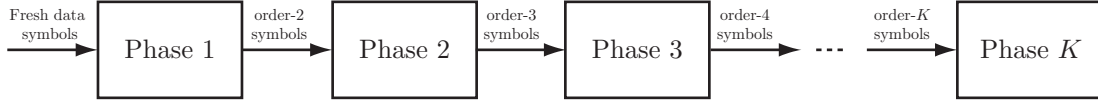

Figure 3.6: Block diagram of the proposed multiphase transmission scheme for the $2 \times K$ X channel, $K \geq 2$.

$$\mathbf{u}^{[i_2|\mathcal{S}_m]} \triangleq \left[u_1^{[i_2|\mathcal{S}_m]}, u_2^{[i_2|\mathcal{S}_m]}, \dots, u_{K-m}^{[i_2|\mathcal{S}_m]} \right]^T, \quad (3.85)$$

and transmit them exactly as the phase m -I of Section 3.3.2. More specifically, in $K - m + 1$ time slots, TX_{i_1} and TX_{i_2} transmit $K - m + 1$ random linear combinations of elements of $\mathbf{u}^{[i_1|\mathcal{S}_m]}$ and $\mathbf{u}^{[i_2|\mathcal{S}_m]}$, respectively. Using the same arguments as in the phase m -I of Section 3.3.2, $K - m$ side information symbols of the form $u^{[i_1|\mathcal{S}_m;j']}$, $j' \in \mathcal{S}_K \setminus \mathcal{S}_m$, are generated after these $K - m + 1$ time slots (see (3.51)). If we deliver all symbols $u^{[i_1|\mathcal{S}_m;j']}$, $j' \in \mathcal{S}_K \setminus \mathcal{S}_m$, to every receiver RX_j , $j \in \mathcal{S}_m$, then every receiver RX_j , $j \in \mathcal{S}_m$, will be obtain enough linearly independent equations to decode all the \mathcal{S}_m -symbols in $\mathbf{u}^{[i_1|\mathcal{S}_m]}$ and $\mathbf{u}^{[i_2|\mathcal{S}_m]}$.

Therefore, for every $\mathcal{S}_m \subset \mathcal{S}_K$, a total of $2(K - m) + 1$ \mathcal{S}_m -symbols are transmitted in $K - m + 1$ time slots, and $K - m$ side information symbols are generated. Since there are $\binom{K}{m}$ choices of $\mathcal{S}_m \subset \mathcal{S}_K$, this implies the transmission of $[2(K - m) + 1] \binom{K}{m}$ order- m symbols in $(K - m + 1) \binom{K}{m}$ time slots and generation of $(K - m) \binom{K}{m}$ side information symbols. Now, in order to deliver the generated side information symbols to their respective intended receivers, fix a subset $\mathcal{S}_{m+1} \subseteq \mathcal{S}_K$. For every $j' \in \mathcal{S}_{m+1}$, we have generated exactly one side information symbol $u^{[i_1|\mathcal{S}_{m+1} \setminus \{j'\};j']}$. Since there are $m + 1$ different choices for j' , $j' \in \mathcal{S}_{m+1}$, we can identify $m + 1$ symbols of the form $u^{[i_1|\mathcal{S}_{m+1} \setminus \{j'\};j]}$ for a fixed $\mathcal{S}_{m+1} \subseteq \mathcal{S}_K$. Moreover, every receiver $\text{RX}_{j'}$, $j' \in \mathcal{S}_{m+1}$, has exactly one of these $m + 1$ symbols and wishes to obtain the rest. Therefore, if we deliver m random linear combinations of these $m + 1$ symbols to all receivers in \mathcal{S}_{m+1} , then each of them will remove its known side information and obtain m linearly independent equations in terms of the m desired symbols almost surely and hence, decode all desired symbols. Thus, we define m \mathcal{S}_{m+1} -symbols as follows:

$$u_\ell^{[i_1|\mathcal{S}_{m+1}]} \triangleq \sum_{j' \in \mathcal{S}_{m+1}} \beta_\ell^{[i_1|\mathcal{S}_{m+1} \setminus \{j'\};j']} u^{[i_1|\mathcal{S}_{m+1} \setminus \{j'\};j]}, \quad 1 \leq \ell \leq m, \quad (3.86)$$

CHAPTER 3: SISO IC AND X CHANNEL WITH DELAYED CSIT

where $\beta_\ell^{[i_1|\mathcal{S}_{m+1}\setminus\{j'\};j']}$, $j' \in \mathcal{S}_{m+1}$, $1 \leq \ell \leq m$, is a random coefficient. Since there are $\binom{K}{m+1}$ choices of \mathcal{S}_{m+1} , $\mathcal{S}_{m+1} \subseteq \mathcal{S}_K$, a total of $m\binom{K}{m+1}$ order- $(m+1)$ symbols will be generated as above.

Finally we note that, so far, we have only generated order- $(m+1)$ symbols of the form $u^{[i_1|\mathcal{S}_{m+1}]}$, with $i_1 = 1$, which are all available at TX₁. However, in order for phase $m+1$ to work, we need order- $(m+1)$ symbols of *both* forms $u^{[1|\mathcal{S}_{m+1}]}$ and $u^{[2|\mathcal{S}_{m+1}]}$. This can be seen from (3.84) and (3.85). To resolve this issue, we simply repeat phase m with $(i_1, i_2) = (2, 1)$. This together with the previous round of phase m implies the transmission of a total of N_m^X order- m symbols in T_m^X time slots, and generation of N_{m+1}^X order- $(m+1)$ symbols, where N_m^X , T_m^X , and N_{m+1}^X are given by (3.81) to (3.83). If we deliver all these \mathcal{S}_{m+1} -symbols to their intended subsets of receivers, then each receiver will be able to decode all its desired order- m symbols transmitted in this phase. This will be accomplished during the next phases.

Phase K ($2 \times K$ X Channel with Delayed CSIT): In this phase, in each time slot, an order- K symbol of the form $u^{[i|\mathcal{S}_K]}$, $i \in \{1, 2\}$, is transmitted by TX _{i} while the other transmitter is silent. Therefore,

$$\underline{\text{DoF}}_K^X(2, K) = 1. \quad (3.87)$$

Finally, using (3.81) to (3.83), we can express $\underline{\text{DoF}}_m^X(2, K)$, the achieved DoF of transmission of order- m symbols in the $2 \times K$ SISO X channel with delayed CSIT, as

$$\begin{aligned} \underline{\text{DoF}}_m^X(2, K) &= \frac{N_m^X}{T_m^X + \frac{N_{m+1}^X}{\underline{\text{DoF}}_{m+1}^X(2, K)}} \\ &= \frac{2[2(K-m)+1]\binom{K}{m}}{2(K-m+1)\binom{K}{m} + \frac{2m\binom{K}{m+1}}{\underline{\text{DoF}}_{m+1}^X(2, K)}} \\ &= \frac{(m+1)[2(K-m)+1]}{(m+1)(K-m+1) + \frac{m(K-m)}{\underline{\text{DoF}}_{m+1}^X(2, K)}}, \quad 1 \leq m \leq K-1. \end{aligned} \quad (3.88)$$

It is proved in Appendix A.2 that (3.10) and (3.11) are indeed closed form expressions for $\underline{\text{DoF}}_m^X(2, K)$, $1 \leq m \leq K$, satisfying the recursive equation (3.88) together with the initial condition (3.87).

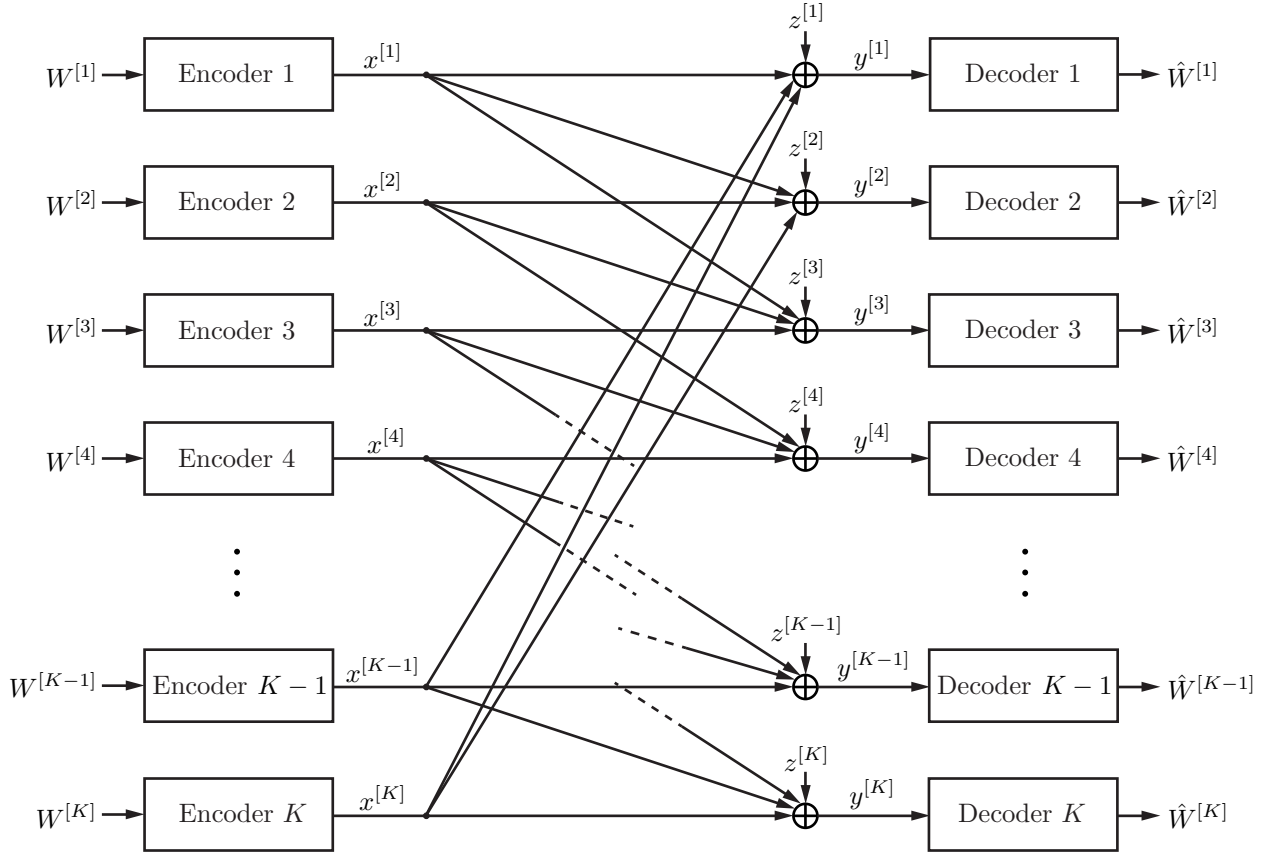
 Figure 3.7: K -user 3-cyclic SISO IC.

3.5 Cyclic SISO Interference Channel

In this section, we study the K -user r -cyclic SISO interference channel, $1 \leq r \leq K$. In this model, TX_i , $1 \leq i \leq K$, causes interference to $r - 1$ receivers $\text{RX}_{i+1}, \text{RX}_{i+2}, \dots, \text{RX}_{i+r-1}$ in a cyclic manner. Figure 3.7 depicts the block diagram of this channel. The case $r = K$ corresponds to the *fully connected* IC which was studied in Section 3.1. With full CSIT, it is known that this channel has $K/2$ DoF if $r \geq 2$ [10] and K DoF if $r = 1$. In the following, we first show that this channel has K/r DoF with no CSIT. Then, we focus on $r = 3$, and by generalizing our multiphase transmission ideas presented in Section 3.3.1, show that this channel can achieve more than $K/3$ DoF with delayed CSIT.

3.5.1 K -user r -cyclic Interference Channel with no CSIT

We prove that this channel has K/r DoF when there is no CSI available at the transmitters. To do so, we first show that K/r is an upper bound to the DoF of this channel. Consider the sub-channel which is composed of only the first r transmitter-receiver pairs $\{(\text{TX}_i, \text{RX}_i)\}_{i=1}^r$. Since adding interference does not increase the DoF, the sum-DoF of this sub-channel is an upper bound to the total DoF of *these users* in the original channel. Next, we show that the sum-DoF of this channel is upper bounded by 1.

Denote by $\mathbf{x}^{[i]} \triangleq [x^{[i]}(1), x^{[i]}(2), \dots, x^{[i]}(\tau)]^T$ and $\mathbf{y}^{[j]} \triangleq [y^{[j]}(1), y^{[j]}(2), \dots, y^{[j]}(\tau)]^T = \sum_{i=1}^j \mathbf{h}^{[ji]} \circ \mathbf{x}^{[i]} + \mathbf{z}^{[j]}$ the vectors transmitted by TX_i and received by RX_j over a block of τ time slots, where $\mathbf{h}^{[ji]} \triangleq [h^{[ji]}(1), h^{[ji]}(2), \dots, h^{[ji]}(\tau)]^T$ and $\mathbf{z}^{[j]} \triangleq [z^{[j]}(1), z^{[j]}(2), \dots, z^{[j]}(\tau)]^T$ and “ \circ ” denotes the element-wise product. Also, denote by $\mathbf{H}^{[j]} \triangleq [\mathbf{h}^{[ji]}]_{1 \leq i \leq j}$ the matrix of channel coefficients of RX_j over the block of τ time slots. By Fano’s inequality [16], we have

$$\tau R^{[j]} \leq I(\mathbf{x}^{[j]}; \mathbf{y}^{[j]}, \mathbf{H}^{[j]}) + \tau \epsilon_\tau \quad (3.89)$$

$$\stackrel{\text{(a)}}{=} I(\mathbf{x}^{[j]}; \mathbf{y}^{[j]} | \mathbf{H}^{[j]}) + \tau \epsilon_\tau, \quad j = 1, 2, \dots, r, \quad (3.90)$$

where $\epsilon_\tau \rightarrow 0$ as $\tau \rightarrow \infty$, and (a) follows from the fact that there is no CSI at the transmitters, and thus, $\mathbf{x}^{[j]}$ and $\mathbf{H}^{[j]}$ are independent of each other. Summing up the above inequalities for $1 \leq j \leq r$ and taking the limit as $\tau \rightarrow \infty$, we get

$$\sum_{j=1}^r R^{[j]} \leq \sum_{j=1}^r \lim_{\tau \rightarrow \infty} \frac{1}{\tau} I(\mathbf{x}^{[j]}; \mathbf{y}^{[j]} | \mathbf{H}^{[j]}), \quad (3.91)$$

$$= \sum_{j=1}^r \lim_{\tau \rightarrow \infty} \frac{1}{\tau} \left[h \left(\sum_{i=1}^j \mathbf{h}^{[ji]} \circ \mathbf{x}^{[i]} + \mathbf{z}^{[j]} \middle| \mathbf{H}^{[j]} \right) - h \left(\sum_{i=1}^{j-1} \mathbf{h}^{[ji]} \circ \mathbf{x}^{[i]} + \mathbf{z}^{[j]} \middle| \mathbf{H}^{[j]} \right) \right], \quad (3.92)$$

$$\stackrel{\text{(a)}}{=} \lim_{\tau \rightarrow \infty} \frac{1}{\tau} h(\mathbf{y}^{[r]} | \mathbf{H}^{[r]}), \quad (3.93)$$

where (a) uses the fact that the channel coefficients are i.i.d. across all nodes as well as time and the noise terms are also i.i.d. across receivers and time, and thus

$$h \left(\sum_{i=1}^{j-1} \mathbf{h}^{[(j-1)i]} \circ \mathbf{x}^{[i]} + \mathbf{z}^{[j-1]} \middle| \mathbf{H}^{[j-1]} \right) = h \left(\sum_{i=1}^{j-1} \mathbf{h}^{[ji]} \circ \mathbf{x}^{[i]} + \mathbf{z}^{[j]} \middle| \mathbf{H}^{[j]} \right). \quad (3.94)$$

CHAPTER 3: SISO IC AND X CHANNEL WITH DELAYED CSIT

Now, we can write

$$\sum_{j=1}^r d^{[j]} \leq \lim_{P \rightarrow \infty} \frac{1}{\log_2 P} \left(\lim_{\tau \rightarrow \infty} \frac{1}{\tau} h(\mathbf{y}^{[\tau]} | \mathbf{H}^{[j]}) \right) \leq 1, \quad (3.95)$$

where the last inequality follows the fact that a SISO point-to-point channel has at most 1 DoF.

Using the same arguments for similar sub-channels (which are selected in a cyclic manner), we get $\sum_{j=\ell}^{\ell+r-1} d^{[j]} \leq 1$ for every ℓ , $1 \leq \ell \leq K$. Summing up both sides of these inequalities for every ℓ , $1 \leq \ell \leq K$, we get $r \sum_{j=1}^K d^{[j]} \leq K$, which yields the desired upper bound.

Finally, it is easy to see that $\sum_{j=1}^K d^{[j]} = K/r$ is achievable with no CSIT as follows: In r time slots, each transmitter repeats only one information symbol. After r time slots, each receiver obtains r linearly independent combinations of r symbols (one desired symbols and $r - 1$ interference symbol), and hence, can resolve its desired symbol. The following theorem summarizes the above results:

Theorem 5. *The K -user r -cyclic SISO IC has K/r DoF with no CSIT.*

3.5.2 K -user 3-cyclic Interference Channel with Delayed CSIT

We note that when $r = 1$ the r -cyclic channel turns to a K -user interference-free channel which has K DoF with or without CSIT. Also, for $r = 2$, this channel is called cyclic Z-interference channel which has $K/2$ DoF with or without CSIT. Therefore, these channels have the same DoFs also with delayed CSIT. For $r > 2$, there is a strict gap between DoFs with full and no CSIT. In this case, focusing on $r = 3$, we show that more than $K/3$ DoF can be achieved in the 3-cyclic IC with delayed CSIT. In specific, we prove the following theorem:

Theorem 6. *The K -user 3-cyclic IC ($K \geq 3$) with delayed CSIT can achieve $\underline{\text{DoF}}_1^{\text{IC}}(K, 3)$ DoF almost surely, where*

$$\underline{\text{DoF}}_1^{\text{IC}}(K, 3) = \begin{cases} \frac{4K^2}{11K-2\lfloor \frac{K}{3} \rfloor}, & K \neq 5 \\ \frac{15}{8}, & K = 5 \end{cases}. \quad (3.96)$$

CHAPTER 3: SISO IC AND X CHANNEL WITH DELAYED CSIT

Proof. Consider the following transmission scheme which has three phases: In phase 1, $4K$ fresh information symbols are transmitted over 5 time slots, exactly as in the scheme proposed for the 3-user IC with delayed CSIT in Section 3.3.1. In particular, each transmitter transmits 5 random linear combinations of 4 information symbols in 5 time slots. Then, $2K$ order-2 symbols $u^{[j-1|j-1,j]}$, $u^{[j-2|j-2,j]}$, $1 \leq j \leq K$, will be generated accordingly. Therefore, the achievable DoF is obtained by

$$\underline{\text{DoF}}_1^{\text{IC}}(K, 3) = \frac{4K}{5 + \frac{2K}{\underline{\text{DoF}}_2^{\text{IC}}(K, 3)}}, \quad (3.97)$$

where $\underline{\text{DoF}}_2^{\text{IC}}(K, 3)$ denotes our achievable DoF for transmission of the order-2 symbols. In phase 2, the generated order-2 symbols are transmitted over the channel. Three different cases of $K = 3L$, $K = 3L + 1$, and $K = 3L + 2$ are treated separately. We define an “order-2 transmission graph” as a bipartite graph with $2K$ vertices corresponding to the $2K$ nodes of the channel under consideration. In this graph, TX_i is connected to RX_i and RX_j if and only if $u^{[i|i,j]}$ is transmitted by TX_i .

Phase 2 (K -user 3-cyclic IC with $K = 3L$):

Spend 2 time slots. In each time slot, for every $1 \leq m \leq L$,

- TX_{3m-2} transmits a random linear combination of $u_1^{[3m-2|3m-2,3m-1]}$ and $u_2^{[3m-2|3m-2,3m-1]}$.
- TX_{3m-1} repeats $u^{[3m-1|3m-1,3m+1]}$.
- TX_{3m} is silent.

After these 2 time slots, for every $1 \leq m \leq L$, RX_{3m-2} obtains 2 equations in terms of 3 desired symbols $u_1^{[3m-2|3m-2,3m-1]}$, $u_2^{[3m-2|3m-2,3m-1]}$, and $u^{[3m-4|3m-4,3m-2]}$. Also, RX_{3m-1} obtains 2 equations in terms of 3 desired symbols $u_1^{[3m-2|3m-2,3m-1]}$, $u_2^{[3m-2|3m-2,3m-1]}$, and $u^{[3m-1|3m-1,3m+1]}$. Hence, each of them requires one extra linearly independent combination to resolve its own symbols. Now, using the same arguments as in Section 3.3.1, for every $1 \leq m \leq L$, RX_{3m} can remove $u^{[3m-1|3m-1,3m+1]}$ to obtain a linear equation solely in terms of $u_1^{[3m-2|3m-2,3m-1]}$ and $u_2^{[3m-2|3m-2,3m-1]}$. This equation is desired by both RX_{3m-2} and RX_{3m-1} , and is denoted as $u^{[3m|3m-2,3m-1;3m]}$. These symbols will be delivered to their

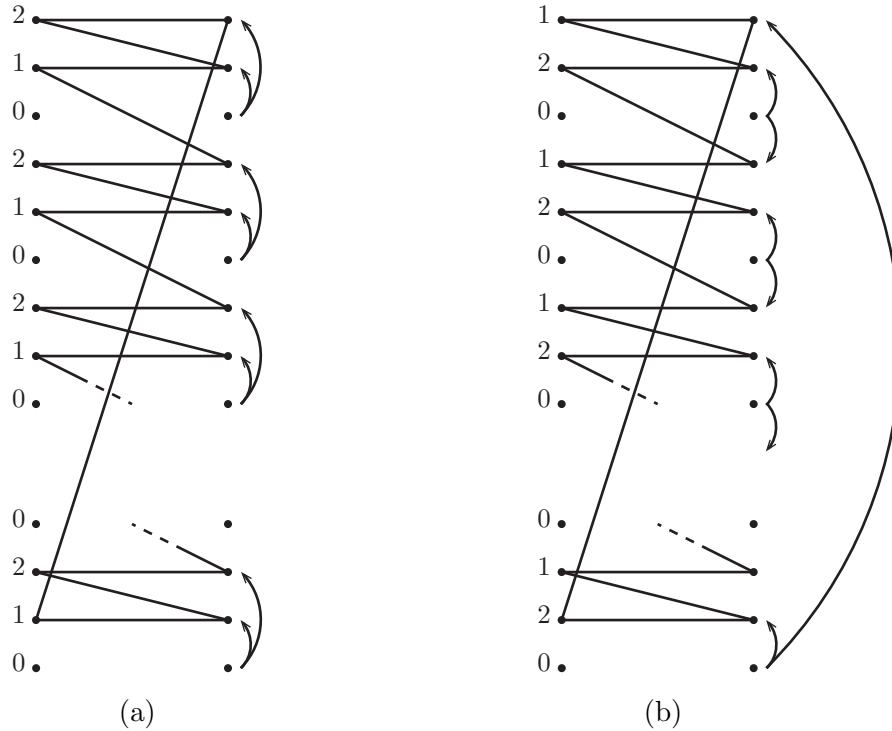

Figure 3.8: Order-2 transmission graph for K -user 3-cyclic SISO IC with $K = 3L$.

respective pairs of receivers in phase 3. Figure 3.8a depicts the transmission graph of phase 2. The number of fresh order-2 symbols transmitted by each transmitter is indicated in the figure next to its corresponding node. Also, the curved arrows show the pairs of receivers which require the side information available at each RX_{3m} , $1 \leq m \leq L$.

In order to transmit the same number of each order-2 symbol, we repeat this phase. However, we now follow the transmission strategy of Fig. 3.8b. Also, we make 4 new strategies by making one and two cyclic shifts to each graph in Fig. 3.8. Therefore, 3 order-2 symbols of each type are transmitted in this phase. That is, transmission of a total of $3 \times 2K = 6K$ order-2 symbols in $3 \times 2 \times 2 = 12$ time slots and generation of $2K$ side information symbols $u^{[i|i,i+1;i+2]}$, $u^{[i|i,i+2;i+1]}$, $1 \leq i \leq K$. The achieved DoF is then given by

$$\underline{\text{DoF}}_2^{\text{IC}}(K, 3) = \frac{6K}{12 + \frac{2K}{\underline{\text{DoF}}_{2;1}^{\text{IC}}(K, 3)}} \quad (3.98)$$

CHAPTER 3: SISO IC AND X CHANNEL WITH DELAYED CSIT

$$= \frac{K}{2 + \frac{L}{\underline{\text{DoF}}_{2;1}^{\text{IC}}(K,3)}}, \quad K = 3L, \quad (3.99)$$

where $\underline{\text{DoF}}_{2;1}^{\text{IC}}(K, 3)$ denotes the achievable DoF for transmission of the side information symbols of type $u^{[i|i,i+1;i+2]}$ or $u^{[i|i,i+2;i+1]}$.

Phase 2 (K -user 3-cyclic IC with $K = 3L + 1$):

In this case, the transmission graphs of Figs. 3.9a and 3.9b are used to transmit order-2 symbols. However, it can be seen that in each of these graphs RX_2 receives an interference term from TX_K , i.e., the symbol $u^{[K|K,1]}$. Hence, after delivering the side information symbols generated in this phase (generated exactly as in the case of $K = 3L$), RX_2 still needs to decode this symbol to be able to decode all its desired symbols. But, we notice that this symbol will be available at RX_1 and RX_K after delivering the side information symbols. Therefore, one can denote this symbol as $u^{[K|2;K,1]}$.

It can be verified that by $L - 1$ times repeating the K cyclically shifted versions of graph of Fig. 3.9a together with $L + 1$ times repeating the K cyclically shifted versions of graph of Fig. 3.9b, we can transmit LK order-2 symbols of each type, i.e., a total of $2LK^2$ order-2 symbols. To do so, we spend a total of $4LK$ time slots, and will generate $(L - 1)LK$ symbols of type $u^{[i|i,i+1;i+2]}$, $(L + 1)LK$ symbols of type $u^{[i|i,i+2;i+1]}$, and $2LK$ symbols of type $u^{[i|i+2;i,i+1]}$. Therefore, we get

$$\underline{\text{DoF}}_2^{\text{IC}}(K, 3) = \frac{2LK^2}{4LK + \frac{2L^2K}{\underline{\text{DoF}}_{2;1}^{\text{IC}}(K,3)} + \frac{2LK}{\underline{\text{DoF}}_{1;2}^{\text{IC}}(K,3)}} \quad (3.100)$$

$$= \frac{K}{2 + \frac{L}{\underline{\text{DoF}}_{2;1}^{\text{IC}}(K,3)} + \frac{1}{\underline{\text{DoF}}_{1;2}^{\text{IC}}(K,3)}}, \quad K = 3L + 1, \quad (3.101)$$

where $\underline{\text{DoF}}_{1;2}^{\text{IC}}(K, 3)$ denotes the achievable DoF for transmission of the side information symbols of type $u^{[i|i+2;i,i+1]}$, and we have used the fact that the total number of generated symbols of type $u^{[i|i,i+1;i+2]}$ or $u^{[i|i,i+2;i+1]}$ is equal to $(L - 1)LK + (L + 1)LK = 2L^2K$.

Phase 2 (K -user 3-cyclic IC with $K = 3L + 2$):

In this case, if $L \geq 2$, the transmission graphs of Figs. 3.9c and 3.9d are used to transmit order-2 symbols. It can be verified that by $L + 2$ times repeating the K cyclically shifted

CHAPTER 3: SISO IC AND X CHANNEL WITH DELAYED CSIT

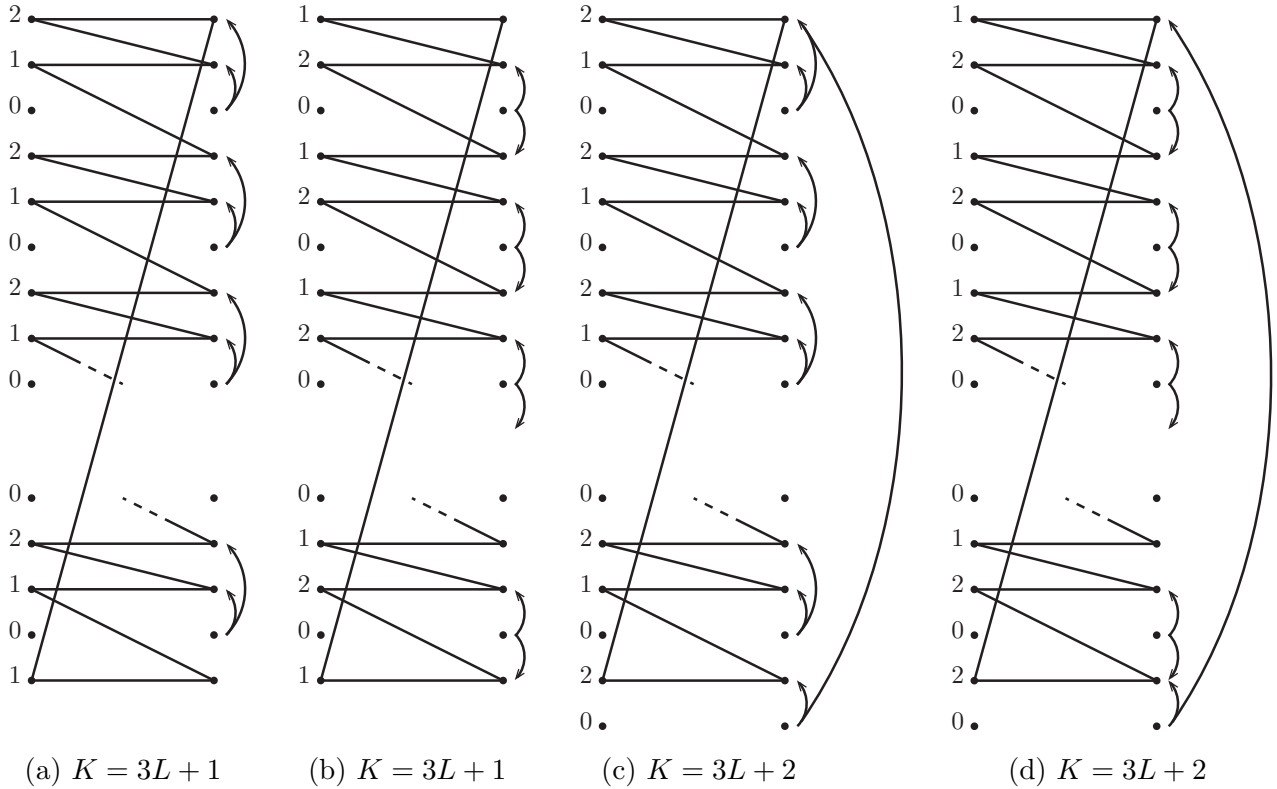

Figure 3.9: Order-2 transmission graph for K -user 3-cyclic SISO IC with $K = 3L + 1$ and $K = 3L + 2$.

versions of graph of Fig. 3.9c together with $L - 2$ times repeating the K cyclically shifted versions of graph of Fig. 3.9d, we can transmit LK order-2 symbols of each type, i.e., a total of $2LK^2$ order-2 symbols. To do so, we spend a total of $4LK$ time slots, and will generate $(L + 2)LK$ symbols of type $u^{[i|i,i+1;i+2]}$ and $(L - 2)(L + 1)K + (L + 2)K = L^2K$ symbols of type $u^{[i|i,i+2;i+1]}$, i.e., a total of $2L(L + 1)K$ symbols of type $u^{[i|i,i+1;i+2]}$ or $u^{[i|i,i+2;i+1]}$. The achieved DoF will be

$$\underline{\text{DoF}}_2^{\text{IC}}(K, 3) = \frac{2LK^2}{4LK + \frac{2L(L+1)K}{\underline{\text{DoF}}_{2;1}^{\text{IC}}(K,3)}} = \frac{K}{2 + \frac{L+1}{\underline{\text{DoF}}_{2;1}^{\text{IC}}(K,3)}}, \quad K = 3L + 2. \quad (3.102)$$

For $L = 1$, i.e., $K = 5$, only the 5 cyclically shifted versions of graph of Fig. 3.9c are used. Hence, 5×5 order-2 symbols are transmitted in 2×5 time slots and 10 side information symbols $u^{[i|i,i+1;i+2]}$ and $u^{[i|i,i+2;i+1]}$, $1 \leq i \leq 5$, are generated. In this way, one

CHAPTER 3: SISO IC AND X CHANNEL WITH DELAYED CSIT

can verify that 3 order-2 symbols of type $u^{[i|i,i+2]}$ and 2 order-2 symbols of type $u^{[i|i,i+1]}$ are transmitted for every $1 \leq i \leq 5$. To maintain the balance between the transmitted order-2 symbols, we need to transmit another symbol of type $u^{[i|i,i+1]}$ for each $1 \leq i \leq 5$. These 5 symbols are transmitted in 3 time slots as follows: In each time slot, TX_i repeats $u^{[i|i,i+1]}$. Thus, after the 3 time slots, each receiver is provided with 3 linearly independent combinations of 3 symbols (two desired and one interference) and can decode all of them. Therefore, the achieved DoF for $K = 5$ will be

$$\underline{\text{DoF}}_2^{\text{IC}}(5, 3) = \frac{25 + 5}{10 + 3 + \frac{10}{\underline{\text{DoF}}_{2;1}^{\text{C}}(5,3)}} = \frac{30}{13 + \frac{10}{\underline{\text{DoF}}_{2;1}^{\text{C}}(5,3)}}. \quad (3.103)$$

Phase 3 (K -user 3-cyclic IC): Each set of K symbols $u^{[i|i,i+1;i+2]}$ (or $u^{[i|i,i+2;i+1]}$), $1 \leq i \leq K$, are delivered in 2 time slots using repetition of each symbol by its corresponding transmitter. Therefore,

$$\underline{\text{DoF}}_{2;1}^{\text{IC}}(K, 3) = \frac{K}{2}. \quad (3.104)$$

Also, each set of K symbols $u^{[i|i+2;i,i+1]}$, $1 \leq i \leq K$, are delivered in 1 time slot by transmission of each symbol by its corresponding transmitter. Therefore,

$$\underline{\text{DoF}}_{1;2}^{\text{IC}}(K, 3) = K. \quad (3.105)$$

The proof is then complete in view of (3.97), (3.99) and (3.101) to (3.105). \square

Figure 3.10 plots our achievable DoF for the K -user 3-cyclic IC with delayed IC, given by Theorem 6, for $3 \leq K \leq 30$, and compares it with the channel DoFs with no CSIT (Theorem 5) and full CSIT.

3.6 Conclusion

We proposed new multiphase interference alignment schemes and obtained new achievable results on the DoF of the Gaussian K -user SISO interference channel and $2 \times K$ SISO X channel under delayed CSIT assumption. Our results show that the DoF of these channels

CHAPTER 3: SISO IC AND X CHANNEL WITH DELAYED CSIT

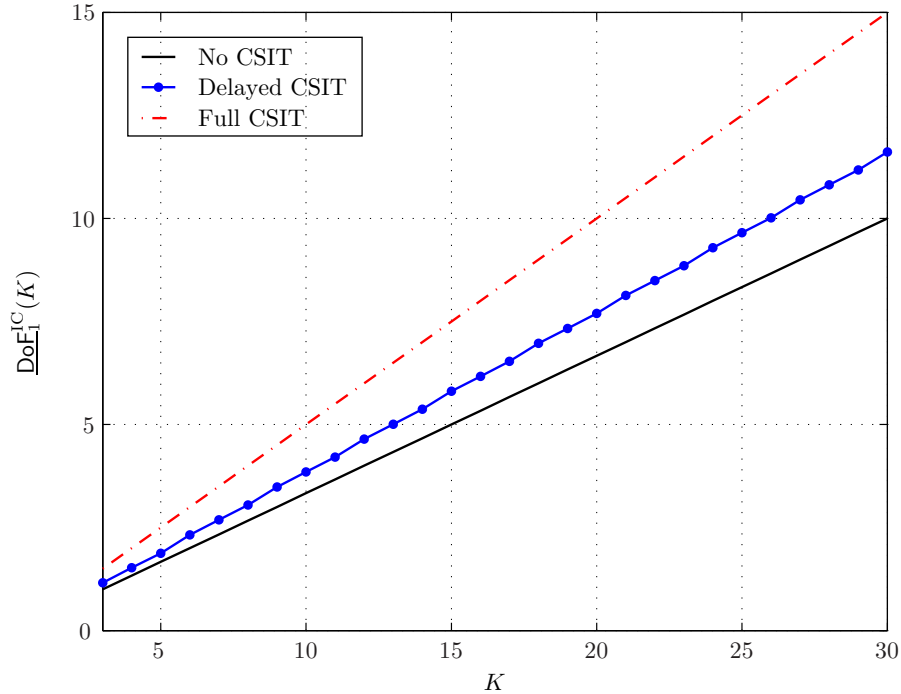

Figure 3.10: The achievable DoF for K -user 3-cyclic IC with delayed CSIT and the channel DoFs with no CSIT and full CSIT.

with the outdated CSI at transmitters is strictly greater than that with no CSIT. The achieved DoFs are strictly increasing in K and approach limiting values of $4/(6 \ln 2 - 1)$ and $1/\ln 2$, respectively, for the interference and X channels as $K \rightarrow \infty$. This is in contrast to the no CSIT assumption wherein it is known that both channels have only one DoF for all values of K . For the interference channel, we improved the best previously known result on the DoF of the 3-user case with delayed CSIT, and to the best of our knowledge, this chapter presents the first and yet the best DoF results for the K -user case with $K > 3$. For the $2 \times K$ X channel, our achievable DoF is strictly greater than the best previously reported result on that of the $K \times K$ X channel. We also generalized our multiphase transmission ideas to the cyclic interference channel. In particular, we showed that the 3-cyclic interference channel with delayed CSIT can achieve a DoF greater than $K/3$, which is its DoF with no CSIT, for all values of $K \geq 3$.

Chapter 4

SISO Interference and X Channels with Full-Duplex Transmitter Cooperation and Feedback

In this chapter¹, we address the K -user SISO IC and $M \times K$ SISO X channel with no *instantaneous* CSIT, and study the impact of full-duplex transmitter cooperation and/or different types of feedback on DoF of these channels. We present the system model in Section 4.1. Then, we give some illustrative examples of transmission over the interference channel in Section 4.2 and X channel in Section 4.3. These examples exploit the feedback/transmitter cooperation models defined in Section 4.1 and highlight our transmission ideas for these channels with a few number of users. Then, we present our main results in Section 4.4, and provide the proofs in subsequent sections. In particular, we consider these channels with delayed CSIT and full-duplex transmitter cooperation in Section 4.5. Regarding the full-duplex CSI, we assume that the source nodes (transmitters) have only access to their incoming full-duplex CSI. We propose transmission schemes that achieve DoF values greater than the best available achievable DoFs for these channels with delayed CSIT but without transmitter cooperation (cf. Chapter 3).

In Section 4.6, we consider the same channels with output feedback, wherein we assume

¹The work in this chapter has been reported in [4, 5]

that each transmitter has a causal access to the output of its paired receiver through a feedback link. This is indeed a limited output feedback (in contrast to providing each transmitter with the outputs of more than one receiver), however, the term “limited” will be henceforth dropped for brevity. Therefore, in the X channel, we hereafter consider only $M = K$ with a one-to-one mapping between transmitters and receivers for feedback assignment. The 3-user IC and 2×2 X channel with output feedback were previously investigated in [35], wherein $6/5$ and $4/3$ DoF were respectively achieved. While achieving the same DoFs for the 3-user IC and 2×2 X channel, our main contribution here is proposing multi-phase transmission schemes for the general K -user cases that achieve DoF values strictly increasing in K .

Next, we study the K -user SISO IC and $K \times K$ SISO X channel with delayed CSIT *and* output feedback in Section 4.7. Under this assumption, which is referred to as *Shannon feedback*, we propose multi-phase transmission schemes capturing both the delayed CSI and output feedback to cooperatively transmit over the channel. The achieved DoFs are strictly increasing in K and greater than those we achieved with output feedback for $K = 5$ and $K > 6$ in the K -user IC and for $K > 2$ in the $K \times K$ X channel. The achievable results will be compared and discussed in Section 4.8, and finally, the chapter is concluded in Section 4.9.

4.1 System Model

Consider the K -user SISO Gaussian IC and $M \times K$ X channel as defined in Section 3.1. The delayed CSIT model was defined in Section 3.1 for these channel. In this chapter, we first assume that the transmitters, in addition to having delayed CSI, are able to operate in full-duplex mode, which is defined as follows:

Definition 8 (Full-duplex Transmitter Cooperation). *The transmitters are said to operate in full-duplex mode if they can transmit and receive simultaneously. In full-duplex mode, the received signal of TX_i in time slot t is given by*

$$K\text{-user IC : } \tilde{y}^{[i]}(t) = \sum_{i'=1}^K \tilde{h}^{[ii']}(t)x^{[i']}(t) + \tilde{z}^{[i]}(t), \quad 1 \leq i \leq K. \quad (4.1)$$

CHAPTER 4: FULL-DUPLEX TX COOPERATION AND FEEDBACK

$$M \times K \text{ X channel : } \quad \tilde{y}^{[i]}(t) = \sum_{i'=1}^M \tilde{h}^{[ii']}(t)x^{[i']}(t) + \tilde{z}^{[i]}(t), \quad 1 \leq i \leq M. \quad (4.2)$$

The noise terms and channel coefficients are assumed to be drawn according to $\mathcal{CN}(0, 1)$ and i.i.d. across all nodes as well as time. No feedback link is available between the transmitters, and hence, TX_i is assumed to have only its incoming full-duplex channel coefficients, i.e., $\{\tilde{h}^{[ii']}(t)\}_{i'=1}^K$ in the IC and $\{\tilde{h}^{[ii']}(t)\}_{i'=1}^M$ in the X channel, perfectly and instantaneously.

Moreover, we consider two different feedback models as follows:

Definition 9 (Feedback Models). *We assume that each receiver knows channel coefficients of the other receivers with one time slot delay. Also,*

- **Output Feedback:** *Each channel output $y^{[i]}(t)$, $1 \leq i \leq K$, will become available at TX_i with one time slot delay via a noiseless feedback link. Therefore, for the X channel, we only consider $M = K$ under the output feedback assumption.*
- **Shannon Feedback:** *The transmitters have access to both delayed CSIT and output feedback as defined above. Therefore, for the X channel, we only consider $M = K$ under the Shannon feedback assumption.*

Definition 10 (Transmitter Side Information). *Using Definitions 8 and 9, the following feedback and/or transmitter cooperation models will be investigated in this chapter, each of which is equivalent to a certain transmitter side information:*

(a) *The K-user IC and $M \times K$ X channel with delayed CSIT and full-duplex transmitter cooperation:*

K-user IC:

$$\mathcal{I}^{[i]}(t) \triangleq \{\tilde{y}^{[i]}(t'), \mathbf{H}(t')\}_{t'=1}^{t-1} \cup \{\tilde{h}^{[ii']}(t') : 1 \leq i' \leq K\}_{t'=1}^t, \quad 1 \leq i \leq K. \quad (4.3)$$

$M \times K$ X channel:

$$\mathcal{I}^{[i]}(t) \triangleq \{\tilde{y}^{[i]}(t'), \mathbf{H}(t')\}_{t'=1}^{t-1} \cup \{\tilde{h}^{[ii']}(t') : 1 \leq i' \leq M\}_{t'=1}^t, \quad 1 \leq i \leq M. \quad (4.4)$$

(b) The K -user IC and $K \times K$ X channel with output feedback:

$$\mathcal{I}^{[i]}(t) \triangleq \{y^{[i]}(t')\}_{t'=1}^{t-1}, \quad 1 \leq i \leq K. \quad (4.5)$$

(c) The K -user IC and $K \times K$ X channel with Shannon feedback:

$$\mathcal{I}^{[i]}(t) \triangleq \{y^{[i]}(t'), \mathbf{H}(t')\}_{t'=1}^{t-1}, \quad 1 \leq i \leq K. \quad (4.6)$$

For the definitions of block codes and DoF, the reader is referred to Definitions 6 and 7.

In the following two sections, we elaborate on our transmission schemes for examples of the IC with a few number of users. Each channel will be investigated under each of the following assumptions defined in Definition 10:

- (a) Full-duplex transmitter cooperation and delayed CSIT (which is also called *full-duplex delayed CSIT* in this chapter);
- (b) Output feedback;
- (c) Shannon feedback.

4.2 Illustrative Examples: Interference Channel

Note that for the two-user IC, none of the assumptions (a)-(c) can help to achieve more than one DoF. This follows from the fact that DoF of this channel with full CSIT is equal to 1, and full-duplex cooperation and/or output feedback cannot increase the channel DoF with full CSIT[11]. Hence, we start by the 3-user IC and present our transmission scheme under each of the assumptions (a)-(c). Subsequently, we consider the 4-user IC to illustrate how our transmission techniques are generalized to the IC with more users. Let us introduce some notations which will be used *only* in this section and Section 4.3:

Notation 4. *In the IC, we denote fresh information symbols of TX_1 , TX_2 , TX_3 , and TX_4 (intended for their paired receivers) by u , v , w , and s variables, respectively. Each of these symbols is selected from a Gaussian codeword which is intended to be decoded at its corresponding receiver.*

Notation 5. *The transmission schemes are multiphase. A linear combination of transmitted symbols which is received by RX_1 is denoted by $L_a(\cdot)$ if we are in phase 1 of the scheme, and by $L'_a(\cdot)$ or $L'_{a,t}(\cdot)$ if we are in phase 2, where t is the time index. Similarly, $L_b(\cdot)$, $L_c(\cdot)$, and $L_d(\cdot)$ and their primed versions denote the linear combinations available at RX_2 , RX_3 , and RX_4 , respectively. A linear combination which is available at a receiver but is not desired by that receiver is coloured by a colour specified to that receiver. In particular, “blue”, “red”, “green”, and “yellow” are assigned to RX_1 to RX_4 , respectively.*

4.2.1 3-user Interference Channel

The schemes we propose for the 3-user IC under the assumptions (a)-(c) are motivated by the scheme proposed in [35] for the 3-user IC with output feedback, i.e., assumption (b). Indeed, the scheme proposed here for the 3-user IC with output feedback is a modified version of the scheme proposed in [35] and achieves the same DoF of 6/5. The modification is such that our scheme can be systematically generalized to larger networks. For the full-duplex delayed CSIT and Shannon feedback, our transmission schemes also achieve 6/5 DoF. Each scheme operates in 2 distinct phases. Since phase 1 is the same for all three schemes, we present phase 1 only once, and then present phase 2 under each assumption separately.

Phase 1 (3-user IC):

This phase takes 3 time slots, during which 6 information symbols $\{u_1, u_2\}$, $\{v_1, v_2\}$, and $\{w_1, w_2\}$ are fed to the system respectively by TX_1 , TX_2 , and TX_3 as follows:

▷ *First time slot:* TX_1 and TX_2 transmit u_1 and v_1 , respectively, while TX_3 is silent. Hence, ignoring the noise, RX_1 and RX_2 each receive one linear equation in terms of u_1 and v_1 by the end of the first time slot as follows:

$$RX_1 : \quad L_a(u_1, v_1) = h^{[11]}(1)u_1 + h^{[12]}(1)v_1, \quad (4.7)$$

$$RX_2 : \quad L_b(u_1, v_1) = h^{[21]}(1)u_1 + h^{[22]}(1)v_1. \quad (4.8)$$

Therefore, if we deliver another linearly independent combination of u_1 and v_1 to RX_1 , it will be able to decode both transmitted symbols (the desired symbol u_1 and the interference

CHAPTER 4: FULL-DUPLEX TX COOPERATION AND FEEDBACK

symbol v_1). Similarly, if we deliver a linearly independent combination of u_1 and v_1 to RX_2 , it can decode both u_1 which is interference and v_1 which is a desired symbol.

Now, we observe that RX_3 has also received a linear combination of u_1 and v_1 , i.e., ignoring the noise,

$$\text{RX}_3 : \quad L_c(u_1, v_1) = h^{[31]}(1)u_1 + h^{[32]}(1)v_1. \quad (4.9)$$

Note first that this quantity does not contain any information about the information symbols of RX_3 (w symbols). Therefore, it is *not* desired by RX_3 . However, since the channel coefficients are i.i.d. across the nodes, $L_c(u_1, v_1)$ is linearly independent of each of $L_a(u_1, v_1)$ and $L_b(u_1, v_1)$ almost surely. Therefore, if we somehow deliver $L_c(u_1, v_1)$ to both RX_1 and RX_2 , each of them will be able to decode its own desired symbol (together with the interference symbol). Hence, $L_c(u_1, v_1)$ is a new “symbol” which is simultaneously desired by both RX_1 and RX_2 and is available at RX_3 .

Transmission in the second and third time slots is done similar to the first time slot, except that roles of the nodes are exchanged:

▷ *Second time slot:* TX_2 and TX_3 transmit v_2 and w_1 , respectively, while TX_1 is silent. After this time slot, the linear combination $L_a(v_2, w_1)$ will be desired by both RX_2 and RX_3 .

▷ *Third time slot:* TX_3 and TX_1 transmit w_2 and u_2 , respectively, while TX_2 is silent. After this time slot, $L_b(u_2, w_2)$ will be desired by both RX_3 and RX_1 .

The transmission in phase 1 is visually illustrated in Fig. 4.1. Note in the figure that in each time slot, the coloured quantity denotes the quantity which is available and undesired at the corresponding receiver by the end of that time slot. It only remains to deliver these coloured symbols, i.e., $L_c(u_1, v_1)$, $L_a(v_2, w_1)$, and $L_b(u_2, w_2)$ to the pairs of receivers where they are desired as discussed above. This will be accomplished in phase 2 through cooperation between the transmitters. The type of cooperation is determined by the channel feedback/cooperation assumption, that is, the assumptions (a)-(c). However, under each assumption, phase 2 takes 2 time slots, and thus, the overall achieved DoF will be $6/5$. In the following, we present the phase 2 under each assumption separately:

Phase 2 (Full-duplex 3-user IC with Delayed CSIT):

Recall that in the first time slot, TX₁ and TX₂ respectively transmitted u_1 and v_1 , and TX₃ was silent. According to full-duplex operation of the transmitters, TX₁ receives a noisy version of v_1 and TX₂ receives a noisy version of u_1 by the end of this time slot. This along with the delayed CSIT assumption enables both TX₁ and TX₂ to reconstruct a noisy version of $L_c(u_1, v_1)$, whose noise can be ignored as mentioned in previous chapters. Similarly, both TX₂ and TX₃ will reconstruct $L_a(v_2, w_1)$ after the second time slot, and both TX₃ and TX₁ will reconstruct $L_b(u_2, w_2)$ after the third time slot. Therefore, this phase takes 2 time slots as follows:

▷ *Fourth time slot:* The symbols $L_c(u_1, v_1)$, $L_a(v_2, w_1)$, and $L_b(u_2, w_2)$ are transmitted by TX₁, TX₂, and TX₃, respectively. Then, RX₁ receives the following linear combination

$$L'_{a,4}(L_a(v_2, w_1), L_b(u_2, w_2), L_c(u_1, v_1)) = h^{[11]}(4)L_c(u_1, v_1) + h^{[12]}(4)L_a(v_2, w_1) + h^{[13]}(4)L_b(u_2, w_2),$$

and since it already has the undesired quantity $L_a(v_2, w_1)$, it can cancel it to obtain an equation solely in terms of $L_c(u_1, v_1)$ and $L_b(u_2, w_2)$. Remember that both $L_c(u_1, v_1)$ and $L_b(u_2, w_2)$ are going to be delivered to RX₁.

Also, RX₂ receives

$$L'_{b,4}(L_a(v_2, w_1), L_b(u_2, w_2), L_c(u_1, v_1)) = h^{[21]}(4)L_c(u_1, v_1) + h^{[22]}(4)L_a(v_2, w_1) + h^{[23]}(4)L_b(u_2, w_2),$$

and RX₃ receives

$$L'_{c,4}(L_a(v_2, w_1), L_b(u_2, w_2), L_c(u_1, v_1)) = h^{[31]}(4)L_c(u_1, v_1) + h^{[32]}(4)L_a(v_2, w_1) + h^{[33]}(4)L_b(u_2, w_2)$$

by the end of the fourth time slot. Similarly, RX₂, having the undesired quantity $L_b(u_2, w_2)$, will obtain an equation in terms of two desired quantities $L_a(v_2, w_1)$ and $L_c(u_1, v_1)$. Also, RX₃ will similarly obtain an equation solely in terms of $L_a(v_2, w_1)$ and $L_b(u_2, w_2)$.

CHAPTER 4: FULL-DUPLEX TX COOPERATION AND FEEDBACK

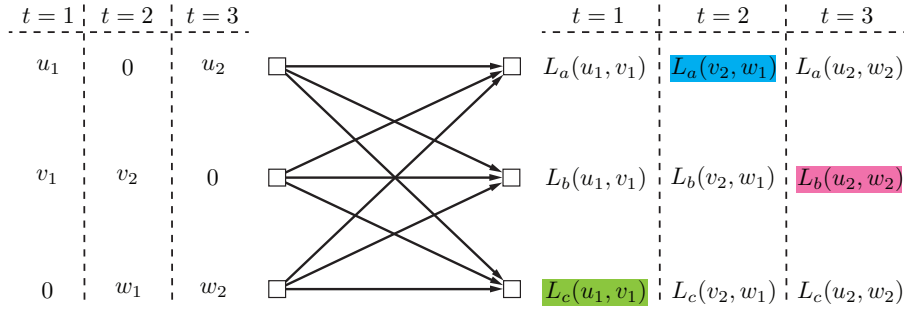

Figure 4.1: Phase 1 of the transmission scheme for 3-user IC. Each coloured linear combination is the one which is (i) available at a receiver, (ii) not desired by that receiver, and (iii) desired by the other receivers.

▷ *Fifth time slot*: This time slot is an exact repetition of the fourth time slot. Hence, since the channel coefficients are i.i.d. in time, by the end of this time slot, each receiver obtains a linearly independent equation in terms of its own two desired quantities, and thus, can decode both desired quantities.

The above transmission scheme in phase 2 is illustrated in Fig. 4.2a. This completes the delivery of the 6 information symbols $\{u_1, u_2, v_1, v_2, w_1, w_2\}$ to their intended receivers in 5 time slots, and thus, proves achievability of $6/5$ DoF with full-duplex delayed CSIT.

Phase 2 (3-user IC with Output Feedback):

With access to output feedback, the quantity $L_c(u_1, v_1)$ is available at TX₃ after the first time slot. Similarly, $L_a(v_2, w_1)$ and $L_b(u_2, w_2)$ are available at TX₁ and TX₂, respectively, after the second and third time slots. Hence, transmission of these symbols in phase 2 can be done in two time slots using the same scheme explained above. The only difference is that here $L_a(v_2, w_1)$, $L_b(u_2, w_2)$, and $L_c(u_1, v_1)$ are transmitted by TX₁, TX₂, and TX₃ respectively, as shown in Fig. 4.2b.

Phase 2 (3-user IC with Shannon Feedback):

Under the Shannon feedback assumption, we argue that $L_c(u_1, v_1)$ is available at all three transmitters after the first time slot as follows: TX₃ obtains $L_c(u_1, v_1)$ through the output feedback. On the other hand, TX₁, having access to output feedback, obtains

CHAPTER 4: FULL-DUPLEX TX COOPERATION AND FEEDBACK

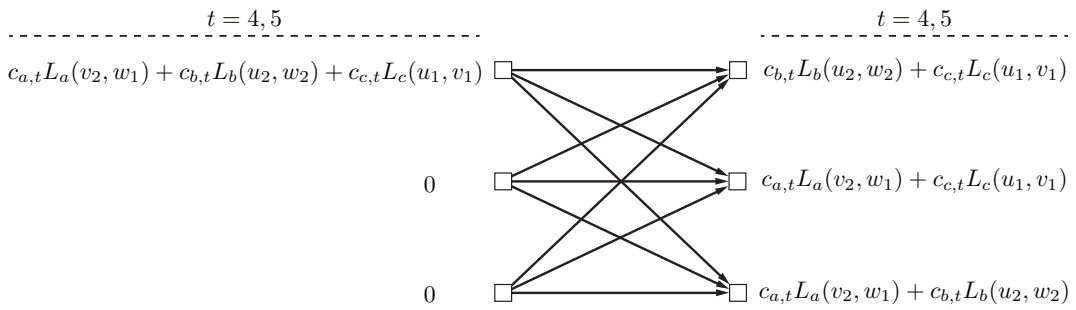
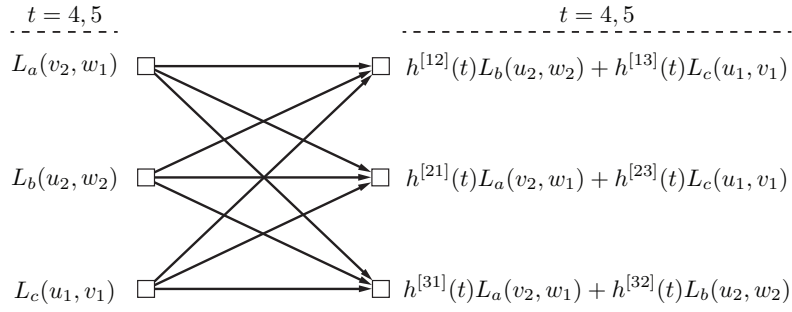
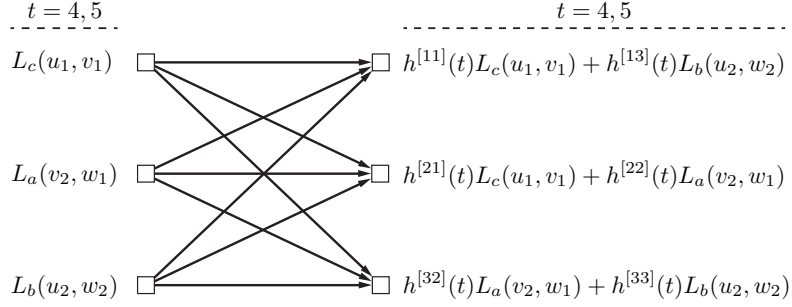

Figure 4.2: Phase 2 of the transmission scheme for 3-user IC.

CHAPTER 4: FULL-DUPLEX TX COOPERATION AND FEEDBACK

$L_a(u_1, v_1)$ after this time slot. Then, since it also has access to delayed CSI and its own transmitted symbol u_1 , it can cancel the effect of u_1 from $L_a(u_1, v_1)$ to obtain v_1 . Therefore, it can reconstruct $L_c(u_1, v_1)$ using u_1 , v_1 , and the delayed CSI. Similarly, TX₂ can reconstruct $L_c(u_1, v_1)$. Using a similar argument, $L_a(v_2, w_1)$ and $L_b(u_2, w_2)$ will be available at all three transmitters after the second and third time slots, respectively.

Recall that under each of the assumptions of full-duplex delayed CSIT and output feedback, to deliver $L_a(v_2, w_1)$, $L_b(u_2, w_2)$, and $L_c(u_1, v_1)$ to their intended pairs of receiver in phase 2, we delivered two random linear combinations of them to each receiver. In those cases, each of these symbols was repeated by one of the transmitters in two time slots simultaneously. Here, we again deliver two random linear combinations of these three symbols to each receiver using another approach: two random linear combinations of $L_a(v_2, w_1)$, $L_b(u_2, w_2)$, and $L_c(u_1, v_1)$ are transmitted by one of the transmitters, say TX₁, in two time slots $t = 4, 5$, while the rest of transmitters are silent. The coefficients of these combinations are generated *offline* and revealed to all receivers before the transmission begins. Hence, after two time slots, each receiver obtains two random linear combinations in terms of $L_a(v_2, w_1)$, $L_b(u_2, w_2)$, and $L_c(u_1, v_1)$, and will be able to remove its known undesired quantity and decode the other two desired quantities. Therefore, 6/5 DoF is also achieved with Shannon feedback. The phase 2 of the transmission scheme with Shannon feedback is depicted in Fig. 4.2c, where $\{c_{a,t}, c_{b,t}, c_{c,t} | t = 1, 2\}$ are the random coefficient.

4.2.2 4-user Interference Channel

Before proceeding with the 4-user IC, let us summarize the common ingredients of the transmission schemes proposed for the 3-user IC as follows:

- (i) The transmission is accomplished in consecutive phases (two phases in case of the 3-user IC).
- (ii) In each time slot of phase 1, fresh information symbols are transmitted by a subset \mathcal{S} of transmitters (with $|\mathcal{S}| = 2$ in case of the 3-user IC). The set of all receivers is then partitioned into two subsets \mathcal{S} and its complement \mathcal{S}^c (with $|\mathcal{S}^c| = 1$ in case

CHAPTER 4: FULL-DUPLEX TX COOPERATION AND FEEDBACK

of the 3-user IC). Each receiver in \mathcal{S} has a desired information symbol among the transmitted symbols, whereas the receivers in \mathcal{S}^c are not interested in decoding any transmitted symbol in this time slot.

- (iii) Each receiver in \mathcal{S} receives a piece of information (linear equation) in terms of its own desired symbol and $|\mathcal{S}| - 1$ interference symbol(s). Since there are more than one unknowns in the received equation, the receiver cannot resolve the equation for its desired symbol. It requires another $|\mathcal{S}| - 1$ linearly independent equations to resolve its own desired symbol (*and* the interference symbols).
- (iv) Each receiver in \mathcal{S}^c receives a piece of information (linear equation) in terms of $|\mathcal{S}|$ undesired (interference) symbols. The linear equations received by any arbitrary $|\mathcal{S}| - 1$ receivers out of these $|\mathcal{S}^c|$ receivers are, however, desired by all receivers in \mathcal{S} , in view of observation (iii) and the fact of the channel coefficients are i.i.d. across the channel nodes.
- (v) Let RX_{j^*} be one of these $|\mathcal{S}| - 1$ receivers. The linear combination received by RX_{j^*} , if retransmitted, provides each receiver in \mathcal{S} with a desired equation without causing any further interference at RX_{j^*} . In this sense, this linear combination can be considered as an “aligned interference” at RX_{j^*} because it only occupies one dimension in the received equation space of RX_{j^*} .
- (vi) These $|\mathcal{S}| - 1$ pieces of information are also available at a “subset of transmitters”, depending on the channel feedback/cooperation assumption. These transmitters can cooperate to retransmit these $|\mathcal{S}| - 1$ pieces of information in the subsequent phases of the transmission scheme (phase 2 in case of the 3-user IC).

Along the direction highlighted by the above observations, we propose a 3-phase transmission scheme for the 4-user IC under each of the assumptions (a)-(c). As in the 3-user case, the proposed schemes for the 4-user IC have the same performance in terms of achievable DoF and achieve 24/19 DoF under each assumption. We note that this is strictly greater than 45/38 DoF which is the best known achievable DoF for the 4-user IC with delayed CSIT [1]. Since the three schemes are common in their phase 1, we present phase 1 only once and then present the remaining phases separately under each assumption:

CHAPTER 4: FULL-DUPLEX TX COOPERATION AND FEEDBACK

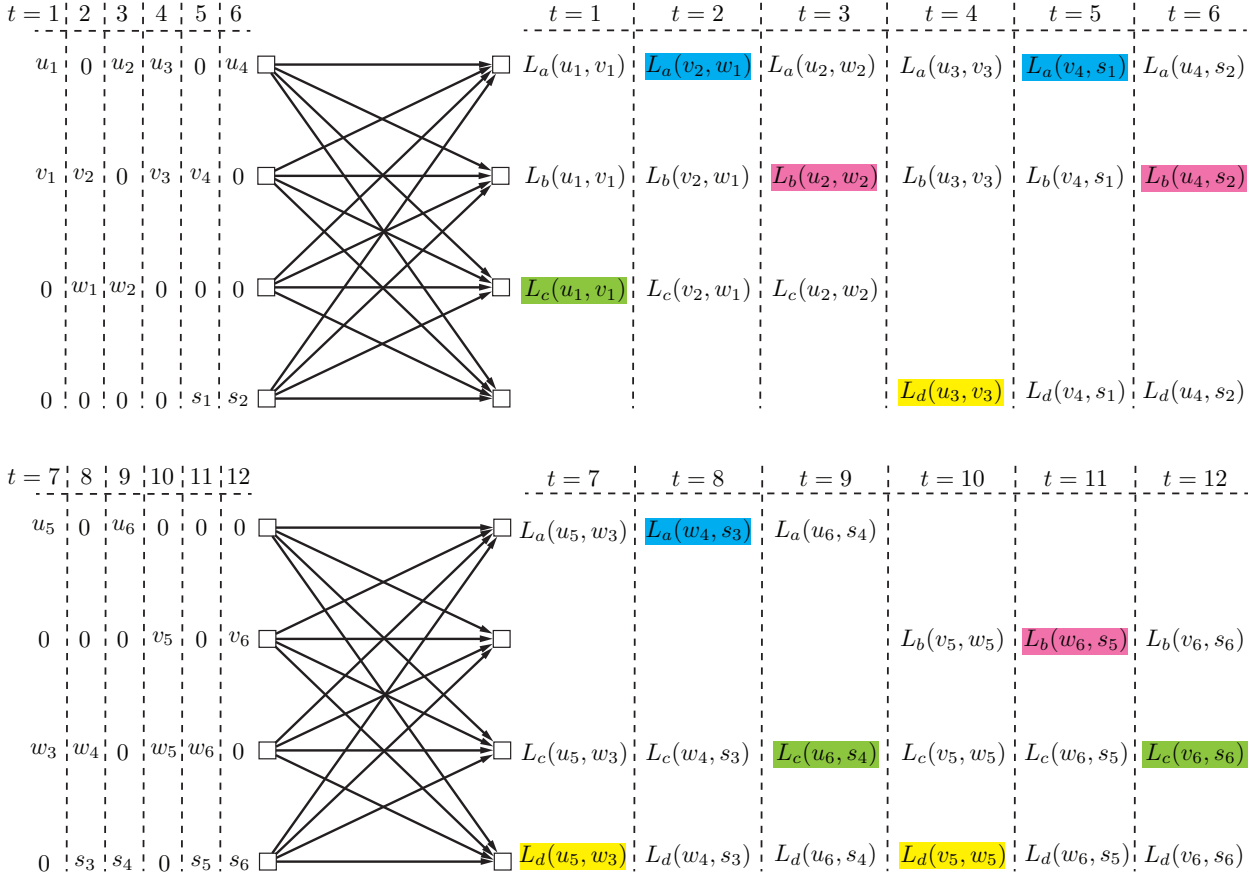

Figure 4.3: Phase 1 of the transmission scheme for 4-user IC. Each coloured linear combination is the one which is (i) available at a receiver, (ii) not desired by that receiver, and (iii) desired by two of the other receivers.

Phase 1 (4-user IC):

This phase takes 12 time slots, during which 24 information symbols

$$\{u_i, v_i, w_i, s_i | i = 1, \dots, 6\} \quad (4.10)$$

are fed to the system by the transmitters in parallel with phase 1 of the scheme for the 3-user IC (see Section 4.2.1). Figure 4.3 illustrates the transmission in phase 1 for the 4-user IC.

CHAPTER 4: FULL-DUPLEX TX COOPERATION AND FEEDBACK

▷ *Time slots $t = 1, \dots, 3$:* TX₁, TX₂, and TX₃ transmit 6 information symbols $\{u_1, u_2, v_1, v_2, w_1, w_2\}$ exactly as in the 3-user case. TX₄ is silent during the first 3 time slots. Consequently, the linear combinations $L_a(v_2, w_1)$, $L_b(u_2, w_2)$, and $L_c(u_1, v_1)$ which are respectively received by RX₁, RX₂, and RX₃ need to be delivered to their respective pairs of receivers during the remaining phases. The availability of these quantities at TX₁, TX₂ and TX₂ after the first 3 time slots depends on the channel feedback/cooperation assumption and can be summarized as follows (see the corresponding phase 2 in Section 4.2.1 for a detailed discussion):

- *Full-duplex delayed CSIT:* $L_a(v_2, w_1)$ is available at TX₂ and TX₃; $L_b(u_2, w_2)$ is available at TX₁ and TX₃; and $L_c(u_1, v_1)$ is available at TX₁ and TX₂.
- *Output feedback:* $L_a(v_2, w_1)$, $L_b(u_2, w_2)$, and $L_c(u_1, v_1)$ are available at TX₁, TX₂, and TX₃, respectively.
- *Shannon feedback:* $L_a(v_2, w_1)$, $L_b(u_2, w_2)$, and $L_c(u_1, v_1)$ are available at all three transmitters TX₁, TX₂, and TX₃.

The transmission in the remaining time slots of this phase is similarly proceeded by different subsets of 3 out of the 4 transmitters:

▷ *Time slots $t = 4, \dots, 6$:* TX₁, TX₂, and TX₄ transmit fresh information symbols $\{u_3, u_4, v_3, v_4, s_1, s_2\}$, while TX₃ is silent. Similarly, $L_a(v_4, s_1)$, $L_b(u_4, s_2)$, and $L_d(u_3, v_3)$ which are respectively received by RX₁, RX₂, and RX₄ need to be delivered to their respective pairs of receivers during the remaining phases. These quantities are similarly available at subsets of $\{TX_1, TX_2, TX_4\}$ based on the channel feedback/cooperation assumption.

▷ *Time slots $t = 7, \dots, 9$:* TX₁, TX₃, and TX₄ transmit fresh information symbols $\{u_5, u_6, w_3, w_4, s_3, s_4\}$, while TX₂ is silent. Similarly, $L_a(w_4, s_3)$, $L_c(u_6, s_4)$, and $L_d(u_5, w_3)$ which are respectively received by RX₁, RX₃, and RX₄ need to be delivered to their respective pairs of receivers during the remaining phases. These quantities are similarly available at subsets of $\{TX_1, TX_3, TX_4\}$ based on the channel feedback/cooperation assumption.

▷ *Time slots $t = 10, \dots, 12$:* TX₂, TX₃, and TX₄ transmit fresh information symbols $\{v_5, v_6, w_5, w_6, s_5, s_6\}$, while TX₁ is silent. Similarly, $L_b(w_6, s_5)$, $L_c(v_6, s_6)$, and $L_d(v_5, w_5)$

CHAPTER 4: FULL-DUPLEX TX COOPERATION AND FEEDBACK

which are respectively received by RX₂, RX₃, and RX₄ need to be delivered to their respective pairs of receivers during the remaining phases. These quantities are similarly available at subsets of {TX₂, TX₃, TX₄} based on the channel feedback/cooperation assumption.

Now, let us proceed with the remaining phases under each of the channel feedback/cooperation assumptions (a)-(c):

Full-duplex 4-user IC with Delayed CSIT

Phase 2 (Full-duplex 4-user IC with Delayed CSIT):

This phase takes 4 time slots. In each time slot, 3 transmitters simultaneously transmit three symbols generated during phase 1 as follows:

▷ *Time slot $t = 13$* : TX₁, TX₂, and TX₃ respectively transmit $L_c(u_1, v_1)$, $L_a(v_2, w_1)$, and $L_b(u_2, w_2)$, while TX₄ is silent. RX₁ has $L_a(v_2, w_1)$ and wishes to decode $L_b(u_2, w_2)$ and $L_c(u_1, v_1)$. Hence, RX₁ can obtain a linear combination solely in terms of $L_b(u_2, w_2)$ and $L_c(u_1, v_1)$ by cancelling $L_a(v_2, w_1)$ from its received equation. Similarly, RX₂ and RX₃ each obtain a linear combination in terms of their desired pair of quantities. Thus, each of RX₁, RX₂, and RX₃ requires another linearly independent equation to resolve its both desired quantities.

Now, consider the following linear combination received by RX₄ over this time slot:

$$L'_d(L_a(v_2, w_1), L_b(u_2, w_2), L_c(u_1, v_1)) = \\ h^{[41]}(13)L_c(u_1, v_1) + h^{[42]}(13)L_a(v_2, w_1) + h^{[43]}(13)L_b(u_2, w_2).$$

If we somehow deliver the above linear combination to RX₁, it can obtain $h^{[41]}(13)L_c(u_1, v_1) + h^{[43]}(13)L_b(u_2, w_2)$ by cancelling $L_a(v_2, w_1)$. Since the channel coefficients are i.i.d. across the channel nodes, this linear combination is linearly independent of the equation RX₁ has received during this time slot, and hence, it will enable RX₁ to resolve its both desired quantities. Likewise, if we deliver $L'_d(L_a(v_2, w_1), L_b(u_2, w_2), L_c(u_1, v_1))$ to RX₂ and RX₃, each of them will be able to decode its both desired quantities. Thus, it is desired by RX₁, RX₂, and RX₃, and will be delivered to them in phase 3.

CHAPTER 4: FULL-DUPLEX TX COOPERATION AND FEEDBACK

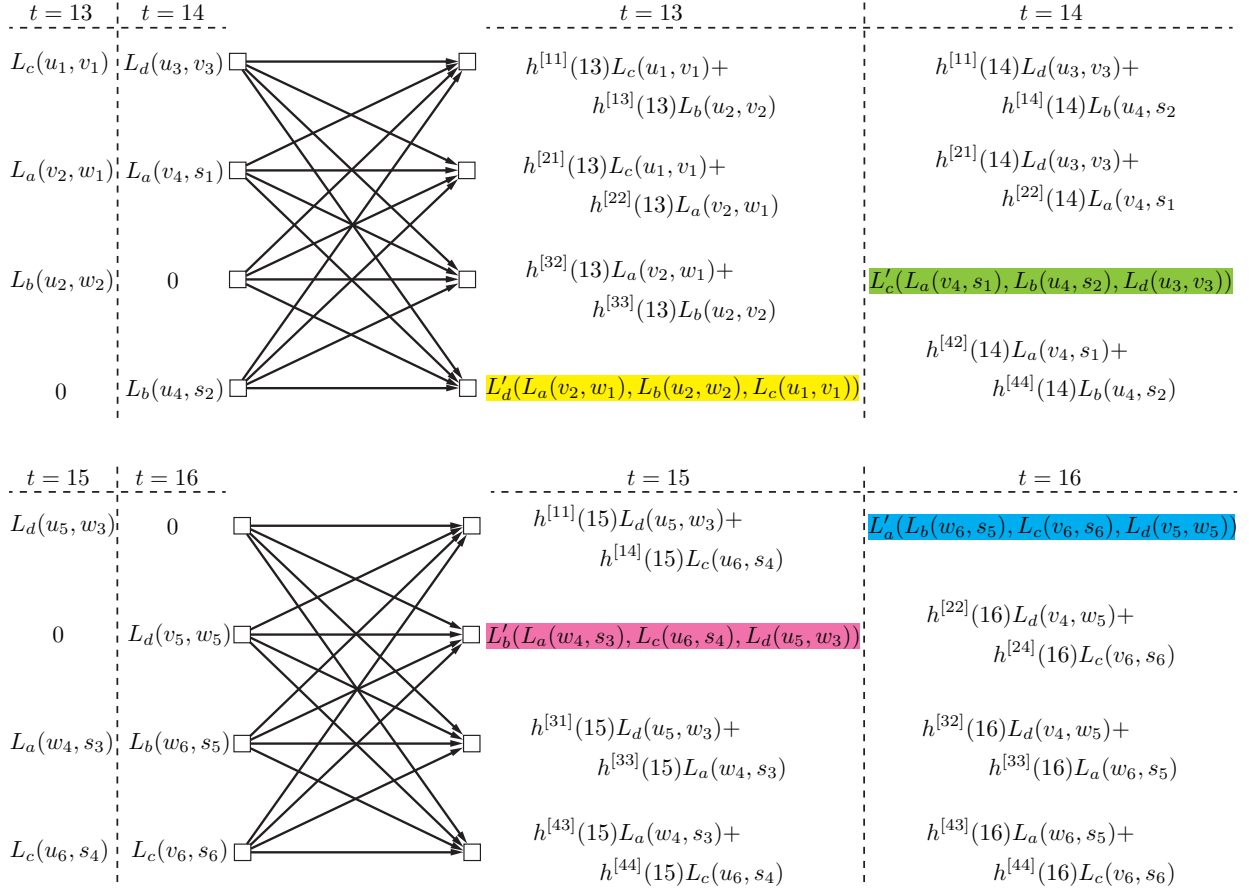

Figure 4.4: Phase 2 of the transmission scheme for full-duplex 4-user IC with delayed CSIT. Each coloured linear combination is the one which is (i) available at a receiver, (ii) not desired by that receiver, and (iii) desired by the other receivers.

We now argue that this linear combination will be available at TX₁, TX₂ and TX₃ after this time slot. We indeed show that $L_c(u_1, v_1)$, $L_a(v_2, w_1)$, and $L_b(u_2, w_2)$ will be available at these three transmitters, which together with the delayed CSIT assumption yields the desired result. But this immediately follows from the fact that each of TX₁, TX₂, and TX₃ has two out of these three quantities, and thus, by the full-duplex operation, receives the third one during this time slot.

The transmission in the remaining 3 time slots of phase 2 is similarly done by other subsets of 3 out of the 4 transmitters:

CHAPTER 4: FULL-DUPLEX TX COOPERATION AND FEEDBACK

▷ *Time slot $t = 14$* : TX₁, TX₂, and TX₄ respectively transmit $L_d(u_3, v_3)$, $L_a(v_4, s_1)$, and $L_b(u_4, s_2)$ and the following linear combination which is received by RX₃ will be desired by RX₁, RX₂, and RX₄ and available at TX₁, TX₂, and TX₄:

$$L'_c(L_a(v_4, s_1), L_b(u_4, s_2), L_d(u_3, v_3)) = h^{[31]}(14)L_d(u_3, v_3) + h^{[32]}(14)L_a(v_4, s_1) + h^{[34]}(14)L_b(u_4, s_2).$$

▷ *Time slot $t = 15$* : TX₁, TX₃, and TX₄ respectively transmit $L_d(u_5, w_3)$, $L_a(w_4, s_3)$, and $L_c(u_6, s_4)$ and the following linear combination which is received by RX₂ will be desired by RX₁, RX₃, and RX₄ and available at TX₁, TX₃, and TX₄:

$$L'_b(L_a(w_4, s_3), L_c(u_6, s_4), L_d(u_5, w_3)) = h^{[21]}(15)L_d(u_5, w_3) + h^{[23]}(15)L_a(w_4, s_3) + h^{[24]}(15)L_c(u_6, s_4).$$

▷ *Time slot $t = 16$* : TX₂, TX₃, and TX₄ respectively transmit $L_d(v_5, w_5)$, $L_b(w_6, s_5)$, and $L_c(v_6, s_6)$ and the following linear combination which is received by RX₁ will be desired by RX₂, RX₃, and RX₄ and available at TX₂, TX₃, and TX₄:

$$L'_a(L_b(w_6, s_5), L_c(v_6, s_6), L_d(v_5, w_5)) = h^{[12]}(16)L_d(v_5, w_5) + h^{[13]}(16)L_b(w_6, s_5) + h^{[14]}(16)L_c(v_6, s_6).$$

Figure 4.4 illustrates the transmission in phase 2 for the 4-user IC with full-duplex delayed CSIT. The symbols L'_a , L'_b , L'_c , and L'_d will be delivered to their respective triples of receivers in phase 3.

Phase 3 (Full-duplex 4-user IC with Delayed CSIT):

This phase takes 3 time slots. In each time slot, L'_d , L'_c , L'_b , and L'_a are transmitted by TX₁, TX₂, TX₃, and TX₄, respectively. Each receiver has one of these quantities and requires the other three. By the end of this phase, each receiver will obtain three random linear combinations of its three desired quantities, and thus, will decode its desired quantities.

4-user IC with Output Feedback

Phase 2 (4-user IC with Output Feedback):

The above scheme for the phase 2 under full-duplex delayed CSIT assumption can be used under output feedback assumption as well. The only difference is that in each of the 4 time slots, the three corresponding symbols are transmitted using a different permutation of the same transmitters as follows:

▷ *Time slot $t = 13$:* TX₁, TX₂, and TX₃ respectively transmit $L_a(v_2, w_1)$, $L_b(u_2, w_2)$, and $L_c(u_1, v_1)$, while TX₄ is silent. The linear combination $L'_d(L_a(v_2, w_1), L_b(u_2, w_2), L_c(u_1, v_1))$ will then be desired by RX₁, RX₂, and RX₃ and will be available at TX₄ after this time slot via output feedback.

▷ *Time slot $t = 14$:* TX₁, TX₂, and TX₄ respectively transmit $L_a(v_4, s_1)$, $L_b(u_4, s_2)$, and $L_d(u_3, v_3)$, while TX₃ is silent. The linear combination $L'_c(L_a(v_4, s_1), L_b(u_4, s_2), L_d(u_3, v_3))$ will be desired by RX₁, RX₂, and RX₄ and available at TX₃.

▷ *Time slot $t = 15$:* TX₁, TX₃, and TX₄ respectively transmit $L_a(w_4, s_3)$, $L_c(u_6, s_4)$, and $L_d(u_5, w_3)$, while TX₂ is silent. The linear combination $L'_b(L_a(w_4, s_3), L_c(u_6, s_4), L_d(u_5, w_3))$ will be desired by RX₁, RX₃, and RX₄ and available at TX₂.

▷ *Time slot $t = 16$:* TX₂, TX₃, and TX₄ respectively transmit $L_b(w_6, s_5)$, $L_c(v_6, s_6)$, and $L_d(v_5, w_5)$, while TX₁ is silent. The linear combination $L'_a(L_b(w_6, s_5), L_c(v_6, s_6), L_d(v_5, w_5))$ will be desired by RX₂, RX₃, and RX₄ and available at TX₁.

The symbols L'_a , L'_b , L'_c , and L'_d will be delivered to their respective triples of receivers in phase 3.

Phase 3 (4-user IC with output feedback):

This phase takes 3 time slots. In each time slot, the symbols (linear combinations) L'_a , L'_b , L'_c , and L'_d are transmitted by TX₁, TX₂, TX₃, and TX₄, respectively. Similar to the full-duplex delayed CSIT, by the end of this phase, each receiver will decode its desired symbols.

4-user IC with Shannon Feedback

Phase 2 (4-user IC with Shannon Feedback):

This phase takes 4 time slots as follows:

▷ *Time slot $t = 13$* : Recall from phase 1 that $L_a(v_2, w_1)$, $L_b(u_2, w_2)$, and $L_c(u_1, v_1)$ are all available at each of TX₁, TX₂, and TX₃. We also note that if we deliver two random linear combinations of these three quantities to RX₁, RX₂, and RX₃, then each of them will be able to decode its two desired quantities out of these three quantities. Hence, two random linear combinations of them with offline generated coefficients are simultaneously transmitted by two transmitters out of TX₁, TX₂, and TX₃ (say, TX₁ and TX₂). Then, each of RX₁, RX₂, and RX₃ receives one linear equation in terms of $L_a(v_2, w_1)$, $L_b(u_2, w_2)$, and $L_c(u_1, v_1)$ and requires another random linear combination to resolve both desired quantities. Thus, the linear combination $L'_d(L_a(v_2, w_1), L_b(u_2, w_2), L_c(u_1, v_1))$ which is received by RX₄ is desired by each of the other three receivers. Also, this linear combination is available at TX₄ through the output feedback and is available at the other transmitters, since they all have $L_a(v_2, w_1)$, $L_b(u_2, w_2)$, and $L_c(u_1, v_1)$.

The remaining 3 time slots are similarly dedicated to transmission of other linear combinations as follows:

▷ *Time slot $t = 14$* : Two random linear combinations of $L_a(v_4, s_1)$, $L_b(u_4, s_2)$, and $L_d(u_3, v_3)$ are transmitted by TX₄ and TX₁. The linear combination $L'_c(L_a(v_4, s_1), L_b(u_4, s_2), L_d(u_3, v_3))$ which is received by RX₃ is desired by each of the other three receivers, and is available at all 4 transmitters.

▷ *Time slot $t = 15$* : Two random linear combinations of $L_a(w_4, s_3)$, $L_c(u_6, s_4)$, and $L_d(u_5, w_3)$ are transmitted by TX₃ and TX₄. The linear combination $L'_b(L_a(w_4, s_3), L_c(u_6, s_4), L_d(u_5, w_3))$ which is received by RX₂ is desired by each of the other three receivers, and is available at all 4 transmitters.

▷ *Time slot $t = 16$* : Two random linear combinations of $L_b(w_6, s_5)$, $L_c(v_6, s_6)$, and $L_d(v_5, w_5)$ are transmitted by TX₂ and TX₃. The linear combination $L'_a(L_b(w_6, s_5), L_c(v_6, s_6), L_d(v_5, w_5))$ which is received by RX₁ is desired by each of the other three receivers, and is available at all 4 transmitters.

The transmission in phase 2 for the 4-user IC with Shannon feedback is illustrated in Fig. 4.5.

Phase 3 (4-user IC with Shannon feedback):

Over 3 time slots, one of the transmitters, say TX_1 , transmits 3 random linear combinations of L'_a, L'_b, L'_c , and L'_d , and thus, each receiver will decode its desired symbols by the end of this phase.

Our achievable DoF for the 4-user IC under each of the feedback/cooperation assumptions will then be $24/(12 + 4 + 3) = 24/19$.

Remark 5. *Although the proposed transmission schemes for the 3-user and 4-user IC achieve the same DoF under each of the channel feedback/cooperation assumptions, this is not generally the case as it will be seen later. Indeed, for $K > 6$, the proposed transmission schemes achieve strictly different DoFs under different feedback/cooperation assumptions.*

4.3 Illustrative Examples: X Channel

In this section, we illustrate our transmission schemes for the 2×2 and 3×3 X channel under each of the channel feedback/cooperation assumptions (a)-(c). Before proceeding with the details of the transmission schemes, let us introduce a notation which is exclusively used in this section:

Notation 6. *The symbols u^a, u^b , and u^c denote information symbols of TX_1, TX_2 , and TX_3 , respectively, all intended for RX_1 . Similarly, v^a, v^b , and v^c denote information symbols intended for RX_2 , and w^a, w^b , and w^c are all intended for RX_3 .*

We also use the same notations for the linear combinations and their colouring as defined in Notation 5.

4.3.1 2×2 X Channel

It is already known that 2×2 X channel can achieve $4/3$ DoF with output feedback [35]. This is indeed the DoF of 2-user MISO broadcast channel with Shannon feedback [34],

CHAPTER 4: FULL-DUPLEX TX COOPERATION AND FEEDBACK

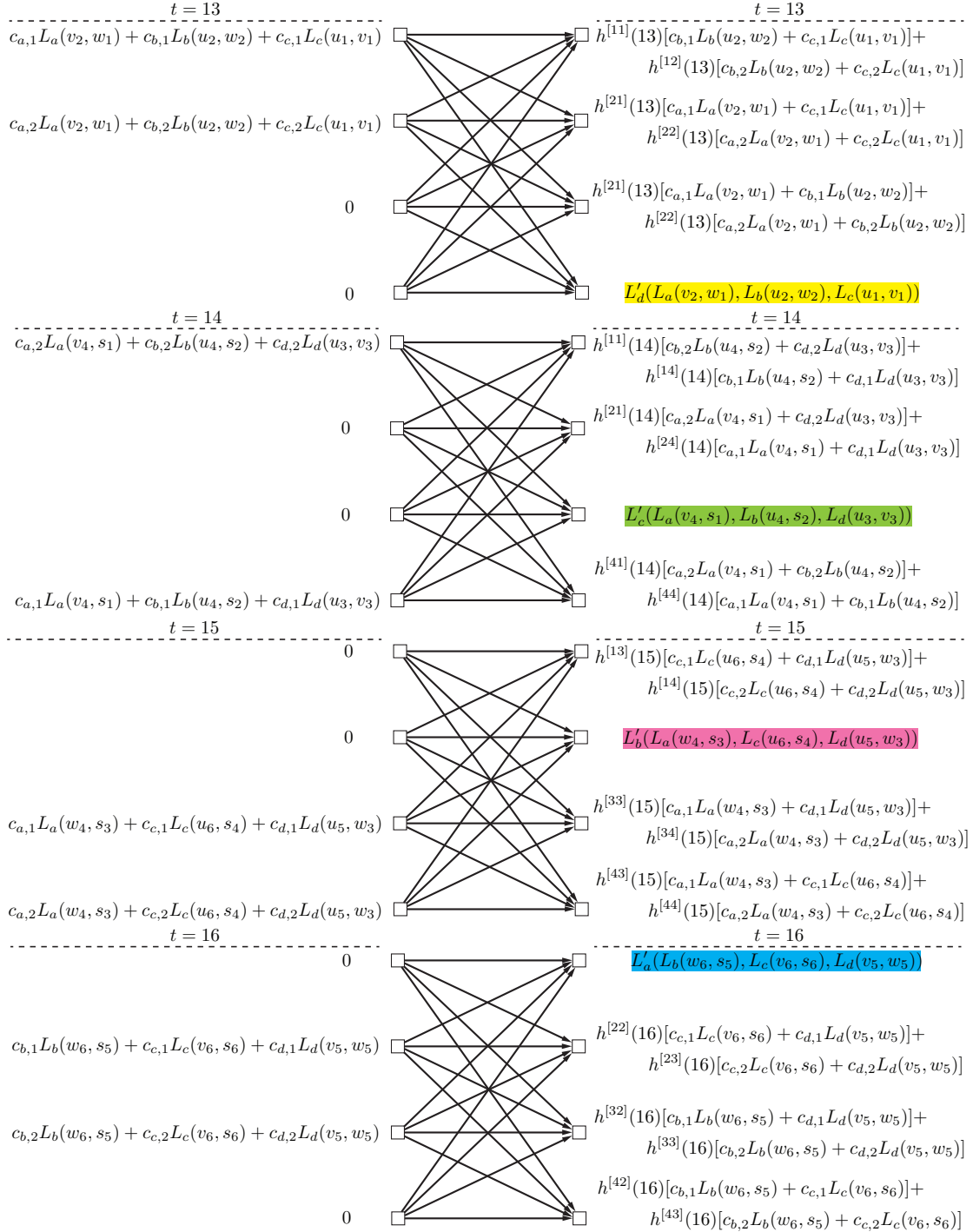

Figure 4.5: Phase 2 of the transmission scheme for 4-user IC with Shannon feedback. Each coloured linear combination is the one which is (i) available at a receiver, (ii) not desired by that receiver, and (iii) desired by the other receivers.

CHAPTER 4: FULL-DUPLEX TX COOPERATION AND FEEDBACK

which is also an upper bound to the DoF of 2×2 X channel under each of the assumptions (a)-(c). Hence, the DoF of 2×2 X channel with output feedback or with Shannon feedback is equal to $4/3$. In this section, we show that 2×2 X channel has the same DoF under the full-duplex delayed CSIT assumption as well. The transmission scheme operates in parallel with scheme proposed in [34] for the 2-user MISO broadcast channel and employed in [35] for the 2×2 X channel with output feedback. It is a two-phase transmission scheme depicted in Fig. 4.6, wherein the fresh information symbols are transmitted over the channel in the first phase and delivery of the symbols to their intended receivers is completed in the second phase. In particular, 4 information symbols are delivered in 3 time slots as follows:

Phase 1 (Full-duplex 2×2 X Channel with Delayed CSIT):

This phase takes 2 time slots to transmit 4 information symbols as follows:

▷ *First time slot:* The symbols u^a and u^b are transmitted by TX₁ and TX₂, respectively. Ignoring the noise, RX₁ will receive a linear equation

$$L_a(u^a, u^b) = h^{[11]}(1)u^a + h^{[12]}(1)u^b, \quad (4.11)$$

in terms of 2 desired information symbols, and hence, requires another linearly independent equation to resolve them. Simultaneously, RX₂ receives another linear equation, namely,

$$L_b(u^a, u^b) = h^{[21]}(1)u^a + h^{[22]}(1)u^b, \quad (4.12)$$

in terms of u^a and u^b . Since the channel coefficients are i.i.d. across the channel nodes, $L_b(u^a, u^b)$ is linearly independent of $L_a(u^a, u^b)$ almost surely. Therefore, if we deliver $L_b(u^a, u^b)$ to RX₁ it will be able to decode both u^a and u^b . On the other hand, according to full-duplex operation of the transmitters, both TX₁ and TX₂ will have both u^a and u^b , and by the delayed CSIT assumption, they can reconstruct $L_b(u^a, u^b)$ after this time slot.

▷ *Second time slot:* Similarly, v^a and v^b are transmitted respectively by TX₁ and TX₂. Then, the linear combination

$$L_a(v^a, v^b) = h^{[11]}(2)v^a + h^{[12]}(2)v^b, \quad (4.13)$$

which is received by RX₁ will be desired by RX₂ and available at both TX₁ and TX₂.

CHAPTER 4: FULL-DUPLEX TX COOPERATION AND FEEDBACK

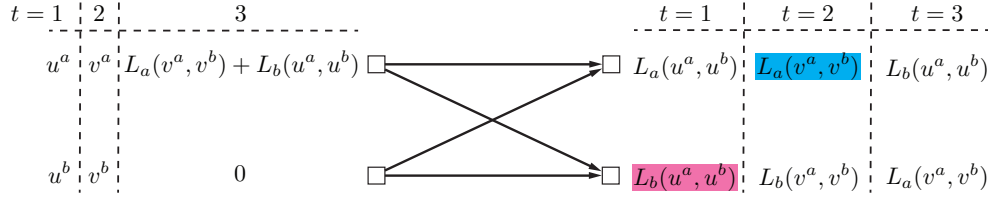

Figure 4.6: The transmission scheme for full-duplex 2×2 X channel with delayed CSIT. Each coloured linear combination is the one which is (i) available at a receiver, (ii) not desired by that receiver, and (iii) desired by the other receiver.

Therefore, it only remains to deliver $L_b(u^a, u^b)$ and $L_a(v^a, v^b)$ to RX₁ and RX₂ respectively. This is accomplished in one time slot in phase 2:

Phase 2 (Full-duplex 2×2 X Channel with Delayed CSIT):

▷ *Third time slot:* One of the transmitters, say TX₁, transmits $L_b(u^a, u^b) + L_a(v^a, v^b)$, while the other transmitter is silent. RX₁ receives this linear combination, and it can cancel $L_a(v^a, v^b)$ which it already has, to obtain the desired quantity $L_b(u^a, u^b)$. Similarly, RX₂ can cancel $L_b(u^a, u^b)$ to obtain $L_a(v^a, v^b)$.

4.3.2 3×3 X Channel

For this channel, we achieve 24/17 DoF with full-duplex delayed CSIT. We also achieve 3/2 DoF and 27/17 DoF with output feedback and Shannon feedback, respectively. In the following, we show the achievability of each of the above DoFs:

Full-duplex 3×3 X Channel with Delayed CSIT

We propose a 3-phase transmission scheme which delivers 72 information symbols in 51 time slots, and thus, achieves 24/17 DoF as follows:

Phase 1 (Full-duplex 3×3 X Channel with Delayed CSIT):

This phase takes 12 times slots to transmit 24 information symbols.

CHAPTER 4: FULL-DUPLEX TX COOPERATION AND FEEDBACK

▷ *Time slots* $t = 1, \dots, 6$: Only TX₁ and TX₂ transmit information symbols, and TX₃ is silent. In particular, for each pair of receivers, TX₁ and TX₂ use 2 time slots to transmit 4 information symbols exactly as in phase 1 of the scheme proposed above for the full-duplex 2×2 X channel with delayed CSIT.

▷ *Time slots* $t = 7, \dots, 12$: Similarly, another 12 information symbols are now transmitted by TX₁ and TX₃, while TX₂ is silent.

The transmission in this phase is illustrated in Fig. 4.7. Each coloured linear combination in the figure is available at one receiver and desired by another receiver, and will also be reconstructed by two of the transmitters after its corresponding time slot. For example, $L_b(u_1^a, u_1^b)$ is available at RX₂ and desired by RX₁, and will be reconstructed by TX₁ and TX₂ after the first time slot. Now, it only remains to deliver the following 6 linear combinations to their respective pairs of receivers (as discussed in phase 2 of the full-duplex 2×2 X channel with delayed CSIT):

$$\text{TX}_1 \ \& \ \text{TX}_2 \ \begin{cases} L_b(u_1^a, u_1^b) + L_a(v_1^a, v_1^b) & \longrightarrow \text{RX}_1 \ \& \ \text{RX}_2 \\ L_c(u_2^a, u_2^b) + L_a(w_1^a, w_1^b) & \longrightarrow \text{RX}_1 \ \& \ \text{RX}_3, \\ L_c(v_2^a, v_2^b) + L_b(w_2^a, w_2^b) & \longrightarrow \text{RX}_2 \ \& \ \text{RX}_3 \end{cases} \quad (4.14)$$

$$\text{TX}_1 \ \& \ \text{TX}_3 \ \begin{cases} L_b(u_3^a, u_1^c) + L_a(v_3^a, v_1^c) & \longrightarrow \text{RX}_1 \ \& \ \text{RX}_2 \\ L_c(u_4^a, u_2^c) + L_a(w_3^a, w_1^c) & \longrightarrow \text{RX}_1 \ \& \ \text{RX}_3. \\ L_c(v_4^a, v_2^c) + L_b(w_4^a, w_2^c) & \longrightarrow \text{RX}_2 \ \& \ \text{RX}_3 \end{cases} \quad (4.15)$$

This will be accomplished during the remaining phases of the transmission scheme.

Phase 2 (Full-duplex 3×3 X Channel with Delayed CSIT):

This phase takes 3 time slots to transmit the linear combinations indicated in (4.14) and (4.15) by TX₁ and TX₂ as follows. TX₃ is silent in this phase.

▷ *Time slot* $t = 13$: TX₁ and TX₂ transmit $L_b(u_3^a, u_1^c) + L_a(v_3^a, v_1^c)$ and $L_b(u_1^a, u_1^b) + L_a(v_1^a, v_1^b)$, respectively, while TX₃ is silent. By the end of this time slot, RX₁ obtains a linear combination in terms of the (desired) L_b quantities (after cancelling the known

CHAPTER 4: FULL-DUPLEX TX COOPERATION AND FEEDBACK

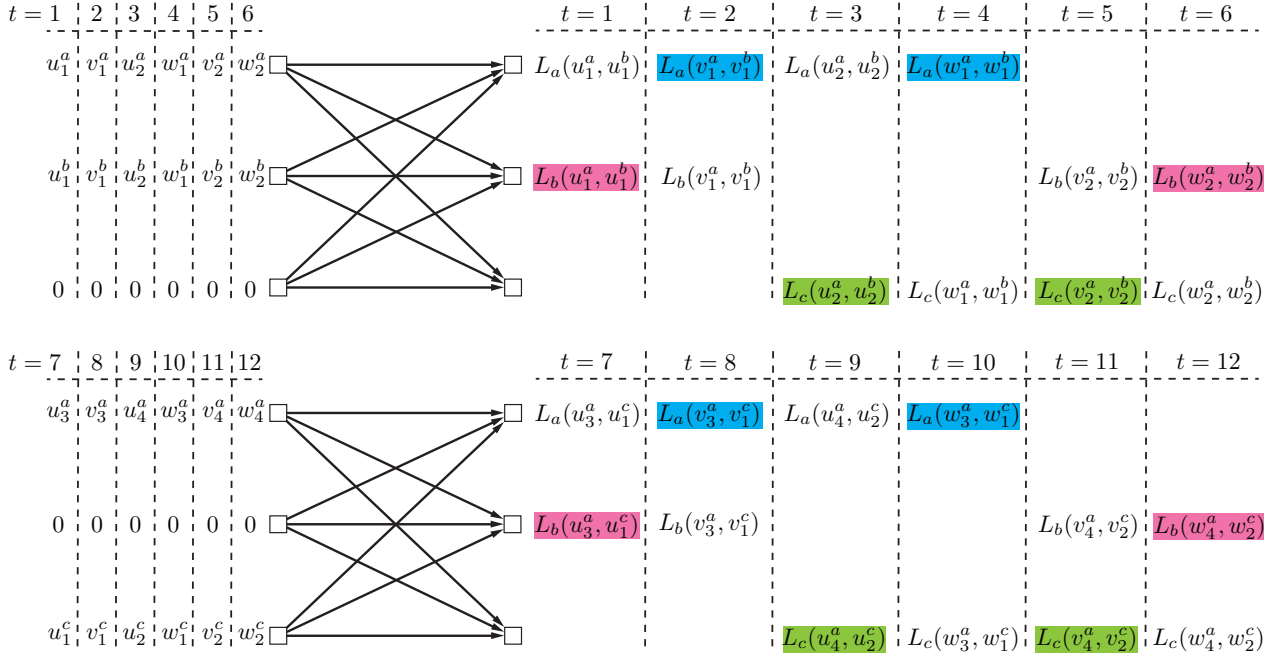

Figure 4.7: Phase 1 of the transmission scheme for full-duplex 3×3 X channel with delayed CSIT. Each coloured linear combination is the one which is (i) available at a receiver, (ii) not desired by that receiver, and (iii) desired by one of the other receivers.

L_a quantities). Hence, it requires another linearly independent combination of the L_b quantities to decode both of them. Similarly, RX_2 obtains a linear combination of the (desired) L_a quantities and needs another linearly independent combination of them to decode both. Now, one can easily verify that the linear combination

$$L'_c = h^{[31]}(13)[L_b(u_3^a, u_1^c) + L_a(v_3^a, v_1^c)] + h^{[32]}(13)[L_b(u_1^a, u_1^b) + L_a(v_1^a, v_1^b)], \quad (4.16)$$

received by RX_3 during this time slot, is linearly independent of the linear combination received by each of RX_1 and RX_2 . Therefore, if we deliver this linear combination to both RX_1 and RX_2 , each of them will be able to decode its both desired L_b or L_a quantities. On the other hand, by the delayed CSIT assumption, L'_c is available at TX_1 as well (note that TX_1 has both transmitted linear combinations).

The next two time slots are similarly dedicated to the other pairs of receivers:

CHAPTER 4: FULL-DUPLEX TX COOPERATION AND FEEDBACK

▷ *Time slot $t = 14$* : TX₁ and TX₂ transmit $L_c(u_4^a, u_2^c) + L_a(w_3^a, w_1^c)$ and $L_c(u_2^a, u_2^b) + L_a(w_1^a, w_1^b)$, respectively. Now, each of RX₁ and RX₃ receives a desired linear combination and the linear combination

$$L'_b = h^{[21]}(14)[L_c(u_4^a, u_2^c) + L_a(w_3^a, w_1^c)] + h^{[22]}(14)[L_c(u_2^a, u_2^b) + L_a(w_1^a, w_1^b)], \quad (4.17)$$

received by RX₂ during this time slot, will be desired by both RX₁ and RX₃. This linear combination is also available at TX₁ after this time slot.

▷ *Time slot $t = 15$* : TX₁ and TX₂ transmit $L_c(v_4^a, v_2^c) + L_b(w_4^a, w_2^c)$ and $L_c(v_2^a, v_2^b) + L_b(w_2^a, w_2^b)$, respectively. Each of RX₂ and RX₃ receives a desired linear combination and the linear combination

$$L'_a = h^{[11]}(15)[L_c(v_4^a, v_2^c) + L_b(w_4^a, w_2^c)] + h^{[12]}(15)[L_c(v_2^a, v_2^b) + L_b(w_2^a, w_2^b)], \quad (4.18)$$

received by RX₁ during this time slot, will be desired by both RX₂ and RX₃. This linear combination is also available at TX₁ after this time slot.

In summary, the linear combinations L'_a , L'_b , and L'_c each are available at one receiver and desired by the other two receivers, and all of them are available at TX₁. They will be delivered to their respective pairs of receivers in phase 3.

Phase 3 (Full-duplex 3×3 X Channel with Delayed CSIT):

▷ *Time slots $t = 16, 17$* : In each time slot, a random linear combination of L'_a , L'_b , and L'_c is transmitted by TX₁, while the rest of transmitters are silent. It can be easily verified that after these two time slots, each receiver will be able to decode its both desired quantities.

3×3 X Channel with Output Feedback

Our transmission scheme for this channel is a 2-phase scheme wherein 9 information symbols are delivered to the receivers in 6 time slots, yielding 3/2 DoF, as illustrated in Fig. 4.8 and elaborated on in the following:

CHAPTER 4: FULL-DUPLEX TX COOPERATION AND FEEDBACK

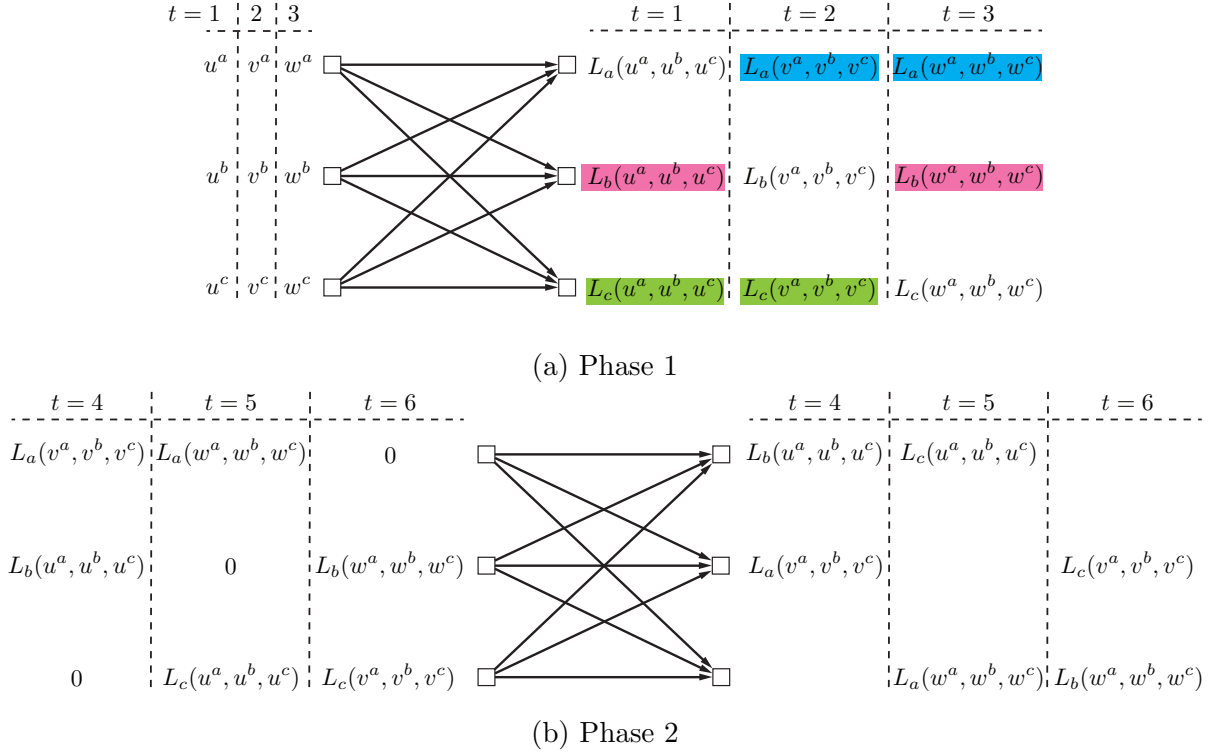

Figure 4.8: Transmission scheme for 3×3 X channel with output feedback. Each coloured linear combination is the one which is (i) available at a receiver, (ii) not desired by that receiver, and (iii) desired by one of the other receivers.

Phase 1 (3×3 X Channel with Output Feedback): This phase has 3 time slots. Each time slot is dedicated to transmission of information symbols intended for one of the receivers:

▷ *First time slot:* The information symbols u^a , u^b , and u^c , all intended for RX_1 , are transmitted by TX_1 , TX_2 and TX_3 , respectively. By the end of this time slot, RX_1 receives linear combination $L_a(u^a, u^b, u^c)$ of the three desired symbols and requires two extra linearly independent equations to resolve all three symbols. RX_2 receives the linear combination $L_b(u^a, u^b, u^c)$ which is linearly independent of $L_a(u^a, u^b, u^c)$, and thus, is desired by RX_1 . Similarly, the linear combination $L_c(u^a, u^b, u^c)$ received by RX_3 is desired by RX_1 . On the other hand, $L_b(u^a, u^b, u^c)$ (resp. $L_c(u^a, u^b, u^c)$) will be also available at TX_2 (resp. TX_3) through the output feedback.

CHAPTER 4: FULL-DUPLEX TX COOPERATION AND FEEDBACK

The second and third time slots are similarly dedicated to RX₂ and RX₃, respectively:

▷ *Second time slot:* The information symbols v^a , v^b , and v^c , all intended for RX₂, are transmitted by TX₁, TX₂ and TX₃, respectively. Similarly, $L_a(v^a, v^b, v^c)$ and $L_c(v^a, v^b, v^c)$, received by RX₁ and RX₃ and available at TX₁ and TX₃ through the output feedback, will be desired by RX₁ after this time slot.

▷ *Third time slot:* The information symbols w^a , w^b , and w^c , all intended for RX₃, are transmitted by TX₁, TX₂ and TX₃, respectively. Similarly, $L_a(w^a, w^b, w^c)$ and $L_b(w^a, w^b, w^c)$, received by RX₁ and RX₂ and available at TX₁ and TX₂ through the output feedback, will be desired by RX₃ after this time slot.

Therefore, to deliver the transmitted information symbols to their intended receivers, it suffices to

- (i) deliver $L_b(u^a, u^b, u^c)$ and $L_c(u^a, u^b, u^c)$ to RX₁;
- (ii) deliver $L_a(v^a, v^b, v^c)$ and $L_c(v^a, v^b, v^c)$ to RX₂;
- (iii) deliver $L_a(w^a, w^b, w^c)$ and $L_b(w^a, w^b, w^c)$ to RX₃.

This will be done in phase 2.

Phase 2 (3×3 X Channel with Output Feedback):

This phase takes 3 time slots. Each time slot is dedicated to a pair of receivers as follows:

▷ *Fourth time slot:* Over this time slot, which is dedicated to RX₁ and RX₂, $L_a(v^a, v^b, v^c)$ and $L_b(u^a, u^b, u^c)$ are respectively transmitted by TX₁ and TX₂, while TX₃ is silent. After this time slot, RX₁ obtains the desired linear combination L_b by cancelling the known undesired linear combination L_a . Similarly, RX₂ obtains its own desired linear combination L_a by cancelling L_b .

▷ *Fifth time slot:* The quantities $L_a(w^a, w^b, w^c)$ and $L_c(u^a, u^b, u^c)$ are transmitted by TX₁ and TX₃, while TX₂ is silent. Then, each of RX₁ and RX₃ similarly obtains its desired quantity.

CHAPTER 4: FULL-DUPLEX TX COOPERATION AND FEEDBACK

▷ *Sixth time slot:* The quantities $L_b(w^a, w^b, w^c)$ and $L_c(v^a, v^b, v^c)$ are transmitted by TX₂ and TX₃, while TX₁ is silent. Then, each of RX₂ and RX₃ similarly obtains its desired quantity.

3 × 3 X Channel with Shannon Feedback

Our transmission scheme for this channel has two rounds of operation, during which 27 information symbols are delivered to the receivers in 17 time slots as follows:

► *Round 1 (3 × 3 X Channel with Shannon Feedback):*

The first round consists of two phases. Phase 1 takes 3 time slots to transmit 9 information symbols $\{u_1^a, u_1^b, u_1^c, v_1^a, v_1^b, v_1^c, w_1^a, w_1^b, w_1^c\}$ exactly as in phase 1 of the scheme proposed above for the same channel with output feedback. Before proceeding with phase 2, one notes that TX₁ after the first time slot will obtain the linear combination

$$L_a(u_1^a, u_1^b, u_1^c) = h^{[11]}(1)u_1^a + h^{[12]}(1)u_1^b + h^{[13]}(1)u_1^c, \quad (4.19)$$

through the output feedback. Since TX₁ has access to delayed CSI as well (Shannon feedback assumption), it can cancel its own transmitted symbols u_1^a to obtain

$$h^{[12]}(1)u_1^b + h^{[13]}(1)u_1^c, \quad (4.20)$$

which is a linear combination of u_1^b and u_1^c . TX₁ knows the coefficients $h^{[12]}(1)$ and $h^{[13]}(1)$ of this linear combination. Similarly, TX₂ will obtain $h^{[21]}(2)v_1^a + h^{[23]}(2)v_1^c$ after the second time slot using Shannon feedback.

In phase 2, over one time slot, TX₁ and TX₂ transmit $L_a(v_1^a, v_1^b, v_1^c)$ and $L_b(u_1^a, u_1^b, u_1^c)$, while TX₃ is silent. Hence, $L_a(v_1^a, v_1^b, v_1^c)$ and $L_b(u_1^a, u_1^b, u_1^c)$ are delivered to RX₂ and RX₁, respectively (as in the phase 2 of the scheme proposed with output feedback). Now, TX₁ will obtain $L_b(u_1^a, u_1^b, u_1^c)$ since it has access to Shannon feedback and its own transmitted quantity i.e., $L_a(v_1^a, v_1^b, v_1^c)$. Therefore, by cancelling u_1^a from $L_b(u_1^a, u_1^b, u_1^c)$, TX₁ will obtain

$$h^{[22]}(1)u_1^b + h^{[23]}(1)u_1^c, \quad (4.21)$$

which is another linear combination of u_1^b and u_1^c . Hence, using (4.20) and (4.21), TX₁ will be able to decode both u_1^b and u_1^c . Thereby, having access to delayed CSI, TX₁ can

CHAPTER 4: FULL-DUPLEX TX COOPERATION AND FEEDBACK

reconstruct $L_c(u_1^a, u_1^b, u_1^c)$. Likewise, TX₂ will be able to decode both v_1^a and v_1^c , and hence, can reconstruct $L_c(v_1^a, v_1^b, v_1^c)$.

In summary, after these 4 time slots, it only remains to

- (i) deliver $L_c(u_1^a, u_1^b, u_1^c)$ to RX₁;
- (ii) deliver $L_c(v_1^a, v_1^b, v_1^c)$ to RX₂;
- (iii) deliver $L_a(w_1^a, w_1^b, w_1^c)$ and $L_b(w_1^a, w_1^b, w_1^c)$ to RX₃.

On the other hand, TX₁ has access to $L_c(u_1^a, u_1^b, u_1^c)$ by above argument and has access to $L_a(w_1^a, w_1^b, w_1^c)$ using output feedback. Similarly, TX₂ has access to $L_c(v_1^a, v_1^b, v_1^c)$ and $L_b(w_1^a, w_1^b, w_1^c)$. Hence, it suffices to deliver the following two linear combinations to their respective pairs of receivers:

$$\text{TX}_1 : L_c(u_1^a, u_1^b, u_1^c) + L_a(w_1^a, w_1^b, w_1^c) \longrightarrow \text{RX}_1 \ \& \ \text{RX}_3, \quad (4.22)$$

$$\text{TX}_2 : L_c(v_1^a, v_1^b, v_1^c) + L_b(w_1^a, w_1^b, w_1^c) \longrightarrow \text{RX}_2 \ \& \ \text{RX}_3. \quad (4.23)$$

Before proceeding with the second round, we repeat the above procedure two more times and transmit another $2 \times 9 = 18$ *fresh* information symbols, namely $\{u_i^a, u_i^b, u_i^c, v_i^a, v_i^b, v_i^c, w_i^a, w_i^b, w_i^c\}_{i=2,3}$, in another $2 \times 4 = 8$ time slots. However, in the first repetition, $L_a(w_2^a, w_2^b, w_2^c)$ and $L_c(u_2^a, u_2^b, u_2^c)$ are transmitted by TX₁ and TX₃ in phase 2, and it will suffice to deliver the following two linear combinations to their respective pairs of receivers:

$$\text{TX}_1 : L_b(w_2^a, w_2^b, w_2^c) + L_a(u_2^a, u_2^b, u_2^c) \longrightarrow \text{RX}_1 \ \& \ \text{RX}_2, \quad (4.24)$$

$$\text{TX}_3 : L_b(w_2^a, w_2^b, w_2^c) + L_c(v_2^a, v_2^b, v_2^c) \longrightarrow \text{RX}_2 \ \& \ \text{RX}_3. \quad (4.25)$$

Similarly, in the second repetition, $L_b(w_3^a, w_3^b, w_3^c)$ and $L_c(v_3^a, v_3^b, v_3^c)$ are transmitted by TX₂ and TX₃ in phase 2, and it will suffice to deliver the following two linear combinations to their respective pairs of receivers:

$$\text{TX}_2 : L_a(v_3^a, v_3^b, v_3^c) + L_b(u_3^a, u_3^b, u_3^c) \longrightarrow \text{RX}_1 \ \& \ \text{RX}_2, \quad (4.26)$$

$$\text{TX}_3 : L_a(v_3^a, v_3^b, v_3^c) + L_c(u_3^a, u_3^b, u_3^c) \longrightarrow \text{RX}_1 \ \& \ \text{RX}_3. \quad (4.27)$$

CHAPTER 4: FULL-DUPLEX TX COOPERATION AND FEEDBACK

Up to this point, we have spent 12 time slots, transmitted 27 information symbols. Now, we need to deliver the above 6 linear combinations to their respective pairs of receivers. This will be done in the second round.

► *Round 2 (3 × 3 X Channel with Shannon Feedback):*

This round takes 5 time slots, i.e., $t = 13, \dots, 17$. During the first 3 time slots the above 6 linear combinations are transmitted over the channel. Each time slot is dedicated to a pair of receivers as follows:

▷ *Time slot $t = 13$:* TX₁ and TX₂ respectively transmit $L_b(u_2^a, u_2^b, u_2^c) + L_a(v_2^a, v_2^b, v_2^c)$ and $L_a(v_3^a, v_3^b, v_3^c) + L_b(u_3^a, u_3^b, u_3^c)$ (both to be delivered to RX₁ and RX₂ according to (4.24) and (4.26)), while TX₃ is silent. Then, using an argument similar to the phase 2 of the transmission scheme proposed for the full-duplex 3 × 3 X channel with delayed CSIT, RX₁ (resp. RX₂) receives an equation in terms of the (desired) linear combinations $L_b(u_2^a, u_2^b, u_2^c)$ and $L_b(u_3^a, u_3^b, u_3^c)$ (resp. $L_a(v_2^a, v_2^b, v_2^c)$ and $L_a(v_3^a, v_3^b, v_3^c)$). Also, the equation

$$L'_c = h^{[31]}(13)[L_b(u_2^a, u_2^b, u_2^c) + L_a(v_2^a, v_2^b, v_2^c)] + h^{[32]}(13)[L_a(v_3^a, v_3^b, v_3^c) + L_b(u_3^a, u_3^b, u_3^c)], \quad (4.28)$$

received by RX₃ in this time slot will be desired by both RX₁ and RX₂. It can also be easily verified that L'_c can be reconstructed by TX₁ due to Shannon feedback.

▷ *Time slot $t = 14$:* TX₁ and TX₃ respectively transmit $L_c(u_1^a, u_1^b, u_1^c) + L_a(w_1^a, w_1^b, w_1^c)$ and $L_a(w_3^a, w_3^b, w_3^c) + L_c(u_3^a, u_3^b, u_3^c)$, both desired by RX₁ and RX₃, while TX₂ is silent. Then, the linear combination

$$L'_b = h^{[21]}(14)[L_c(u_1^a, u_1^b, u_1^c) + L_a(w_1^a, w_1^b, w_1^c)] + h^{[23]}(14)[L_a(w_3^a, w_3^b, w_3^c) + L_c(u_3^a, u_3^b, u_3^c)], \quad (4.29)$$

received by RX₂ will be desired by both RX₁ and RX₃ and can be reconstructed by TX₁ using Shannon feedback.

▷ *Time slot $t = 15$:* TX₂ and TX₃ respectively transmit $L_b(w_2^a, w_2^b, w_2^c) + L_c(v_2^a, v_2^b, v_2^c)$ and $L_b(w_2^a, w_2^b, w_2^c) + L_c(v_2^a, v_2^b, v_2^c)$, both desired by RX₂ and RX₃, while TX₁ is silent. Then, the linear combination

$$L'_a = h^{[12]}(15)[L_b(w_2^a, w_2^b, w_2^c) + L_c(v_2^a, v_2^b, v_2^c)] + h^{[13]}(15)[L_b(w_2^a, w_2^b, w_2^c) + L_c(v_2^a, v_2^b, v_2^c)], \quad (4.30)$$

CHAPTER 4: FULL-DUPLEX TX COOPERATION AND FEEDBACK

received by RX_1 will be desired by both RX_2 and RX_3 and is received by TX_1 using Shannon feedback (output feedback).

During the last 2 time slots of this round, the linear combinations L'_a , and L'_b , and L'_c are delivered to their intended pairs of receivers:

▷ *Time slots $t = 16, 17$:* Two random linear combinations of L'_a , and L'_b , and L'_c are transmitted by TX_1 , while the rest of transmitters are silent. Each receiver will then be able to decode its two desired linear combinations.

The achieved DoF is therefore equal to $27/(12 + 3 + 2) = 27/17$.

4.4 Main Results

The main results of this chapter are summarized in the following six theorems. The proof of each theorem is provided in its respective section.

4.4.1 Full-duplex Transmitter Cooperation and Delayed CSIT

Theorem 7. *The K -user ($K \geq 3$) SISO Gaussian interference channel with delayed CSIT and full-duplex transmitters can achieve $\underline{\text{DoF}}_1^{\text{ICFD}}(K)$ degrees of freedom almost surely, where $\underline{\text{DoF}}_1^{\text{ICFD}}(K)$ is given by*

$$\underline{\text{DoF}}_1^{\text{ICFD}}(K) = \frac{4}{3 - \frac{2}{\lceil \frac{K}{2} \rceil (\lceil \frac{K}{2} \rceil - 1)} + \frac{4}{\lfloor \frac{K}{2} \rfloor (\lfloor \frac{K}{2} \rfloor - 1)} \sum_{\ell=\lceil \frac{K}{2} \rceil+1}^K \frac{1}{\ell}}. \quad (4.31)$$

Proof. See Section 4.5.1. □

Theorem 8. *The $M \times K$ SISO Gaussian X channel with delayed CSIT and full-duplex transmitters can achieve $\underline{\text{DoF}}_1^{\text{XFD}}(M, K)$ degrees of freedom almost surely, where $\underline{\text{DoF}}_1^{\text{XFD}}(M, K)$ is given by*

$$\begin{cases} \left(\frac{1}{\lceil \frac{K}{2} \rceil} - 1 + \sum_{\ell_1=1}^{\lceil \frac{K}{2} \rceil - 1} \frac{1}{\ell_1^2} + \frac{1}{\lceil \frac{K}{2} \rceil (\lceil \frac{K}{2} \rceil + 1)} \sum_{\ell_2=\lceil \frac{K}{2} \rceil}^K \frac{1}{\ell_2} \right)^{-1}, & M > \lceil \frac{K}{2} \rceil \\ \left(\frac{1}{M-1} - 1 + \sum_{\ell_1=1}^{M-2} \frac{1}{\ell_1^2} + \frac{1}{M^2} \sum_{\ell_2=M-1}^K \frac{1}{\ell_2} \left(\frac{M-1}{M} \right)^{\min(\ell_2, K-M+1)-M} \right)^{-1}, & M \leq \lceil \frac{K}{2} \rceil \end{cases}. \quad (4.32)$$

Proof. See Section 4.5.2. □

4.4.2 Output Feedback

Theorem 9. *The K -user ($K \geq 3$) SISO Gaussian interference channel with output feedback can achieve $\underline{\text{DoF}}_1^{\text{ICOF}}(K)$ degrees of freedom almost surely, where $\underline{\text{DoF}}_1^{\text{ICOF}}(K)$ is given by*

$$\underline{\text{DoF}}_1^{\text{ICOF}}(K) = \max_{w \in \{\lfloor w_K^* \rfloor, \lceil w_K^* \rceil\}} \frac{w}{a(K)w(w-1)^2 + (w+1)/2}, \quad (4.33)$$

with w_K^* and $a(K)$ defined as

$$w_K^* \triangleq \frac{1}{3} + \frac{1}{6} \left(\frac{8a(K) + 3\sqrt{48a(K) + 81 + 27}}{a(K)} \right)^{\frac{1}{3}} + \frac{1}{6} \left(\frac{8a(K) - 3\sqrt{48a(K) + 81 + 27}}{a(K)} \right)^{\frac{1}{3}}, \quad (4.34)$$

$$a(K) \triangleq \frac{1}{\lceil \frac{K}{2} \rceil - 1} \left(-\frac{1}{2\lceil \frac{K}{2} \rceil} + \frac{1}{\lceil \frac{K}{2} \rceil} \sum_{\ell=\lceil \frac{K}{2} \rceil+1}^K \frac{1}{\ell} \right). \quad (4.35)$$

Proof. See Section 4.6.1. □

Theorem 10. *The $K \times K$ SISO Gaussian X channel with output feedback can achieve $\underline{\text{DoF}}_1^{\text{XOF}}(K, K) = \frac{2K}{K+1}$ degrees of freedom almost surely[†].*

Proof. See Section 4.6.2. □

4.4.3 Shannon Feedback

Theorem 11. *The K -user ($K \geq 3$) SISO Gaussian interference channel with Shannon feedback can achieve $\underline{\text{DoF}}_1^{\text{ICSF}}(K)$ degrees of freedom almost surely, where $\underline{\text{DoF}}_1^{\text{ICSF}}(K)$ is given by*

$$\underline{\text{DoF}}_1^{\text{ICSF}}(K) = \max_{\substack{2 \leq w \leq \lceil K/2 \rceil \\ w \in \mathbb{Z}^+}} \frac{w}{1 + \frac{w-2}{\underline{\text{DoF}}_w^{\text{ICOF}}(K)} + \frac{w}{(w+1)\underline{\text{DoF}}_{w+1}^{\text{ICSF}}(K)}}, \quad (4.36)$$

[†]The result of this theorem has been simultaneously and independently reported in [51]

CHAPTER 4: FULL-DUPLEX TX COOPERATION AND FEEDBACK

with $\underline{\text{DoF}}_m^{\text{ICOF}}(K)$ given by (4.58), and $\underline{\text{DoF}}_m^{\text{ICSF}}(K)$ given by

$$\begin{cases} \left(\frac{1}{m} + m(m-1) \left[\frac{1}{m} - \frac{1}{\lfloor \frac{K}{2} \rfloor} - \sum_{\ell_1=m+1}^{\lfloor \frac{K}{2} \rfloor} \frac{1}{\ell_1^2} + \frac{1}{\lfloor \frac{K}{2} \rfloor \lceil \frac{K}{2} \rceil} \sum_{\ell_2=\lfloor \frac{K}{2} \rfloor+1}^K \frac{1}{\ell_2} \right] \right)^{-1}, & 2 \leq m \leq \lfloor \frac{K}{2} \rfloor \\ \left(\frac{m}{K-m+1} \sum_{\ell=m}^K \frac{1}{\ell} \right)^{-1}, & \lfloor \frac{K}{2} \rfloor < m \leq K \end{cases}. \quad (4.37)$$

Proof. See Section 4.7.1. □

Theorem 12. *The $K \times K$ SISO Gaussian X channel with Shannon feedback can achieve $\underline{\text{DoF}}_1^{\text{XSF}}(K, K)$ degrees of freedom almost surely, where $\underline{\text{DoF}}_1^{\text{XSF}}(K, K)$ is given by*

$$\underline{\text{DoF}}_1^{\text{XSF}}(K, K) = \frac{K^2}{\frac{K^2+7K-6}{2} - \frac{2(K-1)}{\lfloor \frac{K}{2} \rfloor} - 2(K-1) \sum_{\ell_1=1}^{\lfloor \frac{K}{2} \rfloor} \frac{1}{\ell_1^2} + \frac{2(K-1)}{\lfloor \frac{K}{2} \rfloor \lceil \frac{K}{2} \rceil} \sum_{\ell_2=\lfloor \frac{K}{2} \rfloor+1}^K \frac{1}{\ell_2}}. \quad (4.38)$$

Proof. See Section 4.7.2. □

4.4.4 Some Comments

Before proceeding with the proof details, we highlight some key features of our proposed transmission schemes through the following observations:

1. For each of IC and X channel and under each of the feedback/cooperation assumptions, a “multi-phase” transmission scheme is proposed.
2. During phase 1, in each time slot, fresh information symbols are transmitted by a subset of transmitters such that:
 - (i) Each receiver receives a number of linear combinations of its own desired information symbols (and possibly some interference symbols). The received linear combinations are not enough to resolve all desired symbols (possibly including some interference symbols).
 - (ii) Each receiver also receives some linear combinations solely in terms of undesired information symbols. However, these linear combinations are desired by some

CHAPTER 4: FULL-DUPLEX TX COOPERATION AND FEEDBACK

other receivers in view of observation (2i). On the other hand, by the end of phase 1, each of these linear combinations will be also available at a subset of transmitters based on the feedback/cooperation assumption.

3. During the remaining transmission phases, the transmitters deliver the linear combinations mentioned in observation (2ii) to the receivers where they are desired:
 - (i) Phase m , $m \geq 2$, takes some linear combinations as its inputs. Each of these linear combinations is available at a subset of transmitters and is desired by a subset of cardinality m of receivers (and is *at most* available at one unintended receiver as well).
 - (ii) During phase m , the input linear combinations are transmitted over the channel such that each intended receiver obtains “part” of the information required to decode the input linear combinations. The rest of information required by each intended receiver (to decode all its desired linear combinations) is obtained by a subset of unintended receivers. These pieces of information will be delivered to the intended receivers during phases $m + 1, m + 2, \dots$.
 - (iii) In specific, the mentioned pieces of information (or a mixture of them) is now desired by a subset of cardinality $m + 1$ of receivers, and is available at a subset of transmitters and *at most* one unintended receiver. These linear combinations constitute the inputs of phase $m + 1$.
 - (iv) The transmission continues until the last phase. The input of the last phase is the linear combinations which are desired by all receivers (except for *at most* one unintended receiver where the linear combination is already available). These linear combinations are delivered to their intended receivers by an appropriate number of transmissions.
4. Under the full-duplex delayed CSIT assumption, for both IC and X channel, only two transmitters are simultaneously active in each time slot of phase 1.
5. Under the output feedback and Shannon feedback assumptions, in each time slot of phase 1,

- (i) for the X channel, all transmitters are simultaneously active.
 - (ii) for the IC, the number of active transmitters is a function of the number of users.
6. Under the Shannon feedback assumption, the schemes proposed for both IC and X channel operate in two rounds: The first round follows the scheme proposed for the output feedback. However, as the scheme proceeds, each transmitter obtains more information about the symbols of the other transmitters using Shannon feedback. Eventually, each transmitter will be able to decode some information symbols of the other transmitters. Then, the transmission scheme will move on to the second round, where more transmitters can cooperate in the rest of transmissions.

Here, we introduce some notations which are widely used in the subsequent proof sections, namely, Sections 4.5 to 4.7. These notations are consistent with Notation 3.

Notation 7. *In the $M \times K$ X channel (with arbitrary M), the subsets of cardinality m_1 and m_2 of transmitters and receivers are denoted by $\mathcal{S}_{m_1}^{(t)} \subseteq \mathcal{S}_M^{(t)}$ and $\mathcal{S}_{m_2}^{(r)} \subseteq \mathcal{S}_K^{(r)}$, respectively, where $\mathcal{S}_M^{(t)} = \{1, 2, \dots, M\}$ and $\mathcal{S}_K^{(r)} = \{1, 2, \dots, K\}$ are respectively the index sets of all transmitters and all receivers and $m_1 \leq M$, $m_2 \leq K$. A symbol which is available at all transmitters TX_i , $i \in \mathcal{S}_{m_1}^{(t)}$, and all receivers $RX_{j'}$, $j' \in \mathcal{S}_{m_3}^{(r)}$, and is intended to be decoded at all receivers RX_j , $j \in \mathcal{S}_{m_2}^{(r)}$, is denoted by $u^{[\mathcal{S}_{m_1}^{(t)}|\mathcal{S}_{m_2}^{(r)};\mathcal{S}_{m_3}^{(r)}]}$. The superscripts “(t)” and “(r)” may be omitted whenever it is clear. If $\mathcal{S}_{m_3}^{(r)} = \{\}$, the mentioned symbol is denoted by $u^{[\mathcal{S}_{m_1}^{(t)}|\mathcal{S}_{m_2}^{(r)}]}$ and is called an order- m_2 symbol.*

4.5 SISO Interference and X Channels with Full-duplex Transmitter Cooperation and Delayed CSIT

In this section, we investigate the impact of full-duplex transmitter cooperation on the DoF of the K -user IC and $M \times K$ X channel with delayed CSIT. We will demonstrate how transmitters can exploit their knowledge about each other’s messages (attained through the full-duplex cooperation) combined with the delayed CSIT to achieve a higher DoF

compared to the non-cooperative delayed CSIT. In specific, we prove Theorems 7 and 8 as follows:

4.5.1 Proof of Theorem 7

Our transmission scheme for the K -user IC consists of $K - 1$ phases as follows:

Phase 1 (Full-duplex K -user IC with Delayed CSIT): In this phase, fresh information symbols are fed to the channel as follows: For every subset $\mathcal{S}_3 = \{i_1, i_2, i_3\} \subseteq \mathcal{S}_K$, spend 3 time slots to transmit 6 *fresh* information symbols $\{u_1^{[i_1]}, u_2^{[i_1]}, u_1^{[i_2]}, u_2^{[i_2]}, u_1^{[i_3]}, u_2^{[i_3]}\}$ by $\{\text{TX}_{i_1}, \text{TX}_{i_2}, \text{TX}_{i_3}\}$ as follows:

In the first time slot, TX_{i_1} and TX_{i_2} transmit $u_1^{[i_1]}$ and $u_1^{[i_2]}$, respectively, the rest of transmitters are silent. Hence, ignoring the noise, RX_{i_1} and RX_{i_2} each receive one linear equation in terms of $u_1^{[i_1]}$ and $u_1^{[i_2]}$ by the end of the first time slot. Therefore, if we deliver a linearly independent equation in terms of $u_1^{[i_1]}$ and $u_1^{[i_2]}$ to both RX_{i_1} and RX_{i_2} , each of them will be able to decode both transmitted symbols (desired and interference). This linearly independent equation is indeed the linear combination $h^{[i_3 i_1]}(1)u_1^{[i_1]} + h^{[i_3 i_2]}(1)u_1^{[i_2]}$ received by RX_{i_3} during this time slot. On the other hand, according to full-duplex operation of the transmitters, both TX_{i_1} and TX_{i_2} will have both $u_1^{[i_1]}$ and $u_1^{[i_2]}$ by the end of the first time slot. This along with the delayed CSIT assumption enables both TX_{i_1} and TX_{i_2} to reconstruct $h^{[i_3 i_1]}(1)u_1^{[i_1]} + h^{[i_3 i_2]}(1)u_1^{[i_2]}$. Thus, according to Notation 7, one can define

$$u^{[i_1, i_2 | i_1, i_2; i_3]} \triangleq h^{[i_3 i_1]}(1)u_1^{[i_1]} + h^{[i_3 i_2]}(1)u_1^{[i_2]}. \quad (4.39)$$

Similarly, the second and third time slots are described as follows:

- *Second time slot:* TX_{i_2} and TX_{i_3} transmit $u_2^{[i_2]}$ and $u_1^{[i_3]}$, respectively. The symbol $u^{[i_2, i_3 | i_2, i_3; i_1]}$ will be accordingly generated after this time slot.
- *Third time slot:* TX_{i_3} and TX_{i_1} transmit $u_2^{[i_3]}$ and $u_2^{[i_1]}$, respectively. The symbol $u^{[i_3, i_1 | i_3, i_1; i_2]}$ will be accordingly generated after this time slot.

CHAPTER 4: FULL-DUPLEX TX COOPERATION AND FEEDBACK

Therefore, $6\binom{K}{3}$ information symbols are transmitted in $3\binom{K}{3}$ time slots and $3\binom{K}{3}$ symbols of type $u^{[\mathcal{S}_2|\mathcal{S}_2;j]}$, $j \in \mathcal{S}_K \setminus \mathcal{S}_2$, are generated by the end of phase 1. We denote by $\underline{\text{DoF}}_m^{\text{ICFD}}(K)$, $2 \leq m \leq K - 1$, our achievable DoF for transmission of symbols of type $u^{[\mathcal{S}_m|\mathcal{S}_m;j]}$, $j \in \mathcal{S}_K \setminus \mathcal{S}_m$, over the K -user IC with full-duplex delayed CSIT. The achieved DoF is then calculated as

$$\underline{\text{DoF}}_1^{\text{ICFD}}(K) = \frac{6\binom{K}{3}}{3\binom{K}{3} + \frac{3\binom{K}{3}}{\underline{\text{DoF}}_2^{\text{ICFD}}(K)}} = \frac{2}{1 + \frac{1}{\underline{\text{DoF}}_2^{\text{ICFD}}(K)}}. \quad (4.40)$$

Phase m , $2 \leq m \leq K - 2$ (Full-duplex K -user IC with Delayed CSIT): For $m, n \in \mathbb{Z}$, define

$$L_m(n) \triangleq \text{lcm}\{n - m, m\} \quad (4.41)$$

$$Q_m(n) \triangleq \min\{n - m, m\}, \quad (4.42)$$

where $\text{lcm}\{x, y\}$, $x, y \in \mathbb{Z}$, is the least common multiplier of x and y . This phase takes $\frac{m+1}{m}\alpha_m(K)$ symbols $u^{[\mathcal{S}_m|\mathcal{S}_m;j]}$, $j \in \mathcal{S}_K \setminus \mathcal{S}_m$, transmits them over the channel in $\frac{\alpha_m(K)}{Q_m(K)}$ time slots, and generates $\frac{Q_m(K)-1}{Q_m(K)}\alpha_m(K)$ symbols of type $u^{[\mathcal{S}_{m+1}|\mathcal{S}_{m+1};j]}$, $j \in \mathcal{S}_K \setminus \mathcal{S}_{m+1}$, where $\alpha_m(K)$ is defined as

$$\alpha_m(K) \triangleq \binom{K}{m+1} \binom{K-m-1}{Q_m(K)-1} L_m(K). \quad (4.43)$$

Fix a subset $\mathcal{S}_{m+1} = \{i_1, i_2, \dots, i_{m+1}\} \subset \mathcal{S}_K$, and a subset $\mathcal{S}_{Q_m(K)-1} \subseteq \mathcal{S}_K \setminus \mathcal{S}_{m+1}$. During $\frac{L_m(K)}{Q_m(K)}$ time slots, each TX $_{i_n}$, $1 \leq n \leq m+1$, transmits a random linear combination of $u_k^{[\mathcal{S}_{m+1} \setminus \{i_{n-1}\} | \mathcal{S}_{m+1} \setminus \{i_{n-1}\}; i_{n-1}]}$, $1 \leq k \leq L_m(K)/m$, (with $i_0 \triangleq i_{m+1}$) in each time slot. Therefore, a total of $(m+1)\frac{L_m(K)}{m}$ symbols are transmitted in $\frac{L_m(K)}{Q_m(K)}$ time slots. We note that the random coefficients of these linear combinations are generated offline and shared with all nodes. Now, the following observations are important:

- (i) RX $_j$, $j \in \mathcal{S}_{m+1}$, wishes to decode the $L_m(K)$ symbols $\{u_k^{[\mathcal{S}_{m+1} \setminus \{j\} | \mathcal{S}_{m+1} \setminus \{j\}; j]}\}_{k=1}^{L_m(K)/m}$, $j' \in \mathcal{S}_{m+1} \setminus \{j\}$. Since it has all the symbols $\{u_k^{[\mathcal{S}_{m+1} \setminus \{j\} | \mathcal{S}_{m+1} \setminus \{j\}; j]}\}_{k=1}^{L_m(K)/m}$, by canceling them, it will obtain $\frac{L_m(K)}{Q_m(K)}$ equations out of its received equations, solely in terms of its desired symbols.

CHAPTER 4: FULL-DUPLEX TX COOPERATION AND FEEDBACK

- (ii) TX_{*i*}, *i* ∈ \mathcal{S}_{m+1} , has all the transmitted symbols except for $\{u_k^{[\mathcal{S}_{m+1} \setminus \{i\} | \mathcal{S}_{m+1} \setminus \{i\}; i]}\}_{k=1}^{L_m(K)/m}$. According to the full-duplex operation, it will obtain $\frac{L_m(K)}{Q_m(K)}$ random linear combinations of these symbols after canceling its known symbols, and since $\frac{L_m(K)}{Q_m(K)} \geq \frac{L_m(K)}{m}$, it can decode all of them.
- (iii) RX_{*j'*}, *j'* ∈ $\mathcal{S}_{Q_m(K)-1}$, receives $\frac{L_m(K)}{Q_m(K)}$ linear equations in terms of all transmitted symbols. If we deliver these linear combinations to RX_{*j*}, *j* ∈ \mathcal{S}_{m+1} , it will be able to cancel its undesired part as argued in observation (i) and obtain $\frac{L_m(K)}{Q_m(K)}$ equations solely in terms of its desired symbols. On the other hand, in view of observation (ii) and according to the delayed CSIT assumption, TX_{*i*}, *i* ∈ \mathcal{S}_{m+1} , can reconstruct all these linear combinations by the end of the $\frac{L_m(K)}{Q_m(K)}$ time slots. Thus, the $\frac{L_m(K)}{Q_m(K)}$ linear combinations received by RX_{*j'*}, *j'* ∈ $\mathcal{S}_{Q_m(K)-1}$, are denoted by $\{u_k^{[\mathcal{S}_{m+1} | \mathcal{S}_{m+1}; j']}\}_{k=1}^{L_m(K)/Q_m(K)}$. After delivering these $(Q_m(K) - 1) \times \frac{L_m(K)}{Q_m(K)}$ symbols to RX_{*j*}, *j* ∈ \mathcal{S}_{m+1} , it will be provided with a total of $L_m(K)$ linear combinations in terms of its $L_m(K)$ desired symbols. Also, it is easy to show that these linear combinations are linearly independent almost surely, and hence, can be solved for the desired symbols.

Since there are $\binom{K}{m+1}$ choices of \mathcal{S}_{m+1} and $\binom{K-m-1}{Q_m(K)-1}$ choices of $\mathcal{S}_{Q_m(K)-1}$ for each \mathcal{S}_{m+1} , the achieved DoF equals

$$\begin{aligned} \underline{\text{DoF}}_m^{\text{ICFD}}(K) &= \frac{(m+1)\alpha_m(K)/m}{\frac{\alpha_m(K)}{Q_m(K)} + \frac{(Q_m(K)-1)\alpha_m(K)/Q_m(K)}{\underline{\text{DoF}}_{m+1}^{\text{ICFD}}(K)}} \\ &= \frac{m+1}{m} \times \frac{Q_m(K)}{1 + \frac{Q_m(K)-1}{\underline{\text{DoF}}_{m+1}^{\text{ICFD}}(K)}}, \quad 2 \leq m \leq K-2. \end{aligned} \quad (4.44)$$

Phase $K - 1$ (Full-duplex K -user IC with Delayed CSIT): During $K - 1$ consecutive time slots, TX_{*i*}, *i* ∈ \mathcal{S}_K , repeats the symbol $u^{[\mathcal{S}_K \setminus \{i-1\} | \mathcal{S}_K \setminus \{i-1\}; i-1]}$ (with $u^{[\mathcal{S}_K \setminus \{0\} | \mathcal{S}_K \setminus \{0\}; 0]} \triangleq u^{[\mathcal{S}_K \setminus \{K\} | \mathcal{S}_K \setminus \{K\}; K]}$). It is easily verified that, in each time slot, each receiver obtains a linear combination of its $K - 1$ desired symbols. Hence, after $K - 1$ time slots, every receiver will be able to decode all its $K - 1$ desired symbols. One then can write

$$\underline{\text{DoF}}_{K-1}^{\text{ICFD}}(K) = \frac{K}{K-1}. \quad (4.45)$$

At the end, following Appendix A.3, it can be shown that (4.31) is indeed the closed form solution to the recursive equations (4.40) and (4.44) with initial condition (4.45).

4.5.2 Proof of Theorem 8

For the general $M \times K$ SISO X channel, a K -phase transmission scheme is proposed wherein the information symbols are transmitted in the first phase towards generation of higher order symbols during the subsequent phases. The order- K symbols will be finally delivered to all receivers in phase K .

Phase 1 (Full-duplex $M \times K$ X Channel with Delayed CSIT): Fix $i_1, i_2 \in \mathcal{S}_M^{(t)}$. For any $\{j_1, j_2\} \in \mathcal{S}_K^{(r)}$, TX $_{i_1}$ and TX $_{i_2}$ transmit four *fresh* information symbols $u^{[i_1|j_1]}$, $u^{[i_2|j_1]}$, $u^{[i_1|j_2]}$, and $u^{[i_2|j_2]}$ in two time slots as follows (we have ignored the indices of symbols for ease of notations): over the first time slot, TX $_{i_1}$ and TX $_{i_2}$ respectively transmit $u^{[i_1|j_1]}$, $u^{[i_2|j_1]}$, both intended for RX $_{j_1}$. After this time slot, the linear combination $h^{[j_2i_1]}u^{[i_1|j_1]} + h^{[j_2i_2]}u^{[i_2|j_1]}$, which has been received by RX $_{j_2}$, is available at TX $_{i_1}$ and TX $_{i_2}$ due to full-duplex operation of the transmitters and delayed CSIT, and is desired by RX $_{j_1}$ to be able to decode $u^{[i_1|j_1]}$ and $u^{[i_2|j_1]}$. Hence, it is denoted as $u^{[i_1, i_2|j_1; j_2]}$. Similarly, over the second time slot, TX $_{i_1}$ and TX $_{i_2}$ respectively transmit $u^{[i_1|j_2]}$, $u^{[i_2|j_2]}$, both intended now for RX $_{j_2}$, and the symbol $u^{[i_1, i_2|j_2; j_1]}$ is generated. It is easily verified that $u^{[i_1, i_2|j_1; j_2]} + u^{[i_1, i_2|j_2; j_1]}$ is desired by both RX $_{j_1}$ and RX $_{j_2}$. Hence, one can define the following order-2 symbol:

$$u^{[i_1, i_2|j_1, j_2]} \triangleq u^{[i_1, i_2|j_1; j_2]} + u^{[i_1, i_2|j_2; j_1]}. \quad (4.46)$$

By the end of this phase, $4 \binom{M}{2} \binom{K}{2}$ fresh information symbols are transmitted in $2 \binom{M}{2} \binom{K}{2}$ time slots and $\binom{M}{2} \binom{K}{2}$ order-2 symbols are generated, which will be delivered to their corresponding pairs of receivers during the rest of the transmission scheme. The achieved DoF is then calculated as

$$\underline{\text{DoF}}_1^{\text{XFD}}(M, K) = \frac{4 \binom{M}{2} \binom{K}{2}}{2 \binom{M}{2} \binom{K}{2} + \frac{\binom{M}{2} \binom{K}{2}}{\underline{\text{DoF}}_2^{\text{XFD}}(M, K)}} = \frac{4}{2 + \frac{1}{\underline{\text{DoF}}_2^{\text{XFD}}(M, K)}}, \quad (4.47)$$

where $\underline{\text{DoF}}_2^{\text{XFD}}(M, K)$ denotes our achievable DoF for transmission of order-2 symbols of type $u^{[\mathcal{S}_2^{(t)}|\mathcal{S}_2^{(r)}]}$ over the full-duplex $M \times K$ SISO X channel with delayed CSIT.

Phase m , $2 \leq m \leq K - 1$ (Full-duplex $M \times K$ X Channel with Delayed CSIT):

Consider the following distinct cases:

- (i) $M > \frac{K}{2}$, $2 \leq m \leq \frac{K}{2}$:

In this case, order- m symbols of type $u^{[\mathcal{S}_m^{(t)}|\mathcal{S}_m^{(r)}]}$ are transmitted over the channel. Fix a subset $\mathcal{S}_{2m}^{(r)} \subseteq \mathcal{S}_K^{(r)}$, and a subset $\mathcal{S}_{m+1}^{(t)} = \{i_1, i_2, \dots, i_{m+1}\} \subseteq \mathcal{S}_M^{(t)}$. Note that since $m \leq K/2 < M$, both subsets exist. All transmitters TX_j , $j \in \mathcal{S}_M^{(t)} \setminus \mathcal{S}_{m+1}^{(t)}$, are silent, while the transmitters TX_{i_n} , $1 \leq n \leq m + 1$, simultaneously transmit as follows: For every subset $\mathcal{S}_m^{(r)} \subset \mathcal{S}_{2m}^{(r)}$, spend one time slot to transmit $u^{[i_n, i_{n+1}, \dots, i_{n+m-1}|\mathcal{S}_m^{(r)}]}$ by TX_{i_n} , $n = 1, \dots, m + 1$, where $i_k \triangleq i_{k-m-1}$ for $m + 1 < k \leq 2m$. Every RX_j , $j \in \mathcal{S}_m^{(r)}$, receives one linear equation in terms of $m + 1$ desired symbols, and thus, requires m extra independent equations to resolve all the $m + 1$ symbols. It is easy to see that the equation received by RX_j , $j \in \mathcal{S}_{2m}^{(r)} \setminus \mathcal{S}_m^{(r)}$, is linearly independent of the equation received by each RX_j , $j \in \mathcal{S}_m^{(r)}$, and hence, is desired by all of them. On the other hand, every TX_{i_n} , $1 \leq n \leq m + 1$, knows exactly m symbols out of the $m + 1$ transmitted symbols, and thus, obtains the last one using the full-duplex operation by the end of this time slot. Hence, TX_{i_n} , $1 \leq n \leq m + 1$, having access to all the $m + 1$ transmitted symbols and the delayed CSI, can reconstruct the linear combinations received by all receivers by the end of this time slot. In particular, one can denote the linear combination received by RX_j , $j \in \mathcal{S}_{2m}^{(r)} \setminus \mathcal{S}_m^{(r)}$, as $u^{[\mathcal{S}_{m+1}^{(t)}|\mathcal{S}_m^{(r)};j]}$.

Now, we have the following observation: For any subset $\mathcal{S}_{m+1}^{(r)} \subset \mathcal{S}_{2m}^{(r)}$, consider the $m + 1$ symbols $u^{[\mathcal{S}_{m+1}^{(t)}|\mathcal{S}_{m+1}^{(r)} \setminus \{j\};j]}$, $j \in \mathcal{S}_{m+1}^{(r)}$, as defined above. Each receiver RX_j , $j \in \mathcal{S}_{m+1}^{(r)}$, has exactly one of these symbols and requires the other m . Therefore, if we deliver m random linear combinations of these $m + 1$ symbols to all receivers RX_j , $j \in \mathcal{S}_{m+1}^{(r)}$, each of them will be provided with m random linear combinations of m desired unknowns, and thus, will resolve all of them. Hence, these m random linear combinations can be denoted as $\{u_k^{[\mathcal{S}_{m+1}^{(t)}|\mathcal{S}_{m+1}^{(r)}]}\}_{k=1}^m$. These order- $(m+1)$ symbols will be delivered to their corresponding receivers during the rest of the transmission scheme. We denote by $\text{DoF}_m^{\text{XFD}}(M, K)$, $2 \leq m \leq K/2 < M$, our achievable DoF for transmission of order- m symbols of type $u^{[\mathcal{S}_m^{(t)}|\mathcal{S}_m^{(r)}]}$ over the full-duplex $M \times K$ SISO X channel with delayed CSIT. Since there are $\binom{K}{2m}$ choices for $\mathcal{S}_{2m}^{(r)}$, $\binom{M}{m+1}$ choices for

CHAPTER 4: FULL-DUPLEX TX COOPERATION AND FEEDBACK

$\mathcal{S}_{m+1}^{(t)}$, and $\binom{2m}{m}$ choices for $\mathcal{S}_m^{(r)}$, the achieved DoF is calculated as

$$\begin{aligned} \text{DoF}_m^{\text{XFD}}(M, K) &= \frac{\binom{M}{m+1} \binom{K}{2m} \binom{2m}{m} (m+1)}{\binom{M}{m+1} \binom{K}{2m} \binom{2m}{m} + \frac{\binom{M}{m+1} \binom{K}{2m} \binom{2m}{m+1} m}{\text{DoF}_{m+1}^{\text{XFD}}(M, K)}} \\ &= \frac{(m+1)^2}{m+1 + \frac{m^2}{\text{DoF}_{m+1}^{\text{XFD}}(M, K)}}, \quad M > \frac{K}{2}, \quad 2 \leq m \leq \frac{K}{2}. \end{aligned} \quad (4.48)$$

(ii) $M > \frac{K}{2}$, $\frac{K}{2} < m \leq K-1$:

In this case, order- m symbols of type $u^{\lfloor \mathcal{S}_{\lfloor K/2 \rfloor + 1}^{(t)} | \mathcal{S}_m^{(r)} \rfloor}$ are transmitted over the channel. Since $K/2 < M$ and $K/2 < m$, we have $K - m + 1 \leq \lfloor K/2 \rfloor + 1 \leq M$. Fix a subset $\mathcal{S}_{\lfloor K/2 \rfloor + 1}^{(t)} \subseteq \mathcal{S}_M^{(t)}$ of transmitters. For every subset $\mathcal{S}_m^{(r)} \subset \mathcal{S}_K^{(r)}$ of receivers, spend one time slot to simultaneously transmit $K - m + 1$ symbols $\{u_k^{\lfloor \mathcal{S}_{\lfloor K/2 \rfloor + 1}^{(t)} | \mathcal{S}_m^{(r)} \rfloor}\}_{k=1}^{K-m+1}$ by $K - m + 1$ arbitrary transmitters out of the $\lfloor K/2 \rfloor + 1$ transmitters. Then, each of the m receivers in $\mathcal{S}_m^{(r)}$ will receive one linear combination in terms of the $K - m + 1$ desired transmitted symbols. Hence, each of them requires $K - m$ more linearly independent combinations to resolve all the transmitted symbols. Therefore, the linear combinations received by the $K - m$ receivers in $\mathcal{S}_K^{(r)} \setminus \mathcal{S}_m^{(r)}$ will be desired by every receiver in $\mathcal{S}_m^{(r)}$. On the other hand, these linear combinations will be available at every transmitter in $\mathcal{S}_{\lfloor K/2 \rfloor + 1}^{(t)}$ by the delayed CSIT assumption (the transmitters do not use their full-duplex capability in this case). Thus, one can denote them as $u^{\lfloor \mathcal{S}_{\lfloor K/2 \rfloor + 1}^{(t)} | \mathcal{S}_m^{(r)} : j \rfloor}$, $j \in \mathcal{S}_K^{(r)} \setminus \mathcal{S}_m^{(r)}$.

To deliver these generated side information symbols to their respective subsets of receivers, one can make a similar observation as in case (i). In particular, for every subset $\mathcal{S}_{m+1}^{(r)} \subseteq \mathcal{S}_K^{(r)}$ of $m+1$ receivers, m random linear combinations of the symbols $u^{\lfloor \mathcal{S}_{\lfloor K/2 \rfloor + 1}^{(t)} | \mathcal{S}_{m+1}^{(r)} \setminus \{j\} : j \rfloor}$, $j \in \mathcal{S}_{m+1}^{(r)}$, will be desired by each receiver in $\mathcal{S}_{m+1}^{(r)}$, and hence, can be denoted as $\{u_k^{\lfloor \mathcal{S}_{\lfloor K/2 \rfloor + 1}^{(t)} | \mathcal{S}_{m+1}^{(r)} \rfloor}\}_{k=1}^m$. These order- $(m+1)$ symbols are the inputs of the next phase of transmission scheme. Finally, the achieved DoF of this phase satisfies the following recursion:

$$\begin{aligned}
 \underline{\text{DoF}}_m^{\text{XFD}}(M, K) &= \frac{\binom{M}{\lfloor K/2 \rfloor + 1} \binom{K}{m} (K - m + 1)}{\binom{M}{\lfloor K/2 \rfloor + 1} \binom{K}{m} + \frac{\binom{M}{\lfloor K/2 \rfloor + 1} \binom{K}{m+1} m}{\underline{\text{DoF}}_{m+1}^{\text{XFD}}(M, K)}} \\
 &= \frac{(m+1)(K-m+1)}{m+1 + \frac{m(K-m)}{\underline{\text{DoF}}_{m+1}^{\text{XFD}}(M, K)}}, \quad M > \frac{K}{2}, \quad \frac{K}{2} < m \leq K-1.
 \end{aligned} \tag{4.49}$$

(iii) $2 \leq M \leq \frac{K}{2}$, $2 \leq m < M$:

In this case, order- m symbols of type $u^{[\mathcal{S}_m^{(t)} | \mathcal{S}_m^{(r)}]}$ are transmitted over the channel. Since in this case we have $m < M \leq K/2$, the transmission scheme proposed for case (i) works for this case as well and the achieved DoF is given by (4.48).

(iv) $2 \leq M \leq \frac{K}{2}$, $M \leq m \leq K-1$:

In this case, order- m symbols of type $u^{[\mathcal{S}_M^{(t)} | \mathcal{S}_m^{(r)}]}$ are transmitted over the channel without operating in the full-duplex mode. The scheme is very similar to the scheme proposed in case (ii), except that here we have $\mathcal{S}_M^{(t)}$ instead of $\mathcal{S}_{\lfloor K/2 \rfloor + 1}^{(t)}$. Also, for every subset $\mathcal{S}_m^{(r)} \subset \mathcal{S}_K^{(r)}$ of receivers, here we spend one time slot to simultaneously transmit $\min\{M-1, K-m\} + 1$ symbols of type $u^{[\mathcal{S}_M^{(t)} | \mathcal{S}_m^{(r)}]}$ (as opposed to case (ii) where $K-m+1$ symbols were transmitted). It can be similarly shown that the following DoF is achievable in this case

$$\underline{\text{DoF}}_m^{\text{XFD}}(M, K) = \frac{(m+1)(\min\{M-1, K-m\} + 1)}{m+1 + \frac{m \times \min\{M-1, K-m\}}{\underline{\text{DoF}}_{m+1}^{\text{XFD}}(M, K)}}, \quad M \leq \frac{K}{2}, \quad M \leq m \leq K-1, \tag{4.50}$$

where $\underline{\text{DoF}}_m^{\text{XFD}}(M, K)$ (resp. $\underline{\text{DoF}}_{m+1}^{\text{XFD}}(M, K)$) denotes our achievable DoF for transmission of symbols of type $u^{[\mathcal{S}_m^{(t)} | \mathcal{S}_m^{(r)}]}$ (resp. $u^{[\mathcal{S}_M^{(t)} | \mathcal{S}_{m+1}^{(r)}]}$) over the full-duplex $M \times K$ SISO X channel with delayed CSIT.

To summarize our achievable results for the above cases, for $m, M, K \in \mathbb{Z}$, we define

$$Q_m(M, K) \triangleq \min\{M-1, K-m, m\}, \tag{4.51}$$

$$\Theta_m(M, K) \triangleq \min\{M, \lfloor K/2 \rfloor + 1, m\}, \quad (4.52)$$

and denote by $\underline{\text{DoF}}_m^{\text{XFD}}(M, K)$ our achievable DoF for transmission of order- m symbols of type $u^{[\mathcal{S}_{\Theta_m(M, K)}^{(t)} | \mathcal{S}_m^{(r)}]}$ over the full-duplex $M \times K$ SISO X channel with delayed CSIT. Then, it is easy to see from (4.47) to (4.50) that our achievable DoF satisfies the following recursive equation:

$$\underline{\text{DoF}}_m^{\text{XFD}}(M, K) = \frac{(m+1)(Q_m(M, K) + 1)}{m+1 + \frac{m \times Q_m(M, K)}{\underline{\text{DoF}}_{m+1}^{\text{XFD}}(M, K)}}, \quad 1 \leq m \leq K-1. \quad (4.53)$$

Phase K (Full-duplex $M \times K$ X Channel with Delayed CSIT):

In this phase, the symbols of type $u^{[\mathcal{S}_{\Theta_K(M, K)}^{(t)} | \mathcal{S}_K^{(r)}]}$ are delivered to all K receivers by simple transmission of one symbol per time slot by one of the transmitters (which has access to that symbol). Therefore,

$$\underline{\text{DoF}}_K^{\text{XFD}}(M, K) = 1. \quad (4.54)$$

It is shown in Appendix A.4 that (4.32) is indeed the closed form solution to the recursive equation (4.53) together with the initial condition (4.54).

4.6 SISO Interference and X Channels with Output Feedback

In this section, we investigate the impact of output feedback on the DoF of the K -user IC and $K \times K$ X channel. As defined in Section 4.1, we assume that output of each receiver is fed back to its paired transmitter. This provides each transmitter with “some” information about the other transmitters’ messages, which enables the transmitters to cooperate in their subsequent transmissions. Recall that in our achievable schemes for the full-duplex IC and X channel with delayed CSIT, described in Section 4.5, each transmitter acquired *pure* symbols of the other transmitters via full-duplex cooperation in order to *reconstruct* the linear combinations received by the receivers. The number of simultaneously active

CHAPTER 4: FULL-DUPLEX TX COOPERATION AND FEEDBACK

transmitters was restricted in each time slot such that each active transmitter can obtain a pure symbol transmitted by one of the others. For instance, in phase 1 of the scheme, only two transmitters per time slot were allowed to simultaneously transmit over the channel. In contrast, when the output feedback is available, the linear combination received by each receiver will become readily available at one of the transmitters, and thus, the restriction on the number of simultaneously active transmitters is relaxed, providing for a higher level of transmitter cooperation and interference alignment. The rest of this section presents proofs of Theorems 9 and 10.

4.6.1 Proof of Theorem 9

Our transmission scheme for the K -user IC with output feedback consists of $K - \mu(K) + 1$ phases as follows, where the integer $\mu(K)$, $2 \leq \mu(K) \leq \lceil K/2 \rceil$, will be determined later:

Phase 1 (K -user IC with Output Feedback): For every subset $\mathcal{S}_{\mu(K)} \subset \mathcal{S}_K$, and every subset $\mathcal{S}_{\mu(K)-1} \subseteq \mathcal{S}_K \setminus \mathcal{S}_{\mu(K)}$, in one time slot, each TX_i , $i \in \mathcal{S}_{\mu(K)}$, transmits a *fresh* information symbol $u^{[i]}$. Then, if we deliver $\mu(K) - 1$ linearly independent combinations of the $\mu(K)$ transmitted symbols to RX_i , $i \in \mathcal{S}_{\mu(K)}$, it will be able to decode all the transmitted symbols. Thus, the equation received by RX_j , $j \in \mathcal{S}_{\mu(K)-1}$, which will be available at TX_j via the output feedback, is desired by all the receivers RX_i , $i \in \mathcal{S}_{\mu(K)}$. Hence, they can be denoted as $u^{[j|\mathcal{S}_{\mu(K):j}]}$, $j \in \mathcal{S}_{\mu(K)-1}$.

Therefore, $\mu(K) \binom{K}{\mu(K)} \binom{K-\mu(K)}{\mu(K)-1}$ information symbols are transmitted in $\binom{K}{\mu(K)} \binom{K-\mu(K)}{\mu(K)-1}$ time slots and $(\mu(K) - 1) \binom{K}{\mu(K)} \binom{K-\mu(K)}{\mu(K)-1}$ symbols $u^{[j|\mathcal{S}_{\mu(K):j}]}$ are generated by the end of phase 1. Denoting by $\underline{\text{DoF}}_m^{\text{ICOF}}(K)$ our achievable DoF for transmission of symbols $u^{[j|\mathcal{S}_m:j]}$, $j \in \mathcal{S}_K \setminus \mathcal{S}_m$, over the K -user IC with output feedback, the achieved DoF is equal to

$$\underline{\text{DoF}}_1^{\text{ICOF}}(K) = \frac{\mu(K)}{1 + \frac{\mu(K)-1}{\underline{\text{DoF}}_{\mu(K)}^{\text{ICOF}}(K)}}. \quad (4.55)$$

Phase m , $2 \leq m \leq K - 2$ (K -user IC with Output Feedback): This phase feeds $\frac{m+1}{m} \alpha_m(K)$ symbols of type $u^{[j|\mathcal{S}_m:j]}$, $j \in \mathcal{S}_K \setminus \mathcal{S}_m$, to the channel in $\frac{\alpha_m(K)}{Q_m(K)}$ time

CHAPTER 4: FULL-DUPLEX TX COOPERATION AND FEEDBACK

slots, and generates $\frac{Q_m(K)-1}{Q_m(K)}\alpha_m(K)$ symbols of type $u^{[j|\mathcal{S}_{m+1};j]}$, $j \in \mathcal{S}_K \setminus \mathcal{S}_{m+1}$. In specific, for every subset $\mathcal{S}_{m+1} \subset \mathcal{S}_K$, and every subset $\mathcal{S}_{Q_m(K)-1} \subseteq \mathcal{S}_K \setminus \mathcal{S}_{m+1}$, during $\frac{L_m(K)}{Q_m(K)}$ time slots, every TX_i , $i \in \mathcal{S}_{m+1}$, transmits $\frac{L_m(K)}{Q_m(K)}$ random linear combinations of symbols $\{u_k^{[i|\mathcal{S}_{m+1} \setminus \{i\};i]}\}_{k=1}^{L_m(K)/m}$. Each RX_j , $j \in \mathcal{S}_{m+1}$, wishes to decode the $L_m(K)$ symbols $\{u_k^{[j'|\mathcal{S}_{m+1} \setminus \{j\};j']}\}_{k=1}^{L_m(K)/m}$, $j' \in \mathcal{S}_{m+1} \setminus \{j\}$. Also, RX_j , $j \in \mathcal{S}_{m+1}$, after removing $u_k^{[j|\mathcal{S}_{m+1} \setminus \{j\};j]}$, $k = 1, \dots, L_m(K)/m$, from its received equations, obtains $\frac{L_m(K)}{Q_m(K)}$ linear equations solely in terms of its desired symbols. If we deliver the $\frac{L_m(K)}{Q_m(K)}$ linear equations received by $\text{RX}_{j'}$, $j' \in \mathcal{S}_{Q_m(K)-1}$, to RX_j , $j \in \mathcal{S}_{m+1}$, it will obtain another $(Q_m(K) - 1) \times \frac{L_m(K)}{Q_m(K)}$ linear equations solely in terms of its desired symbols. Since these equations will be available at $\text{TX}_{j'}$, $j' \in \mathcal{S}_{Q_m(K)-1}$, via the output feedback, they are denoted as $\{u_k^{[j'|\mathcal{S}_{m+1};j']}\}_{k=1}^{L_m(K)/Q_m(K)}$. Therefore, RX_j , $j \in \mathcal{S}_{m+1}$, will have $L_m(K)$ (linearly independent) equations in terms of its $L_m(K)$ desired symbols, and can solve them for its desired symbols.

Finally, since the number of input symbols, spent time slots, and output symbols of this phase are equal to those of phase m in the proposed transmission scheme for the full-duplex K -user IC with delayed CSIT described in proof of Theorem 7, the achieved DoF for phase m satisfies the same recursive equation, i.e., (4.44):

$$\underline{\text{DoF}}_m^{\text{ICOF}}(K) = \frac{m+1}{m} \times \frac{Q_m(K)}{1 + \frac{Q_m(K)-1}{\underline{\text{DoF}}_{m+1}^{\text{ICOF}}(K)}}, \quad 2 \leq m \leq K-2. \quad (4.56)$$

Phase $K-1$ (K -user IC with Output Feedback): During $K-1$ consecutive time slots, TX_i , $i \in \mathcal{S}_K$, repeats the symbol $u^{[i|\mathcal{S}_K \setminus \{i\};i]}$. Therefore, each receiver receives $K-1$ linear combination of its $K-1$ desired symbols, and thus, will be able to decode all its $K-1$ desired symbols. Hence,

$$\underline{\text{DoF}}_{K-1}^{\text{ICOF}} = \frac{K}{K-1}. \quad (4.57)$$

It is shown in Appendix A.3 that the solution to recursive equation (4.56) with initial condition (4.57) is given by

$$\underline{\text{DoF}}_m^{\text{ICOF}}(K) = \begin{cases} \left(\frac{1}{2} - \frac{m(m-1)}{2\lceil \frac{K}{2} \rceil (\lceil \frac{K}{2} \rceil - 1)} + \frac{m(m-1)}{\lfloor \frac{K}{2} \rfloor (\lfloor \frac{K}{2} \rfloor - 1)} \sum_{\ell=\lceil \frac{K}{2} \rceil + 1}^K \frac{1}{\ell} \right)^{-1}, & 2 \leq m \leq \lceil \frac{K}{2} \rceil \\ \left(\frac{m}{K-m} \sum_{\ell=m+1}^K \frac{1}{\ell} \right)^{-1}, & \lceil \frac{K}{2} \rceil < m \leq K-1 \end{cases}. \quad (4.58)$$

CHAPTER 4: FULL-DUPLEX TX COOPERATION AND FEEDBACK

Substituting (4.58) for $\underline{\text{DoF}}_{\mu(K)}^{\text{ICOF}}(K)$ in (4.55), we get

$$\underline{\text{DoF}}_1^{\text{ICOF}}(K) = \frac{\mu(K)}{a(K)\mu(K) (\mu(K) - 1)^2 + (\mu(K) + 1)/2}, \quad (4.59)$$

where $a(K)$ is defined by (4.35). Now, we choose $\mu(K)$ such that $\underline{\text{DoF}}_1^{\text{ICOF}}(K)$ given in (4.59) is maximized. In other words,

$$\mu(K) = \arg \max_{\substack{2 \leq w \leq \lceil K/2 \rceil \\ w \in \mathbb{Z}^+}} f_K^{\text{ICOF}}(w), \quad (4.60)$$

where $f_K^{\text{ICOF}}(w)$ is defined as

$$f_K^{\text{ICOF}}(w) \triangleq \frac{w}{a(K)w(w-1)^2 + (w+1)/2}. \quad (4.61)$$

By taking the derivative of $f_K^{\text{ICOF}}(w)$ with respect to w , it can be shown that the solution w_K^* to the maximization problem $w_K^* = \arg \max_{2 \leq w \leq \lceil K/2 \rceil} f_K^{\text{ICOF}}(w)$ is given by (4.34). Thus, since $f_K^{\text{ICOF}}(w)$ is a continuous and concave function of w , the solution $\mu(K)$ to the maximization problem (4.60) is either $\lfloor w_K^* \rfloor$ or $\lceil w_K^* \rceil$, depending on which yields a greater $f_K^{\text{ICOF}}(w)$, i.e.,

$$\mu(K) = \arg \max_{w \in \{\lfloor w_K^* \rfloor, \lceil w_K^* \rceil\}} f_K^{\text{ICOF}}(w), \quad (4.62)$$

which in view of (4.59) and (4.61) completes the proof. Figure 4.9 shows the achievable DoF for different values of $\mu(K)$ together with the optimized achievable DoF, i.e., $\underline{\text{DoF}}_1^{\text{ICOF}}(K)$, for $3 \leq K \leq 30$.

4.6.2 Proof of Theorem 10

We propose a transmission scheme which consists of 2 main phases as follows:

Phase 1 ($K \times K$ X Channel with Output Feedback): For every $j \in \mathcal{S}_K$, spend one time slot to transmit the fresh information symbols $u^{[1|j]}$, $u^{[2|j]}$, \dots , $u^{[K|j]}$ respectively by $\text{TX}_1, \text{TX}_2, \dots, \text{TX}_K$, all intended for RX_j . By the end of this time slot, RX_j has received one linear combination of all K desired symbols. Therefore, if the linear combinations

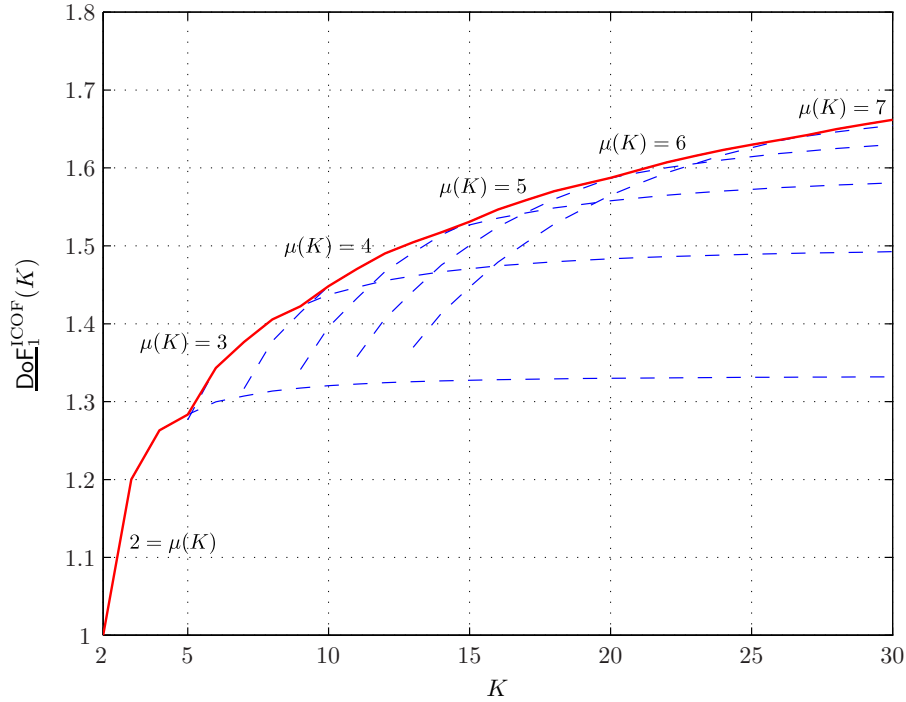

Figure 4.9: Achievable DoFs for the K -user IC with output feedback.

received by $\text{RX}_{j'}$, $j' \in \mathcal{S}_K \setminus \{j\}$, are delivered to RX_j , it can decode all the K symbols. On the other hand, according to the output feedback, the linear combination received by $\text{RX}_{j'}$, $j' \in \mathcal{S}_K \setminus \{j\}$, will be available at $\text{TX}_{j'}$ after this time slot. Hence, they can be denoted as $u^{[j':j:j']}$, $j' \in \mathcal{S}_K \setminus \{j\}$. Therefore, after K time slots, $K(K-1)$ symbols $u^{[j':j:j']}$, $j \in \mathcal{S}_K$, $j' \in \mathcal{S}_K \setminus \{j\}$, will be generated. These symbols will be delivered to their respective receiver during the next phase.

Phase 2 ($K \times K$ X Channel with Output Feedback): This phase takes $K(K-1)/2$ time slots to deliver the $K(K-1)$ symbols generated in phase 1 as follows: For any subset $\{j, j'\} \subseteq \mathcal{S}_K$, spend one time slot to transmit $u^{[j:j':j]}$ and $u^{[j':j:j']}$ by TX_j and $\text{TX}_{j'}$, respectively, while the other transmitters are silent. After this time slot, each of RX_j and $\text{RX}_{j'}$ can decode its desired symbol by canceling the interference symbol which it already has. The achieved DoF is then equal to

$$\underline{\text{DoF}}_1^{\text{XOF}}(K, K) = \frac{K^2}{K + K(K-1)/2} = \frac{2K}{K+1}, \quad (4.63)$$

completing the proof.

4.7 SISO Interference and X Channels with Shannon Feedback

With Shannon feedback, each transmitter has access to *all* observations made by its paired receiver, i.e., the channel output and all the channel coefficients, with some delay. Moreover, it has access to its own transmitted symbols. If a receiver wants to decode, say, n symbols (some of which might be interference), it requires n linearly independent equations in terms of the n symbols. However, the key observation is that after delivering $n - 1$ required equations to a receiver, its paired transmitter having access to Shannon feedback and its own transmitted symbol (which is one of the n symbols), will be able to decode all the remaining $n - 1$ symbols. Then, using the delayed CSIT, it will be able to reconstruct the last (yet undelivered) linear combination, and hence, to cooperate for its delivery. This allows for achieving higher DoFs compared to what we achieved in Sections 4.5 and 4.6. The following two subsections offer proofs of Theorems 11 and 12.

4.7.1 Proof of Theorem 11

Our achievable scheme for the K -user IC with Shannon feedback has two rounds of operation:

► *Round 1 (K -user IC with Shannon Feedback)*: In this round, the transmitters use only the output feedback in parallel with the scheme proposed in proof of Theorem 9. In specific, during phase 1, for every subset $\mathcal{S}_{\nu(K)} \subset \mathcal{S}_K$, every subset $\mathcal{S}_{\nu(K)-1} \subseteq \mathcal{S}_K \setminus \mathcal{S}_{\nu(K)}$, and every $j_0 \in \mathcal{S}_{\nu(K)-1}$, in one time slot, each TX_i , $i \in \mathcal{S}_{\nu(K)}$, transmits a *fresh* information symbol $u^{[i]}$. The integer $\nu(K)$, $2 \leq \nu(K) \leq \lceil K/2 \rceil$, will be determined later. The linear combination received by RX_j , $j \in \mathcal{S}_{\nu(K)-1}$, which will be available at TX_j via the output feedback, is desired by every RX_i , $i \in \mathcal{S}_{\nu(K)}$.

Now, TX_i , $i \in \mathcal{S}_{\nu(K)}$, using Shannon feedback and having $u^{[i]}$, obtains an equation in terms of the symbols $u^{[i']}$, $i' \in \mathcal{S}_{\nu(K)} \setminus \{i\}$. We deliver the $\nu(K) - 2$ linear combinations

CHAPTER 4: FULL-DUPLEX TX COOPERATION AND FEEDBACK

available at the receivers RX_j , $j \in \mathcal{S}_{\nu(K)-1} \setminus \{j_0\}$, to every RX_i , $i \in \mathcal{S}_{\nu(K)}$, using the scheme proposed in proof of Theorem 9. Meanwhile, TX_i using Shannon feedback and having $u^{[i]}$, will obtain another $\nu(K) - 2$ linearly independent combinations of $u^{[i']}$, $i' \in \mathcal{S}_{\nu(K)} \setminus \{i\}$, and hence, can decode all of them. Thereby, it can reconstruct the linear combination available at RX_{j_0} , which is still required by every RX_i , $i \in \mathcal{S}_{\nu(K)}$. Hence, this linear combination will be denoted as $u^{[\mathcal{S}_{\nu(K)} \cup \{j_0\} | \mathcal{S}_{\nu(K)}; j_0]}$.

We note that, for every subset $\mathcal{S}_{\nu(K)+1} \subseteq \mathcal{S}_K$, and every subset $\mathcal{S}_{\nu(K)-2} \subseteq \mathcal{S}_K \setminus \mathcal{S}_{\nu(K)+1}$, we have generated $\nu(K) + 1$ symbols $u^{[\mathcal{S}_{\nu(K)+1} | \mathcal{S}_{\nu(K)+1} \setminus \{j_0\}; j_0]}$, $j_0 \in \mathcal{S}_{\nu(K)+1}$. Since every RX_i , $i \in \mathcal{S}_{\nu(K)+1}$, needs exactly $\nu(K)$ out of these $\nu(K) + 1$ symbols, $\nu(K)$ random linear combinations of these symbols are desired by each RX_i , $i \in \mathcal{S}_{\nu(K)+1}$, and can be denoted as $\{u_k^{[\mathcal{S}_{\nu(K)+1} | \mathcal{S}_{\nu(K)+1}]}\}_{k=1}^{\nu(K)}$. They will be delivered during round 2 of the transmission scheme. The achieved DoF is therefore given by

$$\begin{aligned} \underline{\text{DoF}}_1^{\text{ICSF}}(K) &= \frac{\nu(K)\beta(K)}{\beta(K) + \frac{(\nu(K)-2)\beta(K)}{\underline{\text{DoF}}_{\nu(K)}^{\text{ICOF}}(K)} + \frac{\binom{K}{\nu(K)+1} \binom{K-\nu(K)-1}{\nu(K)-2} \nu(K)}{\underline{\text{DoF}}_{\nu(K)+1}^{\text{ICSF}}(K)}} \\ &= \frac{\nu(K)}{1 + \frac{\nu(K)-2}{\underline{\text{DoF}}_{\nu(K)}^{\text{ICOF}}(K)} + \frac{\nu(K)}{(\nu(K)+1)\underline{\text{DoF}}_{\nu(K)+1}^{\text{ICSF}}(K)}}, \end{aligned} \quad (4.64)$$

where

$$\beta(K) \triangleq \binom{K}{\nu(K)} \binom{K-\nu(K)}{\nu(K)-1} (\nu(K)-1), \quad (4.65)$$

and $\underline{\text{DoF}}_m^{\text{ICSF}}(K)$ denotes our achievable DoF for transmission of the symbols of type $u^{[\mathcal{S}_m | \mathcal{S}_m]}$ over the K -user IC with Shannon feedback.

► *Round 2 (K -user IC with Shannon Feedback):* This round consists of $K - \nu(K)$ phases described as follows:

Phase m , $\nu(K) + 1 \leq m \leq K - 1$ (K -user IC with Shannon Feedback): In this phase, symbols of type $u^{[\mathcal{S}_m | \mathcal{S}_m]}$ are fed to the channel and symbols of type $u^{[\mathcal{S}_{m+1} | \mathcal{S}_{m+1}]}$ are generated as follows: Fix a subset $\mathcal{S}_{Q_m(K+1)+m-1} \subseteq \mathcal{S}_K$, where $Q_m(n)$, $n \in \mathbb{Z}$, is defined in (4.42). For any $\mathcal{S}_m \subset \mathcal{S}_{Q_m(K+1)+m-1}$, spend one time slot to transmit $\{u_k^{[\mathcal{S}_m | \mathcal{S}_m]}\}_{k=1}^{Q_m(K+1)}$ by $Q_m(K+1)$ arbitrary transmitters out of $\{\text{TX}_j : j \in \mathcal{S}_m\}$. Then, RX_j , $j \in \mathcal{S}_m$, requires

CHAPTER 4: FULL-DUPLEX TX COOPERATION AND FEEDBACK

$Q_m(K+1) - 1$ extra equations to resolve all the transmitted symbols. Thus, the linear combination received by $\text{RX}_{j'}$, $j' \in \mathcal{S}_{Q_m(K+1)+m-1} \setminus \mathcal{S}_m$, which will be available at $\text{TX}_{j'}$ via the output feedback, is desired by every RX_j , $j \in \mathcal{S}_m$. On the other hand, every TX_j , $j \in \mathcal{S}_m$, having access to all the transmitted symbols and delayed CSI, can reconstruct this linear combination. Therefore, it is denoted as $u^{[\mathcal{S}_m \cup \{j'\} | \mathcal{S}_m : j']}$.

Now, for any subset $\mathcal{S}_{m+1} \subseteq \mathcal{S}_{Q_m(K+1)+m-1}$, consider $m+1$ symbols $u^{[\mathcal{S}_{m+1} | \mathcal{S}_{m+1} \setminus \{j\} : j]}$, $j \in \mathcal{S}_{m+1}$. It is easy to see that m random linear combinations of these symbols are desired by each RX_i , $i \in \mathcal{S}_{m+1}$, and can be denoted as $\{u_k^{[\mathcal{S}_{m+1} | \mathcal{S}_{m+1}]}\}_{k=1}^m$. The achieved DoF equals

$$\begin{aligned} \underline{\text{DoF}}_m^{\text{ICSF}}(K) &= \frac{Q_m(K+1) \binom{Q_m(K+1)+m-1}{m} \binom{K}{Q_m(K+1)+m-1}}{\binom{K}{Q_m(K+1)+m-1} \binom{Q_m(K+1)+m-1}{m} + \frac{m \binom{Q_m(K+1)+m-1}{m+1} \binom{K}{Q_m(K+1)+m-1}}{\underline{\text{DoF}}_{m+1}^{\text{ICSF}}(K)}} \\ &= \frac{(m+1)Q_m(K+1)}{m+1 + \frac{m \times (Q_m(K+1)-1)}{\underline{\text{DoF}}_{m+1}^{\text{ICSF}}(K)}}, \quad 2 \leq m \leq K-1. \end{aligned} \quad (4.66)$$

Phase K (K -user IC with Shannon Feedback): In this phase, one symbol $u^{[\mathcal{S}_K | \mathcal{S}_K]}$ per time slot is transmitted by an arbitrary transmitter. Hence,

$$\underline{\text{DoF}}_K^{\text{ICSF}}(K) = 1. \quad (4.67)$$

It is shown in Appendix A.5 that the solution $\underline{\text{DoF}}_m^{\text{ICSF}}(K)$ to the recursive equation (4.66) with initial condition (4.67) is given by (4.37). Therefore, the proof is complete in view of (4.64) and the fact that $\nu(K)$ is chosen to maximize $\underline{\text{DoF}}_1^{\text{ICSF}}(K)$. The achievable DoF for different values of $\nu(K)$ and the optimized achieved DoF are plotted in Fig. 4.10 for $2 \leq K \leq 30$.

4.7.2 Proof of Theorem 12

Our transmission scheme for the $K \times K$ X channel with output feedback operates in 2 rounds:

► *Round 1 ($K \times K$ X Channel with Shannon Feedback):* This round has 2 phases in parallel with the scheme proposed in proof of Theorem 10 for the same channel with output

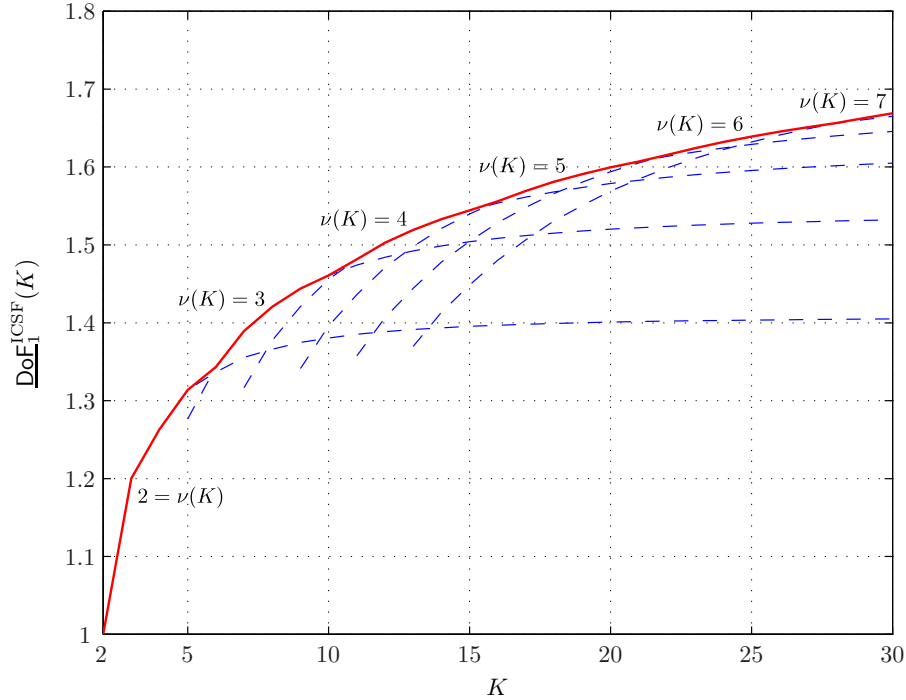
 Figure 4.10: Achievable DoFs for the K -user IC with Shannon feedback.

feedback. In particular, in phase 1, K^2 fresh information symbols $u^{[i|j]}$, $1 \leq i, j \leq K$, are transmitted over the channel during K time slots in the same way as the phase 1 of the scheme proposed in proof of Theorem 10, and $K(K-1)$ symbols $u^{[j'|j:j']}$, $\{j, j'\} \subseteq \mathcal{S}_K$, are generated correspondingly. After time slot j , TX_j , having access to its own transmitted symbol and Shannon feedback, will obtain a linear combination of the $K-1$ symbols $u^{[i|j]}$, $i \in \mathcal{S}_K \setminus \{j\}$. Therefore, if TX_j is provided with extra $K-2$ linearly independent combinations of these $K-1$ symbols (with known coefficients), it will be able to decode all of them.

In phase 2, the symbols $u^{[j'|j:j']}$ are transmitted in the same way as in the phase 2 of the scheme presented in proof of Theorem 10. However, here, according to the Shannon feedback, each TX_i obtains more linear combinations of the symbols $u^{[j|i]}$, $j \in \mathcal{S}_K \setminus \{i\}$, as we proceed with the transmissions. In specific, fix an index j_0 , $j_0 \in \mathcal{S}_K$. Then, for any $\{j, j'\} \in \mathcal{S}_K \setminus \{j_0\}$, spend one time slot to transmit $u^{[j|j':j]}$ and $u^{[j':j:j]}$ respectively by TX_j and $\text{TX}_{j'}$, while the other transmitters are silent. By the end of this time slot, $u^{[j|j':j]}$ and

CHAPTER 4: FULL-DUPLEX TX COOPERATION AND FEEDBACK

$u^{[j'|j;j']}$ are delivered to RX_j and $\text{RX}_{j'}$, respectively. Also, TX_j will obtain $u^{[j'|j;j']}$ through Shannon feedback, which is a linear combination of $u^{[i|j]}$, $i \in \mathcal{S}_K \setminus \{j\}$. Similarly, $\text{TX}_{j'}$ will obtain $u^{[j|j';j]}$ which is a linear combination of $u^{[i|j']}$, $i \in \mathcal{S}_K \setminus \{j'\}$. Therefore, one can verify that, after the $\binom{K-1}{2}$ time slots of this phase,

- (i) each RX_j , $j \in \mathcal{S}_K \setminus \{j_0\}$, will receive all the symbols $u^{[j'|j;j']}$, $j' \in \mathcal{S}_K \setminus \{j_0, j\}$;
- (ii) each TX_j , $j \in \mathcal{S}_K \setminus \{j_0\}$, will obtain $u^{[j'|j;j']}$, $j' \in \mathcal{S}_K \setminus \{j_0, j\}$, which are $K - 2$ linear combinations of the symbols $u^{[i|j]}$, $i \in \mathcal{S}_K \setminus \{j\}$. These linear combinations together with the linear combination obtained during phase 1, constitute $K - 1$ linearly independent combinations of $K - 1$ unknowns, and thus, can be solved for the symbols $u^{[i|j]}$, $i \in \mathcal{S}_K \setminus \{j\}$.

By observation (i), it only remains to deliver the $2(K - 1)$ symbols $u^{[j|j_0;j]}$, $u^{[j_0|j;j_0]}$, $j \in \mathcal{S}_K \setminus \{j_0\}$, to their respective receivers. On the other hand, by observation (ii), the symbol $u^{[j_0|j;j_0]}$, $j \in \mathcal{S}_K \setminus \{j_0\}$, can now be reconstructed by TX_j , and thus, can be denoted as $u^{[j,j_0|j;j_0]}$. Consequently, one can define the following order-2 symbol which is available at TX_j :

$$u^{[j|j,j_0]} \triangleq u^{[j|j_0;j]} + u^{[j,j_0|j;j_0]}, \quad j \in \mathcal{S}_K \setminus \{j_0\}. \quad (4.68)$$

Therefore, it only remains to deliver the above $K - 1$ order-2 symbols to their respective pairs of receivers. Before proceeding with the next round, we point out here that by K times repetition of phase 1, each time with K^2 fresh information symbols and a new j_0 , $1 \leq j_0 \leq K$, we will generate $K(K - 1)$ order-2 symbols $u^{[j|j,j_0]}$, $j_0 \in \mathcal{S}_K$, $j \in \mathcal{S}_K \setminus \{j_0\}$, as above. The achieved DoF will then be given by

$$\begin{aligned} \underline{\text{DoF}}_1^{\text{XSF}}(K, K) &= \frac{K \times K^2}{K \times K + K \times \binom{K-1}{2} + \frac{K \times (K-1)}{\underline{\text{DoF}}_2^{\text{XSF}}(K, K)}} \\ &= \frac{K^2}{K + \frac{(K-1)(K-2)}{2} + \frac{K-1}{\underline{\text{DoF}}_2^{\text{XSF}}(K, K)}}, \end{aligned} \quad (4.69)$$

where $\underline{\text{DoF}}_2^{\text{XSF}}(K, K)$ represents our achievable DoF for transmission of symbols $u^{[i|i,j]}$ and $u^{[j|i,j]}$, $\{i, j\} \subseteq \mathcal{S}_K$, over the $K \times K$ SISO X channel with Shannon feedback. These symbols will be delivered to their respective pairs of receivers during the next round.

CHAPTER 4: FULL-DUPLEX TX COOPERATION AND FEEDBACK

► *Round 2 ($K \times K$ X Channel with Shannon Feedback)*: This round has $K - 1$ phases (i.e., phases 2 to K). If $K = 2$, then the symbols $u^{[1|1,2]}$ and $u^{[2|1,2]}$ are transmitted respectively by TX₁ and TX₂ in 2 time slots, by the end of which both receivers will obtain both symbols. If $K > 2$, then the $K(K - 1)$ order-2 symbols of type $u^{[i|i,j]}$ and $u^{[j|i,j]}$, $\{i, j\} \subseteq \mathcal{S}_K$, are transmitted over the channel in phase 2 as follows: For each $\mathcal{S}_3 = \{i_1, i_2, i_3\} \subseteq \mathcal{S}_K$, spend three time slots to transmit $u^{[i_k|i_k, i_\ell]}$ and $u^{[i_\ell|i_k, i_\ell]}$, $\{k, \ell\} \subset \{1, 2, 3\}$. In specific, over the first time slot, $u^{[i_1|i_1, i_2]}$ and $u^{[i_2|i_1, i_2]}$ are respectively transmitted by TX _{i_1} and TX _{i_2} while the other transmitters are silent. Then, RX _{i_1} and RX _{i_2} each require an extra linear equation to decode both symbols. Hence, after this time slot, the linear combination $h^{[i_3 i_1]}u^{[i_1|i_1, i_2]} + h^{[i_3 i_2]}u^{[i_2|i_1, i_2]}$ received by RX _{i_3} , which is now available at TX _{i_3} via the output feedback, is desired by both RX _{i_1} and RX _{i_2} , where the time indices have been omitted for brevity. On the other hand, TX _{i_1} and TX _{i_2} having access to their own transmitted symbol and Shannon feedback, can decode each other's symbol. Therefore, using delayed CSIT, they can reconstruct $h^{[i_3 i_1]}u^{[i_1|i_1, i_2]} + h^{[i_3 i_2]}u^{[i_2|i_1, i_2]}$. Thus, we can define $u^{[\mathcal{S}_3|i_1, i_2; i_3]} \triangleq h^{[i_3 i_1]}u^{[i_1|i_1, i_2]} + h^{[i_3 i_2]}u^{[i_2|i_1, i_2]}$.

Similarly, the second and third time slots are dedicated respectively to transmission of $\{u^{[i_1|i_1, i_3]}, u^{[i_3|i_1, i_3]}\}$ and $\{u^{[i_2|i_2, i_3]}, u^{[i_3|i_2, i_3]}\}$, and generation of $u^{[\mathcal{S}_3|i_1, i_3; i_2]}$ and $u^{[\mathcal{S}_3|i_2, i_3; i_1]}$. Now, if we deliver two random linear combinations of $u^{[\mathcal{S}_3|i_1, i_2; i_3]}$, $u^{[\mathcal{S}_3|i_1, i_3; i_2]}$, and $u^{[\mathcal{S}_3|i_2, i_3; i_1]}$ to RX _{i_1} , RX _{i_2} , and RX _{i_3} , each of them will be able to decode its desired symbols. Therefore, we can define the following order-3 symbols:

$$u_1^{[\mathcal{S}_3|\mathcal{S}_3]} \triangleq \alpha_1 u^{[\mathcal{S}_3|i_2, i_3; i_1]} + \alpha_2 u^{[\mathcal{S}_3|i_1, i_3; i_2]} + \alpha_3 u^{[\mathcal{S}_3|i_1, i_2; i_3]}, \quad (4.70)$$

$$u_2^{[\mathcal{S}_3|\mathcal{S}_3]} \triangleq \alpha'_1 u^{[\mathcal{S}_3|i_2, i_3; i_1]} + \alpha'_2 u^{[\mathcal{S}_3|i_1, i_3; i_2]} + \alpha'_3 u^{[\mathcal{S}_3|i_1, i_2; i_3]}, \quad (4.71)$$

where $\alpha_k, \alpha'_k, k = 1, 2, 3$, are random coefficients. The achieved DoF is thus given by

$$\underline{\text{DoF}}_2^{\text{XSF}}(K, K) = \frac{6 \binom{K}{3}}{3 \binom{K}{3} + \frac{2 \binom{K}{3}}{\underline{\text{DoF}}_3^{\text{XSF}}(K, K)}} = \frac{6}{3 + \frac{2}{\underline{\text{DoF}}_3^{\text{XSF}}(K, K)}}, \quad (4.72)$$

where $\underline{\text{DoF}}_3^{\text{XSF}}(K, K)$ denotes our achievable DoF for transmission of symbols of type $u^{[\mathcal{S}_3|\mathcal{S}_3]}$ over the $K \times K$ SISO X channel with Shannon feedback.

Since the $K \times K$ SISO X channel has the same input-output relationship as the K -user SISO IC, the problem of transmission of order-3 symbols of type $u^{[\mathcal{S}_3|\mathcal{S}_3]}$ over the $K \times K$ X channel with Shannon feedback is equivalent to that of the IC with Shannon feedback. Hence, phase m , $3 \leq m \leq K$, of round 2 the scheme proposed in proof of Theorem 11 can be used for transmission of the order-3 symbols and generation of higher order symbols up to order- K symbols which will be delivered to all receivers in phase K . Therefore, the same recursive equation, i.e., (4.66), holds for $\underline{\text{DoF}}_m^{\text{XSF}}(K, K)$, $3 \leq m \leq K - 1$, with $\underline{\text{DoF}}_K^{\text{XSF}}(K, K) = 1$, and thus, $\underline{\text{DoF}}_m^{\text{XSF}}(K, K)$, $3 \leq m \leq K$, is given by (4.37). Finally, (4.38) results from (4.37), (4.69) and (4.72).

4.8 Comparison and Discussion

We compare the results of this chapter with achievable DoFs obtained in Chapter 3 for both channels with delayed CSIT. Figure 4.11 plots our achievable DoF for the K -user SISO IC with delayed CSIT and full-duplex transmitter cooperation, given by (4.31), together with our achievable DoFs for the K -user IC with output and Shannon feedback, respectively given by (4.33) and (4.36), and compares them with the achievable DoF for the same channel with delayed CSIT for $2 \leq K \leq 30$. It is seen from the figure that all our achievable DoFs for the K -user IC are strictly increasing in K , and for $K \geq 3$, they are greater than the achievable DoF for the same channel with delayed CSIT. Also, for $K \geq 6$, we achieve greater DoF with output feedback than with full-duplex delayed CSIT. Our achievable DoF with Shannon feedback is greater than that with output feedback for $K = 5$ and $K \geq 7$. One can also verify from (4.31) that

$$\lim_{K \rightarrow \infty} \underline{\text{DoF}}_1^{\text{ICFD}}(K) = \frac{4}{3}. \quad (4.73)$$

Regarding (4.34) and (4.35) and the fact that $\mu(K)$ is either $\lfloor w_K^* \rfloor$ or $\lceil w_K^* \rceil$, one can show $\mu(K) = o(K)$, which in view of (4.58) yields $\lim_{K \rightarrow \infty} \underline{\text{DoF}}_{\mu(K)}^{\text{ICOF}}(K) = 2$. This together with (4.55), and the fact that $\lim_{K \rightarrow \infty} \mu(K) = \infty$, implies that

$$\lim_{K \rightarrow \infty} \underline{\text{DoF}}_1^{\text{ICOF}}(K) = 2. \quad (4.74)$$

CHAPTER 4: FULL-DUPLEX TX COOPERATION AND FEEDBACK

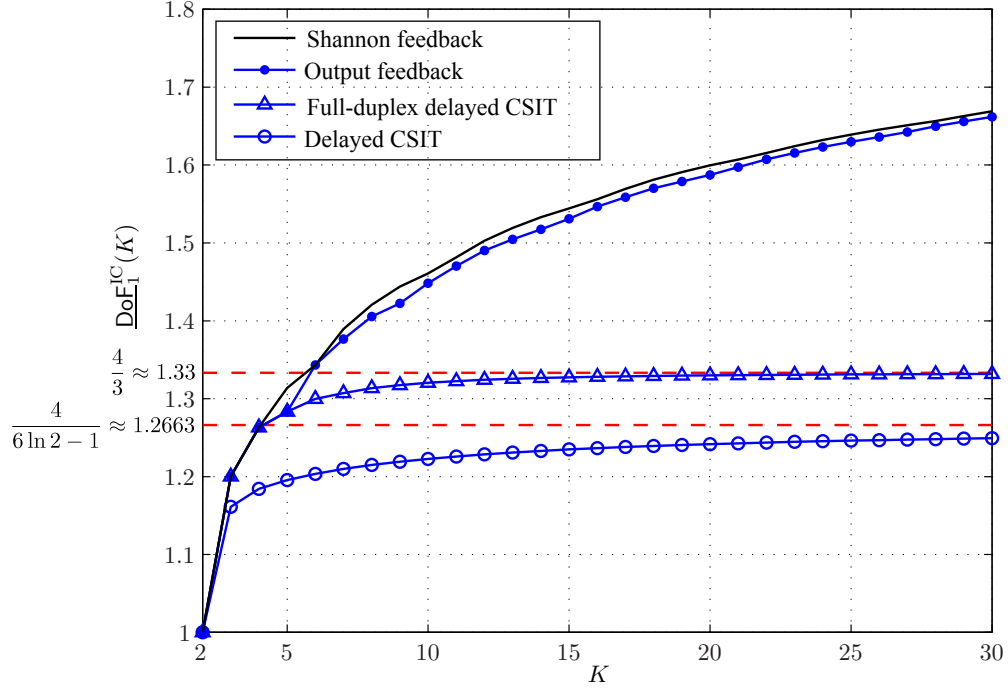

Figure 4.11: Achievable DoFs for the K -user IC with Shannon feedback, output feedback, full-duplex delayed CSIT, and delayed CSIT.

We now show that $\lim_{K \rightarrow \infty} \underline{\text{DoF}}_1^{\text{ICSF}}(K) = 2$. To do so, it suffices to show that $\underline{\text{DoF}}_1^{\text{ICSF}}(K) < 2$. An application of the Squeeze theorem regarding (4.74) and the fact that $\underline{\text{DoF}}_1^{\text{ICOF}}(K) \leq \underline{\text{DoF}}_1^{\text{ICSF}}(K)$ will then yield the desired result. Using (4.36), we have

$$\begin{aligned}
 \underline{\text{DoF}}_1^{\text{ICSF}}(K) &= \max_{\substack{2 \leq w \leq \lceil K/2 \rceil \\ w \in \mathbb{Z}^+}} \frac{w}{1 + \frac{w-2}{\underline{\text{DoF}}_w^{\text{ICOF}}(K)} + \frac{w}{(w+1)\underline{\text{DoF}}_{w+1}^{\text{ICSF}}(K)}} \\
 &< \max_{\substack{2 \leq w \leq \lceil K/2 \rceil \\ w \in \mathbb{Z}^+}} \frac{w}{1 + \frac{w-2}{\underline{\text{DoF}}_w^{\text{ICOF}}(K)}} \\
 &\stackrel{\text{(a)}}{=} \max_{\substack{2 \leq w \leq \lceil K/2 \rceil \\ w \in \mathbb{Z}^+}} \frac{1}{a(K)(w-1)(w-2) + \frac{1}{2}} \\
 &\stackrel{\text{(b)}}{=} 2,
 \end{aligned} \tag{4.75}$$

where (a) follows from (4.35) and (4.58), and (b) uses the fact that the denominator is strictly increasing in w for $w \geq 2$, and thus, is minimized at $w = 2$.

Figure 4.12 plots our achievable DoFs for the $M \times K$ SISO X channel with delayed

CHAPTER 4: FULL-DUPLEX TX COOPERATION AND FEEDBACK

CSIT and full-duplex transmitter cooperation, given by (4.32), for $M = 2, 3$, and $M > \frac{K}{2}$, and $2 \leq K \leq 30$, and compares them with the achievable DoF reported in [1] for the $2 \times K$ X channel with delayed CSIT. For all values of M , our achievable DoF for the full-duplex $M \times K$ X channel with delayed CSIT is strictly increasing in K and greater than that of the $2 \times K$ X channel with delayed CSIT. Also, it can be shown using (4.32) that for a fixed M :

$$\lim_{K \rightarrow \infty} \underline{\text{DoF}}_1^{\text{XFD}}(M, K) = \frac{1}{\sum_{\ell_1=2}^{M-2} \frac{1}{\ell_1^2} + \frac{1}{M-1} + \frac{1}{(M-1)^2} \left[\left(\frac{M}{M-1}\right)^{M-2} \ln M - \sum_{\ell_2=1}^{M-2} \left(\frac{M}{M-1}\right)^{M-2-\ell_2} \frac{1}{\ell_2} \right]}. \quad (4.76)$$

For instance, $\lim_{K \rightarrow \infty} \underline{\text{DoF}}_1^{\text{XFD}}(2, K) = \frac{1}{\ln 2}$ and $\lim_{K \rightarrow \infty} \underline{\text{DoF}}_1^{\text{XFD}}(3, K) = \frac{8}{3 \ln 3 + 2}$, as indicated in Fig. 4.12. Moreover, it follows from (4.32) and $\sum_{n=1}^{\infty} \frac{1}{n^2} = \frac{\pi^2}{6}$ that, if $M > K/2$ for sufficiently large K , then

$$\lim_{K \rightarrow \infty} \underline{\text{DoF}}_1^{\text{XFD}}(M, K) = \frac{6}{\pi^2 - 6}. \quad (4.77)$$

Figure 4.13 compares our achievable DoF for the $K \times K$ X channel with Shannon feedback (given by (4.38)), output feedback (which is $2K/(K+1)$ by Theorem 10), full-duplex delayed CSIT (given by (4.32)), and delayed CSIT [1] for $2 \leq K \leq 30$. It is observed that for $K > 2$,

$$\underline{\text{DoF}}_1^{\text{XFD}}(K, K) < \underline{\text{DoF}}_1^{\text{XOF}}(K, K) < \underline{\text{DoF}}_1^{\text{XSF}}(K, K). \quad (4.78)$$

Also, one can easily verify using (4.38) and $\underline{\text{DoF}}_1^{\text{XOF}}(K, K) = 2K/(K+1)$ that

$$\lim_{K \rightarrow \infty} \underline{\text{DoF}}_1^{\text{XOF}}(K, K) = \lim_{K \rightarrow \infty} \underline{\text{DoF}}_1^{\text{XSF}}(K, K) = 2. \quad (4.79)$$

4.9 Conclusion

We investigated the SISO Gaussian interference and X channels with arbitrary number of users, where we assumed that the CSI is not instantaneously available at the transmitters.

CHAPTER 4: FULL-DUPLEX TX COOPERATION AND FEEDBACK

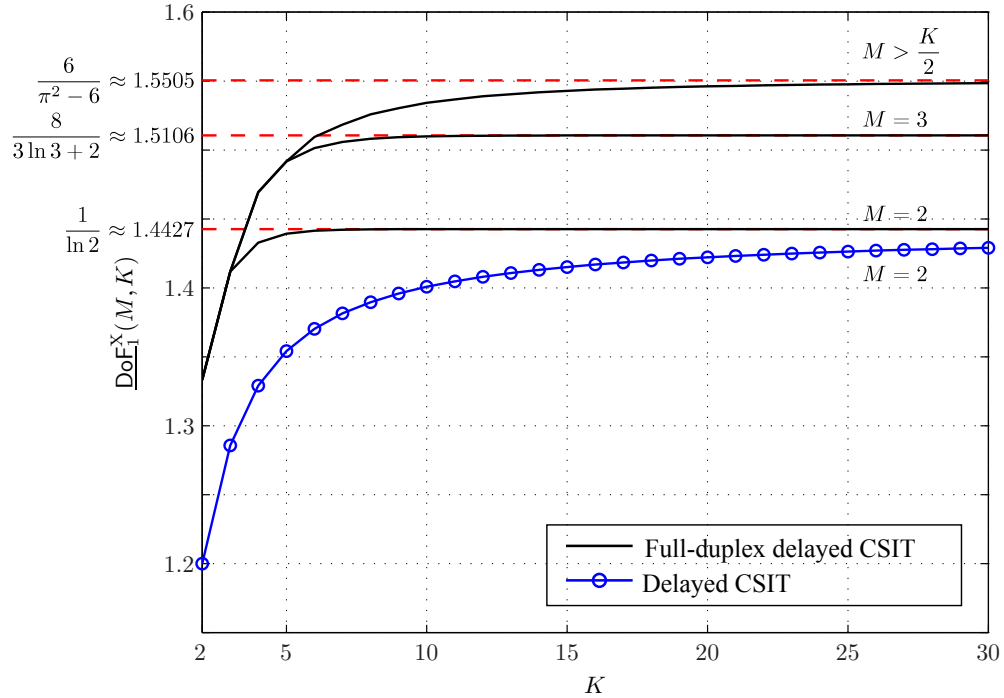

Figure 4.12: Achievable DoFs for the $M \times K$ X channel with delayed CSIT, with and without full-duplex transmitter cooperation.

We obtained achievable results on the DoF of these channels under three different assumptions, namely, *full-duplex delayed CSIT* (where the transmitters access the delayed CSI and can operate in full-duplex mode), *output feedback* (where each transmitter causally accesses the output of its paired receiver), and *Shannon feedback* (where each transmitter accesses both the output feedback and delayed CSI). Under each assumption, the transmitters, obtaining side information about each other's messages through full-duplex or feedback links, could cooperate to align the interference at the receivers in a multi-phase fashion.

For each channel, the transmitters enjoyed a different level of cooperation under each assumption, and hence, we achieved different values of DoF. Our achievable DoFs are greater than the best available achievable DoFs for both channels with delayed CSIT (cf. Chapter 3), and are strictly increasing with the number of receivers, though approaching limiting values not greater than 2 for asymptotically large networks. Our DoF results under the full-duplex delayed CSIT assumption are the first to demonstrate the potential

CHAPTER 4: FULL-DUPLEX TX COOPERATION AND FEEDBACK

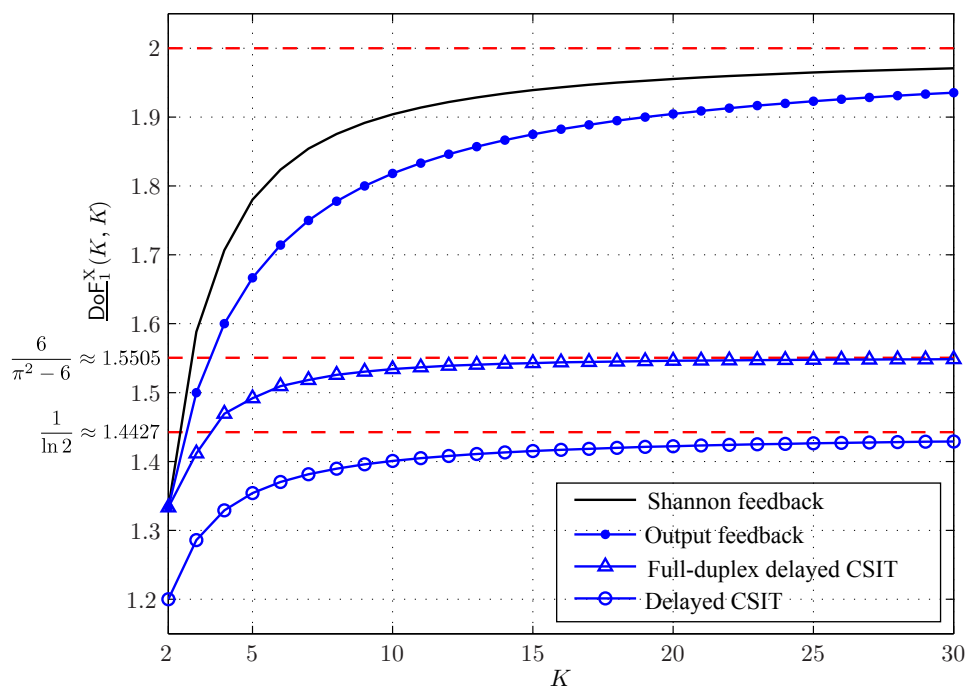

Figure 4.13: Achievable DoFs for the $K \times K$ X channel with Shannon feedback, output feedback, full-duplex delayed CSIT, and delayed CSIT.

of full-duplex transmitter cooperation to yield DoF gains in multi-user networks.

Chapter 5

Conclusion

In this dissertation, we studied the impact of feedback and transmitter cooperation on communication performance over several wireless networks. All networks were assumed to be subject to i.i.d. fading and additive white Gaussian noise, and moreover, no instantaneous knowledge of CSI were assumed at the transmitter(s). The following summarizes our main contributions in this dissertation:

5.1 Summary of Main Contributions

In Chapter 2, we investigated the DoF of the 3-user MIMO broadcast channel assuming that the CSI is fed back to the transmitter after a finite delay (*delayed CSIT* assumption). We considered both the symmetric case with M antennas at the transmitter and N antennas at each receiver and the general non-symmetric case. For the symmetric case, we achieved DoFs that meet the upper bound for $M \leq 2N$ and $M \geq 3N$, and hence, characterize the channel sum-DoF with delayed CSIT. Our achievable DoF for $2N < M < 3N$ is close to the known upper bound on the sum-DoF of this channel and approaches the upper bound as M approaches either ends of this interval. For the non-symmetric case, we proposed transmission schemes that meet the known outer bound, and thus, characterize the channel DoF region with delayed CSIT for certain classes of antenna configurations.

CHAPTER 5: CONCLUSION

In Chapter 3, we studied the K -user SISO IC and $2 \times K$ SISO X channel with delayed CSIT. We proposed novel multiphase transmission schemes that achieve DoFs strictly increasing in K and approaching limiting values of $4/(6 \ln 2 - 1)$ and $1/\ln 2$ as $K \rightarrow \infty$, respectively, for the interference and X channels. To the best of our knowledge, our achievable DoFs for both channels are yet the best reported DoF results. Our transmission schemes employ new sequential interference cancellation/retransmission approaches that align the past interference at appropriate receivers. We also considered the K -user r -cyclic IC and showed that this channel has K/r DoF with no CSIT. Then, focusing on $r = 3$, we showed that the 3-cyclic IC can achieve strictly more than $K/3$ DoF with delayed CSIT.

In Chapter 4, we considered the K -user SISO IC and $M \times K$ SISO X channel without any *instantaneous* CSIT. We first enabled the transmitters to operate in *full-duplex* mode, i.e., transmit and receive simultaneously, and obtained achievable DoFs for both channels under delayed CSIT assumption. We demonstrated how the transmitters can exploit their partial knowledge of each others' messages, obtained via the full-duplex operation, to efficiently align the past interference. Our achievable DoFs in this part are greater than the best known achievable DoFs for the same channels with delayed CSIT (achieved in Chapter 3). This corroborates the potential of full-duplex transmitter cooperation to increase the channel DoF when the CSIT is delayed. We emphasize here that this type of cooperation cannot yield any DoF gain in the channels under consideration when there is either full CSI or no CSI at the transmitters (cf. [11, 56]).

We then considered the K -user SISO IC and $K \times K$ SISO X channel with *output feedback*, where each transmitter causally accesses the output of its paired receiver and each receiver obtains the whole CSI with a finite delay. Having no CSIT, we proposed transmission schemes wherein each transmitter using its partial knowledge of other transmitters' messages, obtained via the output feedback, cooperates with them in aligning the interference in a multiphase fashion. The level of cooperation attained through the output feedback turned out to be higher than that with full-duplex delayed CSIT, and thus, yielded higher DoFs for both channels for almost all values of K .

Finally, we considered the K -user SISO IC and $M \times K$ SISO X channel with *Shannon feedback*, where each transmitter accesses both the output feedback and delayed CSI. We

showed that the transmitters can enjoy a higher level of cooperation compared to our scheme with output feedback, and hence, greater DoFs were achieved for almost all values of K .

5.2 Future Research Directions

The works in this dissertation can be followed in different directions, some of which are highlighted as follows:

5.2.1 Upper Bounds

The main focus of the dissertation was on achievable DoFs for different multi-user channels under different feedback/transmitter cooperation models. However, without tight upper bounds, no optimality argument can be made for any of the considered channels, except for the broadcast channel. Indeed, the only available upper bounds on the DoF of a multi-user channel with delayed CSIT are for the K -user MISO broadcast channel in [34] (which was immediately applied to the MIMO case in [55]) and for the two-user MIMO IC in [57]. There exists no non-trivial upper bound on the DoF of the K -user IC ($K \geq 3$) or $M \times K$ X channel ($M, K \geq 2$) with delayed CSIT, full-duplex delayed CSIT, output feedback, or Shannon feedback. For the three-user MIMO broadcast channel studied in Chapter 2, there are still classes of antenna configurations for which there is a gap between our achievable DoF and the upper bound. In these cases, it is an open problem whether our achievable DoF or the upper bound or none of them is tight.

5.2.2 Finite SNR Regime: Capacity Characterization

Although the schemes proposed in this dissertation were designed to efficiently exploit the available DoF in the channels under consideration (i.e., the infinite SNR regime), they can be extended to finite SNR regime as well and their achievable rates can be analyzed. However, capacity characterization of multi-user channels under the considered

CHAPTER 5: CONCLUSION

feedback/cooperation models requires specific treatment of noise as well as interference, and opens an interesting research direction to follow. A very recent work on achievable rates of the K -user MISO broadcast channel with delayed CSIT in finite SNR regime can be found in [64].

5.2.3 Security Issues

Security is an important issue in all wireless systems. Characterization of secure DoF, achievable rates and capacity for several wireless networks has become very popular recently. There are few recent works on secure DoF under delayed CSIT assumption, cf. two-user MIMO broadcast channel with confidential messages in [61] and MISO wiretap channel in [62]. Investigation of information theoretical security aspects of the channels considered in this dissertation is another direction of research.

Appendices

Appendix A

Closed Form Expressions

A.1 Closed Form Expression for the Recursive Equation (3.58)

In this appendix, we derive a closed form solution to the recursive equation

$$\underline{\text{DoF}}_{K-i}^{\text{IC}}(K) = \frac{(K-i)(2i+1)}{(K-i)(i+1) + \frac{i}{K-i+1} + \frac{(K-i-1)i}{\underline{\text{DoF}}_{K-i+1}^{\text{IC}}(K)}}, \quad 1 \leq i \leq K-2, \quad (\text{A.1})$$

$$\underline{\text{DoF}}_K^{\text{IC}}(K) = 1. \quad (\text{A.2})$$

We start by rearranging (A.1) in the form of

$$1 - \frac{1}{\underline{\text{DoF}}_{K-i}^{\text{IC}}(K)} = \frac{i}{(K-i)(2i+1)} \left[(K-i-1) \left(1 - \frac{1}{\underline{\text{DoF}}_{K-i+1}^{\text{IC}}(K)} \right) + \frac{K-i}{K-i+1} \right], \quad (\text{A.3})$$

for $1 \leq i \leq K-2$, and defining $A_{K-i}(K) \triangleq 1 - \frac{1}{\underline{\text{DoF}}_{K-i}^{\text{IC}}(K)}$. Then, we have

$$A_{K-i}(K) = \frac{i}{(K-i)(2i+1)} \left[(K-i-1)A_{K-i+1}(K) + \frac{K-i}{K-i+1} \right], \quad 1 \leq i \leq K-2, \quad (\text{A.4})$$

$$A_K(K) = 0. \quad (\text{A.5})$$

APPENDIX A: CLOSED FORM EXPRESSIONS

Express $A_{K-i}(K)$ as

$$A_{K-i}(K) = \sum_{\ell=0}^i \frac{a_{K-\ell}^{[K-i]}}{K-\ell}, \quad (\text{A.6})$$

where $a_{K-\ell}^{[K-i]}$ is found using

$$a_{K-\ell}^{[K-i]} = [(K-\ell)A_{K-i}(K)] \Big|_{K=\ell}, \quad 0 \leq \ell \leq i. \quad (\text{A.7})$$

Substituting the expansion of (A.6) for $A_{K-i+1}(K)$ in (A.4), we get

$$A_{K-i}(K) = \frac{i}{(K-i)(2i+1)} \left[\sum_{\ell=0}^{i-1} \frac{(K-i-1)a_{K-\ell}^{[K-i+1]}}{K-\ell} + \frac{K-i}{K-i+1} \right]. \quad (\text{A.8})$$

Equations (A.7) and (A.8) lead to three recursive equations as follows:

$$a_{K-\ell}^{[K-i]} = \frac{(i-\ell+1)i}{(i-\ell)(2i+1)} a_{K-\ell}^{[K-i+1]}, \quad 0 \leq \ell \leq i-2, \quad (\text{A.9})$$

$$a_{K-i+1}^{[K-i]} = \frac{i}{2i+1} \left(2a_{K-i+1}^{[K-i+1]} + 1 \right), \quad (\text{A.10})$$

$$\begin{aligned} a_{K-i}^{[K-i]} &= -\frac{i}{2i+1} \sum_{\ell=0}^{i-1} \frac{a_{K-\ell}^{[K-i+1]}}{i-\ell} \\ &= -\frac{i}{2i+1} a_{K-i+1}^{[K-i+1]} - \sum_{\ell=0}^{i-2} \frac{a_{K-\ell}^{[K-i]}}{i-\ell+1}, \end{aligned} \quad (\text{A.11})$$

where (A.11) follows from (A.9). Applying (A.9) $i-\ell-1$ times, we will have

$$a_{K-\ell}^{[K-i]} = \frac{1}{2} a_{K-\ell}^{[K-\ell-1]} (i-\ell+1) \prod_{j=\ell+2}^i \frac{j}{2j+1}, \quad 0 \leq \ell \leq i-2. \quad (\text{A.12})$$

Substituting (A.12) in (A.11), we get

$$\begin{aligned} a_{K-i}^{[K-i]} &= -\frac{i}{2i+1} a_{K-i+1}^{[K-i+1]} - \frac{1}{2} \sum_{\ell=0}^{i-2} a_{K-\ell}^{[K-\ell-1]} \prod_{j=\ell+2}^i \frac{j}{2j+1} \\ &\stackrel{(a)}{=} -\frac{i}{2i+1} \left[-\frac{(i-1)a_{K-i+2}^{[K-i+2]}}{2(i-1)+1} - \frac{1}{2} \sum_{\ell=0}^{i-3} a_{K-\ell}^{[K-\ell-1]} \prod_{j=\ell+2}^{i-1} \frac{j}{2j+1} \right] - \frac{1}{2} \sum_{\ell=0}^{i-2} a_{K-\ell}^{[K-\ell-1]} \prod_{j=\ell+2}^i \frac{j}{2j+1} \\ &= \frac{i(i-1)}{(2i+1)[2(i-1)+1]} a_{K-i+2}^{[K-i+2]} - \frac{i}{2(2i+1)} a_{K-i+1}^{[K-i+1]} \end{aligned} \quad (\text{A.13})$$

APPENDIX A: CLOSED FORM EXPRESSIONS

$$\begin{aligned}
&\stackrel{(b)}{=} \frac{i(i-1)}{(2i+1)[2(i-1)+1]} a_{K-i+2}^{[K-i+2]} - \frac{i}{2(2i+1)} \times \frac{i-1}{2(i-1)+1} \left(2a_{K-i+2}^{[K-i+2]} + 1 \right) \\
&= -\frac{i(i-1)}{2(2i+1)[2(i-1)+1]} \\
&= -\frac{i(i-1)}{2(4i^2-1)}, \quad 0 \leq i \leq K-2,
\end{aligned} \tag{A.14}$$

where (a) results from reapplying (A.13) to $a_{K-i+1}^{[K-i+1]}$, and (b) follows from applying (A.10) to a_{K-i+2}^{K-i+1} .

Employing (A.14) for $a_{K-i+1}^{[K-i+1]}$ in (A.10), one can obtain

$$\begin{aligned}
a_{K-i+1}^{[K-i]} &= \frac{i}{2i+1} \left[1 - \frac{(i-1)(i-2)}{4(i-1)^2-1} \right] \\
&= \frac{i}{2i+1} \times \frac{3(i-1)^2 + (i-1) - 1}{4(i-1)^2-1}, \quad 0 \leq i \leq K-2.
\end{aligned} \tag{A.15}$$

It follows from substituting (A.15) in (A.12) that

$$a_{K-\ell}^{[K-i]} = \frac{(i-\ell+1)(3\ell^2+\ell-1)}{2(4\ell^2-1)} \prod_{j=\ell+1}^i \frac{j}{2j+1}, \quad 0 \leq \ell \leq i-2. \tag{A.16}$$

Finally, using (A.6) and (A.14) to (A.16), we have

$$A_{K-i}(K) = -\frac{i(i-1)}{2(4i^2-1)(K-i)} + \sum_{\ell=0}^{i-1} \frac{(i-\ell+1)(3\ell^2+\ell-1)}{2(K-\ell)(4\ell^2-1)} \prod_{j=\ell+1}^i \frac{j}{2j+1}, \quad 0 \leq i \leq K-2. \tag{A.17}$$

Since, by definition, $\underline{\text{DoF}}_{K-i}^{\text{IC}}(K) = \frac{1}{1-A_{K-i}(K)}$, we have the following closed form expression for $\underline{\text{DoF}}_{K-i}^{\text{IC}}(K)$, $0 \leq i \leq K-2$:

$$\underline{\text{DoF}}_{K-i}^{\text{IC}}(K) = \left[1 + \frac{i(i-1)}{2(4i^2-1)(K-i)} - \sum_{\ell=0}^{i-1} \frac{(i-\ell+1)(3\ell^2+\ell-1)}{2(K-\ell)(4\ell^2-1)} \prod_{j=\ell+1}^i \frac{j}{2j+1} \right]^{-1}. \tag{A.18}$$

A.2 Closed Form Expression for the Recursive Equation (3.88)

In this appendix, we derive the closed form solution to the recursive equation

$$\underline{\text{DoF}}_{K-i}^X(2, K) = \frac{(K-i+1)(2i+1)}{(K-i+1)(i+1) + \frac{(K-i)i}{\underline{\text{DoF}}_{K-i+1}^X(2, K)}}, \quad 1 \leq i \leq K-1, \quad (\text{A.19})$$

$$\underline{\text{DoF}}_K^X(2, K) = 1. \quad (\text{A.20})$$

Rearranging (A.19) in the form of

$$1 - \frac{1}{\underline{\text{DoF}}_{K-i}^X(2, K)} = \frac{i}{(K-i+1)(2i+1)} \left[(K-i) \left(1 - \frac{1}{\underline{\text{DoF}}_{K-i+1}^X(2, K)} \right) + 1 \right], \quad (\text{A.21})$$

for $1 \leq i \leq K-1$, and defining $B_{K-i}(K) \triangleq 1 - \frac{1}{\underline{\text{DoF}}_{K-i}^X(2, K)}$, one can write

$$B_{K-i}(K) = \frac{i}{(K-i+1)(2i+1)} [(K-i)B_{K-i+1}(K) + 1], \quad 1 \leq i \leq K-1, \quad (\text{A.22})$$

$$B_K(K) = 0. \quad (\text{A.23})$$

Express $B_{K-i}(K)$ as

$$B_{K-i}(K) = \sum_{\ell=0}^{i-1} \frac{b_{K-\ell}^{[K-i]}}{K-\ell}, \quad (\text{A.24})$$

where $b_{K-\ell}^{[K-i]}$ is found using

$$b_{K-\ell}^{[K-i]} = [(K-\ell)B_{K-i}(K)] \Big|_{K=\ell}, \quad 0 \leq \ell \leq i-1. \quad (\text{A.25})$$

Substituting the expansion of (A.24) for $B_{K-i+1}(K)$ in (A.22), we get

$$B_{K-i}(K) = \frac{i}{(K-i+1)(2i+1)} \left[\sum_{\ell=0}^{i-2} \frac{(K-i)b_{K-\ell}^{[K-i+1]}}{K-\ell} + 1 \right]. \quad (\text{A.26})$$

Equations (A.25) and (A.26) result in two recursive equations as follows:

$$b_{K-\ell}^{[K-i]} = \frac{(i-\ell)i}{(i-\ell-1)(2i+1)} b_{K-\ell}^{[K-i+1]}, \quad 0 \leq \ell \leq i-2, \quad (\text{A.27})$$

APPENDIX A: CLOSED FORM EXPRESSIONS

$$\begin{aligned}
b_{K-i+1}^{[K-i]} &= \frac{i}{2i+1} \left[1 - \sum_{\ell=0}^{i-2} \frac{b_{K-\ell}^{[K-i+1]}}{i-\ell-1} \right] \\
&= \frac{i}{2i+1} - \sum_{\ell=0}^{i-2} \frac{b_{K-\ell}^{[K-i]}}{i-\ell},
\end{aligned} \tag{A.28}$$

where (A.28) follows from (A.27). Applying (A.27) $i - \ell - 1$ times, we will have

$$b_{K-\ell}^{[K-i]} = b_{K-\ell}^{[K-\ell-1]}(i-\ell) \prod_{j=\ell+2}^i \frac{j}{2j+1}, \quad 0 \leq \ell \leq i-2. \tag{A.29}$$

Substituting (A.29) in (A.28), it follows that

$$\begin{aligned}
b_{K-i+1}^{[K-i]} &= \frac{i}{2i+1} - \sum_{\ell=0}^{i-2} b_{K-\ell}^{[K-\ell-1]} \prod_{j=\ell+2}^i \frac{j}{2j+1} \\
&= \frac{i}{2i+1} - \frac{i}{2i+1} b_{K-i+2}^{[K-i+1]} - \sum_{\ell=0}^{i-3} b_{K-\ell}^{[K-\ell-1]} \prod_{j=\ell+2}^i \frac{j}{2j+1} \\
&= \frac{i}{2i+1} - \frac{i}{2i+1} b_{K-i+2}^{[K-i+1]} - \frac{i}{2i+1} \sum_{\ell=0}^{i-3} b_{K-\ell}^{[K-\ell-1]} \prod_{j=\ell+2}^{i-1} \frac{j}{2j+1} \\
&= \frac{i}{2i+1} - \frac{i}{2i+1} \left[b_{K-i+2}^{[K-i+1]} + \sum_{\ell=0}^{i-3} b_{K-\ell}^{[K-\ell-1]} \prod_{j=\ell+2}^{i-1} \frac{j}{2j+1} \right] \\
&\stackrel{(a)}{=} \frac{i}{2i+1} - \frac{i}{2i+1} \times \frac{i-1}{2(i-1)+1} \\
&= \frac{i^2}{4i^2-1}, \quad 0 \leq i \leq K-1,
\end{aligned} \tag{A.31}$$

where (a) simply follows from an application of (A.30) for $b_{K-i+2}^{[K-i+1]}$. Substituting (A.31) for $b_{K-\ell}^{[K-\ell-1]}$ in (A.29), we obtain

$$b_{K-\ell}^{[K-i]} = \frac{(i-\ell)(\ell+1)}{2(\ell+1)-1} \prod_{j=\ell+1}^i \frac{j}{2j+1}, \quad 0 \leq \ell \leq i-2. \tag{A.32}$$

Combining (A.24), (A.31) and (A.32), we can write

$$B_{K-i}(K) = \sum_{\ell=0}^{i-1} \frac{(i-\ell)(\ell+1)}{(K-\ell)[2(\ell+1)-1]} \prod_{j=\ell+1}^i \frac{j}{2j+1}, \quad 0 \leq i \leq K-1. \tag{A.33}$$

APPENDIX A: CLOSED FORM EXPRESSIONS

which together with $\underline{\text{DoF}}_{K-i}^X(2, K) = \frac{1}{1-B_{K-i}(K)}$, yields

$$\underline{\text{DoF}}_{K-i}^X(2, K) = \left[1 - \sum_{\ell=0}^{i-1} \frac{(i-\ell)(\ell+1)}{(K-\ell)(2\ell+1)} \prod_{j=\ell+1}^i \frac{j}{2j+1} \right]^{-1}, \quad 0 \leq i \leq K-1. \quad (\text{A.34})$$

A.3 Closed Form Expression for the Recursive Equations (4.44) and (4.56)

Consider the following recursive equation:

$$\underline{\text{DoF}}_m(K) = \frac{m+1}{m} \times \frac{Q_m(K)}{1 + \frac{Q_m(K)-1}{\underline{\text{DoF}}_{m+1}(K)}}, \quad 2 \leq m \leq K-2, \quad (\text{A.35})$$

with $Q_m(K) = \min\{K-m, m\}$ and the initial condition $\underline{\text{DoF}}_{K-1}(K) = K/(K-1)$. We treat two different cases separately:

(i) $\lceil K/2 \rceil \leq m \leq K-1$: In this case, we have $Q_m(K) = K-m$, and hence,

$$\frac{K-m}{m\underline{\text{DoF}}_m(K)} = \frac{1}{m+1} + \frac{K-m-1}{(m+1)\underline{\text{DoF}}_{m+1}(K)}. \quad (\text{A.36})$$

Then, defining $\gamma_m(K) \triangleq \frac{K-m}{m\underline{\text{DoF}}_m(K)}$, one can write $\gamma_m(K) = \frac{1}{m+1} + \gamma_{m+1}(K)$, which implies that $\gamma_m(K) = \sum_{\ell=m+1}^K \frac{1}{\ell}$, or equivalently,

$$\underline{\text{DoF}}_m(K) = \left(\frac{m}{K-m} \sum_{\ell=m+1}^K \frac{1}{\ell} \right)^{-1}, \quad \lceil K/2 \rceil \leq m \leq K-1. \quad (\text{A.37})$$

(ii) $2 \leq m < \lceil K/2 \rceil$: In this case, we have

$$\frac{1}{\underline{\text{DoF}}_m(K)} = \frac{1}{m+1} + \left(\frac{m-1}{m+1} \right) \frac{1}{\underline{\text{DoF}}_{m+1}(K)}, \quad (\text{A.38})$$

which can be rewritten as

$$\frac{2}{\underline{\text{DoF}}_m(K)} - 1 = \frac{m-1}{m+1} \left(\frac{2}{\underline{\text{DoF}}_{m+1}(K)} - 1 \right). \quad (\text{A.39})$$

APPENDIX A: CLOSED FORM EXPRESSIONS

It immediately follows that

$$\begin{aligned} \frac{2}{\underline{\text{DoF}}_m(K)} - 1 &= \frac{m(m-1)}{\lceil \frac{K}{2} \rceil (\lceil \frac{K}{2} \rceil - 1)} \left(\frac{2}{\underline{\text{DoF}}_{\lceil \frac{K}{2} \rceil}(K)} - 1 \right) \\ &\stackrel{(a)}{=} \frac{m(m-1)}{\lceil \frac{K}{2} \rceil (\lceil \frac{K}{2} \rceil - 1)} \left(\frac{2^{\lceil \frac{K}{2} \rceil} \sum_{\ell=\lceil \frac{K}{2} \rceil+1}^K \frac{1}{\ell}}{\lfloor \frac{K}{2} \rfloor} - 1 \right), \end{aligned} \quad 2 \leq m < \lceil K/2 \rceil, \quad (\text{A.40})$$

where (a) uses (A.37) with $m = \lceil \frac{K}{2} \rceil$, and the fact that $K - \lceil \frac{K}{2} \rceil = \lfloor \frac{K}{2} \rfloor$.

It finally follows from (A.37) and (A.40) that

$$\underline{\text{DoF}}_m(K) = \begin{cases} \left(\frac{1}{2} - \frac{m(m-1)}{2\lceil \frac{K}{2} \rceil (\lceil \frac{K}{2} \rceil - 1)} + \frac{m(m-1)}{\lfloor \frac{K}{2} \rfloor (\lceil \frac{K}{2} \rceil - 1)} \sum_{\ell=\lceil \frac{K}{2} \rceil+1}^K \frac{1}{\ell} \right)^{-1}, & 2 \leq m \leq \lceil \frac{K}{2} \rceil \\ \left(\frac{m}{K-m} \sum_{\ell=m+1}^K \frac{1}{\ell} \right)^{-1}, & \lceil \frac{K}{2} \rceil < m \leq K-1 \end{cases}. \quad (\text{A.41})$$

A.4 Closed Form Expression for the Recursive Equation (4.53)

Consider the recursive equation

$$\underline{\text{DoF}}_m(M, K) = \frac{(m+1)(Q_m(M, K) + 1)}{m+1 + \frac{m \times Q_m(M, K)}{\underline{\text{DoF}}_{m+1}(M, K)}}, \quad 1 \leq m \leq K-1, \quad (\text{A.42})$$

with $Q_m(M, K) = \min\{M-1, K-m, m\}$ and initial condition $\underline{\text{DoF}}_K(M, K) = 1$. The following distinct cases can be differentiated:

(i) $M-1 \geq \lceil K/2 \rceil$: In this case, $Q_m(M, K) = Q_m(K) = \min\{K-m, m\}$, and hence,

$$\frac{Q_m(K) + 1}{m \underline{\text{DoF}}_m(M, K)} = \frac{1}{m} + \frac{Q_m(K)}{(m+1) \underline{\text{DoF}}_{m+1}(M, K)}. \quad (\text{A.43})$$

Now, if $\lceil K/2 \rceil \leq m \leq K$, then similar to Appendix A.3, one can show that

$$\underline{\text{DoF}}_m(K) = \left(\frac{m}{K-m+1} \sum_{\ell=m}^K \frac{1}{\ell} \right)^{-1}, \quad \lceil K/2 \rceil \leq m \leq K. \quad (\text{A.44})$$

APPENDIX A: CLOSED FORM EXPRESSIONS

Otherwise, the recursive (A.43) can be rewritten as

$$\begin{aligned}
\frac{1}{m^2 \underline{\text{DoF}}_m(M, K)} &= \frac{1}{m^2(m+1)} + \frac{1}{(m+1)^2 \underline{\text{DoF}}_{m+1}(M, K)} \\
&= \sum_{\ell=m}^{\lceil \frac{K}{2} \rceil - 1} \frac{1}{\ell^2(\ell+1)} + \frac{1}{\lceil \frac{K}{2} \rceil^2 \underline{\text{DoF}}_{\lceil \frac{K}{2} \rceil}(M, K)} \\
&\stackrel{(a)}{=} \frac{1}{\lceil \frac{K}{2} \rceil} - \frac{1}{m} + \sum_{\ell=m}^{\lceil \frac{K}{2} \rceil - 1} \frac{1}{\ell^2} + \frac{1}{\lceil \frac{K}{2} \rceil (\lfloor \frac{K}{2} \rfloor + 1)} \sum_{\ell=\lceil \frac{K}{2} \rceil}^K \frac{1}{\ell}, \quad 1 \leq m < \lceil K/2 \rceil,
\end{aligned} \tag{A.45}$$

where (a) uses (A.44) with $m = \lceil \frac{K}{2} \rceil$, and the fact that $K - \lceil \frac{K}{2} \rceil = \lfloor \frac{K}{2} \rfloor$.

Equations (A.44) and (A.45) yield

$$\underline{\text{DoF}}_m(M, K) = \begin{cases} \left(\frac{m^2}{\lceil \frac{K}{2} \rceil} - m + m^2 \sum_{\ell=m}^{\lceil \frac{K}{2} \rceil - 1} \frac{1}{\ell^2} + \frac{m^2}{\lceil \frac{K}{2} \rceil (\lfloor \frac{K}{2} \rfloor + 1)} \sum_{\ell=\lceil \frac{K}{2} \rceil}^K \frac{1}{\ell} \right)^{-1}, & 1 \leq m < \lceil \frac{K}{2} \rceil \\ \left(\frac{m}{K-m+1} \sum_{\ell=m}^K \frac{1}{\ell} \right)^{-1}, & \lceil \frac{K}{2} \rceil \leq m \leq K \end{cases}. \tag{A.46}$$

(ii) $M-1 < \lceil K/2 \rceil$: In this case, if $K-M+1 \leq m \leq K$, then the same expression as (A.44) holds for $\underline{\text{DoF}}_m(K)$. Otherwise, if $M-1 \leq m < K-M+1$, then $Q_m(M, K) = M-1$, and we have

$$\begin{aligned}
\frac{1}{m \underline{\text{DoF}}_m(M, K)} &= \frac{1}{mM} + \left(\frac{M-1}{M} \right) \frac{1}{(m+1) \underline{\text{DoF}}_{m+1}(M, K)} \\
&= \frac{1}{M} \sum_{\ell=m}^{K-M} \left(\frac{M-1}{M} \right)^{\ell-m} \frac{1}{\ell} + \frac{\left(\frac{M-1}{M} \right)^{K-M-m+1}}{(K-M+1) \underline{\text{DoF}}_{K-M+1}(M, K)} \\
&\stackrel{(a)}{=} \frac{1}{M} \sum_{\ell_1=m}^{K-M} \left(\frac{M-1}{M} \right)^{\ell_1-m} \frac{1}{\ell_1} + \frac{1}{M} \left(\frac{M-1}{M} \right)^{K-M-m+1} \sum_{\ell_2=K-M+1}^K \frac{1}{\ell_2},
\end{aligned} \tag{A.47}$$

where (a) follows from (A.44) with $m = K-M+1$. Therefore,

$$\underline{\text{DoF}}_m(M, K) = \left(\frac{m}{M} \sum_{\ell=m}^K \frac{1}{\ell} \left(\frac{M-1}{M} \right)^{\min(\ell, K-M+1)-m} \right)^{-1}, \quad M-1 \leq m < K-M+1. \tag{A.48}$$

APPENDIX A: CLOSED FORM EXPRESSIONS

Finally, if $1 \leq m < M - 1$, then

$$\begin{aligned}
\frac{1}{m^2 \underline{\text{DoF}}_m(M, K)} &= \frac{1}{m^2(m+1)} + \frac{1}{(m+1)^2 \underline{\text{DoF}}_{m+1}(M, K)} \\
&= \frac{1}{M-1} - \frac{1}{m} + \sum_{\ell=m}^{M-2} \frac{1}{\ell^2} + \frac{1}{(M-1)^2 \underline{\text{DoF}}_{M-1}(M, K)} \\
&\stackrel{(a)}{=} \frac{1}{M-1} - \frac{1}{m} + \sum_{\ell_1=m}^{M-2} \frac{1}{\ell_1^2} + \frac{1}{M^2} \sum_{\ell_2=M-1}^K \frac{1}{\ell_2} \left(\frac{M-1}{M} \right)^{\min(\ell_2, K-M+1)-M},
\end{aligned} \tag{A.49}$$

where (a) uses (A.48) with $m = M - 1$. Thus, for $1 \leq m < M - 1$,

$$\underline{\text{DoF}}_m(M, K) = \frac{1}{\frac{m^2}{M-1} - m + m^2 \sum_{\ell_1=m}^{M-2} \frac{1}{\ell_1^2} + \left(\frac{m}{M}\right)^2 \sum_{\ell_2=M-1}^K \frac{1}{\ell_2} \left(\frac{M-1}{M}\right)^{\min(\ell_2, K-M+1)-M}}. \tag{A.50}$$

A.5 Closed Form Expression for the Recursive Equation (4.66)

Consider the recursive equation

$$\underline{\text{DoF}}_m(K) = \frac{(m+1)Q_m(K+1)}{m+1 + \frac{m \times (Q_m(K+1)-1)}{\underline{\text{DoF}}_{m+1}(K)}}, \quad 2 \leq m \leq K-1, \tag{A.51}$$

with initial condition $\underline{\text{DoF}}_K(K) = 1$. For $\lfloor \frac{K}{2} \rfloor < m \leq K$, it is easily shown that $\underline{\text{DoF}}_m(K)$ is given by (A.44). For $2 \leq m \leq \lfloor \frac{K}{2} \rfloor$, we have

$$\begin{aligned}
\frac{1}{\underline{\text{DoF}}_m(K)} &= \frac{1}{m} + \left(\frac{m-1}{m+1} \right) \frac{1}{\underline{\text{DoF}}_{m+1}(K)} \\
&= \frac{1}{m} + m(m-1) \sum_{\ell=m}^{\lfloor \frac{K}{2} \rfloor - 1} \frac{1}{\ell(\ell+1)^2} + \left(\frac{m(m-1)}{\lfloor \frac{K}{2} \rfloor (\lfloor \frac{K}{2} \rfloor + 1)} \right) \frac{1}{\underline{\text{DoF}}_{\lfloor \frac{K}{2} \rfloor + 1}(K)} \\
&\stackrel{(a)}{=} \frac{1}{m} + m-1 - \frac{m(m-1)}{\lfloor \frac{K}{2} \rfloor} - m(m-1) \sum_{\ell_1=m+1}^{\lfloor \frac{K}{2} \rfloor} \frac{1}{\ell_1^2} + \frac{m(m-1)}{\lfloor \frac{K}{2} \rfloor \lceil \frac{K}{2} \rceil} \sum_{\ell_2=\lfloor \frac{K}{2} \rfloor + 1}^K \frac{1}{\ell_2},
\end{aligned} \tag{A.52}$$

APPENDIX A: CLOSED FORM EXPRESSIONS

where (a) uses (A.44) with $m = \lfloor \frac{K}{2} \rfloor + 1$, and the fact that $K - \lfloor \frac{K}{2} \rfloor = \lceil \frac{K}{2} \rceil$. Therefore, for $2 \leq m \leq \lfloor K/2 \rfloor$,

$$\underline{\text{DoF}}_m(K) = \left(\frac{1}{m} + m(m-1) \left[\frac{1}{m} - \frac{1}{\lfloor \frac{K}{2} \rfloor} - \sum_{\ell_1=m+1}^{\lfloor \frac{K}{2} \rfloor} \frac{1}{\ell_1^2} + \frac{1}{\lfloor \frac{K}{2} \rfloor \lceil \frac{K}{2} \rceil} \sum_{\ell_2=\lfloor \frac{K}{2} \rfloor+1}^K \frac{1}{\ell_2} \right] \right)^{-1}. \quad (\text{A.53})$$

Appendix B

Proofs of Linear Independence

B.1 Proof of Linear Independence in Phase 1 for the K -user IC with Delayed CSIT

In this appendix, we show that after phase 1 of the proposed transmission scheme for the K -user SISO IC with delayed CSIT, the $(K-1)^2$ linear equations obtained by each receiver in terms of its data symbols are linearly independent almost surely (see Section 3.3.2, (3.39) and (3.40)). To this end, consider the aforementioned equations at RX_j , $1 \leq j \leq K$:

$$(\mathbf{u}^{[j]})^T \mathbf{Q}_{jj}^T \boldsymbol{\omega}_{ji_1}, \quad i_1 \in \mathcal{S}_K \setminus \{j\}, \quad (\text{B.1})$$

$$(\mathbf{u}^{[j]})^T \mathbf{Q}_{i_2j}^T \boldsymbol{\omega}_{i_2i_3}, \quad i_2, i_3 \in \mathcal{S}_K \setminus \{j\}, i_2 \neq i_3, \quad (\text{B.2})$$

which are equivalent to the system of linear equations $(\mathbf{u}^{[j]})^T \mathbf{P}^{[j]}$, where $\mathbf{P}^{[j]}$ is a $(K-1)^2 \times (K-1)^2$ matrix defined as

$$\mathbf{P}^{[j]} \triangleq \left[\left\{ \mathbf{Q}_{jj}^T \boldsymbol{\omega}_{ji_1} \right\}_{i_1 \in \mathcal{S}_K \setminus \{j\}}, \left\{ \mathbf{Q}_{i_2j}^T \boldsymbol{\omega}_{i_2i_3} \right\}_{i_2, i_3 \in \mathcal{S}_K \setminus \{j\}, i_2 \neq i_3} \right] \quad (\text{B.3})$$

$$= (\mathbf{C}^{[j]})^T \left[\left\{ \mathbf{D}_{jj} \boldsymbol{\omega}_{ji_1} \right\}_{i_1 \in \mathcal{S}_K \setminus \{j\}}, \left\{ \mathbf{D}_{i_2j} \boldsymbol{\omega}_{i_2i_3} \right\}_{i_2, i_3 \in \mathcal{S}_K \setminus \{j\}, i_2 \neq i_3} \right]. \quad (\text{B.4})$$

Let $\tilde{\mathbf{h}}_{ij}$ denote the vector of length $(K-1)^2 + 1$ containing the main diagonal of \mathbf{D}_{ij} and define $\mathbf{v}_\ell \triangleq \underbrace{[1, 1, \dots, 1]^T}_\ell$. Then, one can write

$$\mathbf{P}^{[j]} = (\mathbf{C}^{[j]})^T \left(\tilde{\mathbf{H}}^{[j]} \circ \boldsymbol{\Omega}^{[j]} \right), \quad (\text{B.5})$$

APPENDIX B: PROOFS OF LINEAR INDEPENDENCE

where

$$\tilde{\mathbf{H}}^{[j]} \triangleq \left[\tilde{\mathbf{h}}_{jj} \mathbf{v}_{K-1}^T, \left\{ \tilde{\mathbf{h}}_{ij} \mathbf{v}_{K-2}^T \right\}_{i \in \mathcal{S}_K \setminus \{j\}} \right], \quad (\text{B.6})$$

$$\mathbf{\Omega}^{[j]} \triangleq \left[\left\{ \boldsymbol{\omega}_{j i_1} \right\}_{i_1 \in \mathcal{S}_K \setminus \{j\}}, \left\{ \boldsymbol{\omega}_{i_2 i_3} \right\}_{i_2, i_3 \in \mathcal{S}_K \setminus \{j\}, i_2 \neq i_3} \right] = \left[\boldsymbol{\omega}_{j_1 i_1} \right]_{i_1 \in \mathcal{S}_K \setminus \{j\}, j_1 \in \mathcal{S}_K \setminus \{i_1\}}, \quad (\text{B.7})$$

and “ \circ ” denotes the *element-wise product* operator. Recall that

$$\mathbf{Q}_{j_1 i_1}^T \boldsymbol{\omega}_{j_1 i_1} = (\mathbf{C}^{[i_1]})^T \mathbf{D}_{j_1 i_1} \boldsymbol{\omega}_{j_1 i_1} = \mathbf{0}_{(K-1)^2 \times 1}. \quad (\text{B.8})$$

Hence, the vector $\mathbf{D}_{j_1 i_1} \boldsymbol{\omega}_{j_1 i_1}$ lies in the left null space of $\mathbf{C}^{[i_1]}$. However, $\mathbf{C}^{[i_1]}$ is a random $[(K-1)^2 + 1] \times (K-1)^2$ matrix, and thus, it is full rank almost surely and its left null space is one dimensional, denoted by the nonzero unit vector $\mathbf{n}^{[i_1]}$. It immediately follows that, for every $j_1 \in \mathcal{S}_K \setminus \{i_1\}$, there exists a nonzero scalar $a_{j_1 i_1}$ such that $\mathbf{D}_{j_1 i_1} \boldsymbol{\omega}_{j_1 i_1} = a_{j_1 i_1} \mathbf{n}^{[i_1]}$, or equivalently, $\boldsymbol{\omega}_{j_1 i_1} = a_{j_1 i_1} \mathbf{D}_{j_1 i_1}^{-1} \mathbf{n}^{[i_1]}$. Note that $\mathbf{D}_{j_1 i_1}$ is full rank, and so, invertible almost surely. Therefore, $\mathbf{\Omega}^{[j]}$ can be rewritten as follows

$$\mathbf{\Omega}^{[j]} = \left[a_{j_1 i_1} \mathbf{D}_{j_1 i_1}^{-1} \mathbf{n}^{[i_1]} \right]_{i_1 \in \mathcal{S}_K \setminus \{j\}, j_1 \in \mathcal{S}_K \setminus \{i_1\}}. \quad (\text{B.9})$$

Since $a_{j_1 i_1}$'s are nonzero and each of them scales a whole column of $\tilde{\mathbf{H}}^{[j]} \circ \mathbf{\Omega}^{[j]}$, they do not affect the rank. Hence,

$$\text{rank}(\tilde{\mathbf{H}}^{[j]} \circ \mathbf{\Omega}^{[j]}) = \text{rank}(\tilde{\mathbf{H}}^{[j]} \circ \left[\mathbf{D}_{j_1 i_1}^{-1} \mathbf{n}^{[i_1]} \right]_{i_1 \in \mathcal{S}_K \setminus \{j\}, j_1 \in \mathcal{S}_K \setminus \{i_1\}}). \quad (\text{B.10})$$

One also can write

$$\begin{aligned} \tilde{\mathbf{H}}^{[j]} \circ \left[\mathbf{D}_{j_1 i_1}^{-1} \mathbf{n}^{[i_1]} \right]_{i_1 \in \mathcal{S}_K \setminus \{j\}, j_1 \in \mathcal{S}_K \setminus \{i_1\}} &= \tilde{\mathbf{H}}^{[j]} \circ \mathbf{N}^{[j]} \circ (\hat{\mathbf{H}}^{[j]})^{\circ(-1)} \\ &= \boldsymbol{\Phi}^{[j]} \circ (\hat{\mathbf{H}}^{[j]})^{\circ(-1)}, \end{aligned} \quad (\text{B.11})$$

where

$$\hat{\mathbf{H}}^{[j]} \triangleq \left[\tilde{\mathbf{h}}_{j_1 i_1} \right]_{i_1 \in \mathcal{S}_K \setminus \{j\}, j_1 \in \mathcal{S}_K \setminus \{i_1\}} \quad (\text{B.12})$$

$$\mathbf{N}^{[j]} \triangleq \left[\mathbf{n}^{[i_1]} \mathbf{v}_{K-1}^T \right]_{i_1 \in \mathcal{S}_K \setminus \{j\}} \quad (\text{B.13})$$

$$\boldsymbol{\Phi}^{[j]} \triangleq \tilde{\mathbf{H}}^{[j]} \circ \mathbf{N}^{[j]}, \quad (\text{B.14})$$

APPENDIX B: PROOFS OF LINEAR INDEPENDENCE

and $(\hat{\mathbf{H}}^{[j]})^{\circ(-1)}$ denotes the element-wise inverse of $\hat{\mathbf{H}}^{[j]}$. We note that $\hat{\mathbf{H}}^{[j]}$ and $\mathbf{N}^{[j]}$ are independent of each other, since $\mathbf{N}^{[j]}$ is a function of $\{\mathbf{C}^{[i_1]}\}_{i_1 \in \mathcal{S}_K \setminus \{j\}}$ which are independent of $\hat{\mathbf{H}}^{[j]}$. Also, $\tilde{\mathbf{H}}^{[j]}$ and $\hat{\mathbf{H}}^{[j]}$ are independent of each other, since the channel coefficients are i.i.d. across the transmitters and receivers. Hence, $\Phi^{[j]}$ is independent of $\hat{\mathbf{H}}^{[j]}$.

On the other hand, it can be easily verified that the elements of $\hat{\mathbf{H}}^{[j]}$, and thereby $(\hat{\mathbf{H}}^{[j]})^{\circ(-1)}$, are i.i.d.. Also, it is easy to show that all elements of $\Phi^{[j]}$ are nonzero almost surely. Therefore, for any given $\Phi^{[j]}$, the elements of $\Phi^{[j]} \circ (\hat{\mathbf{H}}^{[j]})^{\circ(-1)}$ are also independent of each other, since $\Phi^{[j]}$ is independent of $(\hat{\mathbf{H}}^{[j]})^{\circ(-1)}$. This implies that, for any given $\Phi^{[j]}$, $\Phi^{[j]} \circ (\hat{\mathbf{H}}^{[j]})^{\circ(-1)}$ is full rank almost surely. This means that $\Phi^{[j]} \circ (\hat{\mathbf{H}}^{[j]})^{\circ(-1)}$ is full rank almost surely.

Finally, we note that $\mathbf{C}^{[j]}$ is independent of $\tilde{\mathbf{H}}^{[j]}$, $\mathbf{N}^{[j]}$, and $\hat{\mathbf{H}}^{[j]}$, and thereby, of $\tilde{\mathbf{H}}^{[j]} \circ \Omega^{[j]}$. Therefore, regarding (B.5), (B.10) and (B.11) and applying Lemma 1, one can conclude that $\mathbf{P}^{[j]}$ is full rank almost surely.

Lemma 1. *Let $\mathbf{A}_{m \times n}$ and $\mathbf{B}_{n \times m}$ be two independent (not necessarily i.i.d.) random matrices with continuous probability distributions and let $m \leq n$. If \mathbf{A} and \mathbf{B} are full rank almost surely, then \mathbf{AB} is full rank almost surely.*

Proof. If $m = n$, then the lemma is obviously true. Assume $m < n$. Let \mathbf{a}_i , $1 \leq i \leq n$, and \mathbf{b}_j , $1 \leq j \leq m$, be the i th and j th column of \mathbf{A} and \mathbf{B} , respectively. Then, the j th column of \mathbf{AB} can be written as $\sum_{i=1}^n b_{ji} \mathbf{a}_i$. Now, assume a linear combination of the columns of \mathbf{AB} are equal to zero, namely

$$\sum_{j=1}^m \gamma_j \sum_{i=1}^n b_{ji} \mathbf{a}_i = \mathbf{0}_{m \times 1}. \quad (\text{B.15})$$

Therefore, exchanging the order of the summations, we have $\sum_{i=1}^n \left(\sum_{j=1}^m \gamma_j b_{ji} \right) \mathbf{a}_i = \mathbf{0}_{m \times 1}$. This can be written in matrix form as follows

$$\mathbf{A} \left(\sum_{j=1}^m \gamma_j \mathbf{b}_j \right) = \mathbf{0}_{m \times 1}. \quad (\text{B.16})$$

Thus, the vector $\sum_{j=1}^m \gamma_j \mathbf{b}_j$ either is equal to zero or lies in the null space of \mathbf{A} . In the former case, we get $\gamma_j = 0$, $1 \leq j \leq m$, since \mathbf{B} is full rank almost surely. In the

APPENDIX B: PROOFS OF LINEAR INDEPENDENCE

latter case, since \mathbf{A} is full rank almost surely, its null space is $n - m$ dimensional. Let $\mathbf{N}_{n \times (n-m)} \triangleq [\mathbf{n}_1, \mathbf{n}_2, \dots, \mathbf{n}_{n-m}]$ denote the basis of the null space of \mathbf{A} . Then, there should exist ξ_ℓ , $1 \leq \ell \leq n - m$, such that

$$\sum_{j=1}^m \gamma_j \mathbf{b}_j = \sum_{\ell=1}^{n-m} \xi_\ell \mathbf{n}_\ell. \quad (\text{B.17})$$

Note that \mathbf{N} is independent of \mathbf{B} , since \mathbf{A} and \mathbf{B} are independent of each other. Consider the square matrix $[\mathbf{B}|\mathbf{N}]_{n \times n}$. Since \mathbf{B} and \mathbf{N} are full rank almost surely (with continuous distributions) and independent of each other, one can easily show that $[\mathbf{B}|\mathbf{N}]$ is full rank almost surely. This together with (B.17) yields $\gamma_j = 0$, $1 \leq j \leq m$, and $\xi_\ell = 0$, $1 \leq \ell \leq n - m$. \square

B.2 Proof of Linear Independence in Phase m -I for the K -user IC and Phase m for the $2 \times K$ X Channel with Delayed CSIT

Consider the following system of linear equations:

$$\mathbf{Q}_{j i_1} \mathbf{u}^{[i_1 | \mathcal{S}_m]} + \mathbf{Q}_{j i_2} \mathbf{u}^{[i_2 | \mathcal{S}_m]} \quad (\text{B.18})$$

$$(\mathbf{u}^{[i_1 | \mathcal{S}_m]})^T \mathbf{Q}_{j' i_1}^T \boldsymbol{\omega}_{j' i_2}, \quad j' \in \mathcal{S}_K \setminus \mathcal{S}_m. \quad (\text{B.19})$$

which are equivalent to the system of linear equation $(\mathbf{u}^{[\mathcal{S}_m]})^T \mathbf{G}^{[j]}$, where $\mathbf{G}^{[j]}$ and $\mathbf{u}^{[\mathcal{S}_m]}$ are defined as

$$\mathbf{G}^{[j]} \triangleq \left[\begin{array}{c|c} (\mathbf{Q}_{j i_1})^T & \{\mathbf{Q}_{j' i_1}^T \boldsymbol{\omega}_{j' i_2}\}_{j' \in \mathcal{S}_K \setminus \mathcal{S}_m} \\ \hline (\mathbf{Q}_{j i_2})^T & \mathbf{O} \end{array} \right], \quad (\text{B.20})$$

$$\mathbf{u}^{[\mathcal{S}_m]} \triangleq [(\mathbf{u}^{[i_1 | \mathcal{S}_m]})^T, (\mathbf{u}^{[i_2 | \mathcal{S}_m]})^T]^T. \quad (\text{B.21})$$

Note first that, by definition, $\mathbf{Q}_{j i_1} = \mathbf{D}_{j i_1} \mathbf{C}^{[i_1 | \mathcal{S}_m]}$ and $\mathbf{Q}_{j i_2} = \mathbf{D}_{j i_2} \mathbf{C}^{[i_2 | \mathcal{S}_m]}$. These matrix multiplications are nothing but scaling the columns of $\mathbf{C}^{[i_1 | \mathcal{S}_m]}$ and $\mathbf{C}^{[i_2 | \mathcal{S}_m]}$ by the diagonal elements of $\mathbf{D}_{j i_1}$ and $\mathbf{D}_{j i_2}$, respectively. Since the diagonal elements of $\mathbf{D}_{j i_1}$ and $\mathbf{D}_{j i_2}$ are

APPENDIX B: PROOFS OF LINEAR INDEPENDENCE

nonzero almost surely and since scaling the columns of a matrix by nonzero factors does not affect its rank, one can write

$$\text{rank}(\mathbf{Q}_{j^{i_1}}) = \text{rank}(\mathbf{C}^{[i_1|\mathcal{S}_m]}) = K - m + 1, \quad (\text{B.22})$$

$$\text{rank}(\mathbf{Q}_{j^{i_2}}) = \text{rank}(\mathbf{C}^{[i_2|\mathcal{S}_m]}) = K - m. \quad (\text{B.23})$$

Also, if a linear combination of some columns is added to a (nonzero) scaled version of a column in a matrix then its rank does not change. Therefore, if we replace the $K - m + 1$ 'th column of $\mathbf{G}^{[j]}$ with a linear combination of its first $K - m + 1$ columns, its rank will not change. If we choose the coefficients of such a linear combination to be the elements of $\boldsymbol{\omega}_{j^{i_2}}$ (which are all nonzero almost surely), then since by definition, $(\mathbf{Q}_{j^{i_2}})^T \boldsymbol{\omega}_{j^{i_2}} = \mathbf{0}_{(K-m) \times 1}$, we get

$$\text{rank}(\mathbf{G}^{[j]}) = \text{rank}(\tilde{\mathbf{G}}^{[j]}), \quad (\text{B.24})$$

where

$$\tilde{\mathbf{G}}^{[j]} \triangleq \left[\begin{array}{c|c} (\tilde{\mathbf{Q}}_{j^{i_1}})^T & \{\mathbf{Q}_{j^{i_1}}^T \boldsymbol{\omega}_{j^{i_2}}\}_{j' \in (\mathcal{S}_K \setminus \mathcal{S}_m) \cup \{j\}} \\ \hline (\tilde{\mathbf{Q}}_{j^{i_2}})^T & \mathbf{0} \end{array} \right], \quad (\text{B.25})$$

and $\tilde{\mathbf{Q}}_{j^{i_1}}$ and $\tilde{\mathbf{Q}}_{j^{i_2}}$ are respectively the submatrices of $\mathbf{Q}_{j^{i_1}}$ and $\mathbf{Q}_{j^{i_2}}$ including their first $K - m$ rows. Hence, it suffices to show $\tilde{\mathbf{G}}^{[j]}$ is full rank. To do so, we note that $\tilde{\mathbf{Q}}_{j^{i_2}}$ is a $(K - m) \times (K - m)$ matrix with $\text{rank}(\tilde{\mathbf{Q}}_{j^{i_2}}) = \text{rank}(\mathbf{Q}_{j^{i_2}}) = K - m$. If we show that the matrix $[\mathbf{Q}_{j^{i_1}}^T \boldsymbol{\omega}_{j^{i_2}}]_{j' \in (\mathcal{S}_K \setminus \mathcal{S}_m) \cup \{j\}}$ is also a square full rank matrix of size $(K - m + 1) \times (K - m + 1)$, then using Lemma 2, it immediately follows that $\tilde{\mathbf{G}}^{[j]}$ is full rank. Now, we rewrite $[\mathbf{Q}_{j^{i_1}}^T \boldsymbol{\omega}_{j^{i_2}}]_{j' \in (\mathcal{S}_K \setminus \mathcal{S}_m) \cup \{j\}}$ as:

$$[\mathbf{Q}_{j^{i_1}}^T \boldsymbol{\omega}_{j^{i_2}}]_{j' \in (\mathcal{S}_K \setminus \mathcal{S}_m) \cup \{j\}} = (\mathbf{C}^{[i_1|\mathcal{S}_m]})^T [\mathbf{D}_{j^{i_1}} \boldsymbol{\omega}_{j^{i_2}}]_{j' \in (\mathcal{S}_K \setminus \mathcal{S}_m) \cup \{j\}}. \quad (\text{B.26})$$

Since the matrices are square, we have

$$\det([\mathbf{Q}_{j^{i_1}}^T \boldsymbol{\omega}_{j^{i_2}}]_{j' \in (\mathcal{S}_K \setminus \mathcal{S}_m) \cup \{j\}}) = \det(\mathbf{C}^{[i_1|\mathcal{S}_m]}) \cdot \det([\mathbf{D}_{j^{i_1}} \boldsymbol{\omega}_{j^{i_2}}]_{j' \in (\mathcal{S}_K \setminus \mathcal{S}_m) \cup \{j\}}), \quad (\text{B.27})$$

and since $\mathbf{C}^{[i_1|\mathcal{S}_m]}$ is full rank almost surely, $\det(\mathbf{C}^{[i_1|\mathcal{S}_m]}) \neq 0$. Thus, it remains to show $[\mathbf{D}_{j^{i_1}} \boldsymbol{\omega}_{j^{i_2}}]_{j' \in (\mathcal{S}_K \setminus \mathcal{S}_m) \cup \{j\}}$ is full rank. Using the same argument as in Appendix B.1, one can write

$$\boldsymbol{\omega}_{j^{i_2}} = a_{j^{i_2}} \mathbf{D}_{j^{i_2}}^{-1} \mathbf{n}^{[i_2]}, \quad (\text{B.28})$$

APPENDIX B: PROOFS OF LINEAR INDEPENDENCE

where $a_{j'i_2}$ is a nonzero scalar. Therefore,

$$\begin{aligned}
\text{rank}([\mathbf{D}_{j'i_1} \boldsymbol{\omega}_{j'i_2}]_{j' \in (\mathcal{S}_K \setminus \mathcal{S}_m) \cup \{j\}}) &= \text{rank}([a_{j'i_2} \mathbf{D}_{j'i_1} \mathbf{D}_{j'i_2}^{-1} \mathbf{n}^{[i_2]}]_{j' \in (\mathcal{S}_K \setminus \mathcal{S}_m) \cup \{j\}}) \\
&\stackrel{(a)}{=} \text{rank}([\mathbf{D}_{j'i_1} \mathbf{D}_{j'i_2}^{-1} \mathbf{n}^{[i_2]}]_{j' \in (\mathcal{S}_K \setminus \mathcal{S}_m) \cup \{j\}}) \\
&\stackrel{(b)}{=} \text{rank}\left(\begin{bmatrix} h^{[j'i_1]}(t) \\ h^{[j'i_2]}(t) \end{bmatrix}_{\substack{1 \leq t \leq K-m+1 \\ j' \in (\mathcal{S}_K \setminus \mathcal{S}_m) \cup \{j\}}}\right) \\
&\stackrel{(c)}{=} K - m + 1, \tag{B.29}
\end{aligned}$$

where (a) follows from the fact that scaling the columns of a matrix by nonzero factors ($a_{j'i_2}$'s) will not change its rank; (b) follows from the fact that scaling the rows of a matrix by nonzero factors (elements of $\mathbf{n}^{[i_2]}$) will not change its rank; and (c) is true since $\frac{h^{[j'i_1]}(t)}{h^{[j'i_2]}(t)}$'s are i.i.d. for $1 \leq t \leq K - m + 1$ and $j' \in (\mathcal{S}_K \setminus \mathcal{S}_m) \cup \{j\}$.

Lemma 2. *Let $\mathbf{A} = [a_{ij}]_{m \times m}$ and $\mathbf{B} = [b_{ij}]_{n \times n}$ be two square matrices which are full rank almost surely and let $\mathbf{C} = [c_{ij}]_{m \times n}$ be an arbitrary matrix. Then the following matrix is full rank almost surely:*

$$\mathbf{D} = \left[\begin{array}{c|c} \mathbf{C} & \mathbf{A} \\ \hline \mathbf{B} & \mathbf{O} \end{array} \right]. \tag{B.30}$$

Proof. Denote by \mathbf{a}_j , \mathbf{b}_j , and \mathbf{d}_j the j 'th columns of \mathbf{A} , \mathbf{B} , and \mathbf{D} , respectively. Assume that

$$\sum_{j=1}^{m+n} \alpha_j \mathbf{d}_j = \mathbf{0}_{(m+n) \times 1}, \tag{B.31}$$

for some $\alpha_1, \alpha_2, \dots, \alpha_{m+n} \in \mathbb{C}$. Then, since $d_{ij} = 0$ for $m+1 \leq i \leq m+n$ and $n+1 \leq j \leq m+n$, one can write $\sum_{j=1}^n \alpha_j \mathbf{b}_j = \mathbf{0}_{n \times 1}$ and since \mathbf{B} is full rank almost surely, we have $\alpha_j = 0$, $1 \leq j \leq n$. This together with (B.31) yields $\sum_{j=n+1}^{m+n} \alpha_j \mathbf{d}_j = \mathbf{0}_{(m+n) \times 1}$. Considering the first m elements of these columns, it follows that $\sum_{j=n+1}^{m+n} \alpha_j \mathbf{a}_{j-n} = \mathbf{0}_{m \times 1}$ and since \mathbf{A} is full rank almost surely, we have $\alpha_j = 0$, $n+1 \leq j \leq m+n$. \square

Appendix C

Achievable DoF Limits for K -user IC and $2 \times K$ X Channel with Delayed CSIT

In this appendix, we show that

$$\lim_{K \rightarrow \infty} \text{DoF}_1^{\text{IC}}(K) = \frac{4}{6 \ln 2 - 1}, \quad (\text{C.1})$$

$$\lim_{K \rightarrow \infty} \text{DoF}_1^{\text{X}}(2, K) = \frac{1}{\ln 2}. \quad (\text{C.2})$$

Regarding (3.7), (3.8) and (3.10), it suffices to show that

$$\lim_{K \rightarrow \infty} \Psi(K) = \frac{21}{16} - \frac{3}{2} \ln 2. \quad (\text{C.3})$$

$$\lim_{K \rightarrow \infty} \Phi(K) = 1 - \ln 2. \quad (\text{C.4})$$

where

$$\Psi(K) \triangleq \sum_{\ell_1=0}^{K-3} \frac{(K - \ell_1 - 1)(3\ell_1^2 + \ell_1 - 1)}{2(K - \ell_1)(4\ell_1^2 - 1)} \prod_{\ell_2=\ell_1+1}^{K-2} \frac{\ell_2}{2\ell_2 + 1}, \quad (\text{C.5})$$

$$\Phi(K) \triangleq \sum_{\ell_1=0}^{K-2} \frac{(K - \ell_1 - 1)(\ell_1 + 1)}{(K - \ell_1)(2\ell_1 + 1)} \prod_{\ell_2=\ell_1+1}^{K-1} \frac{\ell_2}{2\ell_2 + 1}. \quad (\text{C.6})$$

APPENDIX C: ACHIEVABLE DOF LIMITS

To do so, for any integers $K, p \geq 0$, define the functions $\Gamma_p(K)$ and $\Lambda_p(K)$ as

$$\Gamma_p(K) \triangleq \sum_{\ell=0}^{K-p} \frac{K - \ell - 1}{(K - \ell)2^{K-\ell}}, \quad (\text{C.7})$$

$$\Lambda_p(K) \triangleq \sum_{\ell=0}^{K-p} \frac{\ell(K - \ell - 1)}{K(K - \ell)2^{K-\ell}}. \quad (\text{C.8})$$

Using $\sum_{n=1}^{\infty} \frac{1}{n2^n} = \ln 2$, $\sum_{n=1}^{\infty} \frac{n}{2^n} = 2$, and $\sum_{n=1}^{\infty} \frac{1}{2^n} = 1$, it is easily verified that, for any integer $p \geq 0$,

$$\lim_{K \rightarrow \infty} \Gamma_p(K) = \lim_{K \rightarrow \infty} \Lambda_p(K) = -\ln 2 + 2^{1-p} + \sum_{n=1}^{p-1} \frac{1}{n2^n}. \quad (\text{C.9})$$

In specific,

$$\lim_{K \rightarrow \infty} \Gamma_2(K) = \lim_{K \rightarrow \infty} \Lambda_2(K) = 1 - \ln 2, \quad (\text{C.10})$$

$$\lim_{K \rightarrow \infty} \Gamma_3(K) = \lim_{K \rightarrow \infty} \Lambda_3(K) = \frac{7}{8} - \ln 2. \quad (\text{C.11})$$

Now, using the following two lemmas together with the Squeeze Theorem, (C.3) and (C.4) are immediate.

Lemma 3. *The following inequalities hold for $K \geq 3$:*

$$\frac{3K}{2K-3} \Lambda_3(K) < \Psi(K) < \frac{3}{2} \Gamma_3(K) + \frac{K-2}{5(K-1)2^K}. \quad (\text{C.12})$$

Proof. (i) Upper bound:

$$\begin{aligned} \Psi(K) &= \sum_{\ell_1=0}^{K-3} \frac{(K - \ell_1 - 1)(3\ell_1^2 + \ell_1 - 1)}{2(K - \ell_1)(4\ell_1^2 - 1)} \prod_{\ell_2=\ell_1+1}^{K-2} \frac{\ell_2}{2\ell_2 + 1} \\ &= \sum_{\ell_1=0}^{K-3} \frac{(K - \ell_1 - 1)(3\ell_1^2 + \ell_1 - 1)(\ell_1 + 1)}{2(K - \ell_1)(4\ell_1^2 - 1)(2\ell_1 + 3)} \prod_{\ell_2=\ell_1+2}^{K-2} \frac{\ell_2}{2\ell_2 + 1} \\ &= \frac{K-1}{6K} \prod_{\ell_2=2}^{K-2} \frac{\ell_2}{2\ell_2 + 1} + \frac{K-2}{5(K-1)} \prod_{\ell_2=3}^{K-2} \frac{\ell_2}{2\ell_2 + 1} \\ &\quad + \sum_{\ell_1=2}^{K-3} \frac{(K - \ell_1 - 1)(3\ell_1^2 + \ell_1 - 1)(\ell_1 + 1)}{2(K - \ell_1)(4\ell_1^2 - 1)(2\ell_1 + 3)} \prod_{\ell_2=\ell_1+2}^{K-2} \frac{\ell_2}{2\ell_2 + 1} \end{aligned}$$

APPENDIX C: ACHIEVABLE DOF LIMITS

$$\begin{aligned}
& \stackrel{(a)}{<} \frac{K-2}{5 \times 2^4(K-1)} \prod_{\ell_2=3}^{K-2} \frac{\ell_2}{2\ell_2+1} + \left\{ \frac{3(K-1)}{2^4 K} \prod_{\ell_2=2}^{K-2} \frac{\ell_2}{2\ell_2+1} + \frac{3(K-2)}{2^4(K-1)} \prod_{\ell_2=3}^{K-2} \frac{\ell_2}{2\ell_2+1} \right. \\
& \quad \left. + \sum_{\ell_1=2}^{K-3} \frac{3(K-\ell_1-1)}{2^4(K-\ell_1)} \prod_{\ell_2=\ell_1+2}^{K-2} \frac{\ell_2}{2\ell_2+1} \right\} \\
& = \frac{K-2}{5 \times 2^4(K-1)} \prod_{\ell_2=3}^{K-2} \frac{\ell_2}{2\ell_2+1} + \sum_{\ell_1=0}^{K-3} \frac{3(K-\ell_1-1)}{2^4(K-\ell_1)} \prod_{\ell_2=\ell_1+2}^{K-2} \frac{\ell_2}{2\ell_2+1} \\
& \stackrel{(b)}{<} \frac{K-2}{5(K-1)2^K} + \frac{3}{2} \sum_{\ell_1=0}^{K-3} \frac{K-\ell_1-1}{(K-\ell_1)2^{K-\ell_1}} \\
& = \frac{3}{2} \Gamma_3(K) + \frac{K-2}{5(K-1)2^K}, \tag{C.13}
\end{aligned}$$

where (a) follows from the fact that $\frac{(3\ell_1^2+\ell_1-1)(\ell_1+1)}{(4\ell_1^2-1)(2\ell_1+3)} < \frac{3}{8}$ for $\ell_1 \geq 2$ together with inequality $\frac{1}{6} < \frac{3}{16}$, and (b) is valid since $\frac{\ell_2}{2\ell_2+1} < \frac{1}{2}$ for $\ell_2 \geq 2$.

(ii) Lower bound:

$$\begin{aligned}
\Psi(K) &= \sum_{\ell_1=0}^{K-3} \frac{(K-\ell_1-1)(3\ell_1^2+\ell_1-1)}{2(K-\ell_1)(4\ell_1^2-1)} \prod_{\ell_2=\ell_1+1}^{K-2} \frac{\ell_2}{2\ell_2+1} \\
&= \sum_{\ell_1=0}^{K-3} \frac{(K-\ell_1-1)(3\ell_1^2+\ell_1-1)(\ell_1+1)}{2(2K-3)(K-\ell_1)(4\ell_1^2-1)} \prod_{\ell_2=\ell_1+2}^{K-2} \frac{\ell_2}{2\ell_2-1} \\
&\stackrel{(a)}{>} \frac{3K}{2K-3} \sum_{\ell_1=0}^{K-3} \frac{\ell_1(K-\ell_1-1)}{K(K-\ell_1)2^{K-\ell_1}} \\
&= \frac{3K}{2K-3} \Lambda_3(K), \tag{C.14}
\end{aligned}$$

where (a) follows from the fact that $\frac{(3\ell_1^2+\ell_1-1)(\ell_1+1)}{4\ell_1^2-1} > \frac{3}{4}\ell_1$ for $\ell_1 \geq 0$, and $\frac{\ell_2}{2\ell_2-1} > \frac{1}{2}$ for $\ell_2 \geq 2$. \square

Lemma 4. *The following inequalities hold for $K \geq 2$:*

$$\frac{2K}{2K-1} \Lambda_2(K) < \Phi(K) < \Gamma_3(K) + \frac{(K-1)^2}{2(2K-1)(2K-3)} + \frac{K-1}{15K2^K}. \tag{C.15}$$

APPENDIX C: ACHIEVABLE DOF LIMITS

Proof. (i) Upper bound:

$$\begin{aligned}
\Phi(K) &= \sum_{\ell_1=0}^{K-2} \frac{(K-\ell_1-1)(\ell_1+1)}{(K-\ell_1)(2\ell_1+1)} \prod_{\ell_2=\ell_1+1}^{K-1} \frac{\ell_2}{2\ell_2+1} \\
&= \frac{(K-1)^2}{2(2K-1)(2K-3)} + \sum_{\ell_1=0}^{K-3} \frac{(K-\ell_1-1)(\ell_1+1)^2(\ell_1+2)}{(K-\ell_1)(2\ell_1+1)(2\ell_1+3)(2\ell_1+5)} \prod_{\ell_2=\ell_1+3}^{K-1} \frac{\ell_2}{2\ell_2+1} \\
&\stackrel{(a)}{<} \frac{(K-1)^2}{2(2K-1)(2K-3)} + \frac{2(K-1)}{15K} \prod_{\ell_2=3}^{K-1} \frac{\ell_2}{2\ell_2+1} + \sum_{\ell_1=1}^{K-3} \frac{K-\ell_1-1}{2^3(K-\ell_1)} \prod_{\ell_2=\ell_1+3}^{K-1} \frac{\ell_2}{2\ell_2+1} \\
&= \frac{(K-1)^2}{2(2K-1)(2K-3)} + \frac{(K-1)}{15 \times 2^3 K} \prod_{\ell_2=3}^{K-1} \frac{\ell_2}{2\ell_2+1} + \sum_{\ell_1=0}^{K-3} \frac{K-\ell_1-1}{2^3(K-\ell_1)} \prod_{\ell_2=\ell_1+3}^{K-1} \frac{\ell_2}{2\ell_2+1} \\
&\stackrel{(b)}{<} \frac{(K-1)^2}{2(2K-1)(2K-3)} + \frac{(K-1)}{15K2^K} + \sum_{\ell_1=0}^{K-3} \frac{K-\ell_1-1}{(K-\ell_1)2^{K-\ell_1}} \\
&= \Gamma_3(K) + \frac{(K-1)^2}{2(2K-1)(2K-3)} + \frac{K-1}{15K2^K}, \tag{C.16}
\end{aligned}$$

where (a) follows from the fact that $\frac{(\ell_1+1)^2(\ell_1+2)}{(2\ell_1+1)(2\ell_1+3)(2\ell_1+5)} < \frac{1}{8}$ for $\ell_1 \geq 1$, and (b) is true since $\frac{\ell_2}{2\ell_2+1} < \frac{1}{2}$ for $\ell_2 \geq 3$.

(ii) Lower bound:

$$\begin{aligned}
\Phi(K) &= \sum_{\ell_1=0}^{K-2} \frac{(K-\ell_1-1)(\ell_1+1)}{(K-\ell_1)(2\ell_1+1)} \prod_{\ell_2=\ell_1+1}^{K-1} \frac{\ell_2}{2\ell_2+1} \\
&= \sum_{\ell_1=0}^{K-2} \frac{(K-\ell_1-1)(\ell_1+1)^2}{(2K-1)(K-\ell_1)(2\ell_1+1)} \prod_{\ell_2=\ell_1+2}^{K-1} \frac{\ell_2}{2\ell_2-1} \\
&\stackrel{(a)}{>} \frac{2K}{2K-1} \sum_{\ell_1=0}^{K-2} \frac{\ell_1(K-\ell_1-1)}{K(K-\ell_1)2^{K-\ell_1}} \\
&= \frac{2K}{2K-1} \Lambda_2(K), \tag{C.17}
\end{aligned}$$

where (a) follows from the fact that $\frac{(\ell_1+1)^2}{2\ell_1+1} > \frac{1}{2}\ell_1$ for $\ell_1 \geq 0$, and $\frac{\ell_2}{2\ell_2-1} > \frac{1}{2}$ for $\ell_2 \geq 2$. \square

Bibliography

- [1] M. J. Abdoli, A. Ghasemi, and A. K. Khandani. On the degrees of freedom of K -user SISO interference and X channels with delayed CSIT. *Submitted to Information Theory, IEEE Transactions on, Available online at: Arxiv preprint arXiv:1109.4314*, 2011.
- [2] M. J. Abdoli, A. Ghasemi, and A. K. Khandani. On the degrees of freedom of SISO interference and X channels with delayed CSIT. In *Communication, Control, and Computing (Allerton), 2011 49th Annual Allerton Conference on*, pages 625–632, 2011.
- [3] M. J. Abdoli, A. Ghasemi, and A. K. Khandani. On the degrees of freedom of three-user MIMO broadcast channel with delayed CSIT. In *Information Theory, 2011. ISIT 2011. IEEE International Symposium on*, pages 341–345, 2011.
- [4] M. J. Abdoli, A. Ghasemi, and A. K. Khandani. Full-duplex transmitter cooperation, feedback, and the degrees of freedom of SISO Gaussian interference and X channels. In *Information Theory, 2012. ISIT 2012. IEEE International Symposium on*, pages 3120–3124, 2012.
- [5] M. J. Abdoli, A. Ghasemi, and A. K. Khandani. Interference and X networks with noisy cooperation and feedback. *Submitted to Information Theory, IEEE Transactions on, Available online at: Arxiv preprint arXiv:1201.5805*, 2012.
- [6] R. Ahlswede. The capacity region of a channel with two senders and two receivers. *The Annals of Probability*, 2(5):805–814, 1974.

BIBLIOGRAPHY

- [7] V. S. Annapureddy and V. V. Veeravalli. Gaussian interference networks: Sum capacity in the low-interference regime and new outer bounds on the capacity region. *Information Theory, IEEE Transactions on*, 55(7):3032–3050, 2009.
- [8] S. R. Bhaskaran. Gaussian broadcast channel with feedback. *Information Theory, IEEE Transactions on*, 54(11):5252–5257, 2008.
- [9] M. V. Burnashev. Data transmission over a discrete channel with feedback. Random transmission time. *Problemy peredachi informatsii*, 12(4):10–30, 1976.
- [10] V. R. Cadambe and S. A. Jafar. Interference alignment and degrees of freedom of the K -user interference channel. *Information Theory, IEEE Transactions on*, 54(8):3425–3441, 2008.
- [11] V. R. Cadambe and S. A. Jafar. Degrees of freedom of wireless networks with relays, feedback, cooperation, and full duplex operation. *Information Theory, IEEE Transactions on*, 55(5):2334–2344, 2009.
- [12] V. R. Cadambe and S. A. Jafar. Interference alignment and the degrees of freedom of wireless X networks. *Information Theory, IEEE Transactions on*, 55(9):3893–3908, 2009.
- [13] Y. Cao and B. Chen. An achievable rate region for interference channels with conferencing. In *Information Theory, 2007. ISIT 2007. IEEE International Symposium on*, pages 1251–1255, 2007.
- [14] A. Carleial. A case where interference does not reduce capacity (corresp.). *Information Theory, IEEE Transactions on*, 21(5):569–570, 1975.
- [15] T. M. Cover and C. Leung. An achievable rate region for the multiple-access channel with feedback. *Information Theory, IEEE Transactions on*, 27(3):292–298, 1981.
- [16] T. M. Cover and J. A. Thomas. *Elements of information theory*. Wiley, New York, 2 edition, 2006.

BIBLIOGRAPHY

- [17] R. H. Etkin and E. Ordentlich. The degrees-of-freedom of the K -user Gaussian interference channel is discontinuous at rational channel coefficients. *Information Theory, IEEE Transactions on*, 55(11):4932–4946, 2009.
- [18] R. H. Etkin, D. Tse, and H. Wang. Gaussian interference channel capacity to within one bit. *Information Theory, IEEE Transactions on*, 54(12):5534–5562, 2008.
- [19] G. Forney Jr. Exponential error bounds for erasure, list, and decision feedback schemes. *Information Theory, IEEE Transactions on*, 14(2):206–220, 1968.
- [20] R. G. Gallager and B. Nakiboglu. Variations on a theme by Schalkwijk and Kailath. *Information Theory, IEEE Transactions on*, 56(1):6–17, 2010.
- [21] A. Ghasemi, M. J. Abdoli, and A. K. Khandani. On the degrees of freedom of MIMO X channel with delayed CSIT. In *Information Theory, 2012. ISIT 2012. IEEE International Symposium on*, pages 1892–1896, 2012.
- [22] A. Ghasemi, A. S. Motahari, and A. K. Khandani. Interference alignment for the MIMO interference channel with delayed local CSIT. *Arxiv preprint arXiv:1102.5673*, 2011.
- [23] A. Ghasemi, A. S. Motahari, and A. K. Khandani. On the degrees of freedom of X channel with delayed CSIT. In *Information Theory, 2011. ISIT 2011. IEEE International Symposium on*, pages 909–912, 2011.
- [24] T. Han and K. Kobayashi. A new achievable rate region for the interference channel. *Information Theory, IEEE Transactions on*, 27(1):49–60, 1981.
- [25] A. Host-Madsen. Capacity bounds for cooperative diversity. *Information Theory, IEEE Transactions on*, 52(4):1522–1544, 2006.
- [26] A. Host-Madsen and A. Nosratinia. The multiplexing gain of wireless networks. In *Information Theory, 2005. ISIT 2005. IEEE International Symposium on*, pages 2065–2069, 2005.

BIBLIOGRAPHY

- [27] C. Huang, S. A. Jafar, S. Shamai, and S. Vishwanath. On degrees of freedom region of MIMO networks without CSIT. *Arxiv preprint arXiv:0909.4017*, 2009.
- [28] S. A. Jafar and A. J. Goldsmith. Isotropic fading vector broadcast channels: The scalar upper bound and loss in degrees of freedom. *Information Theory, IEEE Transactions on*, 51(3):848–857, 2005.
- [29] S. A. Jafar and S. Shamai. Degrees of freedom region of the MIMO X channel. *Information Theory, IEEE Transactions on*, 54(1):151–170, 2008.
- [30] G. Kramer. Feedback strategies for white Gaussian interference networks. *Information Theory, IEEE Transactions on*, 48(6):1423–1438, 2002.
- [31] G. Kramer. Correction to “feedback strategies for white Gaussian interference networks,” and a capacity theorem for Gaussian interference channels with feedback. *Information Theory, IEEE Transactions on*, 50(6):1373–1374, 2004.
- [32] M. A. Maddah-Ali, A. S. Motahari, and A. K. Khandani. Communication over MIMO X channels: Interference alignment, decomposition, and performance analysis. *Information Theory, IEEE Transactions on*, 54(8):3457–3470, 2008.
- [33] M. A. Maddah-Ali and D. Tse. Completely stale transmitter channel state information is still very useful. In *Communication, Control, and Computing (Allerton), 2010 48th Annual Allerton Conference on*, pages 1188–1195, 2010.
- [34] M. A. Maddah-Ali and D. Tse. Completely stale transmitter channel state information is still very useful. *Arxiv preprint arXiv:1010.1499v2*, 2010.
- [35] H. Maleki, S. A. Jafar, and S. Shamai. Retrospective interference alignment over interference networks. *Selected Topics in Signal Processing, IEEE Journal of*, 6(3):228–240, 2012.
- [36] A. S. Motahari and A. K. Khandani. Capacity bounds for the Gaussian interference channel. *Information Theory, IEEE Transactions on*, 55(2):620–643, 2009.

BIBLIOGRAPHY

- [37] L. Ozarow. An achievable region and outer bound for the Gaussian broadcast channel with feedback (corresp.). *Information Theory, IEEE Transactions on*, 30(4):667–671, 1984.
- [38] L. Ozarow. The capacity of the white Gaussian multiple access channel with feedback. *Information Theory, IEEE Transactions on*, 30(4):623–629, 1984.
- [39] V. M. Prabhakaran and P. Viswanath. Interference channels with source cooperation. *Information Theory, IEEE Transactions on*, 57(1):156–186, 2011.
- [40] H. Sato. The capacity of the Gaussian interference channel under strong interference (corresp.). *Information Theory, IEEE Transactions on*, 27(6):786–788, 1981.
- [41] J. Schalkwijk. A coding scheme for additive noise channels with feedback–II: Band-limited signals. *Information Theory, IEEE Transactions on*, 12(2):183–189, 1966.
- [42] J. Schalkwijk and T. Kailath. A coding scheme for additive noise channels with feedback–I: No bandwidth constraint. *Information Theory, IEEE Transactions on*, 12(2):172–182, 1966.
- [43] X. Shang, G. Kramer, and B. Chen. A new outer bound and the noisy-interference sum-rate capacity for Gaussian interference channels. *Information Theory, IEEE Transactions on*, 55(2):689–699, 2009.
- [44] C. E. Shannon. The zero error capacity of a noisy channel. *Information Theory, IRE Transactions on*, 2(3):8–19, 1956.
- [45] C. E. Shannon. Two-way communication channels. In *Proc. 4th Berkeley Symposium on Mathematical Statistics and Probability*, volume 1, pages 611–644, 1961.
- [46] C. E. Shannon and W. Weaver. The mathematical theory of communication. *Bell System Technical Journal*, 27:379–423, 1948.
- [47] O. Shayevitz and M. Wigger. On the capacity of the discrete memoryless broadcast channel with feedback. *Arxiv preprint arXiv:1012.6012*, 2010.

BIBLIOGRAPHY

- [48] C. Suh and D. Tse. Feedback capacity of the Gaussian interference channel to within 2 bits. *Information Theory, IEEE Transactions on*, 57(5):2667–2685, 2011.
- [49] R. Tandon, S. Mohajer, and H. V. Poor. On the symmetric feedback capacity of the K -user cyclic Z-interference channel. *Arxiv preprint arXiv:1109.1507*, 2011.
- [50] R. Tandon, S. Mohajer, H. V. Poor, and S. Shamai. On interference networks with feedback and delayed CSI. *Arxiv preprint arXiv:1109.5373*, 2011.
- [51] R. Tandon, S. Mohajer, H. V. Poor, and S. Shamai. On X-channels with feedback and delayed CSI. *Arxiv preprint arXiv:1201.6313*, 2012.
- [52] R. Tandon and S. Ulukus. Dependence balance based outer bounds for Gaussian networks with cooperation and feedback. *Information Theory, IEEE Transactions on*, 57(7):4063–4086, 2011.
- [53] D. Tse and R. Yates. Fading broadcast channels with state information at the receivers. *Arxiv preprint arXiv:0904.3165*, 2009.
- [54] C. S. Vaze and M. K. Varanasi. The degrees of freedom region of the MIMO interference channel with Shannon feedback. *Arxiv preprint arXiv:1109.5779*, 2011.
- [55] C. S. Vaze and M. K. Varanasi. The degrees of freedom region of the two-user MIMO broadcast channel with delayed CSIT. In *Information Theory, 2011. ISIT 2011. IEEE International Symposium on*, pages 331–335, 2011.
- [56] C. S. Vaze and M. K. Varanasi. The degree-of-freedom regions of MIMO broadcast, interference, and cognitive radio channels with no CSIT. *Information Theory, IEEE Transactions on*, 58(8):5354–5374, 2012.
- [57] C. S. Vaze and M. K. Varanasi. The degrees of freedom region and interference alignment for the MIMO interference channel with delayed CSIT. *Information Theory, IEEE Transactions on*, 58(7):4396–4417, 2012.
- [58] R. Venkataramanan and S. S. Pradhan. An achievable rate region for the broadcast channel with feedback. *Arxiv preprint arXiv:1105.2311*, 2011.

BIBLIOGRAPHY

- [59] H. Weingarten, Y. Steinberg, and S. Shamai. The capacity region of the Gaussian multiple-input multiple-output broadcast channel. *Information Theory, IEEE Transactions on*, 52(9):3936–3964, 2006.
- [60] A. D. Wyner. Shannon-theoretic approach to a Gaussian cellular multiple-access channel. *Information Theory, IEEE Transactions on*, 40(6):1713–1727, 1994.
- [61] S. Yang, M. Kobayashi, P. Piantanida, and S. Shamai. Secrecy degrees of freedom of MIMO broadcast channels with delayed CSIT. *Arxiv preprint arXiv:1112.2306*, 2011.
- [62] S. Yang, P. Piantanida, M. Kobayashi, and S. Shamai. On the secrecy degrees of freedom of multi-antenna wiretap channels with delayed CSIT. In *Information Theory, 2011. ISIT 2011. IEEE International Symposium on*, pages 2866–2870, 2011.
- [63] S. Yang and D. Tuninetti. Interference channel with generalized feedback (a.k.a. with source cooperation): Part I: Achievable region. *Information Theory, IEEE Transactions on*, 57(5):2686–2710, 2011.
- [64] X. Yi and D. Gesbert. Precoding methods for MISO broadcast channel with delayed CSIT. *Arxiv preprint arXiv:1207.2103*, 2012.
- [65] Y. Zhu and D. Guo. Ergodic fading Z-interference channels without state information at transmitters. *Information Theory, IEEE Transactions on*, 57(5):2627–2647, 2011.
- [66] Y. Zhu and D. Guo. The degrees of freedom of isotropic MIMO interference channels without state information at the transmitters. *Information Theory, IEEE Transactions on*, 58(1):341–352, 2012.