

Techno -Economic Study of Renewable Energy Integration in the Upstream Oil Supply Chain (USOSC)

By

Salah Abureden

A thesis

presented to the University of Waterloo

in fulfillment of the

thesis requirement for the degree of

Master of Applied Science

in

Chemical Engineering

Waterloo, Ontario, Canada, 2013

© Salah Abureden 2013

AUTHOR'S DECLARATION

I hereby declare that I am the sole author of this thesis. This is a true copy of the thesis, including any required final revisions, as accepted by my examiners.

I understand that my thesis may be made electronically available to the public.

Abstract

The production of oil requires tremendous amounts of energy consumption through a distributed combustion network of processes along the oil supply chain spectrum. The consequences of fossil-based fuel combustion processes are the generation of Greenhouse Gas (GHG) emissions and hazardous wastewater, which have adverse environmental effects. Potential mitigation options of GHG emissions are the application of renewable and alternative energy sources. This research deals with integrating the upstream oil supply chain with renewable power generation systems in order to assess the impact of energy demand, and CO₂ emissions on the efficiency of oil operations and environment . The main focus in this thesis is to evaluate the solar energy alternative for producing part of the energy requirements in the upstream oil supply chain. The output from the research will provide an optimal mix of energy generation in the upstream oil industry in order to comply with CO₂ constraints, while sustaining target production plans.

An analysis of GHG emission sources and their associated flow rates in the upstream oil supply chain mainly CO₂ is discussed in this study. An investigation of replacement of energy supply for some non-critical operations from fossil fuels or other conventional sources to green renewable energy sources mainly from solar energy is also carried out with special focus on enhanced oil recovery operations. An analysis of different types of solar energy and identification of the best type of solar energy technologies that best matches the oil and gas industry is investigated in this study. The thesis will also identify the challenges for solar energy integration including irradiation levels and weather conditions in addition to policy regulations

Acknowledgements

I would like to express my sincere thanks and gratitude to Professor Bruce Hellinga/ associate dean for graduate studies, Professor Leonardo Simon/ associate chair for graduate studies and Mrs. Judy Caron/graduate studies coordinator for their support and encouragement

I would like also to express my sincere thanks and appreciation to Professor Zhongwei Chen and Professor Ting Tsui for their valuable advices and contribution in this thesis

Finally, deep thanks to my supervisor, Professor Ali Elkamel for all what I have learnt from him and for his guidance and encouragement during all the stages of the thesis

Dedication

To the believers in freedom and justice everywhere in the world

Contents

List of figures.....	XI
list of tables.....	XIV
1 Survey of 1 crude oil operations	2
1.1 Crude oil and natural gas	2
1.1.1 Crude Oil.....	2
1.1.2 Natural gas	2
1.1.3 Condensates	2
1.1.4 The reservoir	3
1.2 USOSC operations	4
1.2.1 Background.....	4
1.3 Main processes.....	6
1.3.1 Wellheads.....	6
1.3.2 Manifolds gathering	7
1.3.3 Separation	8
1.3.4 Gas compression	9
1.3.5 Storage	9
1.3.6 Oil transport	10
1.3.7 Reservoir and Wellheads	11
1.3.8 Exploration and Drilling	11
1.3.9 The Well.....	11
1.3.10 Artificial lift	14
1.4 Energy in USOSC.....	16

1.4.1	Energy consumption sources	16
1.4.2	Energy return on energy invested (EROEI)	17
2	Greenhouse Gas Emissions	18
2.1	Investigated gases	18
2.2	Greenhouse gas effect	18
2.3	Carbon dioxide emission projection	19
2.4	GHG in USOSC	20
2.4.1	Main sources	20
2.4.2	Exploration phase.....	22
2.4.3	Well development phase	22
2.4.4	Casing	24
2.4.5	Completing the well and final testing	25
2.4.6	Fracturing	25
2.4.7	Flaring	25
2.4.8	Venting.....	25
2.4.9	Compressor engines	26
2.4.10	Primary production phase	26
2.4.11	Secondary and territory recovery	26
2.4.12	Well site visits.....	27
2.4.13	Separator and dehydrator	27
2.4.14	Wastewater disposal.....	28
2.4.15	Other facilities.....	28
2.4.16	Leaks	28
2.4.17	Accidental release	28

2.5	GHG assessment/quantification.....	29
2.5.1	Un-certainty	29
2.5.2	Other factors.....	31
2.5.3	Typical CO ₂ distribution in USOSC.....	32
2.5.4	Study example.....	32
2.5.5	Accurate estimate of GHG.....	33
3	Renewable energy	34
3.1	Hydropower	35
3.2	Biofuels.....	36
3.3	Geothermal energy.....	37
3.4	Ocean energy	38
3.5	Wind energy.....	38
4	Solar energy	40
4.1	Background.....	40
4.2	Theory.....	43
4.3	Common use of solar power	44
4.4	Advantages of solar energy.....	46
4.5	Growth	47
4.6	Solar energy technologies.....	48
4.7	Solar energy potential	50
4.8	Solar radiations	52
4.8.1	Effective radiations	52
4.8.2	Radiation maps.....	54
4.9	Solar energy economics	54

4.9.1	Cost of solar power	59
4.10	Future growth.....	63
4.11	Challenges.....	64
4.11.1	Technical.....	65
4.11.2	Economic	65
4.11.3	Institutional	65
5	Solar energy in USOSC	68
5.1	Integration areas.....	68
5.2	Applications	68
5.2.1	Telecommunication.....	69
5.2.2	Remot terminal units and SCADA.....	70
5.2.3	Cathodic protection.....	70
5.3	Solar-Steam for EOR	71
5.3.1	Solar-steam projects.....	73
6	Case Study	75
6.1	Set one.....	75
6.2	Set two (assumptions).....	76
6.3	Selection of process and solar technology	79
6.3.1	Selected process and solar type.....	79
6.4	CPS vs. large scale PV.....	81
6.5	Selection of CSP type	83
6.5.1	Technical comparison	83
6.5.2	Financial comparison.....	84
6.6	Location	86

6.6.1	Selection criteria for the location	87
6.7	Assumptions.....	87
6.8	Calculations.....	90
6.8.1	Methodology	90
6.8.2	Emission factors.....	91
6.8.3	Scenario One.....	91
6.8.4	Scenario Two	92
6.8.5	Scenario Three	95
6.8.6	Summary of the results of the three scenarios	97
6.9	Integration of solar	97
6.10	Radiation level in Abu Dhabi.....	98
6.11	Electricity generation-steam turbines.....	99
6.11.1	Results.....	100
6.12	Solar-steam for EOR.....	100
6.12.1	Results.....	102
6.13	System challenges.....	103
6.14	Summary of results	105
6.15	Conclusion	106
	References.....	107

List of Figures

Figure 1 Oil reservoir.....	3
Figure 2 USOC operations.....	7
Figure 3 Wellhead	8
Figure 4 Manifold gathering	8
Figure 5 Oil-gas separator	9
Figure 6 Gas compression.....	9
Figure 7 Storage.....	10
Figure 8 Drilling rig.....	13
Figure 9 Christmas tree.....	14
Figure 10 Rod pump	15
Figure 11 GHG effect	19
Figure 12 CO ₂ history and projection	20
Figure 13 Typical CO ₂ by source	32
Figure 14 CO ₂ distribution	33
Figure 15 Use of renewable energy 1949-2010	34
Figure 16 Distribution by sector	35
Figure 17 Distribution by source	35
Figure 18 Hydropower.....	36
Figure 19 Geothermal energy	37
Figure 20 Ocean energy	38
Figure 21 Wind turbine.....	39
Figure 22 Renewables technical potential	40

Figure 23 PV global capacity	41
Figure 24 CSP thermal power global capacity.....	43
Figure 25 Solar water heaters capacity	43
Figure 26 Crystalline silicon PV cells.....	49
Figure 27 Amorphous cell	49
Figure 28 CSP Parabolic trough.....	50
Figure 29 CSP tower.....	50
Figure 30 intensity vs. wavelength	52
Figure 31 Effective radiations.....	53
Figure 32 World's solar energy map	54
Figure 33 LCOE USD/MWh	58
Figure 34 LCOE sensitivity analysis	59
Figure 35 PV stand-alone.....	69
Figure 36 Soar for telecommunications.....	70
Figure 37 Solar RTU	71
Figure 38 Solar cathodic protection	71
Figure 39 Solar EOR.....	72
Figure 40 Bright source installation at Chevron, Coalinga.....	74
Figure 41 Decision flow chart.....	77
Figure 42 Decision process.....	78
Figure 43 Capital cost for different CSP technologies.....	84
Figure 44 O&M Cost	85
Figure 45 CSP world's best locations.....	86
Figure 46 Useful hourly radiations AD (Wh/m ²).....	99

Figure 47 Solar-steam electricity generation	100
Figure 48 CSP glasshouse.....	101
Figure 49 Solar storage supply.....	101

List of Tables

Table 1 Drilling rig components	12
Table 2 Type of crude oil and CO ₂ emissions.....	31
Table 3 PV global capacity GW 2012	42
Table 4 CSP solar thermal capacity 2012	42
Table 5 Solar energy technical potential and energy demand	51
Table 6 Economic analysis inputs.....	56
Table 7 Solar energy cost.....	60
Table 8 Solar energy challenges	66
Table 9 Solar in USOSC	69
Table 10 Options matrix	76
Table 11 possible options meeting selection criteria	79
Table 12 CSP vs. large scale PV	81
Table 13 Types of CSP	83
Table 14 Number of leaking sources	88
Table 15 Assumed sources of GHG.....	89
Table 16 Scenario one emission factors and GHG quantities.....	91
Table 17 Emission factors for gas and diesel combustion	92
Table 18 Scenario two GHG calculations.....	94
Table 19 Emissions factors for equipment operated by gas and diesel.....	95
Table 20 Emissions factors for land transportation based on fuel combustion.....	95
Table 21 Emission factor for storage tanks.....	96
Table 22 Scenario three GHG emissions	96

Table 23 CSP system specifications	98
Table 24 Average useful solar energy/month	98
Table 25 Reduction in gas combustion and saved CO ₂	102
Table 26 Financial advantages	103
Table 28 Summary of results	105

Introduction

Oil and Gas industries use different types of energy sources to run the daily operations, the type of used energy depends on the production process features. For example, natural gas is converted into heat, electricity and mechanical energy and electricity which is the most quantitatively significant among these applications, electrical energy drives pumps, fans and compressors in addition to providing power to control systems, communication equipment and lighting. Generating power to run the oil operation usually come from conventional sources, however due to the high prices of oil- as main source of generating energy- and due to the negative impacts of burning fossil fuel on the environment, the need to find alternative clean sources of energy became essential

Renewable sources can be good alternative to produce power for oil and gas industry and substitute conventional energy in certain areas or can be integrated with conventional sources in other more demanding area. However, renewable energy sources have technical implications that must be analyzed and compared with the industrial plant needs. The first step is analyzing the energy needs versus production and sustainability requirements and this includes qualifying and quantifying the renewable energy sources taking into consideration the future increase in demand. In addition to technical assessment, the renewable energy needs to be commercially competitive to be considered as alternative source of energy

1 Survey of crude oil operations

1.1 Crude oil and natural gas

1.1.1 Crude Oil

Crude oil contains more than 200 different organic compounds, mainly hydrocarbons. The difference in mixture composition gives different specific gravity and density which means different types of crude oil. This difference is measured by American petroleum institute (API) gravity number which measures the specific gravity and/or density, high API number means less density (lighter, thinner) crude oil and low API number or degree means higher density (heavier, thicker) crude oil.

The API numbers (density, gravity) starts from 7 up to 52 equivalent to density values from 975 kg.m^{-3} and 750 kg.m^{-3} respectively, however, majority of the API numbers range from 20 to 45. For example, a crude oil with API less than 35 is considered as light crude which means it contains shorter molecules and less percentage of the high commercial value products like high octane gasoline, similarly, oil with API more than 35 will contain longer and bigger molecules which need more processing to get high octane gasoline.

1.1.2 Natural gas

Known commercial natural gas is mainly methane, but the extracted gas will include other components with it depending on the type of well it is been found at, however, even if the well includes gas and oil, the gas might contain other hydrocarbons after separation (e.g. C_2H_6 , C_3H_8 , C_4H_{10} , C_5H_{12} and C_5H_{12}). The untreated natural gas will contain vapors, H_2S , CO_2 , H_2 and contaminations, the natural gas production process includes separation of natural gas from all other compounds whether liquid or gas

1.1.3 Condensates

The removal of hydrocarbons associated with natural gas gives 'natural gas liquids' (NGL). NGL products are ethane, butane, iso-butane, propane and natural gasoline which have many applications in oil and petrochemical industries; they can be used in enhanced oil recovery or used as energy source

1.1.4 The reservoir

The reservoir is the place where the pool of hydrocarbons exists inside a structure of porous rocks such as sandstone or washed out limestone ⁽¹⁾. See Figure 1

The porous rocks will be covered by non-porous layers (i.e. salt, shale) to avoid leaking and create oil reservoir. The structure of the reservoir (folded rock) will allow the contents to move to the surface using different techniques including natural pressure inside the reservoir or using lifting devices

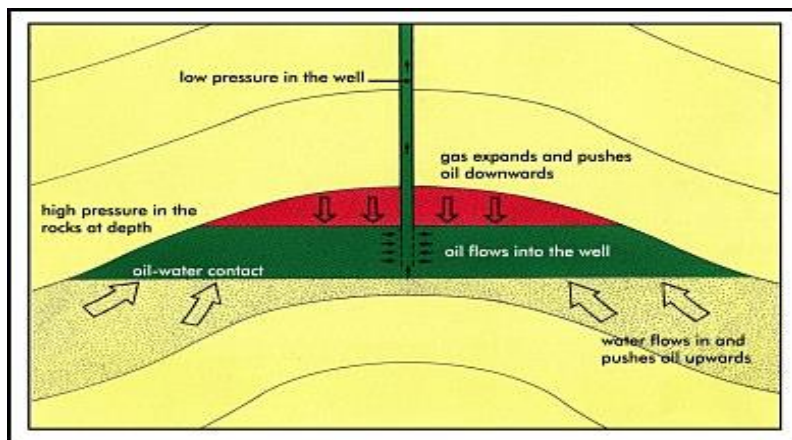

Figure 1 Oil reservoir (Source: *Oil production handbook, edition 2, ABB oil and gas 2009*)

1.2 USOSC operations

1.2.1 Background

Different countries produce oil with different capacities and technologies; production goes from as little as 150 barrels a day in some private wells to 5000 barrel a day in large wells. The depth of the well and processing technologies vary from one location to another, but production processes have the same principles, the oil production processes include three main stages:

- 1- Upstream, also called the exploration and production (E&P)
- 2- Midstream
- 3- Downstream

The midstream includes the transportation and storage activities of crude oil, which is sometimes considered as part of the downstream operation. Downstream stage includes the refinery, marketing and distribution operations

The upstream refers to the operation of oil exploration, well drilling and other well operations needed to extract oil from the reservoir to up to the surface and separation of oil and gas operations. A typical upstream oil production process consists of the following main components:

- 1- Wellhead feeding the production and manifolds
- 2- Manifolds: also called gathering system in a distributed production system
- 3- Gas-oil separation plant (GOSP)

Although, only oil or gas wells exist, the extracted hydrocarbons will includes (most of the times) full spectrum of organic compounds as gas (e.g. CH_4 , C_4H_{10} , C_5H_{12} etc.) or crude oil condensate, other

unwanted products will also exist like sand, water and salts. The objective for GOSP is to convert the extracted streams to products that can go to market or further processing like oil, natural gas or condensates

The upstream oil supply chain (USOSC) network is depicted in Figure 2, which shows different levels of the production and transportation routes. Every level is highlighted with different color. Any petroleum oil location may have several number of oil reservoirs. Every reservoir normally has a number of production platforms distributed over the reservoir area. The first level represents production platforms (P), which are distributed over different locations in a given oil field. Every platform is composed of a set of unit operations (charismas tree valves, two phase separators, well test equipment, flaring system, etc.) that serve the oil extraction task. Auxiliary equipment also exist on the platform to aid the main equipment for the extraction task. Collectively, these equipment eventually will be sources for direct and indirect greenhouse gas (GHG) emissions. Therefore, evaluation of these nodes in terms of production targets, energy demand, CO₂ and other emissions are necessary to cope with the emission problems. Besides, this evaluation will help to evaluate different energy technologies to deliver clean energy at these nodes

After oil extraction, the crude has to be transported from different locations existing in the oil field. The transportation task is carried out through a pipeline network which has a configuration specific to a given oil field. Normally, a collection platform (CP) (e.g., in the case of offshore oil fields) acts as a manifold to collect crude from different production platforms and route the crude to another location by a larger pipeline. This is represented as a second level in the overall network. The CP's eventually transport the crude product to a central processing facility which may exists onshore (level 3).

In the given oil network, level 3 shows the separation task of the extracted product. The purpose of this step seeks volume reduction and separating the fossil crude into its constituents. Normally, the gas content is first separated from the oil and water (emulsion) by slug catchers and scrubber units at early stages. Then, the emulsion can be broken into water and oil in a series of unit operations (e.g., heater treatment, settling tanks). The produced water goes into pre-treatment operations (e.g., air flotation, hydro cyclone units) to reduce the oil content before sending it to wastewater treatment facilities. Wastewater treatment facilities will reduce the BOD, metals, and salt contents before a final discharge into the environment.

In level 3 and 4, the produced gas may go through dehydration and sweetening processes before sending it to final users. Compression stations may also exist if trunk lines link the processing facility with the final users. It is also possible for the oil products to be shipped by tankers to other destinations. It is worth pointing out at this stage that the number of processes and the auxiliary equipment is large. The GHG emissions from a given network will depend on the production scale and relatively on the network complexity. Therefore, this study used a systematic engineering approach to cope with the GHG emissions reduction and mitigation objectives while keeping the production targets

1.3 Main processes

1.3.1 Wellheads

The wellhead is defined by its name, it is the part mounted on the top of the oil well as seen in figure 3 or on the top of injection well injecting water or gas inside the formation to balance the pressure and improve productivity. After drilling the well and getting clear indications that it has enough quantities to make it commercially viable to proceed to extraction step, the well will undergo a completion process to facilitate the movement of oil from the bottom to the surface, the completion step includes casing to

strengthen the well hole, measuring and assessing the pressure and temperature inside the reservoir and taking other necessary measures to ensure good flow of oil or gas out of the well.

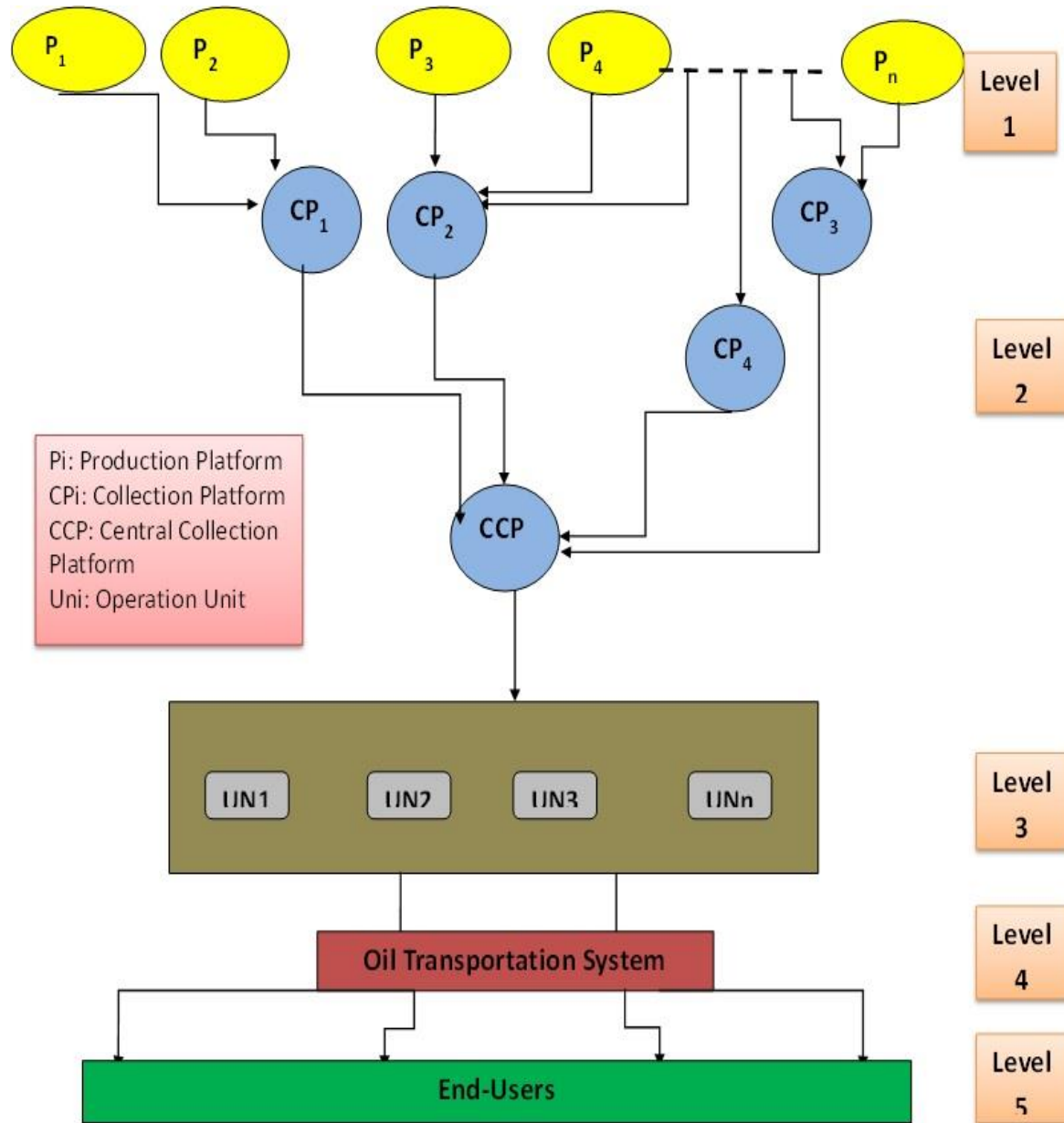

Figure 2 USOC operations

1.3.2 Manifolds gathering

All well streams will be directed to a main production facility through collection pipelines and manifolds systems, the objectives of the pipelines is to create a setup of production “well sets” to help in production planning and ensure the best utilization of the reservoir in different production levels.

In gas gathering, a flow metering devices are usually used to meter each line into the manifold as seen in figure 4. For multiphase and due to the cost of multiphase flow meters, a software flow rate calculator (which is based on well-known tested data) is usually used to measure the flow rate



Figure 3 Wellhead



Figure 4 Manifold gathering

(Source: Oil production handbook, edition 2, ABB oil and gas 2009)

1.3.3 Separation

If the well contains only gas, then it can be taken directly to production or compression (if needed), however, most wells usually contain a combination of oil, gas and water which need to be separated before further processing . There is number of different technologies for prodction separation using different designs of gravity separator as een figure 5, but they all have the same principle of separation. The idea of gravity separation is based on differnces in gravity, when the well flow enters the separator which is horzinta vessel with typical retention period of (5-7) minutes, the gas will move up, water will settling at the bottom of the vessle and oil will be in the middle

Another important parameter in separation process is the pressure which is reduced sometimes to control the separation of volatile components, but it is extremely important to avoid sudden drop in pressure to avoid flash vaporization which can lead to instability and safety hazards ^{(1) (3)}

1.3.4 Gas compression

If the gas is coming from a wellhead that contains only natural gas, it will have enough pressure to go directly to the pipelines. The gas coming out of separation system will have less pressure and therefore, it needs to be compressed to transport it, the compression turbines are fed by some amount of the gas being compressed. The turbine operates a centrifugal compressor which has a fan that compresses and pumps the gas through the pipeline, some compression systems use electrical motors to operate the centrifugal compressor and in this case no gas will be used. The compression system includes other equipment such as scrubbers (for liquid droplets removal), heat exchangers and lube oil treatment. See Figure 6



Figure 5 Oil-gas separator



Figure 6 Gas compression

(Source: Oil production handbook, edition 2, ABB oil and gas 2009)

1.3.5 Storage

Gas is not usually stored in local tanks inside the facilities, but oil is stored in local storage tanks before being sent to shipping vessels, shuttle tanker takes oil to a bigger storage facilities or direct to shipping

Large operations will usually have “tank farm” as seen in figure 7 to store different grades of oil in order to balance any change in demand or re-scheduling of transportation. The tank farm will include metering systems to measure the oil and gas transportation from the production installations



Figure 7 Storage

(Source: Oil production handbook, edition 2, ABB oil and gas 2009)

1.3.6 Oil transport

Oil or gas is transported inside the operation site using network of pipes and depending on the distance of transportation, pumping station might be needed to maintain good level of pressure for oil flow

1.3.7 Reservoir and Wellheads

This section gives more details about the reservoir and the wellhead operations. The wells are divided into three main types:

- 1- Oil wells with associated gas
- 2- Natural gas wells that have pure gas or mainly gas with small amount of oil
- 3- Condensate wells that have natural gas and liquid condensate; the condensate is a liquid hydrocarbon blend, that is usually separated from gas at the wellhead or in the next processes

The three types have almost the same completion procedures with small technical differences, many technical factors need to be considered when handling each type of the above wells. For example in natural gas wells, a lifting device is not needed as gas will go up to surface because its lighter than air, the case is different in oil wells where lifting device is essential specially that pressure in the reservoir will be less with years

1.3.8 Exploration and Drilling

Upon completion of the (3D) seismic and making sure that well has enough hydrocarbons, the decision of well drilling will be taken and drilling rig will be assembled on the well location. A typical drilling rig similar to the one in figure 8 will consist of the components listed in table 1

1.3.9 The Well

Making the well ready to start operation is called well completion and where the final setup of the equipment is installed taking into consideration the characteristics of the well and the product type to be extracted, the well completion stage includes the following steps:

- 1- Well casing installation
- 2- Wellhead installation
- 3- lifting equipment installation (if needed)

Table 1 Drilling rig components

No.	Item	No.	Item	No.	Item	No.	Item
1	Mud pits	8	Stand-pipe	15	Monkey board	22	Bell- nipple
2	Shale- shaker	9	Pressure hose	16	Pipe stand	23	Blowout preventer- annular
3	Suction line	10	Goose-neck	17	Pipe-rack	24	Blowout preventer
4	Mud pump	11	Travel- block	18	Swivel	25	Drilling-string
5	Power Equipment	12	Drill-line	19	Kelly drive	26	Drilling-bit
6	Vibration nozzle	13	Crown -block	20	Rotary table	27	Casing -head
7	Draw-works	14	Derrick	21	Drilling-floor	28	Flow-line

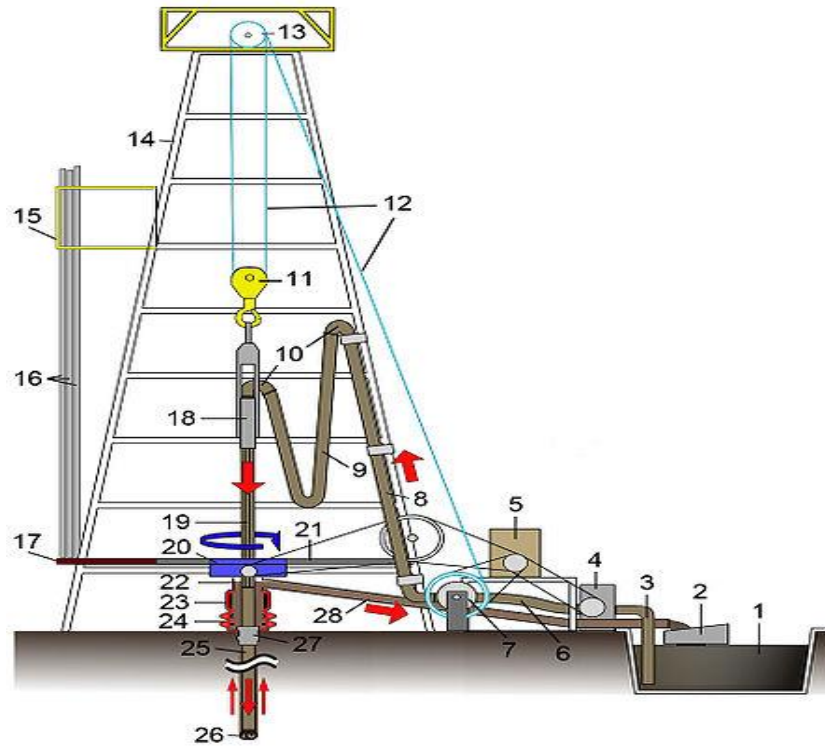

Figure 8 Drilling rig
(Source Wikipedia,)

1.3.9.1 Well Casing

The purpose of well casing is to strengthen the sides of the well hole, avoid leakage through the movement of oil or gas to the surface of the well. The well casing is done by installing metal tubes on the sides of the drilled hole, the characteristics of the well surface will define the type of casing to be done specially the diameter of the well hole in addition to the pressures and temperatures measured in the well

(2)

1.3.9.2 Wellhead

The set of equipment installed at the top of well to control and monitor the extraction of the targeted products from the formation is called wellhead, another purpose for the well head is to prevent leakage from the well, it has safety role in case of high pressure. However, in order to avoid blowouts, it should be

designed to withstand high pressure (up to 140 MPa). A typical wellhead have three major pieces; casing-head, tubing- head, and Christmas tree as seen in figure 9



Figure 9 Christmas tree

(Source of pictures: Vetco international)

1.3.9.3 Injection Wells

In addition to oil wells, it is common in oil and gas industry to drill “injection well” to inject water, steam or gas into the formation for enhanced oil recovery purposes to keep good level of pressure inside the reservoir and ensure smooth flow of oil or gas to the surface

1.3.10 Artificial lift

In the cases when the pressure inside the well is not good enough to move the oil or gas to the surface or when the injected water or gas can’t keep the pressure levels enough to have upward flow of oil or gas, then the need for artificial lift arise, typical lifting methods include:

1.3.10.1 Rod pumps

The most widely used artificial lift system is the sucker rod pump which has other names like “donkey pump” or beam pump. The pump consists of motor, gearbox, reciprocating beam, polished rod which pass into tubing through stuffing box where the sucking will go down into the well while connected to a plunger with a valve, see figure10

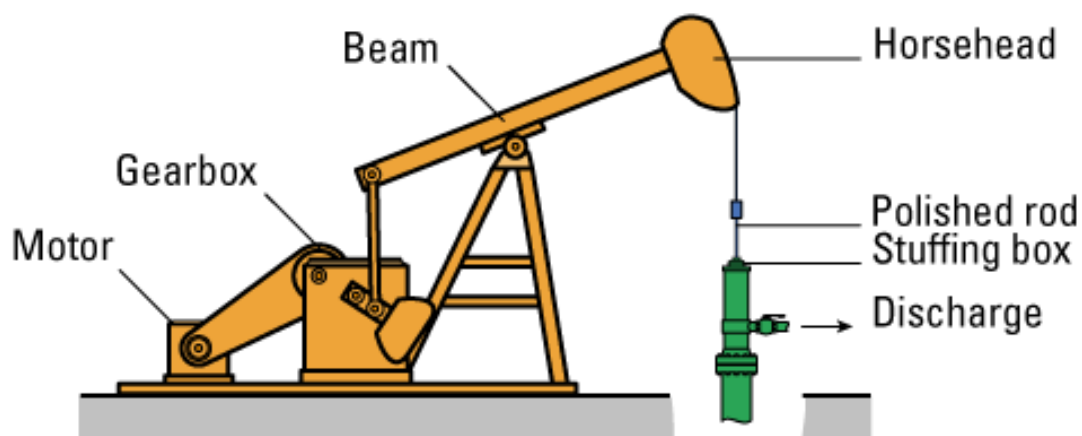

Figure 10 Rod pump

(Source: Oil production handbook, edition2 ABB oil and gas 2009)

With every stroke in the downward direction, the plunger will sink inside the oil reservoir allowing oil to flow inside and when the stroke direction is reversed in the upward direction, oil will be lifted by the plunger and then leave the system through the well head discharge

1.3.10.2 Down-hole pumps

In some cases, the pumping system will be inserted inside the well, an example of this is the electrical submersed pump (ESP) where multiphase pumps (progressive or centrifugal) connected by electrical power source through cables will be inserted into the well to pump the oil to the surface

1.3.10.3 Gas lift

When gas is injected into the oil reservoir, the overall specific gravity will be reduced and therefore, the movement upward will be facilitated and with the suitable amount of gas injected, the oil will start moving upward

1.3.10.4 Plunger lift

This method is used when the pressure is low in a gas well containing higher ratio of condensate, where the condensate will begin to collect down hole and block the gas movement, the plunger have open/close valve mechanism so when it is inserted inside the well with open valve, the oil, gas and condensate will get through the plunger moving to the bottom and when the valve is closed, an amount of oil, gas and condensate mixture will be on top allowing gas pressure to accumulate in the bottom. Repeating this process number of times will increase the gas pressure under the plunger and move it upward having the liquid on top and once it reaches the well head it will go out through the discharge opening

1.4 Energy in USOSC

1.4.1 Energy consumption sources

Upstream oil operations are energy intensive; the main sources of energy come from gas, diesel and electricity supplied from the external network or onsite production facility supported by emergency generators and uninterruptable power systems. The energy consumption in oil operations can be summarized into the following groups:

- Hydrocarbon extraction equipment (drilling rig)
- Water injection pumps
- Gas compressors
- Heating the output stream for separation of the oil, gas and water
- Generating steam for enhanced oil recovery

- Re-injection of gas for enhanced oil recovery
- Compressors and pumps for oil transportation
- Electricity generation turbines for oil processing and onsite residences

1.4.2 **Energy return on energy invested (EROEI)**

Energy return on energy investment (EROEI) is very important term in the oil and gas industry that is used to assess the economics of the oil and gas industry and help governments and industry planners to devise the suitable energy strategies for the future

EROEI is defined as the ratio of energy generated to the energy invested in the oil and gas production processes; EROEI gives an indication if the energy production process is gainer or loser. The energy investment includes the financial and environmental cost elements.

EROEI values in oil and gas industry are in continuous decline which motivated researchers, energy companies and governments to look for alternative sources of energy to minimize the dependence on conventional sources

2 Greenhouse Gas Emissions

The Greenhouse gases (GHG) refers to the gases in the atmosphere that absorb the long infrared radiations and send it back to the earth's surface causing the Greenhouse gas effect, GHG's have very negative impact on the environment and climate change

2.1 Investigated gases

An investigation for the greenhouse gas emissions (GHG) in USOSC is carried out in this study to identify the sources and effects of the followings gases:

- 1- Carbon dioxide (CO₂)
- 2- Methane (CH₄)
- 3- Nitrogen oxides (NO_x): NO and NO₂
- 4- Nitrous oxide (N₂O)
- 5- Volatile organic compounds (VOC's)

Carbon dioxide and Methane are the main emissions considered in the USOSC operations, number of technologies are used to reduce and capture the emissions of these two gases as they are a major source for air pollution and climate change, but this doesn't mean that the other emissions are not important as they are also considered as source for air pollution

2.2 Greenhouse gas effect

The surface of the earth obtain the energy from two sources: the sun and the atmosphere, the surface temperature will be reduced by around 33°C without the energy of the atmosphere, the greenhouse gases don't absorb shortwave infrared radiations, but absorb the long waves and, therefore atmosphere stores energy

Solar radiations passing through the atmosphere will be converted to heat once they reach the earth, some radiations will be reflected by earth's surface back to space, some of these radiations will pass through the space and some will be reflected back to earth's surface by the greenhouse gas as seen in figure 11

Many countries in the world have adopted policies and regulations to control CO₂ emissions due to the serious consequences of CO₂ on the environment, health and climate change. Oil production and consumption are considered as major sources for CO₂ emissions. Detailed list for the CO₂ emissions from oil consumption in most of the world countries can be found at EIA website [EIA website](#) ⁽³⁾

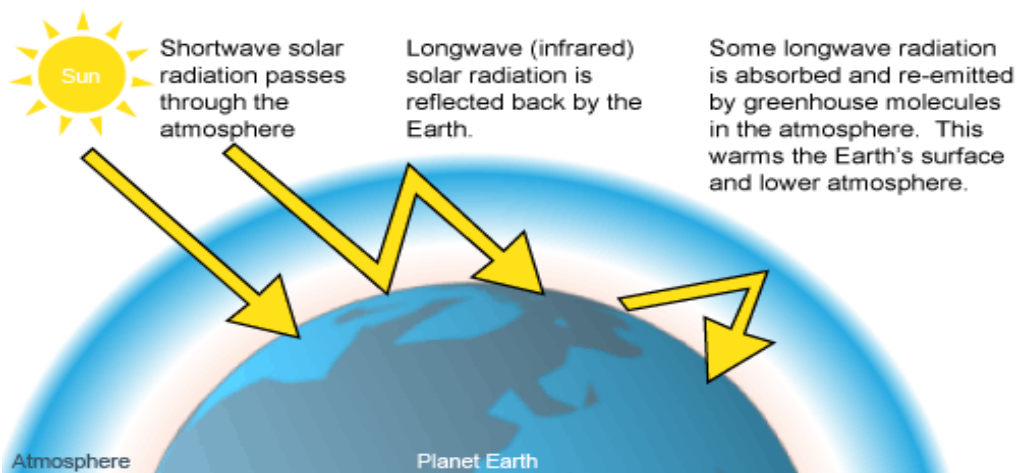

Figure 11 GHG effect

(Source cool the world website <http://www.cooltheworld.com>)

2.3 Carbon dioxide emission projection

Due to the continuous increase in industrial activities and the increasing use of fossil fuel based energy, the emitted CO₂ quantities are expected to increase every year unless a breakthrough in clean energy is achieved, the amounts of CO₂ emissions have increased significantly in the last two decades as seen in figure 12 which also shows a projection of CO₂ emissions in billion metric tons till the year 2040 for

three types of fossil fuel based energy sources ⁽⁵⁾, more details about yearly projection can be found in US energy information administration website [EIA website](#)

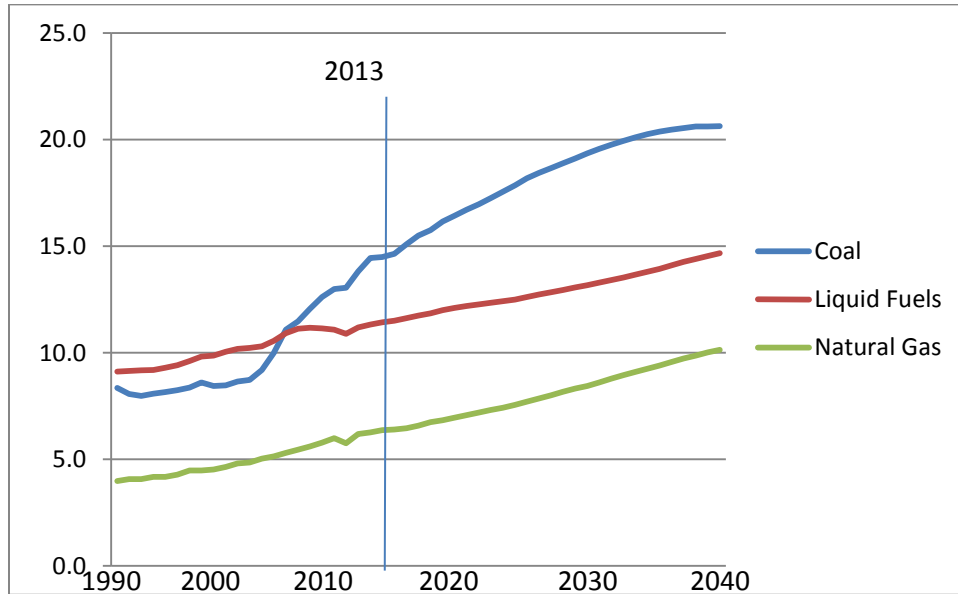

Figure 12 CO₂ history and projection (billion metric tons)

(Data Source: EIA report 2011)

2.4 GHG in USOSC

Generally, through the life cycle of oil from exploration to transportation after refinery, which can be referred to as “well-to-wheels” or WTW, the CO₂ emissions generated (as the major GHG gas) in USOSC is (20-30) % of the total emissions ⁽⁸⁾

2.4.1 Main sources

The GHG sources in USOSC can be classified into five main groups: ^{(4) (5)}

1. Combustion devices
 - a. Stationary devices (e.g. burners, flares)
 - b. Mobile devices (e.g. trucks, ships)

2. Point Sources: (e.g. stack, venting)
3. Non-Point Sources (e.g. Methane-fugitive emissions, water treatment processes, waste handling)
4. Non-routine activities: (e.g. unplanned maintenance, urgent work due to emergency needs)
5. Indirect emissions: this includes activities not directly happening inside the facilities (e.g. outsources electricity)

Each stage in the USOSC includes certain activities/group of activities that can be considered as similar source of GHG. For example, the exploration and well development phases can be divided into sub-groups of activities, the different activities in the same sub- groups are considered as one source of GHG emissions and will have common plan or strategy to reduce GHG emissions. The exploration and well development phases can be divided into the following sub-groups:

- a) Well pad clearing and road construction
- b) Setup the rig, drilling and rigging down
- c) Completing the well and final testing

In the production phase, the emissions sub groups are divided into the followings:

- a) Compressor engines
- b) Pumps for rigging
- c) Leaks from pipeline
- d) Visits to well site
- e) Wastewater Biological oxygen demand (BOD)

As will be seen in the case study section, carbon dioxide (CO₂) is the main gas among all the GHG in USOSC. The main sources for CO₂ emissions can be classified into two groups:

- 1- Fuel combustion for vehicles, turbines and engines operations
- 2- Fugitive emissions from different operations

CO₂ emissions from combustion devices are almost the same regardless of the type of combustion equipment as the CO₂ emission factor is almost the same for most of the combustion devices.

Most of the methane emissions are fugitive emission coming from operation devices, the main sources of methane are the followings:

- 1- Separators
- 2- Dehydrators
- 3- Combustion engines
- 4- Pipelines pumps
- 5- Power equipment

The emission factors for methane varies from one combustion device to another and in some cases it reaches up to 15 % of the total GHG emissions from combustion devices. A more detailed identification of the greenhouse emission from each process in USOSC is investigated below

2.4.2 Exploration phase

The GHG's in this phase are coming mainly from operations related to generating seismic waves using different technique to decide the viability (quantity based) of oil/gas before drilling the well; like making holes in the ground using explosives in certain distance under the earth surface or using special trucks to put vibration pads on a hard solid surface like constructed roads to generate seismic waves

2.4.3 Well development phase

During well development step; combustion devices fed by natural gas obtained from the process itself or out-sourced diesel are the main sources for GHG emissions specially carbon dioxide (CO₂). These devices include trucks, beam jack engine, construction devices and heaters. The activities under well development phase can be categorized as the followings:

2.4.3.1 Well pad area

Based on the size of well- pad; the number and type of diesel-operated trucks required to clear the well pad location will be determined. Using multiple rig pads can help in the reduction of the greenhouse emissions as the number of trucks, work hours, number of truck trips and travelled distance will be reduced which will also help in the reduction of the vegetation disturbance

Possible GHG emission: CO₂

Other effects: vegetation disturbance

2.4.3.2 Roads construction

Roads construction is considered as source of GHG emissions as a result of fuel combustion (mainly diesel) in vehicles and equipment constructing the roads, and the use of surfactants to prevent dust during the construction process.

Possible GHG emissions: CO₂

Other effects: vegetation disturbance

2.4.3.3 Rigging-up and drilling

Energy obtained by fuel combustion is needed to setup the rig and start drilling which is a source of greenhouse emissions, the rig includes large number of equipment like desanders, de-salters, vacuum degasser (for gas removal), diesel engines, and the derrick (pumping rig), the amount of GHG emissions in this stage depends on the amount of power needed for operations which depends on many factors like the depth of drilling, direction of drilling, size of the well hole, drill size and power.

Another source for GHG in this stage is the fugitive emissions generated from equipment leakage, if the rig is powered by electricity, then indirect generation of GHG emissions will also be associated with this stage of operation

Possible GHG emissions: CO₂

2.4.3.4 Drilling fluids

During drilling operations, it is very important to cool the drill and drilling fluids play this role in addition to lubrication of the drill, removal of fragmented rocks and pressure balance in the formation. Drilling fluids come into number of forms; it might be gas-based, foam-based or liquid fluids, GHG emissions will be generated if gas-based fluid is used or they will be generated from volatilization if foam or liquid based fluids are used.

Methane (CH_4) can be generated from flaring or venting of drilling fluid vapors, however, according to the Canadian Association of Petroleum Producers (CAPP)⁽⁶⁾, the amount of GHG emissions from drilling fluid is insignificant compared to emissions generated from the rest of drilling operations

GHG emissions: CO_2 and CH_4

2.4.4 Casing

The purpose of casing is to strengthen the sides of the well hole and to avoid leakage through the movement of oil or gas to the surface of the well. The well casing is done by installing metal tubes on the sides of the drilled hole, the well-surface characteristics will define the required casing specifications specially the diameter of the well hole in addition to the pressures and temperatures measured in the well, the possible GHG emissions from casing step is insignificant with possible methane fugitive emission leaks

GHG emissions: insignificant (possible CH_4)

2.4.4.1 Tubing installation

The tubing stage could require pumps, separation equipment, pipeline connector or storage tank. The equipment installation will be powered by fuel combustion which will generate GHG emissions

GHG Emissions: fugitive CH_4 emissions and CO_2

2.4.5 **Completing the well and final testing**

Number of tests can be done to ensure that the reservoir is good enough to start production, like coring, logging a wire-line or drill stem testing. In these tests carbon dioxide and methane might be emitted

GHG emissions: CO₂ and CH₄

2.4.6 **Fracturing**

If the oil or gas flow to the surface is found be difficult due to tight pore space, then fracturing processes might be needed to solve the situation by injecting water (typically water, but other substances can be used) with high pressure down ward to blow up rocks and open space for the oil and/or gas to flow smoothly. The injection machines are usually operated by diesel and will thus generate CO₂ emissions

GHG emissions: fugitive methane (CH₄) emissions and carbon dioxide (CO₂)

2.4.7 **Flaring**

When the gas well becomes over pressurized, burning some of the extra waste gas or flammable gas becomes necessary to reduce the well pressure and maintain it within normal levels, this process is called flaring, and this will generate carbon dioxide and methane. Flaring might also be done for other reasons, like burning extra gas quantities exceeding the users need or burning the unburned gas from production processes or during shutdown processes

GHG Emissions: Water vapors, CO₂ and CH₄

2.4.8 **Venting**

Releasing gas to the atmosphere is called venting, sometimes venting is better option get rid of the unwanted gases like the case when the gas contains high percentage of inerts, venting is done in many processes in the oil operations, including the followings:

- 1- Completion of the well

- 2- Unit operation maintenance
- 3- Maintenance for transportation pipelines
- 4- Storage facility operations and maintenance

GHG Emissions: CO₂ and CH₄

2.4.9 Compressor engines

If the gas pressure in the well is not high enough to smoothly move the hydrocarbons from the reservoir upward, then compressor engines will be needed to increase the gas pressure in the pipes to achieve smooth flow of hydrocarbons to the well head. The smaller the engine is, the smaller the emissions generated but with higher emission rates. These engines usually use turbine or reciprocating engine, the turbine engines generate less over all GHG emissions than reciprocating engines, however, the methane (CH₄) emissions is less in reciprocating engines, carbon dioxide will come from the fuel combustion

GHG emissions: CO₂ and CH₄

2.4.10 Primary production phase

One of the main sources of emissions in this phase is coming from compression operations which have similar function to the compressor engines in the well completion, in case of multiple pad production, a central compression facility will be providing energy to the multiple locations. The central facility is usually powered by fuel combustion which can be either diesel or natural gas

GHG emissions: CO₂ and CH₄

2.4.11 Secondary and tertiary recovery

Usually, primary recovery will extract one quarter of the possible quantity; therefore a secondary and tertiary recovery will be needed, the process is based on re-injecting water (other products can be injected including steam, CO₂ or surfactants) to enhance the oil/gas movement. Large amount of energy is needed

to run the secondary and tertiary recovery, the type of GHG emission depends on the type of substance to be re-injected

GHG emissions: CO₂ if it is used as injection substance and from combustion devices and fugitive CH₄ if gas is re-injected

2.4.12 Well site visits

The trucks used to conduct scheduled visits for different purposes, like preventive maintenance or production monitoring are source of greenhouse emission due to combustion of fuel in the used trucks

GHG emissions: mainly CO₂

2.4.13 Separator and dehydrator

To avoid pressure build up in the separator and dehydrator, some flaring might be necessary, this flaring is a source of GHG emissions; the separator and dehydrator emissions can be classified as the followings:

2.4.13.1 Separator: Two types of separation processes generate GHG emissions, they are:

- a. Crude oil separation: the gas components and other solids remaining after oil extraction should be separated and taken away before transportation for further processing

GHG emissions: fugitive CH₄ and CO₂

- b. Natural gas conditioning: if gas is not pure enough after extraction, impurities associated with natural gas including hydrogen sulfide and nitrogen must be removed in a conditioning process by dehydration or sweetening, Sweetening using amine treatment removes hydrogen sulfide and carbon dioxide from the gas then sulfur can be recovered in special recovery process

GHG emissions: CO₂

2.4.13.2 Dehydrator

The dehydration process removes water from the oil; the process releases volatile organic compounds and will also generate methane emissions from pipe leakage

GHG emissions: CO₂ and CH₄

2.4.14 **Wastewater disposal**

Due to the wastewater contaminants, carbon dioxide (CO₂) and methane (CH₄) might result from aerobic respiration and anaerobic fermentation

GHG emissions: CO₂, CH₄ and VOC's

2.4.15 **Other facilities**

Other facilities required in USOSC operations might be possible source for greenhouse emissions, like amine facility and vaporization ponds

GHG emissions: CO₂, CH₄, and other GHG's

2.4.16 **Leaks**

Leaks can happen in all operations, like leaks from casing, valves, and pipes or during scheduled maintenance and equipment replacement. However, the major source of leaks in USOSC comes from reciprocating compressor, centrifugal compressors, valves and pump seals

GHG emissions: CO₂, CH₄ and VOC's

2.4.17 **Accidental release**

In most of the times, production goes without major accidents, however, in case a blowout happens at any step in the production process, it can cause big release of gases and greenhouse emissions and will continue to do so till damage is recovered and control measures is taken again

GHG emissions: CH₄, CO₂ and other GHG's

2.5 GHG assessment/quantification

The task to estimate the GHG emissions in USOSC is very challenging due to the limited available data and the high uncertainty in the calculation methodologies found in literature. The initial approach of this study was to identify the list of equipment in each process and quantify the amount of GHG emissions from each equipment, but due to the complexity of this task and the lack of accurate data available to public (these data are considered propriety information for the oil companies and equipment OEM), the quantification approach used in this study (as will be seen in the case study section) used analytical assumptions and three calculation scenarios to check the variance in results in order to evaluate the GHG emission in USOSC, for example; the calculation of CO₂ as major gas among the GHG's is based on fuel combustion from different devices using the emission factor for each device

This section investigates the factors behind the uncertainty in GHG calculations and an example is given to illustrate the variance in GHG calculation results

2.5.1 Un-certainty

The methodology in GHG calculations affects the accuracy of results, the variance in results can reach up to (30) % which indicates the level of un-certainty and complexity of the GHG estimate, the un-certainty and variation happen due to number of factors ⁽⁷⁾

2.5.1.1 Data availability and quality

Because of proprietary issues in oil industry, it is challenging to get accurate information for greenhouse emissions for certain crude oil type or process. In case of data availability, it must be verified and updated as greenhouse gas intensity changes with time due to technology ageing and improvements in production practices

A study by IHS CERA ⁽⁸⁾ addressed this challenge in a special report in 2011 that compared environmental data from different oil producing facilities in different countries and came to conclusion

that only 50% of the collected data have meaningful information that can be used to estimate GHG, however, significant variation was found in these estimates leading to high levels of un-certainty

One of the main reasons affecting the data quality is the data recording procedures for the frequency and amount of venting and flaring since the more often they happen, the higher the carbon intensity becomes which must be reflected in the calculation to give accurate results. In this study, it was found that Canada is one of the very few countries that measure and record the venting and flaring data and make these emissions data available to public

2.5.1.2 Emissions allocation

The calculations that looks into the whole process from well to wheels might use different approaches in attributing the emissions of a process to the output of this process based on products allocations, which gives variation in the GHG estimate results. For example, if calculations are based on considering that majority or all greenhouse emissions are referred to gasoline (considering that the other products are by-products of gasoline), the results will be different than considering the volume of the refined products as base for GHG emissions allocations, and both will give different results than calculations if the energy used in production is used as base of GHG calculations

2.5.1.3 Estimate boundaries

The calculation “boundaries” is another important reason for variance and uncertainty. For example, the generation of out-sourced electricity for USOSC operations and construction activities are considered as indirect or secondary sources of GHG emissions, if they are taken into consideration; the result will be different than setting the calculation boundaries for onsite oil related operations only

2.5.1.4 Estimate objectives

Some calculations are done to estimate the average emissions for the oil industry or for the country in general (for policy regulation purposes) while other calculations can be more focused on specific

operation to do detailed analysis of certain operation or type of crude oil which needs intensive efforts to obtain accurate data

2.5.2 Other factors

The production technologies, process flow, type of equipment and operating conditions strongly affect the calculations of GHG. However, some factors are common to all production technologies, the followings are example of these factors: ⁽⁹⁾

- Oil-water or gas-oil ratios used to calculate the re-injection requirements
- Venting and flaring needs: standard gas vs. recovered gas, venting sources control levels and ratio of flaring/venting quantities from crude oil versus quantities from gas sources
- Type of lifting used in secondary and tertiary recovery (e.g. water, steam or CO₂)
- The separation practices and the quantities of re-injection of water or gas

2.5.2.1 Type of crude oil effect

In addition to the above factors, the type of processed crude oil and country of production affect the estimate of GHG emissions (level of GHG's control measures differ from one country to another), table 2 shows the total CO₂ emissions (kg CO₂ per barrel produced) for different crude oil types produced in different countries in 2005 ⁽⁷⁾

Table 2 Type of crude oil and CO₂ emissions (kg CO₂ per barrel produced)

Crude Name	GHG in USOSC	Crude Name	GHG in USOSC
US Sunset	132	Mexico-Maya	46
US CYMRIC	115	Russia-REBCO	56
Nigeria- Light	86	Kuwait/Saudi EOCENE	34

2.5.3 Typical CO₂ distribution in USOSC

Although estimated quantities of CO₂ differs from one calculation method to another as discussed in the above sections, however, the CO₂ percentage distribution by source is found to be almost similar in most of the investigated sources, figure 17, shows typical CO₂ in USOSC (based on heavy oil production) .

As seen in the distribution, fuel combustion and venting activities are considered as the major sources of CO₂ emission while accidental releases and storage activities have the lowest share of CO₂ emissions

(7)(8)(10)

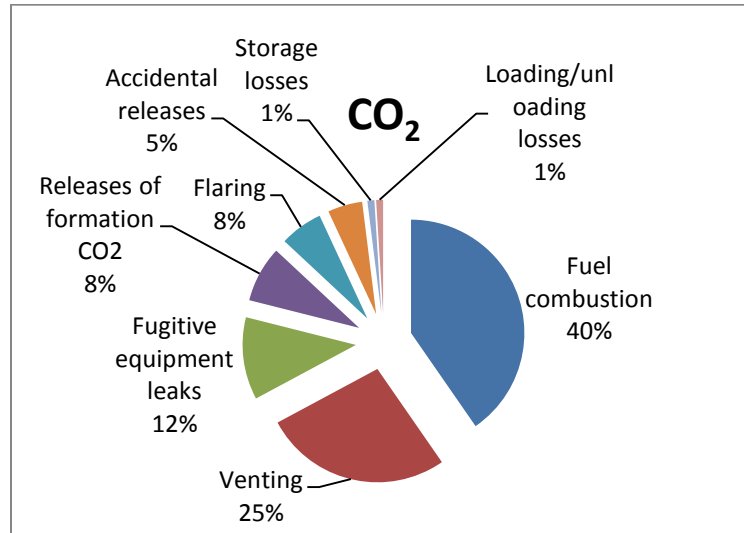

Figure 13 Typical CO₂ distribution by source

(Source of data ref. 7, 8 and 10)

2.5.4 Study example

IHS CERA ⁽⁸⁾ studied different cases and production facilities, the study reported big variations in the estimate of CO₂ emissions (1-25) kg CO₂e per barrel of produced for Saudi medium crude oil which indicates the complexity of having one model of GHG emissions estimate for different processes and

productions practices, however, the study reported almost similar distribution for the CO₂ generated in USOSC operations⁽⁹⁾ as shown in figure 14

2.5.5 Accurate estimate of GHG

The estimate of the total GHG emission in USOSC varies significantly from one facility to another due to the reasons discussed in the above sections. No single source can be used as a reference for accurate theoretical estimate of the GHG emissions

Many studies have investigated the GHG emissions and recommended improvements on the operation methods to reduce GHG emissions. In this study, we will be investigate the possibilities of integrating renewable energy with conventional sources feeding the USOSC operations with the required energy with the view to reduce GHG emissions and minimize the reliance on conventional sources.

In the next section, we will review the possible renewable technologies to be integrated

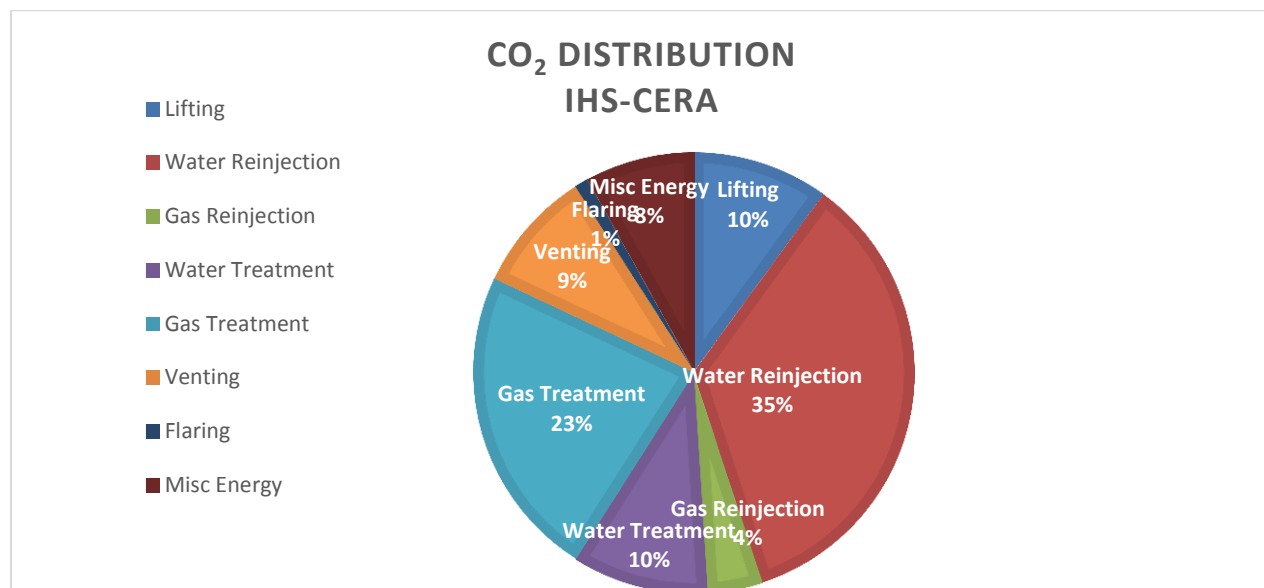

Figure 14 CO₂ distribution

(Source HIS- CERA 2011)

3 Renewable energy

Renewable energy is the energy obtained from natural replenished sources; like Sun, Wind, Ocean and Geothermal. The renewable energy have great potential, for example; the energy coming from the sun alone, either directly in the form of solar power or indirectly like wind or geothermal is enough to meet the energy needs of the whole world if can be utilized in effective way, also sun alone has enough energy to provide the earth by its energy for 1 billion years from today (based on current energy needs).Renewable energy sources include provides part of the global energy needs, according to the International Energy Agency (IEA) ⁽³⁾ renewable energy provided 16 % of the total energy consumed globally in 2012.

Some types of renewable energies are commercially used since more than 50 years like the hydro and geothermal and they are very competitive to conventional energy, while other sources of renewable energy like solar and wind started to become more competitive in the last decade and showed sharp rates of growth. This is due to technological improvements, high oil prices and the support of clean energy policies. Figure 15 shows the historical use for renewable energy in the last 60 years, figure 16 shows the 2012 distribution by source and figure 17 shows the distribution by sector ⁽¹¹⁾

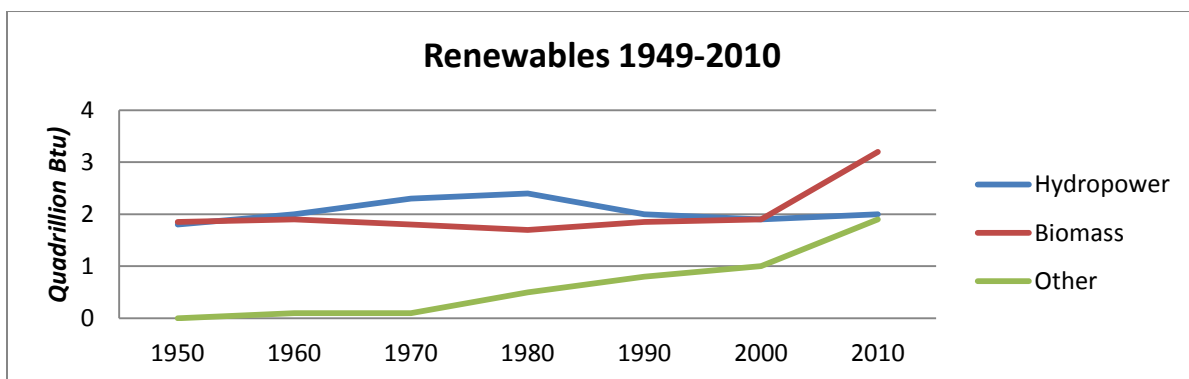

Figure 15 Use of renewable energy 1949-2010 (Quadrillion Btu)

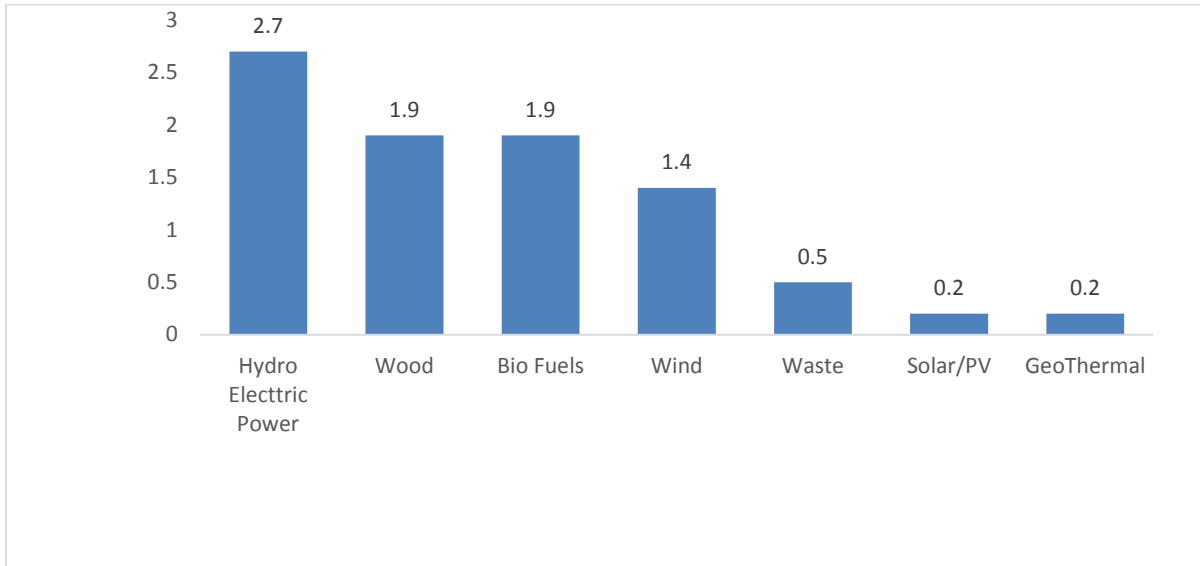

Figure 16 Distribution by sector (Quadrillion Btu)

(Source of data: EIA report, US energy information administration, monthly report Nov. 2013)

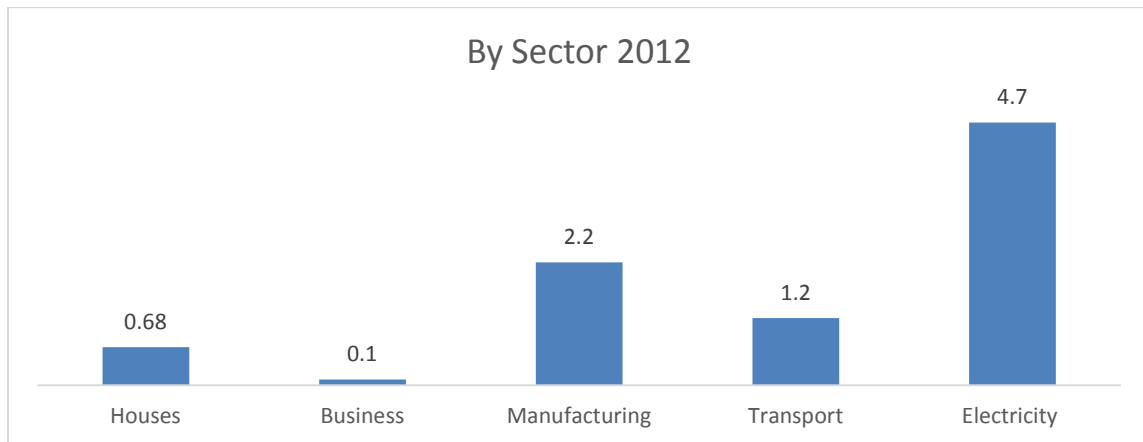

Figure 17 Distribution by source (Quadrillion Btu)

(Source of data: EIA report, US energy information administration, monthly report Nov. 2013)

3.1 Hydropower

Hydropower usually refers to the electricity generated using turbines driven by falling water either naturally from rivers or using water dams, see figure 18. Hydropower is the biggest source of electricity

generated from renewable sources, the current production capacity of hydropower facilities around the world is around 3000 terawatt.hours and it is expected to double in 2050 ⁽¹²⁾

In addition to cost, hydropower has two main advantages over the other renewable energy sources used to produce electricity like wind and solar; the large storage capacity and the ability to produce electricity in short time compared to wind and solar, however, hydropower has some negative impacts on environment and it affects the natural water resources distribution

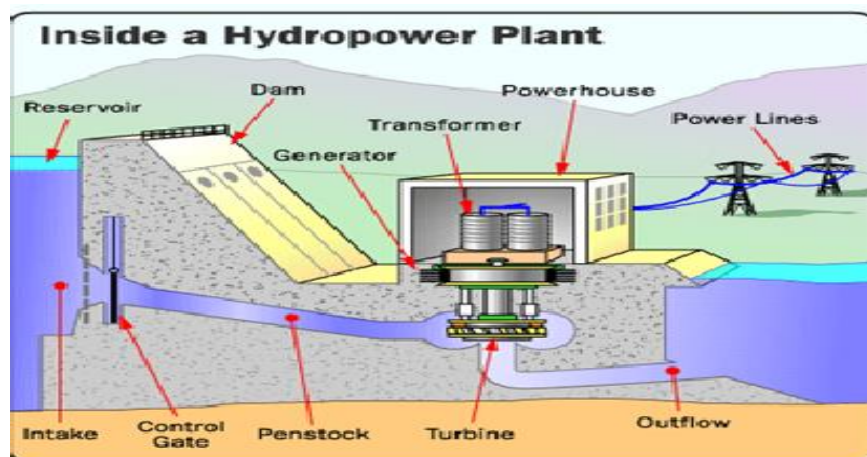

Figure 18 Hydropower

(Source: how stuff works website)

3.2 Biofuels

Biofuels, like bioethanol and biodiesel are fuels obtained from biomass; which is defined as a decomposed organic derived from plants or animals, like vegetables, wood and organic wastes. The conversion of biomass to biofuel can be done in three methods: chemical, thermal and biochemical and can produce fuel in solid, liquid or gas phase .The growth of biofuel energy production, both liquid and gaseous fuels, was very sharp in the last decade. The total global generation of biofuels in 2011 was

around 100 billion liters which is six times more than the production in year 2000 ⁽¹³⁾. Biofuels share in the global supply of energy needed for land transportation fuels was 3 % in 2011 and in Brazil alone; biofuels share was around one quarter of the total country fuel consumed in land transportation

Biofuels cost can be competitive to fossil fuel to some extent, however, the environmental consequences, like vegetation disturbance and deforestation and the need for more cost effective production processes, are major challenges to the growth of biofuels energy market

3.3 Geothermal energy

Geothermal energy is defined by its name as thermal energy obtained from the earth due to the difference in the temperature (heat contents) between the earth's core (temperature around 5000 °C) and the earth's surface which drives the heat from the core upward to the earth' surface as seen in figure 19

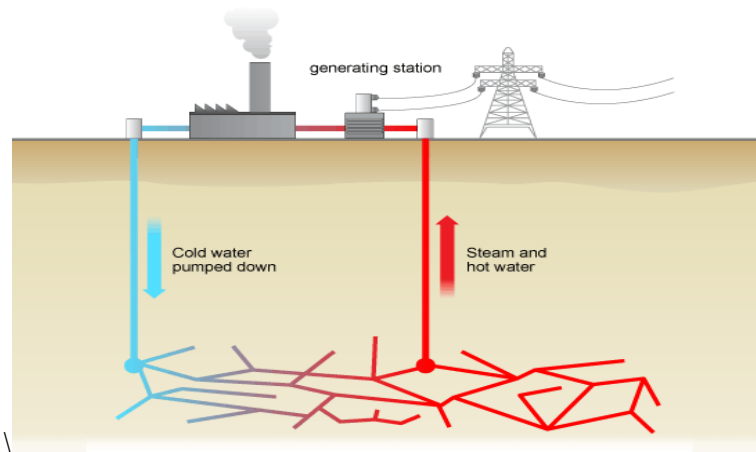

Figure 19 Geothermal energy (Source BBC website)

Geothermal energy is sustainable source of energy that is-theoretically- enough to meet the global demand of energy with no serious consequences on the environment and it is also a commercially

competitive source of energy specially for heating applications, however, geothermal energy has always been limited to certain geographical areas close to “tectonic plate boundaries”. The United States is the biggest producer of geothermal energy; the cost of electricity generated from geothermal energy has reduced significantly in the last 20 years and reached to less than ten US cents per KW in some production locations

3.4 Ocean energy

Ocean energy (marine energy) is a kinetic energy obtained by the movements of ocean’s water due to waves, tides or temperature gradient for example. The kinetic energy can be converted to electricity as seen in figure 20 to power residential homes or industrial facilities, the ocean’s energy is a developed source of energy with high potential of energy if can be utilized in cost effective way. The major challenge to Ocean energy is the availability and consistency; however, some locations in the world are excellent places to utilize the ocean’s energy like Scotland and northern Canada

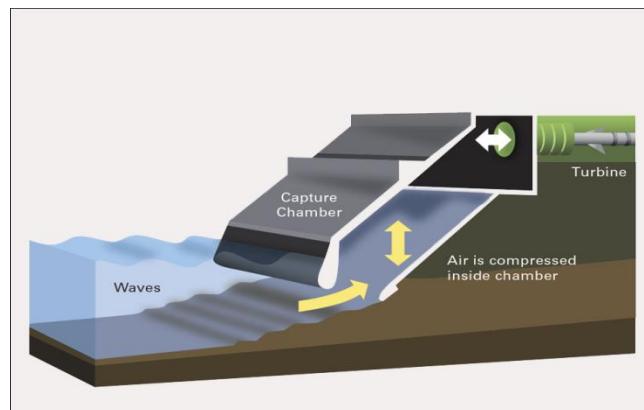

Figure 20 Ocean energy (Source [Ocean Energy](#))

3.5 Wind energy

Wind energy is kinetic energy obtained from the air movements and can be converted to other forms of power like generating electricity using wind turbine or mechanical energy using windmills. The most common application of wind energy is generating electricity using wind farms which includes large number of wind turbines similar to the one shown in figure 21. More than 80 countries are converting wind energy to electricity using wind farms producing 2.5 % of the global electricity needs ⁽¹³⁾

Wind energy is clean source of energy that does not generate GHG's; however, it has some negative impacts on environment related to noise and land usage. Wind energy can best be utilized in areas with high speed of air movement or at high altitude. Offshore locations has shown great significance of wind energy if can be utilized in cost effective way

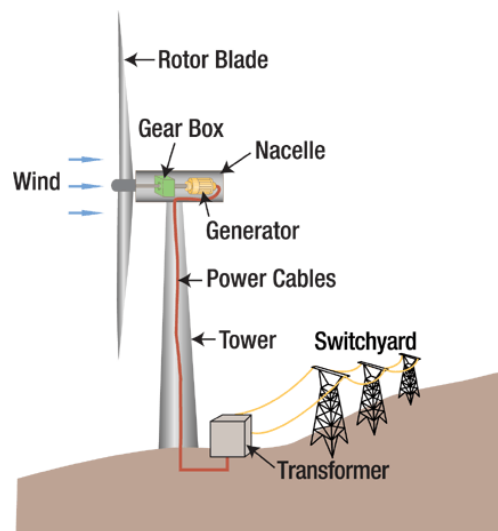

Figure 21 Wind turbine

(Source [TVA website](#))

4 Solar energy

This study focuses on solar energy as it is the best source of renewable energy to be integrated with conventional energy into USOSC

4.1 Background

Solar power history started with life on the earth and in the modern history, solar power was used in wars, industrial, commercial and agricultural applications. Since the mid of 18th century till the first world war one; number of solar technologies were invented to produce heat from sun, operate water pumps in farms and to generate steam. The invention of the first photovoltaic cell was in 1954 in the United States which was used in space industry to generate electricity in space satellites ⁽¹³⁾

Due to the continues increase in global energy needs and due to climate change effects, the world started looking for alternative sources of clean energy to replace conventional sources that can provide the same level of power provided by conventional sources and solar energy is one of the important sources investigated. Compared to other renewable sources, solar has the biggest potential among all the sources available as can be seen in figure 22 below which shows a comparison of the possible potential of different renewable energy sources (2010 conversion efficiencies) ⁽¹⁴⁾

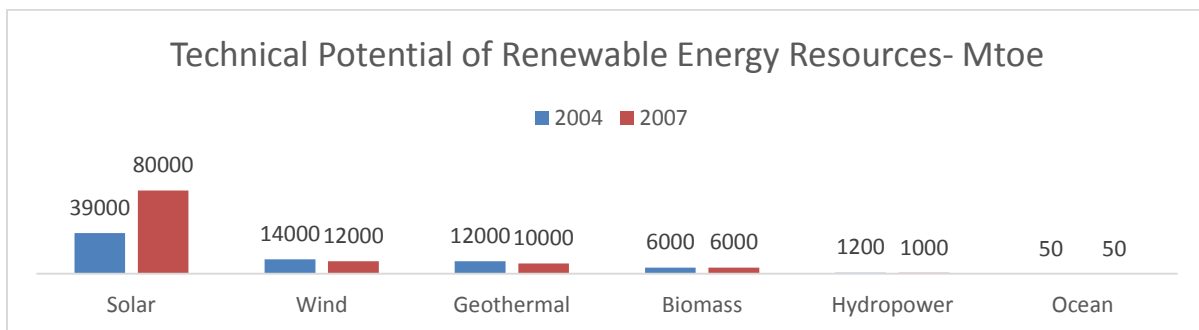

Figure 22 Renewables technical potential (Data source World Bank repor-2011)

More attention was given to solar power after the oil crises in the early 1970's, but this interest disappeared years later in the 1980's due to the very low prices of oil and the absence of good regulations in most of the world countries to support clean energy production at that time. Starting from the beginning of the second millennium, solar energy started to gain interest again due to the increase in oil prices, but this time supported by more regulations encouraging clean energy production. The growth in the solar market since year 2000 was very significant, for example:

- 1- The capacity of electricity generation from solar energy increased to more than 100 GW by end of 2012 compared to 1.4 GW in 2000, see figure 23 and table 3 ⁽¹⁵⁾
- 2- CSP capacity jumped from 14 MW in 1984 to 2550 in 2013, see table 4 and figure 24 ⁽¹⁵⁾
- 3- Solar thermal capacity increased from 44 GW-thermal in 1984 to 255 GW thermal in 2012, see figure 25
- 4- For more information, about electricity generation from renewable energy sources , the reader can refer to US energy information administration website [EIA website](#)

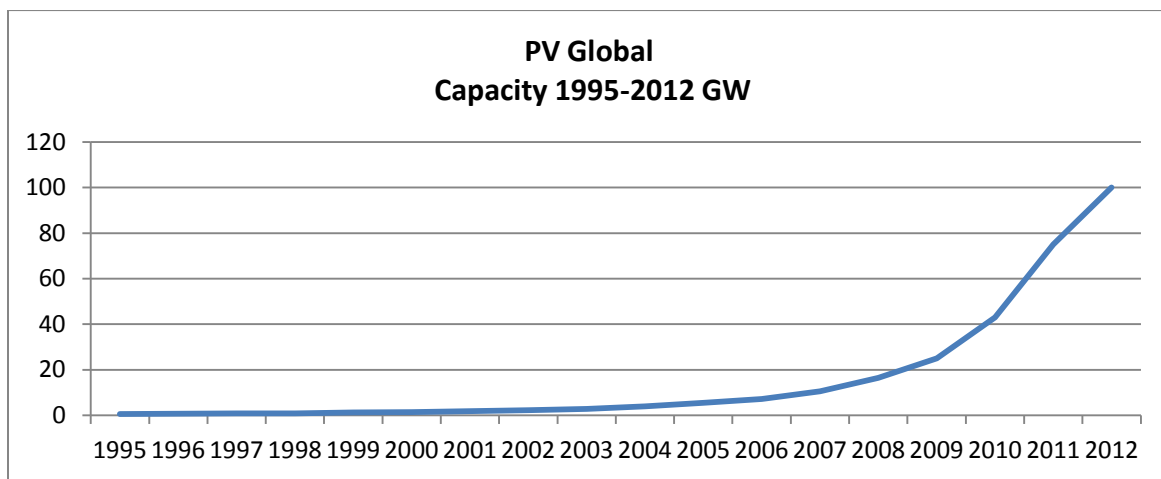

Figure 23 PV global capacity (Data source, RENA21 -2013)

Table 3 PV global capacity GW 2012 *

Country	Installed Capacity 2012 GW	Country	Installed Capacity 2012 GW
Germany	32.5	France	4.1
Italy	16.3	Belgium	2.6
USA	7.3	Australia	2.5
China	6.9	Czech	2.0
Japan	6.7	Rest of Europe	7.5
Spain	5.0	Rest of world	6.8
World Total	100		

*(Data source: RENA21-2013)

Table 4 CSP solar thermal capacity 2012*

Country	Installed Capacity MW	Country	Installed Capacity MW
Spain	1945	Morocco	25
United States	502	Australia	15
Algeria	20	Chile	12
Egypt	23	Thailand	8
World Total	2550		

*(Data source: RENA21-2013)

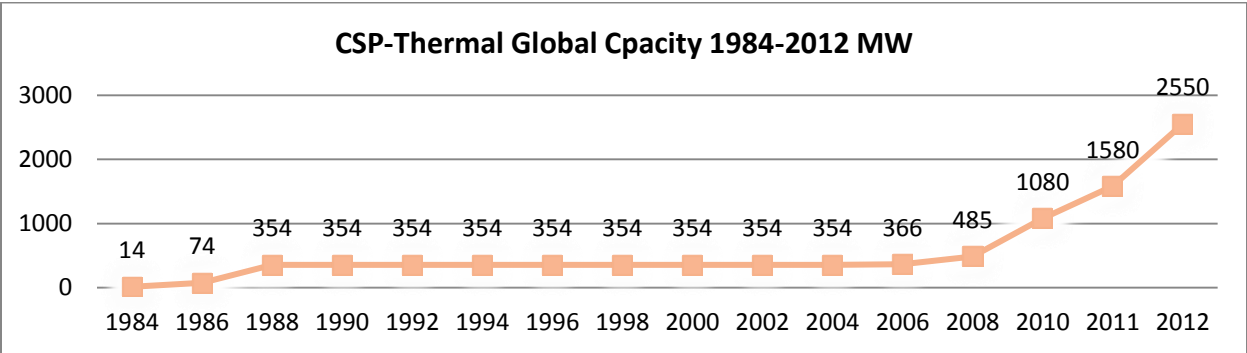

Figure 24 CSP thermal power global capacity

(Data source: RENA21-2013)

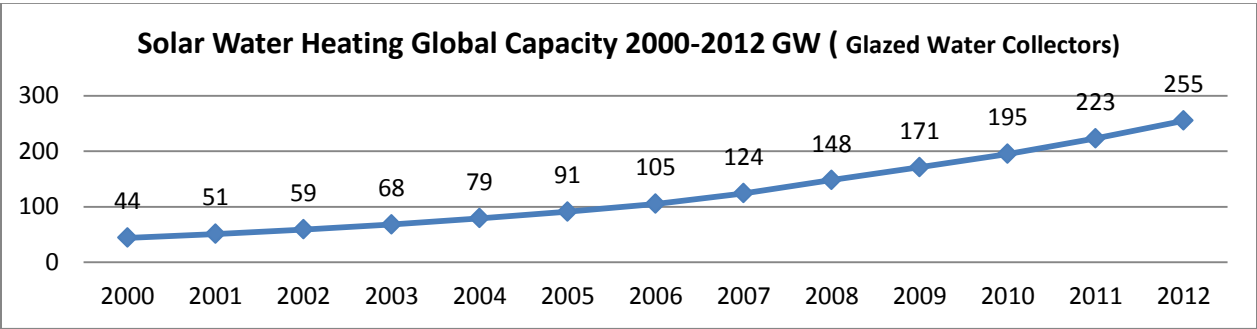

Figure 25 Solar water heaters capacity (Data source: RENA21-2013)

4.2 Theory

Solar energy is defined by its name as the energy generated by the sun by a thermonuclear process which converts around 650 million tons of hydrogen to helium every single second ⁽¹⁶⁾, this conversion generates heat and electromagnetic radiation. The generated heat will stay in the sun to keep the thermonuclear reaction going while the radiations will travel out of the sun into the space of the solar system surrounding the sun

The amount of radiations that reach to earth is very small fraction from the total sun radiations, this small fraction is essential for every life on this earth, and since the fossil fuels were living plants or animals one

day in the past and their life was not possible without the sun radiations, one can claim that the sun is indirectly the source of fossil fuels energy also

It was proved in many studies that the amount of radiations reaching the earth is enough to provide power to the whole world if can be utilized efficiently which is the biggest challenge facing the solar industry as the technological improvements of solar power are still facing complications as will be discussed in the coming sections

Solar power systems usually include two main elements; collection or absorption system and storage system, the collection system will collect the falling radiations and convert them to other type of energy (heat, electricity or both) while storage is required to store the excess energy generated during normal or peak times and supply energy back when radiation levels are very little or not available; like during the night or in some weather conditions like heavy clouds or in winter in addition to supplying energy when collection system can't give all the required energy due to sudden increase in demand or due to system technical difficulties ⁽¹⁶⁾

4.3 Common use of solar power

Solar energy is known to be used to power devices and applications related to heating, electricity generation and transportation and achieved good rates of success in these areas

The highest rates of success were obtained in in heating applications; the heating process does not need- almost- any energy transformation which makes it very efficient. Liquids or packed bed can be used to store energy where packed bed will contain small solid materials (i.e. stones) with very small spaces between them; heat will be held and stored in these small solid objects and heat can be transferred through heating system to the end application

Another application used in industry is utilizing solar energy to change the chemical phase of a certain material from one phase to another (e.g. from solid to liquid) using the heat generated by solar energy, this will store heat in the material itself and can be retrieved (with some losses) by reversing the phase change process where stored heat will be released and captured using other technologies.

One of the very common applications for solar energy is heating water for residential houses; this is very simple demonstration of solar energy use in heating applications. A less common application (due to commercial viability issues) is using solar energy to heat commercial buildings, where large collection/absorption systems need to be installed

Cooling is another application of solar energy which looks strange and this is partially true because cooling using solar energy is very expensive compared to heating which makes it not a well-known or common application. The idea behind this is to change the phase of a material using solar energy and then use the new phase to cool other systems. For example, changing the chemical phase of a certain liquid to gas by adding solar heat then lowering the pressure of the gas while keeping all other conditions unchanged. This will lower the temperature of the gas since temperature is directly proportional to pressure, the gas can be used to reduce the temperature of certain system or area by absorbing heat from it and then sending the gas to another place where the pressure can be increased releasing heat to external surrounding in safe way ⁽¹⁷⁾

One of the very famous and proven applications of solar energy is the generation of electricity, the collection mechanism can be flat-plane or focusing collectors (concentrated solar power – CSP) or using silicon based photovoltaic cells (PV)

The use of photovoltaic cells (PV) is known since more than 50 years, but the challenge was always to increase its efficiency and make it competitive source for electricity generation. Typical photovoltaic cells in the market will have efficiency around or less than 18%. Some cells showed higher efficiency in the lab, but yet to be commercialized

Traditionally, small scale photovoltaic (PV) cells technology was used to generate electricity while modern and recent technologies used concentrated power CSP and large-scale photovoltaic systems to generate electricity connected directly to the electricity grid ⁽¹⁸⁾

Utilizing solar energy in transportation sector is a promising but challenging idea, some installations were done with good rates of success and efficiency. For example sea ships with large size and relatively slow speed can utilize the solar power very efficiently by installing large solar panel on board, while fast moving and small vehicles like cars can be powered by solar energy through batteries charged using solar power at home or dedicated charging station where the battery need to go out of the car for charging and then re-install it in the car

4.4 Advantages of solar energy

Despite all the challenges of solar power, solar energy has many advantages compared to conventional fossil fuels based energy; these advantages can be classified into two main categories of advantages:

- 1- Endless energy from free source
- 2- Clean energy that doesn't destroy the environment

Fossil fuel combustion generates greenhouse emission and pollutes the air which harms the environment and has serious consequences like acid rain and global warming. Solar energy is clean with no pollutant.

Although, solar system site will require construction activities and use of some land which might have slight effects on environment like vegetation disturbance, but this is very small effects compared to the level of construction and land destruction needed for fossil fuel energy production sites. The land use for central solar energy production site can be minimized if solar cells and standalone systems will be more widely used on roofs of residential or commercial building to generate part of the power needed to run its electricity ⁽¹⁶⁾

4.5 Growth

The solar energy industry has grown significantly in the last ten years as a result of two main reasons, the first is the technology improvements which had positive impacts on the financial aspects of solar power industry and the second reason is the improvements of the policies supporting the renewable energy by the world leading countries

The technological development power in the last three decades lead to big reductions in the cost of the solar systems and produced energy, for example: ^{(14) (19)}

- 1- High power band modules cost in 1982 was about USD 27,000/kW, this was reduced to around USD 4,000/Kw in 2005
- 2- The cost of Photovoltaic (PV) system in 1992 was USD 16,000/kW, this was reduced to USD 6,000/kW in 2008

Despite the reduction in solar energy cost, it is still higher than the cost of energy obtained from conventional sources; however, the solar energy takes advantage from financial and regulatory incentives like the tax credit, lower interest rates and preferential feed-in-tariff. Although the solar energy resources is theoretically enough to provide the whole world by the energy needs, the market share of solar energy compared to the overall energy supply from conventional energy sources is still very small ⁽¹⁸⁾

In order for the solar energy industry to replace the conventional sources, many technological improvements need to be done to reduce the solar energy cost and to maintain and increase the incentives for clean energy which have major role in supporting the solar energy industry

Based on the current situation, the integration of renewable energy with conventional energy can be considered as one of the optimum solutions for energy cost reduction while meeting some of the environment protection objectives including the emission targets of Kyoto protocol

4.6 Solar energy technologies

Solar energy technologies can be divided into three linked chains ⁽¹⁴⁾:

- 1- Active and passive
- 2- Photovoltaic and thermal
- 3- Concentrated and non-concentrated

The technology of passive solar energy doesn't convert the collected radiations (or heat) to any other type of energy or application, for example using the collected heat during the day to help in the heating of a building. Active solar energy technology collects the solar energy and either convert it to other applications (can be in another form of energy) or simply store it, active energy has two types; photovoltaic and solar thermal

The technology of photovoltaic (PV) is based on conversion of the energy from collected radiations to electrical energy. The theory behind this is based on electrons excitation when radiations fall on the semiconductor surface which improves its electrical conductivity. Two well-known PV technologies exist in the solar industry today:

- 1- Crystalline silicon PV cells, see figure 26
- 2- Thin film technology, which is produced from number of semi-conductor material, like:
 - a. Amorphous silicon, see figure 27

- b. Cadmium-telluride
- c. Copper indium gallium di-selenide (CIGS)

Figure 26 Crystalline silicon PV cells

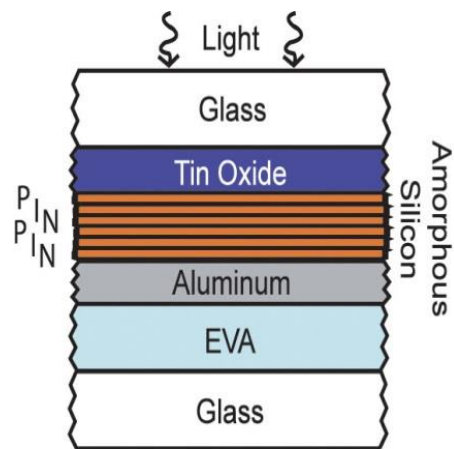
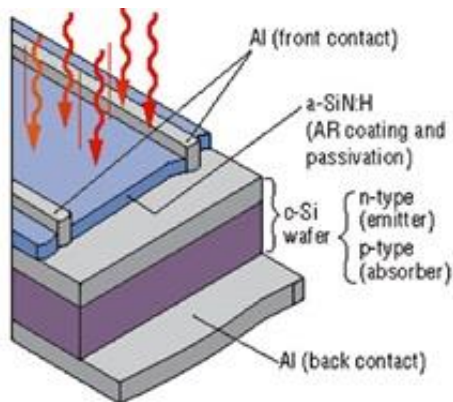

Figure 27 Amorphous cell

(Source [cleangre enenergy zone](#))

Solar thermal technology utilizes the collected heat either for heating purposes or to generate electricity and it includes two main types:

- 1- Non electric solar thermal-
- 2- Electric solar thermal

Solar water heaters and solar air heaters are examples of the first type while generating steam from the collected heat for electricity generation purposes using steam turbines is an example of the second type which is best utilized these days using concentrated solar power technology (CSP) which is divided into four main types ⁽²⁰⁾:

- 1- Parabolic trough, see figure 28

- 2- Fresnel mirror
- 3- Power tower, figure 29
- 4- Solar dish collectors

Figure 28 CSP Parabolic trough

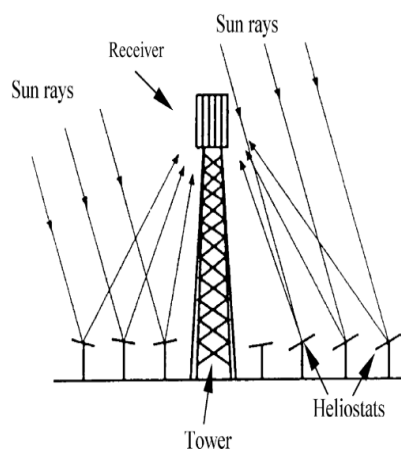
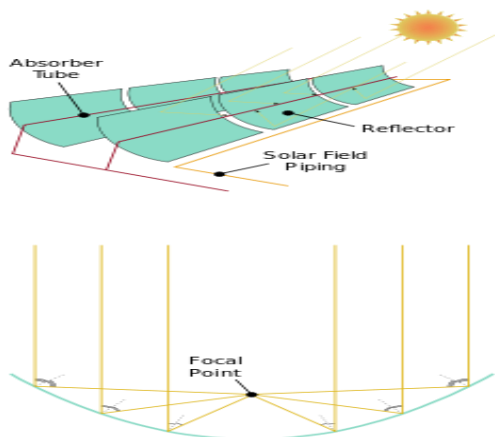

Figure 29 CSP tower

(Source [esw renewable energy study](#))

4.7 Solar energy potential

The range of radiations that can be used for solar energy production starts from 0.06 KW per square meter at high latitude to 0.25 KW per square meter at low latitude. In most of the world regions, the evaluated technical potential exceeds by far the energy demand of these regions. Table 5 below shows different regions with their annual energy demand and the available annual technical potential in these regions in the year 2008 ⁽¹⁴⁾. The lower and upper values obtained in various conditions; like clear sky radiations, sky clearance and area that can be utilized. For full list of the world's radiation based on clear sky, the reader is advised to refer to NASA website for solar radiations (Nasa solar site

Table 5 Solar energy technical potential and energy demand (Mtoe*) in 2008

Location	Potential		Energy requirement	Electricity requirement
	Lower	Upper		
USA & Canada	4300	177000	2730	400
South America	2650	80900	570	75
Europe	690	25000	2000	280
Russia	4752	206681	1038	92
MENA	9800	264000	750	75
Central Africa	8850	227600	500	25
Asia-Pacific	9780	23750	700	75
Asia-South	910	32000	760	60
Asia-central	2750	98750	2215	255
Pacific OECD	1720	54050	875	145

* 1 mega ton oil equivalent (Mtoe) = 11.63 megawatt hours

Source of data : *Govinda R, Timilisin, World Bank report,2011)*

Number of studies came to amazing conclusions about the huge potential and possible advantages of solar energy if can be utilized in cost effective way, for example:

- 1- Installing PV cells on (4%) of the total area of the deserts in the world can generate electricity enough to meet the world demand-based on 2005 consumption ⁽²¹⁾
- 2- installing PV cells on 0.71% of the Europe land area can generate electricity enough to meet all Europe's demand- based on 2010 consumption ⁽²²⁾

- 3- Installing CSP on 1 % of the Westland-china (26,300 km²) is enough to produce 1300 GW of electricity which is twice the whole country projection in 2020 ⁽²³⁾
- 4- Installing CSP on 23,500 km² in the southwestern part of the United States can produce 1,067 GW of electric power equivalent to the whole country consumption in 2010 ⁽²⁴⁾

4.8 Solar radiations

All materials with temperature above zero generate energy in the form of radiations with different wavelengths. Materials with high temperature will have short wavelength peak (very hot objects will generate gamma ray and x-ray) while materials with lower temperature will have long wavelength radiations, like lights and radio waves ⁽²⁵⁾

The temperature of the sun’s surface is around (5500) °C and majority of the energy radiated by the sun is visible, the distance from the sun to the earth is around (150,000,000) km and the solar energy intensity that reaches the upper atmosphere known as the total solar radiation or “solar constant” is around 1365 watts/m² ⁽²⁵⁾.

The effective temperature of earth is -20 Celsius (earth temperature as seen from space) and the earth energy radiates infrared wavelength, see figure 32

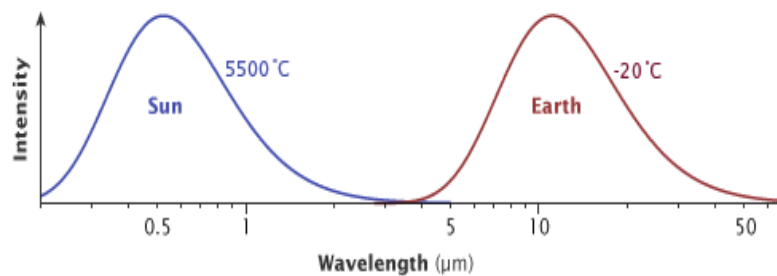

Figure 30 intensity vs. wavelength (Source: Observer website)

4.8.1 Effective radiations

Because of the earth's shape, the amount of radiations reaching the earth at any point of time is one half of the maximum potential of solar power that can be collected in one day because one side of the earth is always dark when the other side is receiving the sun radiations. The intensity spreading of the radiation is not equal also, the locations closer to the sun will receive the maximum irradiance intensity and less intensity will be found as we move from equator to the poles. See figure 32

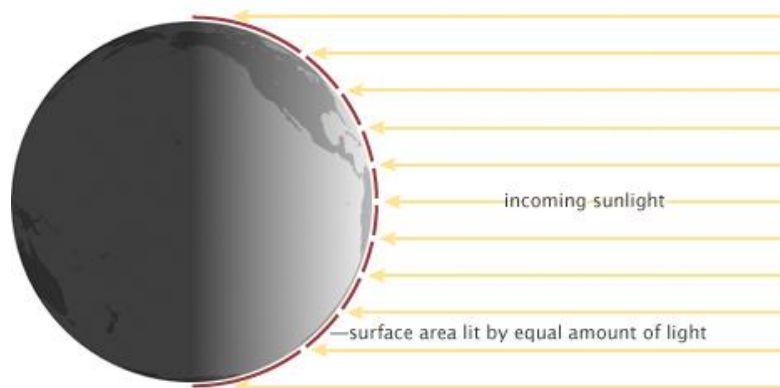

Figure 31 Effective radiations (Source: Observer website)

The total solar radiations is calculated as the amount that can be received when the sun light is perpendicular to the receiving spot and since the light in locations other than equator is received with an angle; the total solar radiation is again cut into half which makes the quantity of radiation reaching the earth one quarter of the maximum daily potential, the solar irradiance is also different from one time during the day to another based on the sun's angle with earth's surface. The total received amount is around 340 watts/m^2 per day (global) and the possible capturing percentage of falling radiation on different location can be described as the followings ⁽²⁵⁾:

- 1- Around (90)% of the total possible solar energy falling is received by the tropics (compared to the equator) where radiation angle is almost perpendicular

- 2- Places at 45°, receive around (70-75) % of the total possible radiation had these locations been perpendicular to the sun radiation
- 3- 40% is received by the northern and southern pole

4.8.2 Radiation maps

Another important term in the solar radiation analysis is the “diffuse horizontal irradiance” which is the irradiance that hit the earth’s surface after scattering in the air by different molecules. The diffuse irradiance can be added to the direct horizontal irradiance which hit the earth directly without being scattered or absorbed by air molecules to give the total global horizontal irradiance defined as the sum of the direct and diffuse irradiance. Figure 34 shows the world’s solar energy map and the radiation maps for different regions in the world is available at Solar GIS website ([Solar GIS](#))

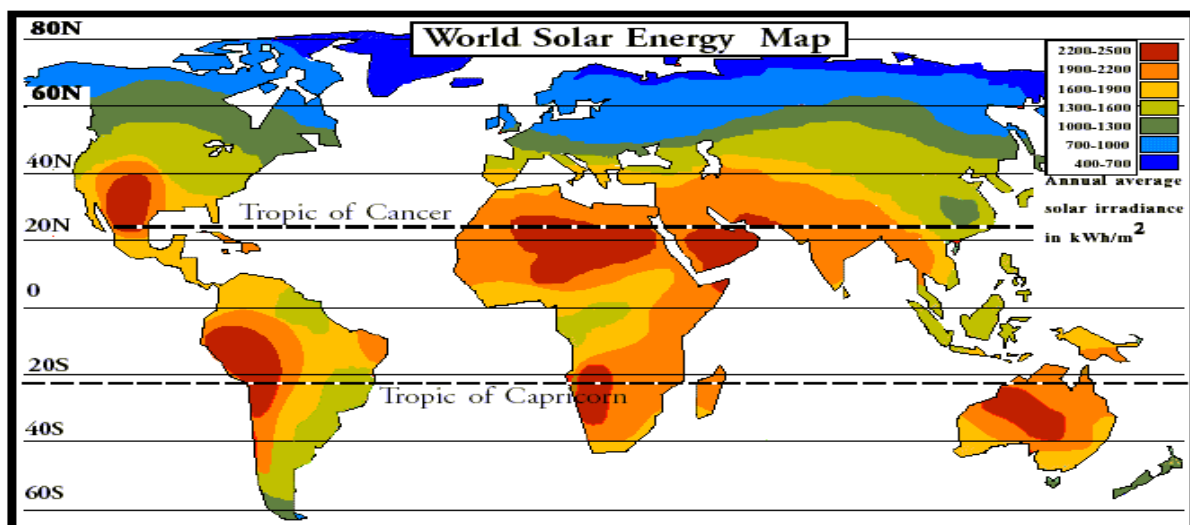

Figure 32 World's solar energy map (Source [EUROPE Solar infor](#))

4.9 Solar energy economics

The competition level between solar energy and conventional energies differs from one solar technology to another based on the technology type and application. For example, big scale photovoltaic and concentrated solar technologies compete with conventional energy sources used for electricity generation purposes serving central grids while smaller solar energy systems, like stand-alone systems, compete with diesel or similar fuel used to run small and medium equipment

Many of the investigated studies used similar principles to compare the cost of electricity generation from renewable and conventional sources, this principle is called “levelized” cost method and can be represented by the following equation ⁽¹⁴⁾:

$$LCOE = \frac{OC}{CF \times 8760} \times CRF + OMC + FC$$

$$\text{Where } CRF = \frac{r \times (1 + r)^T}{(1 + r)^T - 1}$$

OC: Investment cost not considering the interest rate payment during the plant construction; it is also called “overnight construction cost (OC)”

CF: Capacity factor

CRF: Capital recovery factor, which is the ratio of the fixed payment “annuity” to the present discounted value

FC: the series of annualized fuel costs

T: predicted productive life of the power plant

r: Discount rate or interest rate

This method is useful at the time of calculations when all variables are fixed, it needs to be updated with time to take the changes in energy cost into consideration; like the cost reduction in solar technologies due to continuous technological improvements, changes in oil prices in addition to changes in capital cost which plays major role in the competitiveness of solar energy.

This method is used here to give an indication about the difference in competitiveness between solar energy and conventional energy sources at present time, reaching to a conclusion that solar energy needs more focus and attention by researcher, industrial companies and other involved parties to achieve remarkable improvement on the technology to make it competitive in addition to governments support to put more measures in the energy policies to promote clean energy production

The comparison below is focused on PV and CSP connected to the grid, the data were obtained from the following sources:

- 1- Lazard financial advisory, LCOE report version 5.0 ⁽²⁶⁾
- 2- International energy agency (IEA)report “Projected cost of generating electricity”- 2010, Pages (17-25) ⁽²⁷⁾
- 3- Energy international agency and emerging energy research study ⁽²⁸⁾

The studies included calculations that used different numbers obtained in previous years based on different inputs like plant life, interest rate and capacity factor. For example; the first study by Lazard, 2009 considered finance costs (i.e taxes) while IEA study in 2010 didn’t consider these costs.

To overcome this and make numbers consistent, lower and upper values for OC were considered to give different scenarios; in addition an increase of 10% on the O&M reported cost and 7.5 % discount on fuel prices were considered. Also because the data were obtained in previous years, an inflation factor was considered to adjust the value to match present values. The summary of the results is shown in table 6 and figure 36 (the IGCC term refer to the “integrated gasification combined cycle” carbon capturing and storing- CCS” while the numbers used for the coal is for supercritical coal)

Table 6 Economic analysis inputs

Technology	OC (US\$/kW)	Plant life (years)	CF (%)	LCOE
------------	-----------------	-----------------------	--------	------

Technology		OC (US\$/kW)	Plant life (years)	CF (%)	LCOE
Photovoltaic	Lower	3252	20	20	173
	Upper	8341	20	20	705
Solar CSP	Lower	4912	20	30	325
	Upper	6554	20	25	176
Wind	Lower	1382	20	25	75
	Upper	4199	20	25	220
Gas CC	Lower	608	25	80	65
	Upper	2950	25	80	150
Coal	Lower	2212	35	80	42
	Upper	2869	35	80	89
Hydro	Lower	855	75	30	30
	Upper	3901	25	30	102
IGCC	Lower	4033	35	80	81
	Upper	7083	35	80	159
Nuclear	Lower	3830	50	25	77
	Upper	9464	25	90	144

As seen in the results, the cost of solar energy for electricity generation is higher than conventional energy except for IGCS despite the significant improvements of solar technologies in the last ten years. However, the LCOE for solar PV technology based on lower OC value is USD 173 per MWh and USD 176 for CSP based on lower OC value which is much higher than LCOE for coal with CCS (USD 42 per MWh)

The LCOE is affected by the values of capital cost, O&M and fuel cost, in most of solar energy technologies, capital cost is around 80 of the total cost, while it is around 60% for fossil fuels including coal and IGCC. In addition, fuel cost has major effect on fossil fuel technologies cost; in other words, the challenge to make solar energy competitive is to focus on reducing the capital cost including the material and system integration costs

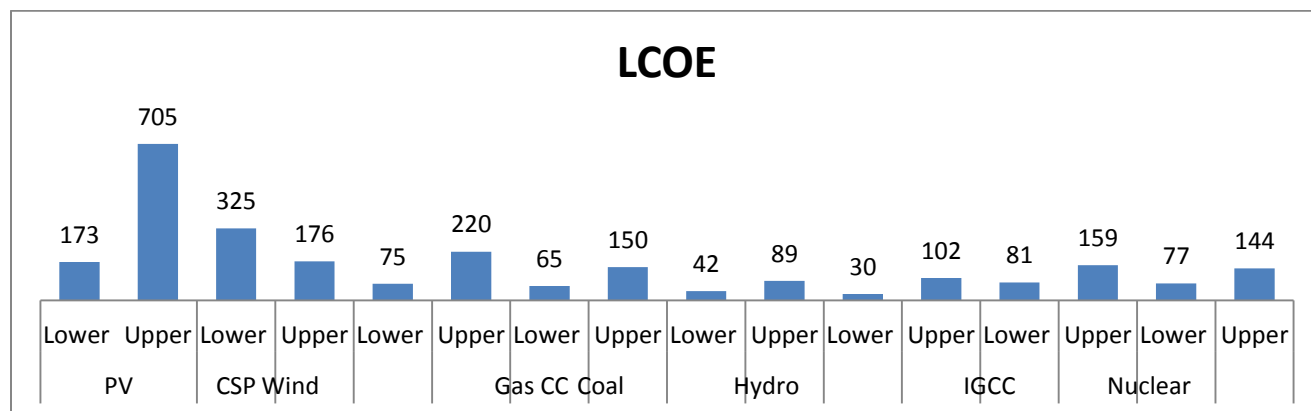

Figure 33 LCOE USD/MWh

Although LCOE is major factor in assessing the financial viability of any solar project, but other cost factors can be considered in the overall cost calculations of solar energy competitiveness when compared to energy provided by conventional sources; like the cost of environment destruction caused by solar energy compared to the cost of conventional sources. However, it is a very complex process to calculate the actual cost of the environment damage. To consider the cost of environment damage and compare the LCOE of solar to LCOE of conventional sources; a sensitivity analysis approach is shown in figure 34 t assuming different values for environment damage cost (from Zero USD per ton CO₂ to USD 100 per ton CO₂)

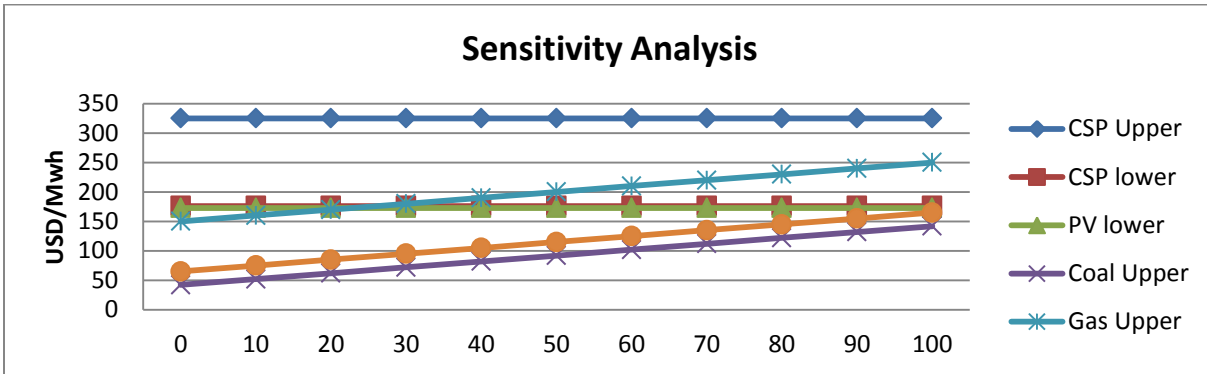

Figure 34 LCOE sensitivity analysis

It is clear from the figure 34 that the LCOE of solar energy will remain high compared to maximum value of conventional sources even with considering the maximum destruction cost; however, this is based on the current prices of fuel and solar technologies

The question that needs further investigation to find the accurate cost comparison between clean and conventional technologies is directly related the options that humanity will have in 100 years from today if the oil era (as a major source of conventional energy) will come to an end which will add another important dimension to the cost comparison equation; what is the cost that humanity is willing to pay to keep prosperity development by investing in sustainable and clean sources of power?

4.9.1 Cost of solar power

The cost of solar power technologies depends on number of variables, including the followings:

- 1- Type of technology
- 2- Output requirements
- 3- System design

General indications for the cost of energy generated by different solar technologies for different applications are listed in table 7 below ⁽¹⁵⁾

Table 7 Solar energy cost

Technology	Characteristics	Capital Cost \$ U.S/KW	Standard Energy Costs (USD/kW)– U.S. cents/kWh)
Solar PV (Rooftop)	Capacity: 4–6 Kw (houses); 100-120 kW (business) 500 kW (manufacturing- Capacity factor: 10–25% (fixed)	2,275 (Residential, Germany) 4,300–5,000 (Residential USA) 1,500–2,600 (Industrial, Global)	20–46 (OECD)* 28–55 (non-OECD) 16–38 (Europe)
Solar PV: Ground-mounted utility-scale	Peak capacity: 2.5–250 MW Capacity factor: 10–25% (fixed) Conversion ratio: 10–30%	1,300–1,950 (Global) Averages: 2,270 (USA) 2,760 (Japan); 2,200 (China);	12–38 (OECD) 9–40 (non-OECD) 14–34 (Europe)
Concentrating solar thermal power (CSP)	Parabolic trough Fresnel, tower Plant capacity:50–250 Mw trough; 20–250 Mw-tower; 10–100 MW (Fresnel),	Trough, without storage: 4,000–7,300 (OECD); 3,100–4,050 (non- OECD). Trough with 6 hrs storage: 7,150 –	Trough and Fresnel: 19–38 (without storage)

	Capacity factor: 20–40% (without storage) and 35–75% (with storage)	9,800 for tower with (6–15) hrs:6,400–10,800	17–37 (6 hrs. storage) Tower: 0–29 with (6–7 hrs storage) 12–15 (12–15) hrs storage)
Solar thermal: Hot water Systems (domestic)	Collector type: Flat-plate, evacuated tube pumped Systems Plant size: 2.1–4.2 kWth (one family) , 35 kWth (multiple) Efficiency: 100%	One-family: 1,100–2,140 (OECD), new) 1,300–2,200 (OECD, renovated) , (150–635 (China). Multiple-family: 950–1,850 (OECD) . ,140–2,050 (OECD, renovated)	1.5–28 (China)
Solar thermal: Hot water and domestic heat	Collector type: same as water only Plant size: 7–10 kWth (One-family); 70–130 kWth (multiple-family); 70–3,500 kWth (district heating); >3,500 kWth (district heat with seasonal storage) Efficiency: 100%	One-family: 1,100–2,140 (OECD), new), 1,300–2,200 (OECD, renovated), 150–635 (China) Multi-family: 950–1,850 (OECD) 1,140–2,050 (OECD, renovated) , District heat (Europe): 460–780; no storage: 470–1,060 (with storage)	5–50 (domestic hot water) District heat: 4 and more (Denmark)
Solar thermal:	Collector type: flat-plate, evacuated tube, parabolic trough, linear Fresnel	470–1,000 (No storage)	4–16

Heat for Industrial use	Plant size: 100 kWth–20 MWth Temperature range: 50–400° C		
Solar thermal: Cooling	Capacity: 10.5–500 kWth. (absorption chillers); 8–370 kWth (adsorption chillers). Efficiency: 50–70%	1,600–5,850	NA

Source of Data: RENA21-2013

* Organization for Economic Co-operation and Development

4.10 Future growth

To answer the question about the cost that humanity is willing to pay in order to maintain prosperity, an analysis for the projection of the solar energy future and the challenges facing the development of solar energy technologies are been investigated

An analysis was done for number of studies that predicted the future of solar energy taking number of factor into consideration, the analyzed studies include:

- 1- Study by Cambridge university ⁽¹⁷⁾ supports the idea that solar growth will be driven by climate change and draw two scenarios:
 - a. One scenario without governmental policies to mitigate climate change which this will lead to a solar energy installment of 1 to 12 EJ per year in the year 2050.
 - b. The other scenario considered the existence of governmental policies to mitigate climate change to keep CO₂ concentrations less than 440 ppm by 2100 and concluded that the deployment of solar energy can reach 39 EJ per year in 2050
- 2- Study by European Photovoltaic Industry Association EPIA/Greenpeace International ⁽²⁹⁾ predicted that:
 - a. The total installed base of PV by 2030 will reach 1845 GW based on assumptions that current markets support and additional market support will be introduced.
 - b. The solar PV global production capacity will be around 1000 GW in 2030 regardless of the policies and market support
- 3- A study by the European renewable energy council and Greenpeace international ⁽³⁰⁾ concluded that PV production capacity will exceed 2033 GW in 2050
- 4- A study by the International Energy Agency (IEA) ⁽²⁷⁾ considered two scenarios:
 - a. The first scenario to keep the CO₂ emission levels similar to the year 2005 and expected that PV capacity will reach 600 GW in 2050

- b. The second scenario proposed (50) % reduction in 2005 CO₂ levels by the year 2050 and projected that total PV capacity will reach 1100 GW by 2050
- 5- A study by the European solar thermal power industry (ESTIA), Greenpeace and the International energy agency (EIA) expected that the capacity of concentrated solar power (CSP) will reach 37 GW by 2025 and 600 GW by 2040 ⁽³¹⁾
- 6- A study by EREC and green peace ⁽³⁰⁾ expected that the capacity of CSP will increase to 30 GW in 2020, 137 GW in 2030 and 405 GW by 2050
- 7- A study by IEA ⁽²⁷⁾ analyzed two scenarios for CSP:
 - a. The first scenario is based on 2005 GHG emission levels and expected that the CSP capacity will be 380 GW by 2050
 - b. The other scenario based on (50) % reduction of 2005 GHG emission levels by 2050 predicted that CSP capacity will hit 630 GW by 2050
- 8- IEA study ⁽²⁷⁾ predicted that thermal energy demand will reach 60 Mtoe in 2030
- 9- EREC ⁽³⁰⁾ predicted in 2004 that thermal solar will increase significantly and reach more than 60 Mtoe in 2020, 244 Mtoe in 2030 and 480 Mtoe in 2040
- 10- EREC also projected in 2004 that solar energy will supply (11)% of the total energy demand by the whole world in 2040: PV will give (6)%, solar heating (4)% and (1)% from CSP

Despite the very promising projections, there are still number of challenges that solar energy needs to overcome to make future projections more realistic

4.11 Challenges

The challenges facing the solar energy used in electricity generation and solar thermal applications can be summarized into three main groups: Technical, economical and regulation/institutional

4.11.1 **Technical**

Each type of the solar technologies has different technical challenges than the other types. For example, the biggest technical challenges for PV are the conversion ratio or efficiency and overall system functionality challenges (like batteries technical functionality). For PV standalone systems, the biggest technical challenge is the storage capabilities in addition to batteries recycling.

In case of solar thermal technology, the biggest technical challenges are the fluid heat capacity and losing heat in storage

4.11.2 **Economic**

The biggest economic challenge is the initial cost of solar technology divided by the power output compared to the same in conventional technology which doesn't work to the advantage of the solar power for two main reasons:

- 1- The low cost (relatively) of hydrocarbon
- 2- The maturity and consistency of production technologies for conventional energy compared to the solar technologies

The financial aspects of investing in solar energy is another challenge; investors usually look into opportunities with high return on investment and shorter payback period which is not the case in solar industry although the investment analysis (in most cases) don't consider (or slightly consider) the indirect economic impacts of conventional energy sources on health and environment

4.11.3 **Institutional**

The manpower development and skills training are the biggest institutional challenges facing solar technology development as most of the workforce prefers well- defined industries with clear career progression plans in addition to bureaucracy which plays a role in the slow development of solar technology, table 8 below list the main challenges facing the different types solar technologies ⁽¹⁴⁾

Table 8 Solar energy challenges

Technical	
PV	<p>1- Efficiency:</p> <ul style="list-style-type: none"> • Thin film: 4% to 12% • Crystalline: below 22% <p>2- Performance challenges “Systems components balance ; i.e battery and inverter</p> <p>3- Supply chain:</p> <ul style="list-style-type: none"> • Availability of silicon in proper timing and maintain good levels of supply could be critical to the PV industry • Same challenge for certain types of PV using Cadmium and tellurium, since these two products are obtained (as by products) from zinc and copper industries, their supply will rely on the zinc and copper industry
Thermal	<p>1- Transfer fluid thermal capacity</p> <p>2- Storage losses</p> <p>3- Design of supply direction in case of multiple products are needed</p> <p>4- Difficulty of integrating water heaters with existing infrastructure and existing buildings setup</p>
Economic	

Technical	
PV	<ul style="list-style-type: none"> 1- High upfront cost in the beginning of the project development 2- Difficult to find proper long-term financing 3- Investing in PV technology is considered as high risk due to low IRR compared to other more profitable investments 4- Balance of system cost reduction is not in line with the cost reduction of solar PV modules 5- Failure of number of PV partnership projects due to one of the partners leaving the JV (or alliance) leading to partnership failure, which affected the PV industry reputation
Thermal	<ul style="list-style-type: none"> 1- High capital cost 2- Long time to break even investment cost 3- Low IRR for house water heating application 4- Additional cost needed to obtain good heating source to for the backup heaters 5- High cost of the material used in the water distribution like cooper for example
Institutional	
PV	<ul style="list-style-type: none"> 1- Lack of training resources that can train enough work force to work in the developed solar power projects 2- Bureaucracy, due to the need of working of many authorities
Thermal	<ul style="list-style-type: none"> 3- Need for clear system of metering and billing in case of selling back extra energy back to the grid

5 Solar energy in USOSC

This section investigates the possible uses of solar power in the oil and gas industry through identifications of possible areas for solar power integration in oil processes with the view to achieve the following objectives:

- 1- Maximize or maintain same operation efficiency
- 2- Cost advantages
- 3- Reduce GHG emissions
- 4- Overcome technical difficulties in remote oil production sites related to providing continuous and cost-effective power supply

5.1 Integration areas

The use of solar energy in oil and USOSC can be classified into three main groups:

- 1- Electricity generation
- 2- Heat supply
- 3- Steam production

Three shapes of solar energy sources can be used to provide power in USOSC;

- a) Standalone system, see fig 35
- b) Hybrid system
- c) Grid connection

5.2 Applications

The possible applications of solar energy integration in USOSC are listed in table 9, a detailed analysis for the best area for solar energy and the type solar energy to be integrated is carried out in the case study section

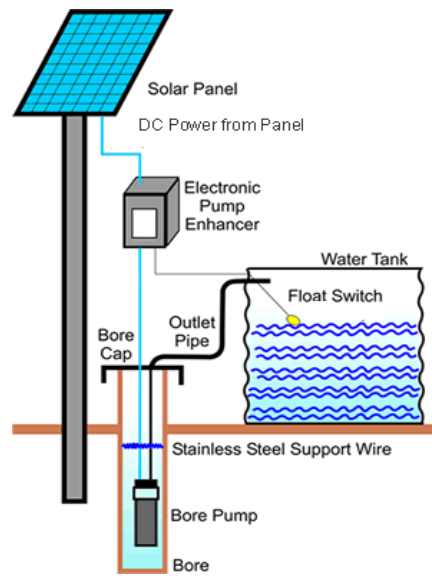

Figure 35 PV stand-alone (Source [omansolar](http://omansolar.com))

Table 9 Solar in USOSC

Application	Solar Area	Application	Solar Area
EOR	Steam generation	Drilling meters	Electricity
RTU's	Electricity	Cathodic protection	Electricity
Telecommunication	Electricity	Process control	Electricity
SCADA	Electricity	Lighting	Electricity
Flow measurement	Electricity	Water heaters	Heat Supply

5.2.1 Telecommunication

Although telecommunication devices are very crucial in USOSC operations specially during un-usual times (i.e. shutdown, accidents...etc.), the amount of electrical power needed to run these equipment is small compared to other operations and over all power requirements. Solar energy can be very good source to generate electricity to feed the telecommunication equipment (mainly in remote areas) with

power using either PV stand- alone systems as seen in figure 36 or through electricity generated by steam turbines as explained in the case study section

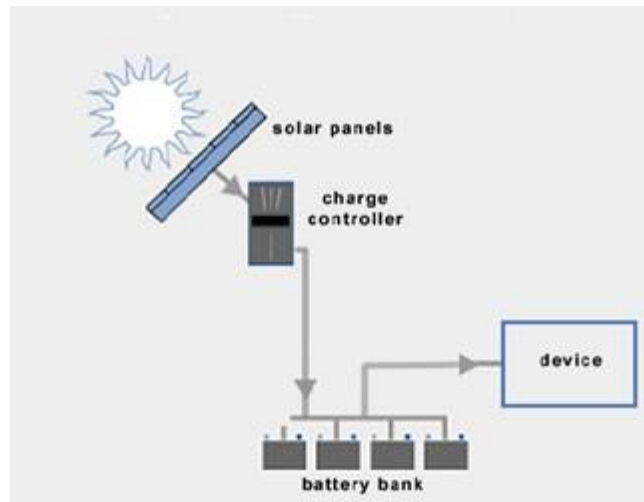

Figure 36 Soar for telecommunications (Source [wholesalesola](http://wholesalesola.com))

5.2.2 Remot terminal units and SCADA

Data collection from wellheads using remote terminal units (RTU's) and transmission to control system and data acquisition (SCADA) plays essential role in operations planning, like controlling the gas feed and pressure used in oil lifting for example. Electricity generated using solar generated steam turbines or solar PV stand-alone system as seen in figure 37 integrated with direct electricity source can provide the required power during the radiations peak times or from storage system during night

5.2.3 Cathodic protection

Corrosion is big problem for oil companies as it is a main reason for leaks in pipelines leading to loosing valuable quantities of oil and causing serious damages to the environment including the release of greenhouse gas emissions. A lot of money is paid every year by oil companies to fight corrosion and one

of the proven methods to control corrosion is cathodic protection systems which are widely used in remote locations. Powering the remote sites with electricity from conventional sources might be difficult and expensive thing to do, therefore, powering cathodic protection systems with electricity generated by stand- alone PV solar system supported by storage capacity can be very good solution to optimize the energy usage mix in remote locations, see figure 38

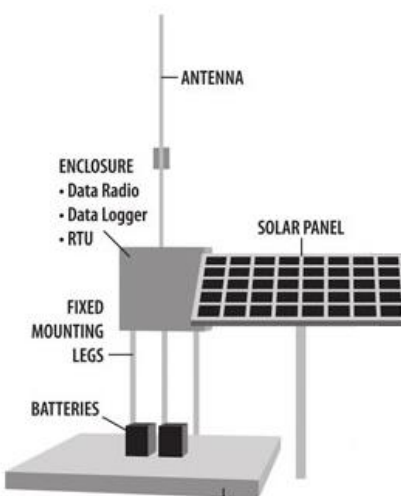

Figure 37 Solar RTU

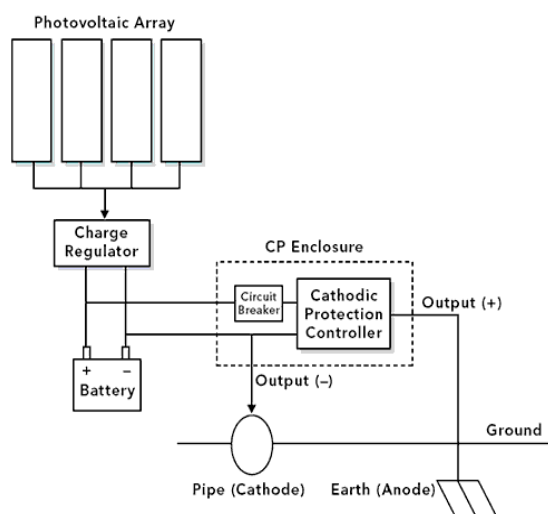

Figure 38 Solar cathodic protection

(Source whole sale solar website, [wholesalesolar](http://wholesalesolar.com))

This study focuses on generating steam from concentrated solar power for enhanced oil recovery purposes and electricity generation using steam turbine

5.3 Solar-Steam for EOR

Numbers of projects to generate steam from solar power were successfully introduced to the USOSC operations in the last few years. The idea is simple; reflection mirrors will concentrate the sun light to heat water stream inside circulation pipes till reaching the steam phase at high pressure, or using heat

transfer fluid followed by heat exchanger and steam booster to generate steam, this steam is then directed to the injection well for enhanced oil recovery operations as seen in figure 39

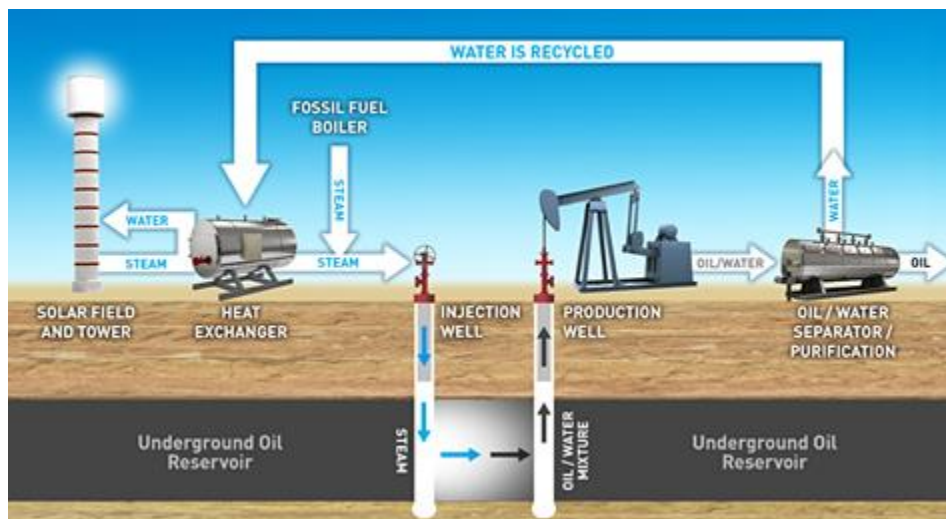

Figure 39 Solar EOR (Source PV magazine pv-magazine.com.)

One of the important design factors in the steam generation process is the availability of sunlight during the day and night, which leads to variable steam generation rates due to day and night cycle in addition to the changes in weather condition in different seasons which causes variation in steam generation rates and this need to be given special attention in the process design, specially the difference between summer and winter radiation values and effective storage capacity

An investigation is carried out to assess the impacts of using steam generated by solar energy (variable generation rate) and steam generated from gas combustion sources (constant generation rate) on the efficiency of enhanced oil recovery operation and the following conclusions summarize the investigation outcome: ⁽³³⁾

- 1- In locations with good rates of solar radiations (an average of 120 kWh/m².month or 4 kWh/m².day) supported by (5-6) hours storage capacity; the day and night cycle have small effects on the normal EOR operations

- 2- In most of the oil production locations, the seasonal cycle in solar-steam generation is in-line with the oil seasonal production rates cycle
- 3- During the same time window, the total amount of solar-steam re-injected is almost equal to the total amount of steam generated from gas burning
- 4- Generating steam from solar energy is good replacement to steam generated from burning gas

5.3.1 Solar-steam projects

In the last ten years, number of solar steam projects was introduced to the USOSC operations in different parts of the world with different production capacities using different technologies while sharing the same technological principles. They are all located in areas with good solar radiation intensity; the projects that achieved the highest rates of success are the followings:

5.3.1.1 Berry Petroleum, McKittrick- California

The first project of its kind in the world to produce steam from solar power for enhanced oil recovery operations, the project came to existence in February 2011, it was designed and installed by Glass point company ([glasspoint](#)) at Berry petroleum company site at Kern-California, the project uses CSP trough technology to generate steam by directly heating a stream of water flowing inside the circulation pipes (no heat transfer fluid used) to change its phase to steam and then send it to steam booster to generate superheated steam. The project is designed to produce one million Btu/h

5.3.1.2 Chevron, Coalinga-California

This project is located at Chevron site in Coalinga-California and started operation in September 2011. The project was designed and installed by Bright source company to produce 29 MW using 3822 mirrors that concentrate the sunlight on a solar boiler tower (as shown in figure 40) which produces steam at high pressure to be injected into the reservoir for EOR operations ⁽³⁴⁾



Figure 40 Bright source installation at Chevron, Coalinga

(Source: Bright source company website <http://www.brightsourceenergy.com/>)

5.3.1.3 Petroleum development Oman-Shell

This project uses the same technology of Berry petroleum installation as it was designed and installed by the same company (Glass point) for the use of Oman Oil Company, the project started operations mid of 2013 and designed to produce 50 ton of steam per year for EOR operations

6 Case Study

The objective of this study is to propose a solar technology to be integrated in the USOSC to feed production areas with high levels of GHG emissions and at the same time consuming large amounts of energy. However, as seen in the previous sections, number of factors makes such proposal a complex process, including the followings:

- 1- The estimate of the energy requirements for each process, equipment or group of equipment is complex task that includes many variables affecting the amount of energy consumed
- 2- The accuracy of the greenhouse gas emissions estimate varies from one methodology to another and variance can reach up to (30)%
- 3- The selection of solar energy depends on the type of application in the USOSC process, size and availability of land, radiation intensity and many other factors

The above points make the matrix of energy requirements, greenhouse emission and solar technology complex to be analyzed unless assumptions are made. To start the analysis process; two sets of questions will be investigated to simplify the options matrix:

6.1 Set one

- 1- Which operation in USOSC?
- 2- Which solar technology to use: PV or CSP?
- 3- When solar technology is selected, what specific type of solar technology to use?
- 4- Where? What location?

5- What is the level of investment needed; small or large?

6.2 Set two (assumptions)

- 1- What is the assumed oil production capacity?
- 2- What is the solar system capacity? (can make multiple scenarios)
- 3- What methodology will be used to calculate GHG?
- 4- What is the CO₂ credit value?
- 5- What are the other assumptions that might be needed?

Table 10 summarizes different variables that can answer the above questions

Table 10 Options matrix

		Option 1	Option 2	Option 3	Option 4
USOSC	Process	EOR	Drilling	Unit Operation	Transportation
	Application	Electricity Generation	Steam generation	Small systems : (i.e RTU's/ telecommunications)	
Solar	Technology	CSP Trough	Large scale PV	Stand-alone PV system	
		CSP Tower			
		CSP Dish			
	Storage (hours)	No storage	1-3	4-6	More than 6
	Cooling	Dry cooling		Water cooling	

Location	High radiations	Middle East- Gulf countries	North Africa	Australia	South America
	Medium-High	Other middle east countries	India	China	North America-west coast
Oil Productio n	Capacity tons/year	500,000	1,000,000	2,000,000	Others
Power (if electricity)	Capacity (MW)	20	50	100	Others
	Conversion Efficiency	Low	Medium	Medium-High	
	Grid Connection	Predictable		Not Predictable	
Land	Km ²	Less than 2	2-5	More than 2	
Financials (compare d to conventio nal sources)	CAPEX	Low	Medium	High	
	O&M	Low	Medium	High	
	ROI	Low	Medium	High	
	Payback period	Short		Long	
	LCOE	Low-Medium		Medium-High	

In order to simplify the complexity of the options matrix, an analytical approach is used (shown in figure 42) based on selection criteria of each stage as discussed in the below sections

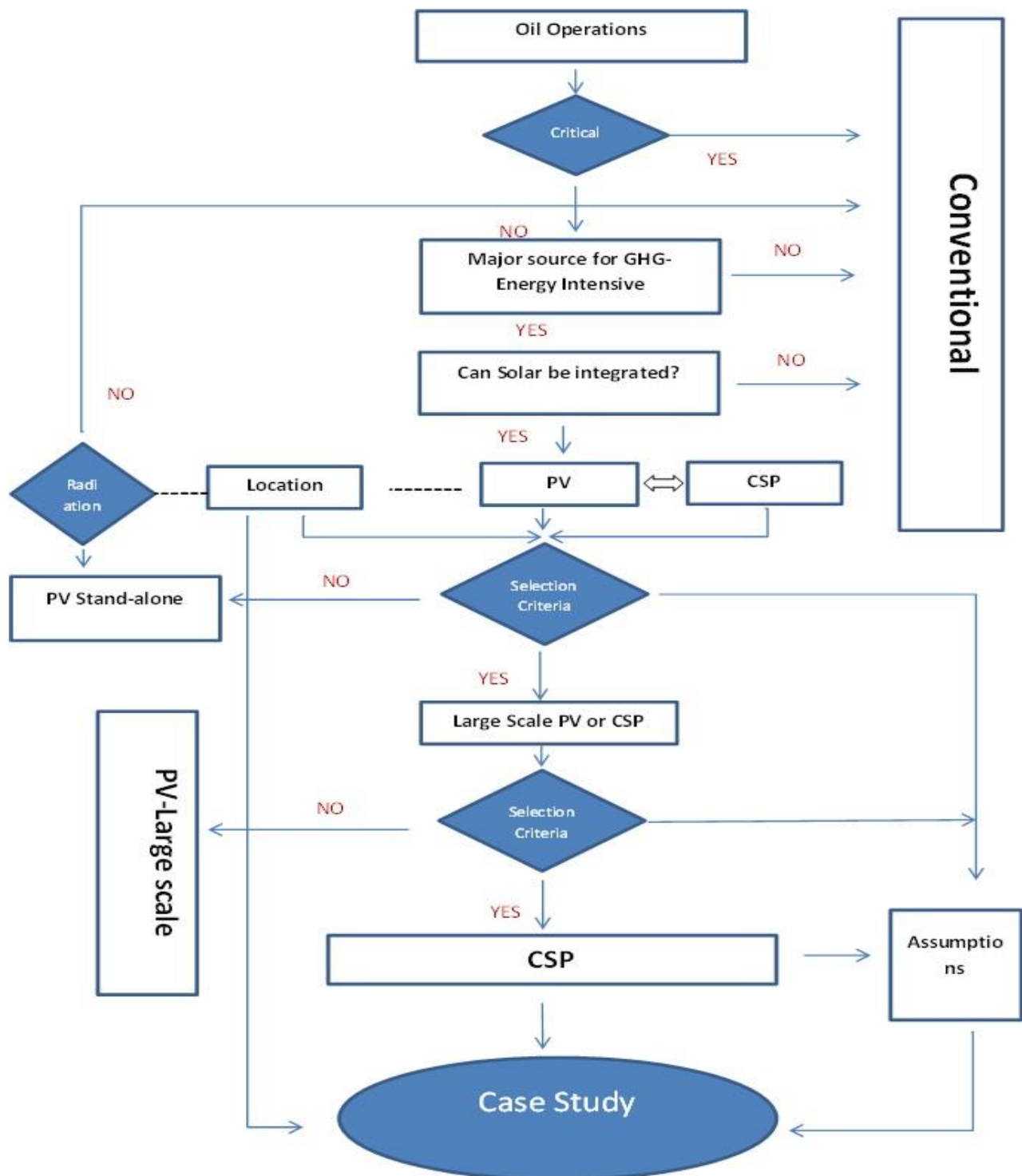

Figure 42 Decision process

6.3 Selection of process and solar technology

The following selection criteria are used to select the process in USOSC and the type of solar technology:

- 1- Major process that consumes a lot of energy: based on this, small applications and individual equipment were eliminated from the possible choices
- 2- Significant reduction of GHG reduction to protect the environment and to help in the financial viability of the solar system investment through carbon credit calculations
- 3- Smooth connection to grid to increase the financial viability

The options meeting the above selection criteria are listed in table 11

6.3.1 Selected process and solar type

Based on the selection analyses shown in table 11, Photovoltaic (PV) standalone systems will not be selected due to the following reasons:

- 1- System simplicity
- 2- Low level of GHG reduction from associated applications
- 3- Constraints related to space (area) available in some USOSC processes for the PV stand-alone system
- 4- Constraints related to storage system (if needed)

Enhanced oil recovery (EOR) and electricity generation using either CSP or large scale PV will be investigated in the case study. The next comparison is between CSP and large scale PV

Table 11 possible options meeting selection criteria

Application	Classification	Emissions	Energy need	Solar Technology	Grid
EOR- steam generation	Major operation Non-critical	Major source	High	CSP PV large scale	YES
RTU's	Regular-Critical	Indirect	Low	Stand-alone PV system Or through electricity coming from CSP steam turbines or large scale PV	NO
Telecommunication	Regular-Critical	Indirect			YES
SCADA					
Flow measurement	Regular-Non critical				
Drilling meters (part of EOR)					
Process control equipment					
Cathodic protection	Major-Critical	Medium			
Lighting		Medium-High	High	Electricity coming from CSP steam turbines or Large scale PV	YES
Heat Supply Water heaters	Major-Non critical	Medium	Medium-High	Electricity coming from CSP steam turbines or large scale PV	YES

				or steam directly from CSP	
--	--	--	--	-------------------------------	--

6.4 CPS vs. large scale PV

The decision to choose CSP or large scale PV for selected USOSC process and application is very critical; the following criteria are used to help in making the selection:

- 1- High power production
- 2- High conversion efficiency
- 3- High rate of return on investment
- 4- Less environmental impacts
- 5- Ease of connection to grid

Table 13 shows the comparison between CSP and large scale PV assuming same power rating and same environment conditions ⁽³⁵⁾ ⁽³⁶⁾ ⁽³⁷⁾

Table 12 CSP vs. large scale PV

	PV Vs. CSP
Produced Power	<ul style="list-style-type: none"> • CSP plant produces more energy than PV plant • CSP has higher conversion efficiency than CSP
Return on investment	<ul style="list-style-type: none"> • CSP has better ROI and shorter payback period • The initial cost to setup CSP plant is higher than PV large scale plat

Land and Topology	<p>This comparison strongly depends on the type of PV and CSP technology used and the plant capacity, for example:</p> <ul style="list-style-type: none"> • 50 MW PV fixed ground type crystalline silicon PV modules need less area than CSP tower plant • A 100 MW CSP trough will require less area than PV large scale plant • CSP needs flat area, while PV can be installed in lands with some slope
O&M Cost	<ul style="list-style-type: none"> • CSP needs higher O&M cost • If proper protection done to the CSP mirrors (protection inside glass houses), CSP O&M will drop significantly and can be lower than PV
Grid connection	<ul style="list-style-type: none"> • CSP can provides predictable energy which is not the case in large scale PV unless extras systems are added (i.e invertor response system) • CSP can support the primary and secondary frequencies control which makes CSP good choice to provide grid with power in steady-state and transitional phases • Storing excess energy generated by CSP is improves the connection with grid more, as loads can supplied at different times to meet the demand
Environment Impact & GHG emissions	<ul style="list-style-type: none"> • CSP generates less emissions than PV large scale • Using storage makes CSP more effective in lowering the generation of emissions from back-up system required to offset interruption

Based on the above criteria, CSP is selected, the next question: what specific type of CSP?

6.5 Selection of CSP type

To answer the question, technical and financial comparisons are done to select the CSP technology

6.5.1 Technical comparison

Table 13 shows technical comparison between the four types of CSP ⁽³⁷⁾

Table 13 Types of CSP

	Advantage	Disadvantage
Trough	<ul style="list-style-type: none"> • High optical efficiency • Simple integration with storage system • Good conversion ratio (~ 16%) 	<ul style="list-style-type: none"> • Need large quantities of for cooling • Need larger land than other types • If dry cooling is used, then initial investment cost will increase by 10% average
Fresnel	<ul style="list-style-type: none"> • Average need for area (land) • Lowest cost • Can produce steam directly without using HTF 	<ul style="list-style-type: none"> • Poor optical efficiency • Poor conversion efficiency (8 - 10) %
Tower	<ul style="list-style-type: none"> • Lowest need for cooling water • Can accommodate different design for storage with different sizes 	<ul style="list-style-type: none"> • Limited expansion possibilities • less standards for system components designs

	<ul style="list-style-type: none"> • Average conversion efficiency (~12%) and can reach up to 20% 	
Dish	<ul style="list-style-type: none"> • doesn't need water for cooling • lowest need for land • High efficiency (20-25) % 	<ul style="list-style-type: none"> • Storage is only possible in big system • High cost

6.5.2 Financial comparison

6.5.2.1 Capital cost

Capital cost can varies based on changes in plant capacity, location and designed life of the plant, however a comparison based on the existing plants value divided by capacity for different types of CSP technologies is shown figure 43 ⁽²⁴⁾ ⁽³⁶⁾

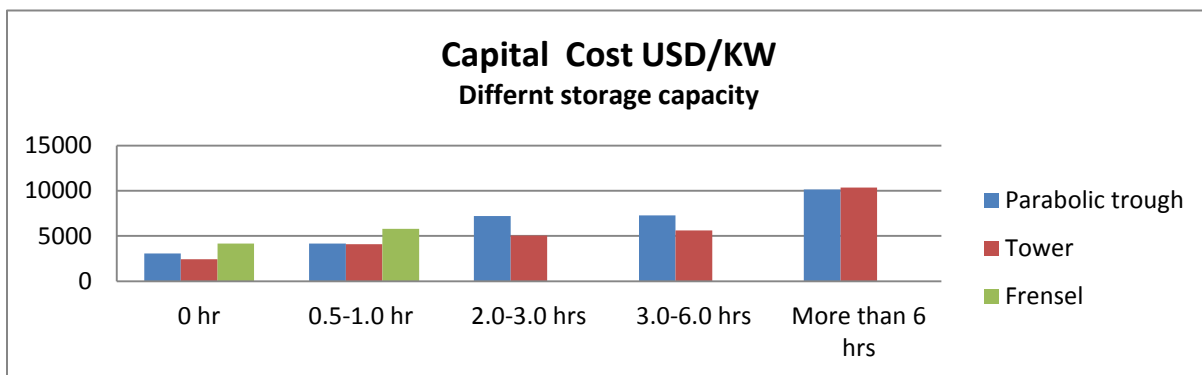

Figure 43 Capital cost for different CSP technologies

6.5.2.2 O&M Cost

O&M cost for the four types is almost similar, figure 44 shows comparasaion between the trough and tower technologies to give example of the differnces . As seen in figure; most of the O&M costs are fixed

(almost 90%) which minimizes the differences in financial comparison ⁽²⁴⁾

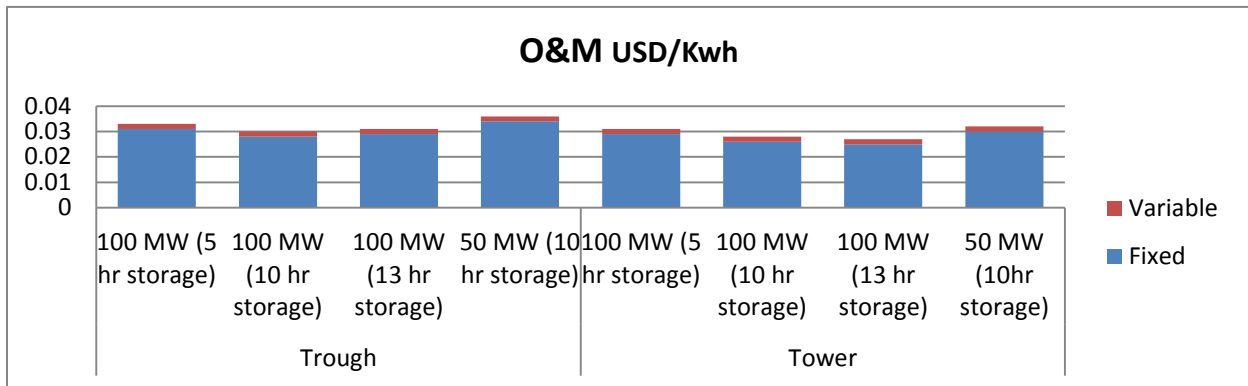

Figure 44 O&M Cost

6.5.2.3 Life cost of energy (LCOE)

LCOE values for CSP technologies starts from 140 USD/MWH and can go up to 360 USD/MWH. LCOE variation strongly depends on location (radiation intensity) and storage. However, the average values for CSP tower and trough commonly used in the industry are the followings ^{(24) (36)}:

- 1- CSP tower range (160-270) USD/MWH
- 2- CSP parabolic trough range (140-300) USD/MWH

6.5.2.4 Selection criteria for the type of CSP

- 1- High optical efficiency
- 2- High conversion ratio
- 3- Possibility of dry cooling
- 4- Storage possibility
- 5- Expansion possibility
- 6- Low LCOE

Based on the above analysis; CSP parabolic trough is selected in this study. The next question: what is the location?

6.6 Location

CSP trough performance is related to the intensity of the direct normal irradiance (DNI) and for any CSP trough project to be profitable; the DNI value must be above 2100 kWh/m²/year⁽³⁸⁾ which is common practice in the solar industry (exceptions might happen, based on strategic decisions by the using country). Based on this, the best places for CSP trough installation are the African deserts, Australia and Middle East as shown in figure 45

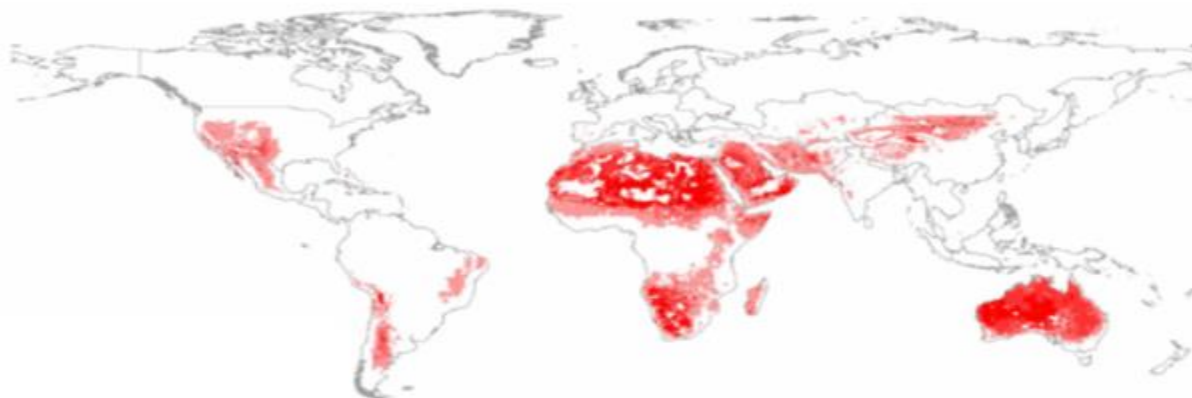

Figure 45 CSP world's best locations

(Source: desert tech website <http://www.desertec.org/global-mission>)

Location affects the financial viability of the project; the higher the radiation intensity, the lower the LCOE. For example, projects in the Middle East-GCC will have lower LCOE compared to the same capacity if installed in south Europe⁽³⁸⁾

6.6.1 Selection criteria for the location

- 1- High DNI levels
- 2- Oil Producing country
- 3- Availability of enough data to support the study
- 4- Availability of supporting legislation to support renewable energy

Based on the above criteria, number of countries can be selected as they all meet the above criteria.

However, Abu Dhabi in UAE is selected for this study

6.7 Assumptions

The above analysis answered the first group of questions (section 6.1) and in order to answer the second group of questions (6.2) and proceed with case study calculations; the following assumptions are made:

- 1- The assumed oil production capacity is 2 million tons of oil and gas per year
- 2- Three scenarios can be used to calculate the GHG emissions (see section 8.6.1)
- 3- The number of equipment emitting GHG by leaking is only as listed in table 14 ⁽⁵⁾
- 4- The only sources for GHG emission are as shown in table 15
- 5- Indirect GHG emissions are not considered (outsourced electricity or construction)
- 6- The CO₂ credit value is 15 USD/tonne CO₂
- 7- Carbon contents in combustion fuel is (87)%
- 8- Gas and diesel are the only types of fuels used in USOSC operations
- 9- The USOSC operations consumes 85000 tons of gas per year used for different purposes including power and steam generation)

- 10- The USOSC operations consumes 300 tons of diesel used in different purposes including trucks and small devices operations
- 11- The annual flared gas quantity in USOSC is (50000) tons
- 12- Oil is transported by land
- 13- 1200 tons of fuel is used every year for land transportation
- 14- Fixed roof is used in storage tanks
- 15- Operating conditions for all the equipment are unchanged
- 16- The capacity of the CSP solar plant is 120 MW
- 17- 60,000 tons diesel/year is needed when the 120 MW solar power plant is operated by diesel
- 18- CSP plant investment increases by 10 % when dry air cooling is used
- 19- 250 million gallons of water will be needed if water cooling system is used in CSP plant
- 20- In EOR, the ratio of steam to recovered is 5 ton/ton
- 21- The efficiency of the steam turbine in EOR operation is 85% ⁽³⁹⁾
- 22- 2000 tons/year equivalent to 100,000 Mcf (based of natural gas density is 0.7 kg/m³) will be needed if gas is the used fuel to generate steam in EOR operations
- 23- Price of natural gas is 4.0 USD/Mcf

Table 14 Number of leaking sources

Equipment	Connections	Valves	Rotating shafts and pressure relief valves
Separator	324	122	18
Scrubber	337	135	24
Heat Exchanger	132	30	15

Equipment	Connections	Valves	Rotating shafts and pressure relief valves
Compressor-single	228	75	42
Pump-Centrifugal	109	41	11
Refrigerator unit	675	225	90
Drier-Molecular	270	90	60
Turbo Expander	60	15	30
Amino system	300	105	38
Glycol Unit	225	75	30

Table 15 Assumed sources of GHG

Source		Equipment
Combustion	Stationary	<ul style="list-style-type: none"> Boilers/steam generators , Dehydrator re-boilers , Heaters/treaters Turbine electric generators, Internal combustion (IC) engine generators , Fire pumps , Reciprocating compressor drivers, , Turbine/centrifugal compressors Well driller, Flares , Incinerators
	Mobile	Mobile drilling equipment , Other company vehicles , Site preparation, construction and excavation

Source		Equipment
Vented	Process	Dehydration processes , Dehydrator pumps, Gas sweetening processes
	Other	<ul style="list-style-type: none"> • Tanks, drilling operations and Well testing, • injection pumps and Gas test devies
	Maintenance /scheduled	Mud degassing , well casing, Compressor blow downs, Compressor starts, Vessel blow down Collection pipeline blow downs , Well discharge operations
	Non routine	Emergency shutdown (ESD)/ emergency safety blow down (ESB), Pressure relief valves (PRVs), Fire Suppression
Indirect		Electricity imports , Process heat/steam imports , Cogeneration
Fugitive		Equipment component leaks , Wastewater treatment , Air Conditioning

6.8 Calculations

This section covers the calculations of the GHG emissions with and without the integration of solar energy and calculates the saved CO₂ quantities

6.8.1 Methodology

Due to the possible variance in GHG calculations, three scenarios based on the oil industry exploration and production forum's five tier methodology ⁽⁴⁰⁾ are used to calculate the GHG emissions using standard values for emission factors in order to check the degree of calculations accuracy, the scenarios are:

- 1- Scenario one : consider the production volume as base of calculations; this is preliminary estimate that might give higher results than actual, it is used here to set the highest emissions values and compare the variance with the results obtained from the other scenarios
- 2- Scenario two : consider the amount of fuel consumed and volume of gas used for venting and flaring
- 3- Scenario three: consider the type of equipment and the amount of emissions from each equipment

6.8.2 Emission factors

The emission factors for each of the above scenarios are obtained from the oil industry exploration and production international forum report ⁽⁴⁰⁾ that analyzed many operational facilities across of the world. The amount of GHG can be calculated when the measured parameter multiplied by the emissions factor

6.8.3 Scenario One

The emission factors and the amounts of GHG emissions are shown in Table 16*

Table 16 Scenario one emission factors and GHG quantities

Gas	Factor	Amount (ton/year)
CO ₂	1.92 x10 ⁻¹	384,000
CO	2.5 x10 ⁻⁴	500
N0x	6.0 x10 ⁻⁴	1200
N ₂ O	2.4 x10 ⁻⁶	4.8
SO ₂	2.1 x10 ⁻⁵	42
CH ₄	2.6 x10 ⁻³	5200
VOC	1.9 x10 ⁻³	3800

Gas	Factor	Amount (ton/year)
Total		394,746.8

* Notes for scenarios one:

- The CO₂ emission factor for processing gas alone varies based on the molecular weight and ranges from (2.81-3.81) tone CO₂ for one ton of gas, the emission factor shown in the table is for combined oil and gas
- The estimate using scenario one generally gives higher emission amounts than actual \

6.8.4 Scenario Two

Scenario two takes fuel consumption into consideration; therefore, it is important to use emission factors based on the type of the used fuel. In this study, and as per the assumption listed in section 6.7, only gas and diesel are considered the main fuels used in USOSC operations,.

Table 17 shows the emission factors based on gas and diesel used for combustion purposes in addition to the emission factors for flared gas

Table 17 Emission factors for gas and diesel combustion

Gas	Combustion Fuel		Flared Gas
	Gas factor (tons emissions per tons of burned gas)	Diesel factor (tons emissions per tons of burned diesel)	Gas factor (tons emissions per tons of gas flared)
CO ₂	2.75	3.2	2.61

Gas	Combustion Fuel		Flared Gas
	Gas factor (tons emissions per tons of burned gas)	Diesel factor (tons emissions per tons of burned diesel)	Gas factor (tons emissions per tons of gas flared)
CO	2.5×10^{-3}	1.9×10^{-2}	8.7×10^{-3}
N0x	6.7×10^{-3}	7.0×10^{-2}	1.5×10^{-3}
N ₂ O	2.2×10^{-4}	2.2×10^{-4}	8.1×10^{-5}
SO ₂	1.2×10^{-5}	8.0×10^{-3}	8.0×10^{-3}
CH ₄	4.3×10^{-4}	1.4×10^{-4}	1.3×10^{-5}
VOC	5.1×10^{-5}	1.9×10^{-3}	1.5×10^{-3}

6.8.4.1 Calculations of GHG using scenario two

For a production facility producing 2 million tons/year of oil and gas and based on the assumptions used in this study case, 85000 tons of gas and 300 tons of diesels in addition to 50,000 tons of flared gas are used as the base of calculations shown in table 18 below

Table 18 Scenario two GHG calculations

		Gas-Power Generation	Diesel-Power Generation	Gas-Flared	Total
Quantity tons/year		85000	300	50000	
CO₂	Factor	2.75	3.2	2.61	
	Quantity	229500	960	130500	360,960
CO	Factor	0.0027	0.019	0.0087	
	Quantity	229.5	5.7	435	670.2
N0_x	Factor	0.0067	0.07	0.0015	
	Quantity	5695	21	75	5791
N₂O	Factor	0.00022	0.00022	.000081	
	Quantity	18.7	0.066	4.05	22.816
SO₂	Factor	0.000013	0.008	0.000013	
	Quantity	1.1	2.4	0.65	4.15
CH₄	Factor	0.00042	0.00014	0.035	
	Quantity	35.7	0.042	1750	1785.74
VOC	Factor	0.000051	0.0019	0.015	
	Quantity	4.34	0.57	750	754.91
Total					369,988.6

6.8.5 Scenario Three

In this scenario, the type of equipment operated by gas or diesel plays a role in the calculations of GHG emission, the transportation and storage leaks are also be considered in the calculations.

Tables 19 shows the emission factors of different equipment operated by gas and diesel, table 20 shows the emission factors for combustion fuel used in transportation and table 21 shows the emission factors from storage operations

Table 19 Emissions factors for equipment operated by gas and diesel (ton emission/ton of used fuel)

Type	Turbines		Engines		Heaters	
	Gas	Diesel	Gas	Diesel	Gas	Diesel
CO ₂	2.75	3.2	2.75	3.2	2.75	3.2
CO	2.7 X10 ⁻³	2.1 X 10 ⁻³	9.6 X10 ⁻³	1.9 X 10 ⁻³	8.0 X10 ⁻⁴	7.0 X 10 ⁻⁴
N0x	6.7X10 ⁻³	9.4 X 10 ⁻³	7.6 X10 ⁻²	7.0 X 10 ⁻²	3.1X10 ⁻³	2.8 X 10 ⁻³
N ₂ O	2.2 X10 ⁻⁴	2.2 X 10 ⁻⁴	2.2 X10 ⁻⁴	2.2 X 10 ⁻³	2.2 X10 ⁻⁴	2.2 X 10 ⁻³
SO ₂	2.56 X10 ⁻⁶	8 X 10 ⁻³	2.56 X10 ⁻⁶	8 X 10 ⁻³	2.56 X10 ⁻⁶	8 X 10 ⁻³
CH ₄	4.2 X10 ⁻⁴	8 X 10 ⁻⁵	2.8 X10 ⁻²	1.4 X 10 ⁻⁴	7.0 X10 ⁻⁵	7.8 X 10 ⁻⁶
VOC	5.1 X10 ⁻⁵	7.0 X 10 ⁻⁴	3.0 X10 ⁻³	1.9 X 10 ⁻³	6.2 X10 ⁻⁴	2.8 X 10 ⁻⁵

Table 20 Emissions factors for land transportation based on fuel combustion (ton emission/ton of fuel)

Type	Factor	Type	Factor
CO ₂	3.2	SO ₂	8 X10 ⁻³
CO	2.7 X10 ⁻²	CH ₄	2.3 X10 ⁻⁴
N0x	3.8 X10 ⁻²	VOC	5.4 X10 ⁻³
N ₂ O	2.2 X10 ⁻⁴		

Table 21 Emission factor for storage tanks (ton emissions/ton through-put)

Type	Fixed Roof	Floating roof/internal	Floating roof/external
CH ₄	2.0 X10 ⁻⁷	4.8 X10 ⁻⁸	1.5 X 10 ⁻⁷
VOC	1.12 X10 ⁻⁴	2.0 X10 ⁻⁷	8.5 X 10 ⁻⁷

6.8.5.1 Calculations of GHG using scenario 3

The calculations of GHG emissions in scenario three considered 1200 tons of fuel for land transportation and fixed roof for storage tanks in addition the same assumptions used in scenario two calculations. Table 22 shows the outcome of scenario three calculations

Table 22 Scenario three GHG emissions (ton emissions per year)

		Turbine-Gas	Turbine-Diesel	Gas-Flared	Land Transport	Storage/Fixed roof	Total
Quantity tons/year		85000	300	50000	1200		
CO₂	Factor	2.75	3.2	2.61	3.2		
	Quantity	229500	960	130500	3840		364,800
CO	Factor	0.0027	0.019	0.0087	0.0052		
	Quantity	229.5	5.7	435	6.24		676.44
N₂O	Factor	0.0067	0.07	0.0015	0.0125		
	Quantity	5695	21	75	15		5806
N₂O	Factor	0.00022	0.00022	.000081	0.00022		

		Turbine- Gas	Turbine- Diesel	Gas- Flared	Land Transport	Storage/ Fixed roof	Total
	Quantity	18.7	0.066	4.05	0.264		23.15
SO₂	Factor	0.000013	0.008	0.000013	0.008		
	Quantity	1.1	2.4	0.65	9.6		13.75
CH₄	Factor	0.00042	0.00014	0.035	0.0087	0.0000002	
	Quantity	35.7	0.042	1750	0.1	0.4	1786.24
VOC	Factor	0.000051	0.0019	0.015	0.0008	0.000112	
	Quantity	4.34	0.57	750	0.96	224	979.87
GHG Total							374,085.45

6.8.6 Summary of the results of the three scenarios

- 1- Carbon dioxide (CO₂) is the main gas in GHG emission in USOSC operations (around 98%)
- 2- The values of CO₂ given by scenario two and scenario three are close to each other (360,960 and 364,800 tons CO₂/year respectively) while the first scenario gave higher results (384,000)
- 3- Because the first scenario gave higher values than actual, the values of the second and the third scenarios will be used in the calculations of the saved CO₂ when solar energy is integrated

6.9 Integration of solar

Concentrated solar power (CSP) parabolic trough technology to generate steam for EOR and electricity generation using steam turbine is assumed in this study, the proposed capacity is 120 MW

The generated electricity can be connected to the internal power distribution network to feed USOSC operations with the required electricity or can be connected with the main electricity grid, the later one needs strategic decision and defined frame work for electricity supply

The specifications of the proposed CSP trough system ⁽⁴¹⁾ ⁽⁴²⁾ are shown in table 23

Table 23 CSP system specifications

Capacity	120 MW	Length of solar aperture	100
Number of mirrors	300000	Receiver radius	5 cm
Collector loops:	200	Optical-efficiency percentage	80%
Collector assemblies/loop	4	Receiver-absorptivity percentage	95%
Assembly units	800	Reflection ratio	95%
Required land area	3 km ²	Emittance percentage	20 %
Width of solar aperture	6 m		

6.10 Radiation level in Abu Dhabi

The solar radiation levels that can be used in different months/seasons in Abu Dhabi is shown in table 24 and the hourly distribution is shown in figure 46 ⁽⁴¹⁾ ⁽⁴³⁾

Table 24 Average useful solar energy/month (kWh/m2.month)

Month	Useful quantity	Month	Useful quantity	Month	Useful quantity
January	77.28	May	175.77	September	143.19
February	105.34	June	173.01	October	121.18
March	108.93	July	157.33	November	85.71
April	130.62	August	161.20	December	68.54

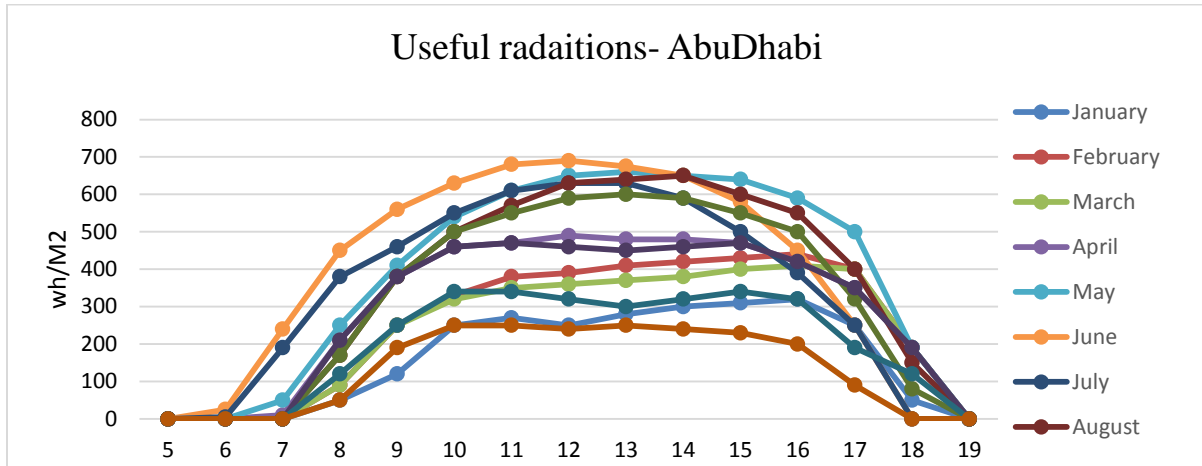

Figure 46 Useful hourly radiations AD (Wh/m²)

Source of Data: (Tora, *Integration and optimization of tri-generation system with solar energy, biofuels, process heat and fossil fuels*, Texas A&M University, 2010)

6.11 Electricity generation-steam turbines

The mirrors will concentrate the sun radiations on a central tube with heat transfer fluid flowing inside raising its temperature to around 350 °C, when the sun radiation can't provide enough heat to the heat transfer fluid (HTF); a gas or diesel operated heater will be used to provide the needed heat to raise the temperature of the oil to the desired temperature. The oil is then directed to a heat exchanger between oil and water to convert the water to steam which is then sent to a gas or diesel powered booster heater to raise its temperature to around 550 °C (e.g. Masdar UAE ⁽⁴²⁾ installation used 540 °C as output temperature while Siemens SST 700 Steam turbine with 175 MW capacity needs 400 C input temp and 100 bar pressure ⁽⁴⁴⁾). The super-heated steam is fed to the steam turbine to generate electricity which can feed the USOSC internal distribution network or can be connected to the external electricity grid. The steam leaving the turbine will go through condensation system using water or dry air for cooling. Dry air cooling is 10 % (on average) higher in cost than water cooling systems, however, dry cooling saves large

amounts of water used in water cooling systems. The heat transfer fluid leaving the heat exchanger will have lower temperature and will be re-circulated again in the system, see figure 47

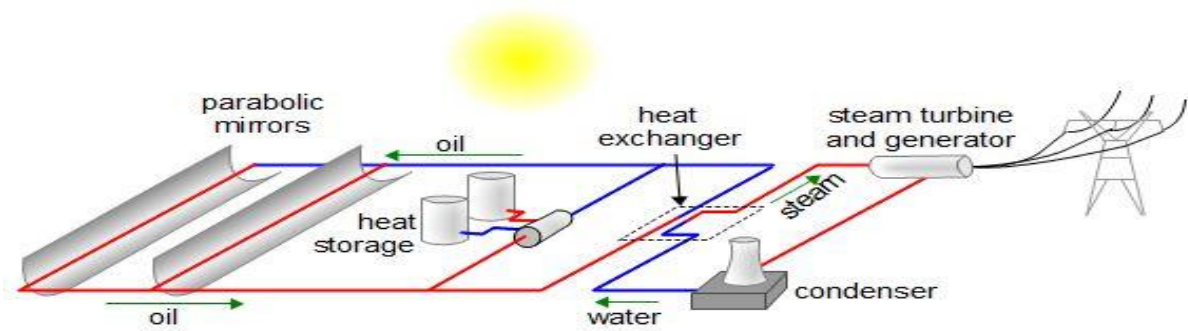

Figure 47 Solar-steam electricity generation (Source rim star organization website, [www. rimstar](http://www.rimstar.com))

6.11.1 Results

Based on the assumptions in section 6.1 and using dry air for cooling give the following results:

- 1- A total of 192,000 tons CO₂ will be saved every year if solar energy is the only source to provide the full power requirement.
- 2- Considering 15 USD/tonne CO₂ equivalent as the value of GHG credit, a total of 2.8 million USD every year can be added to the economic analysis of the investment
- 3- Air dry cooling saves 250 million gallons of water every year

6.12 Solar-steam for EOR

Using solar energy to produce steam for enhanced oil recovery purposes is more applicable to USOSC operations as thermal enhanced oil recovery (TEOR) is now used in many oil production facilities around the world. The process of steam production can be similar to the one described in the previous section using heat transfer fluid or by direct steam generation (DSG) where mirrors will concentrate the sun radiations to heat water flowing inside the circulation pipes to generate steam which can be sent directly to EOR operations or can be sent to the booster heater to generate superheated steam before it is directed

to EOR operations and no heat exchanger will be needed in this case. The mirrors of the CSP system will be installed inside a protection glass house as seen in figure 48 to protect it from the harsh weather conditions including dust and high humidity in order to minimize the O&M cost



Figure 48 CSP glasshouse (Source: glass point Co. website [glasspoint](http://glasspoint.com))

Excess solar energy obtained during peak time can be stored using molten salt storage technique and because of the high solar radiation intensity in Abu Dhabi; a high storage capability is needed to store energy enough to continue feeding operations for (6-7) hours after sunset in the summer and (2-4) hours in winter, see figure 49

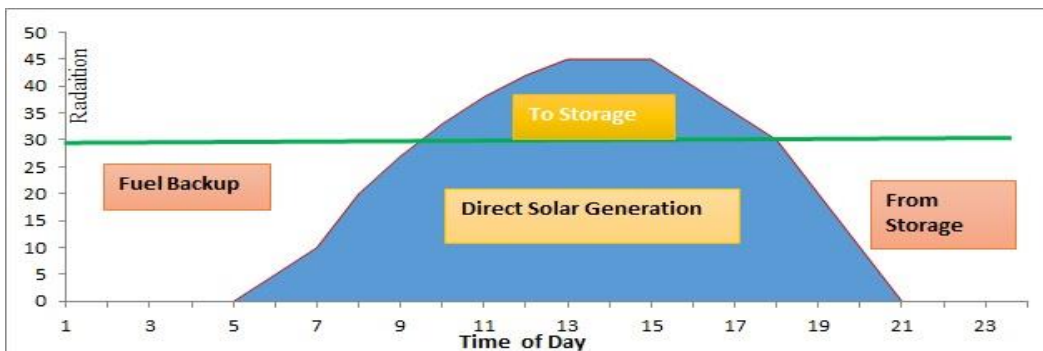

Figure 49 Solar storage supply

In order to maintain continuous steam flow and to overcome the day-night and seasonal cycles, a gas or diesel booster will be part of the process to produce steam when solar energy can't provide enough steam. As seen in figure 46; the sun will provide useful power for an average of (12-13) hours in summer and

storage will provide power for (6-7) hours which means that gas will be used for (4-6) hours while in winter; the sun will provide useful radiations for (9-10) hours, storage can continue to provide power for another (2-3) hours and gas will be needed for (11-13) hours every day

6.12.1 Results

6.12.1.1 Reduction in gas combustion and saved CO₂

Table 25 shows the reduction in gas combustion and saved CO₂ quantities with three different storage capacity, the calculations are based on the assumptions made in section 6.1 (gas needed in EOR operation is 8500 tons/year, steam/oil ratio is 5 ton/ton and the steam turbine efficiency is 85%). As seen in the results; the proposed storage of (6-7) hours gives the best results

Table 25 Reduction in gas combustion and saved CO₂

Storage (hours)	Reduction in gas (%)		Saved CO ₂	
	Summer	Winter	Summer	Winter
0	50	40	11,687	9,350
2-3	60	50	13,872	11,687
6-7	80	NA	18,700	NA

6.12.1.2 Financial impacts

The analysis of the investment of CSP plant is out of the scope of this study; however, table 26 lists some financial advantages from the saved CO₂ and gas used in steam turbines. The calculations are based on the assumptions listed in section 6.1 (amount of natural gas used in EOR is 2000 tons/year equivalent to 100,000 Mcf, natural gas density is 0.7 kg/m³ and price of natural gas is 4.0 USD/Mcf, CO₂ credit value is 15 USD/ton CO₂)

Table 26 Financial advantages

Storage (hours)	Value of Saved CO ₂ USD/year		Value of Saved Gas USD/year	
	Summer	Winter	Summer	Winter
0	17,305	140,250	200,000	160,000
2-3	208,080	175,305	240,000	20,000
6-7	280,500	NA	320,000	NA

6.12.1.3 Reservoir life time

The financial viability of EOR operations is related to the ration of the injected steam to recovered oil, the assumed ration in this study is 5, but this ratio will decrease with time as the reservoir age increases. If the cost of recovery (in which gas cost is included) is higher than the cost of recovered oil, then EOR will not be profitable anymore and operations will stop. Using solar steam in EOR will reduce the cost input of gas into the gas recovery overall cost which will increase the life time of the reservoir (assuming that investment on solar is recovered during the life time of the reservoir)

6.13 System challenges

The main systems changes include the followings:

6.13.1.1 Thermal cycles

The day-night and seasonal cycles are considered as major challenge, however; the high radiation levels in Abu Dhabi and the high storage system can overcome this challenge

6.13.1.2 Reflectivity

Although, the system is protected from dust inside the glass house, but it is important to keep monitoring the reflectivity as it can be affected by dust, therefore, it is important to keep washing the mirrors on regular basis

6.13.1.3 Collection/Transmittance

- Design: because the system components are “in series” operation; a defect in one of the components can lead to partial failure in the process of collecting or transmitting the heat, therefore, it is important to ensure that all system components are designed to operate under harsh desert conditions. Good design and performance will also minimize the O&M costs
- Operational failures: like failure of heat collecting system due to losing vacuum or glass breakage, these can be avoided by regular inspection and preventive maintenance planning

6.13.1.4 Land

The proposed installation needs large area of land for the solar field and supporting operations

6.13.1.5 Water availability

Using dry air cooling will overcome this challenge

6.13.1.6 Connection with grid

Legislation and frame work of supply supported by feed-in tariff are important pre-requests to connect the proposed solar plant to the external electricity network

6.14 Summary of results

Table 27 Summary of results

Area	Result
Production capacity	2 M tons/year oil and gas
Location	UAE-Abu Dhabi
Solar technology	CSP trough for steam generation Options: Heat transfer fluid, Heat storage, Direct steam generation , Heat exchanger
Capacity (if electricity)	120 MW
Applications	<ul style="list-style-type: none"> • Steam Turbine • Enhanced Oil Recovery (Excess steam from EOR can go to steam turbines for electricity generation and connection with grid)
CO ₂ reduction	<ul style="list-style-type: none"> • Electricity generation: (192,000) tons/year if full capacity used • EOR : (11, 678.5- 18, 700) ton CO₂/year • Season and storage affect the results
Gas reduction	<ul style="list-style-type: none"> • (25-80) % based on season and storage capacity
Water reduction	Air dry cooling saves 250 million gallons of water every year

Financial advantages	<ul style="list-style-type: none"> • Electricity Generation: 2.8 million USD/year • EOR: (300,000-600,000) USD/year
Connection to Grid	Viable option- Policy/regulations needed
Challenges	Components Quality/Land

6.15 Conclusion

- USOSC operations are energy intensive and generate significant amounts of GHG
- The majority of GHG emissions is carbon dioxide CO₂ (98%)
- Solar energy is the best source of renewable energy to be integrated into oil and gas industry
- Integration of solar energy into oil and gas upstream operations is technically possible
- CSP trough technology supported by good storage system is good example of solar integration into USOSC operations for steam generation purposes
- Steam EOR and electricity generation using steam turbines are suitable applications for solar energy integration
- Significant amounts of CO₂ emissions, gas combustion and cooling water can be saved through the integration of solar energy
- Solar integration has financial advantages on the oil operations and can extend the life of the oil reservoir
- Number of challenges facing solar energy integration need to be addressed including technical, economical and institutional

References

- 1- Havard Devold, *An Introduction To Oil And Gas Production*, Edition 2- ABB Oil And Gas 2009
- 2- US Energy Information Administration, *International Energy Outlook DOE/EIA-0484*, EIA July 2013
- 3- Angela Zahniser, *Characterization Of Greenhouse Gas Emissions Involved In Oil And Gas Exploration And Production Operations*, California Air Resources Board, 2007
- 4- American Petroleum Institute, *Compendium Of Greenhouse Gas Emissions Methodologies For The Oil And Gas Industry*, API -August 2009
- 5- Canadian Association Of Petroleum Producers (CAPP), *Calculating Greenhouse Gas Emissions*, , Publication Number 2003-03, CAPP April 2003
- 6- HIS CERA, *Oil Sands-Greenhouse Gases And US Oil Supply, Special Report: Getting The Numbers Right*, CERA 2012
- 7- IHS CERA, *Major Sources Of US Oil Supply: The Challenge Of Comparisons*, CERA 2011
- 8- Keystone XL Project, *Life Cycle Greenhouse Gas Emissions Of Petroleum Products From Oil Sands Crudes Compared With Reference Crudes Appendix W*, Keystone March 2013
- 9- CAPP, Technical Report; *National Inventory Of Greenhouse Gas (GHG)- Criteria Air Contaminant (CAC) And Hydrogen Sulphide (H₂S) Emissions By The Upstream Oil And Gas Industry Volume 1*, CAPP September 2004
- 10- EIA-*Monthly Energy Review; U.S. Energy Information Administration Office Of Energy Statistics* U.S. Department Of Energy, November 2013
- 11- International Energy Agency (IEA),*Hydropower Report*
[Http://Www.Iea.Org/Topics/Hydropower/](http://www.iea.org/topics/hydropower/) , IEA-2013

- 12- Monique Hoogwijk, *The Global And Regional Potential Of Renewable Energy*, University Of Utrecht ,2004
- 13- Govinda R, Timilisin, *A Review Of Solar Energy Markets, Economics And Policies*, Development Research Group, Environment And Energy Team- World Bank, October 2011
- 14- Renewable Energy Policy Network, *Renewables Global Status Report* , RENA21-2013
- 15- Eric Brown, *An Introduction To Solar Energy*,
[Http://Www.Ccs.Neu.Edu/Home/Feneric/Solar.Html](http://www.ccs.neu.edu/home/feneric/solar.html) North Eastern University, 1988
- 16- Arvizu, D., *Renewable Energy Sources And Climate Change Mitigation -Direct Solar Energy (Chapter3)*, Cambridge University Press, 2012
- 17- Moore, Taylor; *Opening The Door For Utility Photovoltaic*; EPRI Journal, January 2007
- 18- Olav Hohmeyer, Tom Trittin, *The Intergovernmental Panel On Climate Change (IPCC), IPCC Scoping Meeting On Renewable Energy Sources Ii*, World Meteorological Organization (WMO) And The United Nations Environment Program (UNEP) Lübeck, Germany, 20 – 25 January,2008
- 19- Hans Muller Steinhagen, Franz Trieb, *Concentrating Solar Power; A Review Of The Technology*, Institute Of Technical Thermodynamics, German Aerospace Center,2006
- 20- Peter Meisen- Oliver Pochert, *A Study Of Very Large Solar Desert Systems With The Requirements And Benefits To Those Nations Having High Solar Irradiation Potential*, Global Energy Network Institute (GENI)- July 2006
- 21- European Photovoltaic Industry Association (EPIA), *Global Market Outlook For Photovoltaic*, EPIA 2011
- 22- Kevin Ummel, *Concentrating Solar Power In China And India: A Spatial Analysis Of Technical Potential And The Cost Of Deployment*, Center For Global Development [Cgdev](http://www.cgdev.org) July 2010
- 23- Renewable Energy Technology, *Cost Analysis Series Volume 1; Concentrating Solar Power*, IRENA 2012

- 24- Earth Observatory, <Http://Earthobservatory.Nasa.Gov/Features/Energybalance/Page2.Php>, NASA Website, 2013
- 25- Lazard, *Levelized Cost Of Energy Analysis – Version 5.0*, LAZARD, June 2011
- 26- International Energy Agency (IEA), *Projected Cost Of Generating Electricity*, IEA 2010
- 27- Emerging Energy, *Global Concentrated Solar Power Markets And Strategies: 2009-2020*, Emerging Energy [Emerging-Energy](#) April 2009
- 28- EPIA, Greenpeace, *Solar Photovoltaic: Powering The World, Solar Generation Volume 6*- EPIA 2011
- 29- European Renewable Energy Council & Greenpeace International, *Energy Revolution; A Sustainable World Energy Outlook-GPI REF JN 035*. Greenpeace International And EREC January 2007
- 30- Cédric Philibert, *International Technology Collaboration And Climate Change Mitigation Case Study 1: Concentrating Solar Power Technologies* -Eia 2004
- 31- Adel Gastli, *Potential of Solar Energy Applications In Oman Oil, The 20th Joint GCC-Japanese Environment Symposium NOV. 2011* Abu Dhabi, Sultan Qabus University 2011
- 32- A.P.G. Van Heel, *The Impact of Daily And Seasonal Cycles In Solar Generated Steam For Oil Recovery, Report Number 129225*, SPE International 2010
- 33- Coalinga Project Facts, *Concentrating Solar Power Project*, Bright Source Company [Www. Brightsourceenergy.Com](http://www.brightsourceenergy.com), 2013
- 34- Silvano Vergura, *Technical-Financial Comparison Between A PV Plant And A CSP Plant Volume 6*, Revista Eletrônica Sistemas & Gestão 2011
- 35- Martino Bosatra Federico Fazi, *Utility Scale PV And CSP Solar Power Plants Performance: Impact on The Territory and Interaction With The Grid*, Foster Wheeler Italian 2010

- 36- SBC Energy Institute, *Leading The Energy Transition Fact Book -Concentrating Solar Power*, Schlumberger- June 2013
- 37- European Academic Science Advisory Council (EASAC), *Concentrating Solar Power: its Potential Contribution to a Sustainable Energy Future Policy Report 16*, EASAC- November 2011
- 38- Adam R. Brandt and Stefan Unnasch, *Energy Intensity and Greenhouse Gas Emissions from Thermal Enhanced Oil Recovery*, Energy Fuels 2010
- 39- Andy Shah & Pam Pop, *Methods For Estimating Atmospheric Emissions From Exploration and Production Operations*, The Oil Industry Exploration and Production Forum 1994
- 40- Eman Tora, *Integration and Optimization of Tri-Generation System With Solar Energy, Biofuels, Process Heat And Fossil Fuels*, Texas A&M University, 2010
- 41- Shams -Masdar., [Shamspower](#) , Shams Power Co. 2013
- 42- Energy Efficiency, [ERER energy, US Department Of Energy, 2013](#)
- 43- Energy Sector- Oil And Gas Division, *Steam Turbines For CSP Plants*, Siemens AG 2010, Siemens AG 2010
- 44- International Energy Agency (IEA), *Technology Road Map-Concentrating Solar Power CSP*, IEA 2013
- 45- The Free Encyclopedia, Wikipedia, [Wikipedia](#)
- 46- Wisner, R., G. Barbose, And C. Peterman (2009). *Tracking The Sun: The Installed Cost Of Photovoltaics In The U.S. From 1998-2007*. Lawrence Berkeley National Laboratory, Berkeley, CA, USA
- 47- World Bank Global Environment Facility Program (2006). *Assessment Of The World Bank/GEF Strategy For The Market Development Of Concentrating SolarThermal Power*. The International Bank For Reconstruction And Development, TheWorld Bank, Washington, DC, USA

48- Gerdes, K. J.; Skone, T. J. *An Evaluation Of the Extraction- Transport and Refining of Imported Crude Oils and The Impact On Life Cycle Greenhouse Gas Emissions; Office Of Systems, Analysis and Planning*, National Energy Technology Laboratory (NETL)- Pittsburgh, , March 2009