

Grey Numbers in Multiple Criteria Decision Analysis and Conflict Resolution

by

Hanbin Kuang

A thesis
presented to the University of Waterloo
in fulfillment of the
thesis requirement for the degree of
Doctor of Philosophy
in
Systems Design Engineering

Waterloo, Ontario, Canada, 2014

© Hanbin Kuang 2014

Author's Declaration

I hereby declare that I am the sole author of this thesis. This is a true copy of the thesis, including any required final revisions, as accepted by my examiners.

I understand that my thesis may be made electronically available to the public.

Abstract

Definitions of grey numbers are adapted for incorporation into Multiple Criteria Decision Analysis (MCDA) and the Graph Model for Conflict Resolution (GMCR) in order to capture uncertainty in decision making. The main objective is to design improved methods for dealing with decision problems under uncertainty, characterized by limited input data and uncertain preferences of decision makers (DMs). A literature review is carried out in order to understand the problems of representing uncertainty using grey numbers within two key decision making contexts: comparing alternative solutions within an MCDA framework, and deciding upon meaningful courses of action by DMs involved in a conflict. Then two methodologies that rely on grey numbers to represent uncertain information are provided, and relevant definitions, procedures, and solution concepts are presented.

A new approach to handling uncertainty in MCDA using grey numbers is proposed. The grey-based PROMETHEE II methodology is designed to represent and analyze multicriteria decision problems under uncertainty. The basic structure of a grey decision system is developed, including definitions, notation, and detailed calculation procedures. By integrating continuous grey numbers with linguistic expressions, each DM's uncertain preference can be expressed according to multiple criteria. The new methodology takes account of both quantitative and qualitative data, first aggregating the DMs' judgements on the performance of alternatives according to each criterion, and then integrating the criteria in order to determine the relative preference of any two alternatives. These preferences are then incorporated into the PROMETHEE II methodology to generate a complete ranking of alternatives. The procedure is illustrated using a case study in which source water protection strategies are ranked for the Region of Waterloo, Ontario, Canada.

To capture uncertainty in preferences, definitions based on grey numbers are incorporated into GMCR, a realistic and flexible methodology to model and analyze strategic conflicts. A general grey number, consisting of either discrete real numbers or intervals of real numbers, or combinations of them, can represent the preferences of DMs in a very general way. In analyzing a strategic conflict, the relative preference of each DM with respect to feasible states is required before a stability analysis can be carried out. However, because of incomplete information regarding many conflict situations, cognitive limitations

of DMs, the interplay of stakeholders and the complexity of disputes in reality, it is hard to capture accurate preferences of all DMs across all possible scenarios, or states. Here, a grey-based preference structure is developed and integrated into GMCR. Utilizing a number of grey-based concepts, stability definition describing human behaviour under conflict in the face of uncertain preference are introduced for a 2-DM conflict model. This Grey-based GMCR is then applied to a generic sustainable development conflict with uncertain preferences in order to demonstrate how it can be conveniently utilized in practice.

Then the definition of grey preference is incorporated into GMCR in a multiple-DM context in order to model and represent uncertain human behaviour in a more complex strategic conflict. When more than two DMs are involved, coordinated moves against a focal DM need to be taken into account when calculating stable states. In this research, a preference structure based on grey numbers is extended to represent multiple DMs' uncertain preferences for which there can be two or more DMs. Then four kinds of grey stabilities (grey Nash stability, grey general metarationality, grey symmetric metarationality, and grey sequential stability) and corresponding equilibria are defined for a grey-based conflict model with multiple DMs. The feasibility of this methodology is verified through a case study of a brownfield redevelopment conflict in Kitchener, Ontario, Canada.

Acknowledgements

I would like to express my sincere gratitude to my supervisors, Professor Keith W. Hipel and Professor D. Marc Kilgour, for their inspiration, encouragement, guidance and friendship throughout my PhD program and the completion of this research. It is my great honour and distinct pleasure to express my appreciation for their support.

I wish to thank my external examiner, Dr. Adiel Teixeira de Almeida of the Universidade Federal de Pernambuco in Brazil, and the other committee members from the University of Waterloo, consisting of Dr. Mahesh Pandey of the Department of Civil and Environmental Engineering, as well as Dr. Jonathan Histon and Dr. John Zelek of the Department of Systems Design Engineering, for carefully reading my thesis and providing helpful suggestions for improving it.

I wish to extend my gratitude to the secretarial and technical staff of the Department of Systems Design Engineering for their professional service and support. I am especially thankful for the assistance of Ms. Vicky Lawrence, Ms. Colleen Richardson, and Ms. Angie Muir. I also want to acknowledge the China Scholarship Council (NSCIS No 2010683003) for the financial support during my PhD. study, and the education office of the Consulate General of the People's Republic of China in Toronto for their consulting services. I really appreciate the help from Ms. Min Chen.

I am most grateful to my friend and colleague, Dr. M. Abul Bashar, for his valuable suggestions on refining various technical parts in my thesis. My appreciation also goes to my friends for their companionship and support throughout the course of my studies in Canada.

In addition, I express my sincere appreciation to Mrs. Joan Kilgour, whose tutorials helped me to improve my English pronunciation, writing, and grammar. Her kind and

insightful suggestions upgraded the quality of my work. I would also like to thank Mr. Conrad Hipel for editing some my research papers.

I cannot end without thanking my parents, Mr. Baohe Kuang and Ms. Suqin Han, my grandparents, Mr. Yulin Han and Ms. Guilan Zheng, and my fiancée, Ms. Chenxu Dang, for their constant encouragement and love.

Table of Contents

List of Tables	xii
List of Figures	xiv
1 Introduction	1
1.1 Problem Statement	4
1.2 Research Objectives	6
1.3 Thesis Organization	8
2 Grey Systems Theory and Multiple Criteria Decision Analysis	11
2.1 Grey Systems Theory	11
2.1.1 Fundamental Concepts	12
2.1.2 Grey Relational Analysis	20
2.2 Multiple Criteria Decision Analysis	25
2.2.1 Review of MCDA Approaches	26
2.2.2 PROMETHEE Modelling	28

2.3	Conclusions	30
3	The Grey-based PROMETHEE II Methodology	32
3.1	Introduction	32
3.2	Grey-based PROMETHEE II Methodology	34
3.2.1	Structure of the Grey Decision System	34
3.2.2	Normalizing the Performance of Alternatives	36
3.2.3	Ranking Alternatives based on PROMETHEE II Methodology	42
3.3	Case illustration of Evaluation of Source Water Protection Strategies	46
3.3.1	Background	46
3.3.2	Input Data	48
3.3.3	Normalization of the Performance of Alternatives	50
3.3.4	Results and Analysis	51
3.4	Conclusions	54
4	The Graph Model for Conflict Resolution	56
4.1	Introduction	56
4.2	Theoretical Foundations of the Graph Model for Conflict Resolution	57
4.3	Stability Analysis in a Conflict with Two Decision Makers	60
4.4	Stability Analysis in a Conflict with Multiple Decision Makers	62

4.5	Case Study: Conflict Analysis on Water Use and Oil Sands Development in the Athabasca River	64
4.5.1	Background	64
4.5.2	Water Use and Oil Sands Development Conflict in the Athabasca River Basin	66
4.5.3	Stability Analysis	74
4.6	Conclusions	76
5	Grey-based Preference in a Graph Model for Conflict Resolution with Two Decision Makers	77
5.1	Grey Preference Structure in the Graph Model	79
5.1.1	Grey Preference Degree	80
5.1.2	Grey Relative Certainty of Preference	83
5.1.3	Grey Unilateral Improvement	85
5.2	Grey Stabilities in a Conflict with Two Decision Makers	88
5.3	Case Study: Sustainable Development Conflict under Uncertainty	93
5.3.1	Background	93
5.3.2	Graph Model with Uncertainty	95
5.3.3	Stability Analysis	97
5.3.4	Insights and Sensitivity Analysis	98
5.4	Conclusions	100

6	Grey-based Preference in a Graph Model for Conflict Resolution with Multiple Decision Makers	102
6.1	Grey-based Graph Model for Conflict Resolution with Multiple Decision Makers	102
6.1.1	Grey Unilateral Improvements for a Conflict with Multiple Decision Makers	103
6.1.2	Grey Stabilities Definitions and Equilibria	106
6.2	Negotiation of Brownfield Redevelopment Conflict under Uncertainty	109
6.2.1	Background of Kaufman Site Redevelopment Conflict	109
6.2.2	Grey-based Uncertain Preferences for the Decision Makers	112
6.2.3	Stability Analysis of the Brownfield Redevelopment Conflict	118
6.2.4	Status Quo Analysis	126
6.3	Conclusions	128
7	Contributions and Future Research	129
7.1	Main Contributions	129
7.2	Future Research Plan	132
	References	134

List of Tables

2.1	Grey Relational Analysis Structure	21
3.1	Grey-based Decision Structure	35
3.2	Grey-based Performance Matrix by DM l on Qualitative Criteria	39
3.3	The Importance Degree of DM l	40
3.4	Performance of Alternative i on Qualitative Criterion j Evaluated by Decision Maker l	40
3.5	Importance Degrees of Decision Makers	48
3.6	Weights of Criteria	49
3.7	Performance of Source Water Protection Strategies on Qualitative Criteria	49
3.8	Performance of Source Water Protection Strategies on Quantitative Criteria	50
3.9	Normalized Importance Degrees of Decision Makers	50
3.10	Normalized Performance of Alternatives on Criteria	51
3.11	Multiple Criteria Preference Matrix	52
3.12	Netflow of Alternatives	53

4.1	Decision Makers and Their Options	69
4.2	Decision Makers, Options and Feasible States	70
4.3	Preference Ordering Principals for the Alberta Government	71
4.4	Preference Ordering Principals for Oil Sands Companies	72
4.5	Preference Ordering Principals for NGOs	72
4.6	Stability Results for the conflict of water use and oil sands development	75
5.1	Feasible States for the Sustainable Development Conflict	94
5.2	Grey Preference Matrices of ENV and DEV	96
5.3	Grey relative certainty of Preferences of ENV and DEV	97
5.4	Stability Results for the Sustainable Development Conflict under Uncertainty - with Neutral DEV	98
5.5	Stability Findings for the Sustainable Development Conflict under Uncertainty - with Pessimistic DEV	100
5.6	Stability Results for the Sustainable Development Conflict under Uncertainty - with Optimistic DEV	101
6.1	DMs, Options, and States in the Acquisition Conflict of Brownfield Redevelopment (Modified from (Bernath Walker et al., 2010))	111
6.2	Grey Preference Matrices of PO	113
6.3	Grey Preference Matrices of CG	114
6.4	Grey Preference Matrices of D	115

6.5	Grey Relative Preference Matrices of PO	116
6.6	Grey Relative Preference Matrices of CG	117
6.7	Grey Relative Preference Matrices of D	117
6.8	Anticipated Preferences of the Decision Makers in the Conflict	119
6.9	Stability Results for Brownfield Redevelopment Conflict under Uncertainty	123
6.10	Status Quo Analysis	127

List of Figures

1.1	Thesis Organization	10
2.1	Distinguishing Grey Numbers from Probability Distributions and Fuzzy Numbers	16
2.2	Grey Relational Degree: Reference Sequence versus Alternatives (Zhai et al., 2009)	20
3.1	Flow Chart of Grey-based PROMETHEE II Methodology	33
3.2	The Preference Degree of Alternative a over Alternative b	44
4.1	Integrated Transitional Graph of Water Use and Oil Sands Development Conflict in the Athabasca River Basin	73
5.1	Main Contributions within the Framework of Conflict Analysis	78
5.2	The Graph Model of Movement for the Sustainable Development Conflict	95
6.1	A Graph Model for a Simple Conflict	104
6.2	Flow Chart for grey-based Graph Model for Conflict Resolution	108

6.3	Integrated Directed Graph of the Property Acquisition Conflict (Modified from (Bernath Walker et al., 2010))	112
6.4	Directed Graph for PO Holding Different Grey Satisficing Thretholds	120
6.5	Directed Graph for D Holding Different Grey Satisficing Thretholds	121
6.6	Directed Graph for CG Holding Different Grey Satisficing Thretholds	122
6.7	Grey Unilateral Improvements and Potential Sanctions (GST: PO = 0.1, D = 0.6, CG = 0.2)	124
6.8	Grey Unilateral Improvements and Protential Sanctions for DMs (GST: PO = 0.1, D = 0.6, CG = 0.2)	125
6.9	Grey Unilateral Improvements and Protential Sanctions for DMs (GST: PO = 0.9, D = 0.8, CG = 0.6)	126

Chapter 1

Introduction

Decision making is a central activity in the daily lives of most human beings, especially in fields like economics and management. It can be considered to be a systematic process of identifying and selecting alternatives according to available information or preferences of a decision maker (DM) or multiple DMs ([Janis and Mann, 1977](#)). Decision theories are generally classified into three categories: normative, descriptive and prescriptive. A normative decision theory indicates how a decision should be made in theory, on the assumption that a DM is fully rational; a descriptive decision theory describes what a DM actually does in specific situations; and a prescriptive decision theory concentrates on how a DM ought to act with the purpose of improving the outcomes, despite imperfect information ([Baron, 2000](#); [Pratt et al., 1995](#); [Tversky and Kahneman, 1986](#)). With the development of decision theories, it is hard to strictly characterize them according to the three aforementioned categories. This research focuses on refining normative and prescriptive theories and making them more suitable to reflect modern decision problems.

In real-world applications, decision problems are frequently vast, complex and ill-

defined. Taking source water protection as an example, both tangible and intangible criteria must be considered by DMs, including benefits; investment costs; projected operating costs; water quantity and quality risks; and technical, operational, legal and social feasibility. [Hipel et al. \(1993\)](#) suggested four factors that affect the circumstances in which a decision problem must be addressed: *(i)* whether the context includes uncertainty; *(ii)* whether the courses of action can be completely assessed in quantitative terms; *(iii)* whether multiple objectives must be taken into account; and *(iv)* whether a single DM or multiple DMs are involved. Based on these factors, decision methodologies are classified into four categories: single participant—single criterion, single participant—multiple criteria, multiple participants—single criterion, and multiple participants—multiple criteria.

In principle, Multiple Criteria Decision Analysis (MCDA) is a single participant—multiple criteria decision making technique, although it can easily be adopted for use by a group of DMs ([Belton and Pictet, 1997](#)). MCDA constitutes a methodology that includes techniques to guide DMs in identifying and structuring decision problems, and in explicitly aggregating and evaluating multiple alternatives in decision environments ([Guitouni and Martel, 1998](#); [Steward, 1992](#); [Ozernoy, 1992](#)). During the last 40 years, scientists and practitioners not only accelerated the theoretical and technical development of MCDA within the field of Operational Research and elsewhere, but also gained valuable experience through applications to decision problems in many areas including environmental sciences, social sciences, education, and health care ([Flores-Alsina et al., 2008](#)).

When two or more DMs are involved in a decision situation, a conflict may arise as the DMs interact with others to further their own interests, which are often different ([Hipel, 2009a](#); [Kilgour and Eden, 2010](#)). Each DM may have his or her own criteria to determine preference among the possible scenarios. Hence, each DM may have his or her multiple criteria decision problem to rank scenarios. Strategic conflicts are interactive decision

problems, in which each DM controls one or more options and attempts to achieve the most preferable scenario. Note that if one DM exercises an option, it may benefit or harm other DMs. Therefore, cooperative or compromise solutions may be available (Kilgour and Hipel, 2005). In practice, these phenomena arise frequently, such as in military strategy, business negotiation, and environmental management (Hipel et al., 1997; Kilgour et al., 1987; Kassab et al., 2006).

The Graph Model for Conflict Resolution (GMCR) constitutes a simple and flexible methodology to model and analyze strategic conflicts (Kilgour et al., 1987). Much valuable research has been conducted on different aspects of this methodology both in theory and in practice (Kilgour et al., 1987). Fang et al. (1993) focused on solution concepts and their interrelationships as well as on how to apply GMCR in practice. Hipel et al. (2009) explained the roles of GMCR and other Operational Research tools to solve problems within a systems engineering context. Kilgour and Hipel (2005) reviewed various initiatives within the GMCR framework and suggested guidelines for future development. To implement the graph model methodology, a user-friendly decision support software, GMCR II, has been developed. It can quickly, completely and reliably model and analyze multiple participant-multiple criteria problems, large or small (Fang et al., 2003a,b).

As a researcher focusing on a class of decision making methodologies aiming to give advice and suggestions to DMs, the author believes that if DMs provide enough information, an optimal result should be obtained; even if DMs' understanding of the problem is limited by incomplete information and uncertainties, reasonable and satisfactory solutions may be available; but if DMs have no information at all, they may have to rely on courage. Reasonable decision methodologies focusing on uncertainty must be considered along with our limited understanding of human cognition and the complexity of real applications in which multiple DMs interact. Uncertainty and conflicts of interest among stakeholders

may complicate the analysis. Consequently, a satisfactory decision negotiated through compromises and trade-offs, which better corresponds to the real world, may be a valuable contribution to the DMs, even if it is not individually optimal.

1.1 Problem Statement

Originally, decision analysis techniques and methodologies were designed for tackling highly structured problems using mathematical procedures to make rational choices based on quantitative data (Checkland, 1981; Hipel et al., 1993; Radford, 1988). The modern solution objective for a decision problem is no longer optimality within a well-defined structure, but satisfaction of DMs under complex circumstances in which qualitative criteria and interaction with other DMs must be considered (Hipel et al., 1993). This research aims to design new or improved methods for MCDA problems with uncertain information, or for conflict resolution having uncertain preferences. In decision analysis, one of the main difficulties is to incorporate uncertainty into decision processes. The natural complexity of multiple criteria assessment and conflict resolution calls for the development of effective and reliable techniques for handling decision problems under uncertainty (Ben-Haim and Hipel, 2002; Hyde, 2006). To address these problems, this thesis begins by classifying uncertainties in decision problems into three types according to the literature (Calizay et al., 2010; Comes et al., 2011; Ekel et al., 2008), as follows:

- **Deficient Understanding of the Decision Structure:** Designing and selecting a mathematical structure is the first step in modelling a decision problem. A logical, well-defined structure based on well-conducted background research and practical experience can catch the essence of a problem, accelerate the decision process, and

accordingly win the trust of stakeholders. On the contrary, an unsatisfactory structure may produce an unjustified recommendation, and mislead or disappoint DMs. However, even a good structure may eventually be improved with deeper understanding and further technical development (Ozernoy, 1992).

- **Limited input data:** The criteria for comparing alternatives may contain both tangible and intangible information so as to provide a comprehensive overview of performance. It may be necessary to take into account comprehensive economic, ecological, political, and social aspects in some specific applications. Furthermore, data may be limited, inconsistent or vague. To conduct rational decision analysis, it is essential to be able to deal with both certain and uncertain input information.
- **Vague Preferences of Stakeholders:** The DMs may qualitatively judge the performance of alternatives based on multiple criteria before stating their preferences. However, a DM may not always be consistent and rational in articulating his or her preferences, and conflicts of interest may exist among stakeholders (Calizay et al., 2010). Moreover, a DM's judgement of alternatives according to a specific criterion may be unclear, leading to a uncertain preference (Li et al., 2007).

In large-scale decision projects, such as source water protection and brownfield redevelopment, researchers and practitioners must deal with a deficient understanding of the problem structure caused by limited human cognition, poorly understood interactions among criteria, alternatives with limited data, and the interplay of stakeholders holding vague preferences. No decision methodology can be appropriate for application to all decision situations, but proper methods for a specific class of decision problems can be designed based on its characteristics (Guitouni and Martel, 1998).

1.2 Research Objectives

This research attempts to employ and customize grey systems theory to produce methodologies for solving decision problems under uncertainty and to use grey numbers in grey systems theory to construct a more general uncertain structure with application to challenging decision issues arising in engineering and other fields. Up to now, there has been no systematic application of grey systems theory techniques to MCDA and GMCR, and researchers have paid little attention to important theoretical concepts related to grey systems theory, such as grey sets and grey numbers.

Grey systems theory constitutes a valuable alternative for representing uncertainty in modelling decision problems. Grey systems theory can provide an insightful view of decision problems and accordingly help DMs understand their decision structure, rearrange their strategies, reinforce their models, and make reasonable choices. The basic concepts of grey systems theory can effectively deal with representation and processing of both vague and incomplete information. The distinctions of grey systems theory with other methodologies are further explained as follows:

- In semi-structured or unstructured decision problems, information may be uncertain (Klein, 2008). Grey systems theory can effectively represent quantitative and qualitative information and express uncertainty in a general way. Therefore, this method is more suitable for the evaluation and assessment of alternatives (Liu and Lin, 2010).
- Most of the time, a DM may offer imprecise information, which can be represented by sets of values, intervals of values or combinations of them. The linguistic method is a widely accepted technique to represent DMs' uncertain preference over alternatives (Wei, 2011). This method requires relatively low cognitive effort and perfectly

matches the characteristics of grey systems theory. Grey systems theory can assess linguistic values of alternatives based on the theorems, and operating rules of grey numbers, thereby exploiting calculation processes to rank alternatives through the effective combination of grey systems theory and other MCDA techniques.

- A grey number can represent both discrete values and interval values. Some real-world problems may require the selection of one value among a limited number of options. For example, there are three coloured balls in a black bag, and you must pick one of them. Suppose each ball is either red or black. If you pick one of them, the number of red balls you have is a discrete grey number, which must equal 0 or 1. This kind of problem can be easily represented by discrete grey numbers. Moreover, a generalised grey number may represent a preference in a conflict with discrete values, interval values, or any of their combinations. Based on general grey numbers, a general preference structure can be set up in GMCR.

Based on the characteristics of grey systems theory, theoretical research will be carried out in this thesis starting with the definition of a grey number, and incorporating it into MCDA and GMCR. The methods of grey systems theory, such as grey relational analysis and the grey target decision method, will be investigated systemically and combined with typical MCDA techniques to identify preferred or indifferent alternatives, to eliminate inferior alternatives, and to determine alternatives reflecting potential compromises in MCDA under uncertainty. Moreover, grey-based preference methods and related methodologies will be developed in the context of GMCR. A new uncertain preference structure will be constructed based on generalized grey numbers, thereby permitting moves and counter moves of DMs with uncertain preferences to be discussed, and solution concepts to be put forward. This research will also take a practical perspective, by combining grey systems

theory with other techniques and applying them to specific problems.

1.3 Thesis Organization

The thesis consists of seven chapters. Its organisation is shown in Figure 1.1.

- This thesis begins (Chapter 1) with a general introduction to decision problems to provide a motivation for the research and setting out the objectives.
- Chapter 2 reviews some mainstream methods and describes fundamental notation and definitions of MCDA and grey systems theory.
- Chapter 3 proposes a grey-based Preference Ranking Organization Method for Enrichment Evaluations (PROMETHEE) II methodology to handle multiple criteria decision problems with ill-defined information. A case study regarding the evaluation of source water protection strategies is presented to show the feasibility of this methodology.
- Chapter 4 reviews the fundamental concepts and stability definitions of a graph model. A conflict on water use and oil sands development in the Athabasca River in Alberta, Canada, is developed and analyzed to show how this methodology can be applied to strategic conflicts.
- Chapter 5 puts forward a grey-based GMCR model. In this methodology, a grey-based preference structure is provided based on generalized grey numbers, and stability definitions are introduced in a graph model for conflict resolution having two DMs.

- Chapter 6 extends the grey-based preference structure to represent uncertain preferences when multiple DMs are involved in a conflict. Appropriate solution concepts are defined in grey-based GMCR with two or more DMs.
- Chapter 7 summaries the key research contributions contained in this thesis and puts forward suggestions for future work.

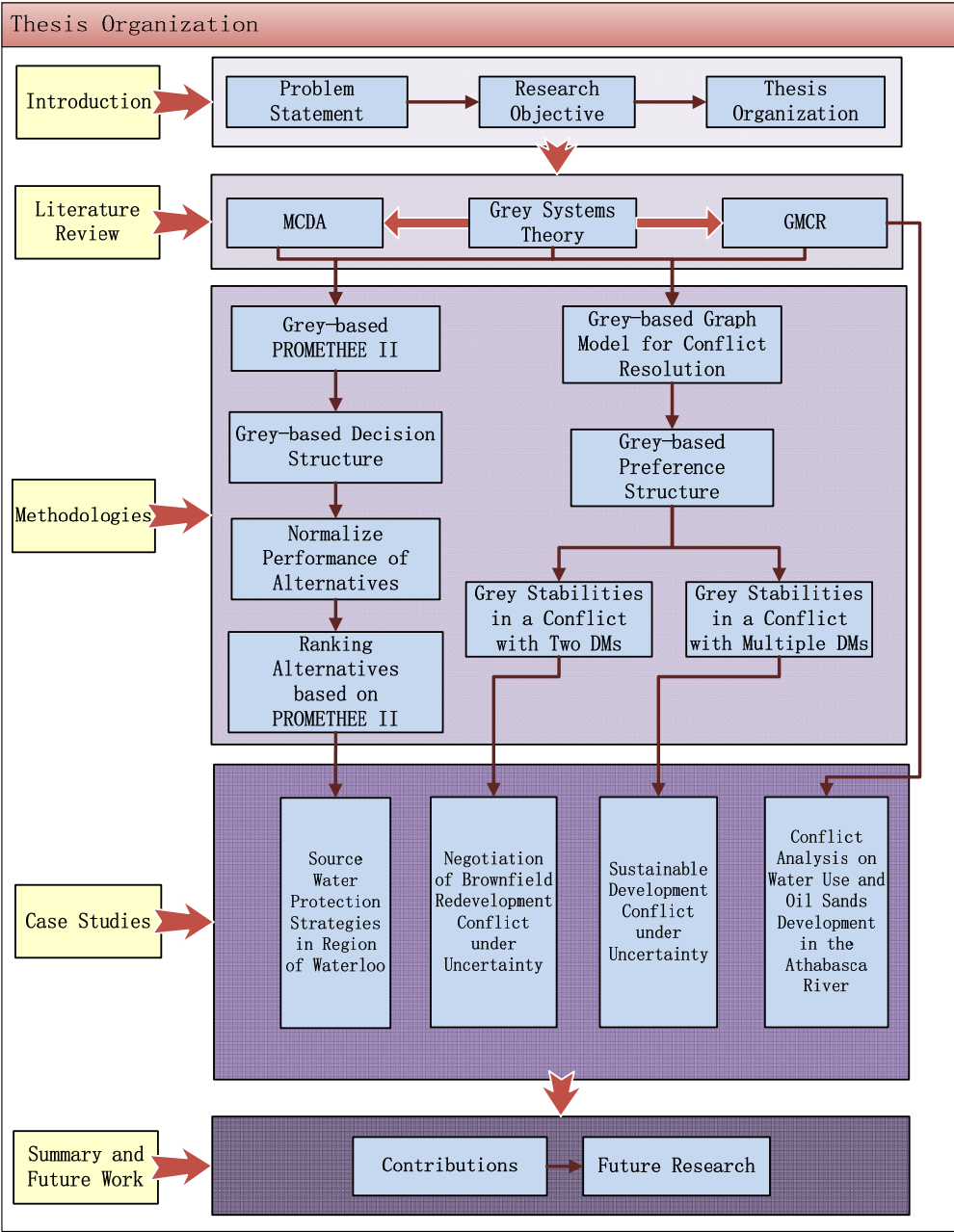

Figure 1.1: Thesis Organization

Chapter 2

Grey Systems Theory and Multiple Criteria Decision Analysis

In this chapter, two families of methodologies are summarised: Grey Systems Theory and Multiple Criteria Decision Analysis (MCDA). In each section, essential literature is reviewed and classified, and mathematical notation and definitions are provided along with detailed explanation.

2.1 Grey Systems Theory

Grey Systems Theory, originally put forward by [Deng \(1982\)](#), is a methodology that focuses on addressing problems with imperfect numerical information, which may be discrete or continuous ([Deng, 1989](#); [Liu and Forrest, 2010](#)). In grey systems theory, a system with information that is certain is called a White System; a system with information that is totally unknown is referred to as a Black System; a system with partially known and partially

unknown information is called a Grey System. The theory contains five main parts: Grey Prediction Models, Grey Relational Analysis (GRA), Grey Models for Decision Making, Grey Game Models, and Grey Control Systems (Liu and Forrest, 2010). The methodologies can effectively handle representation and processing of vague or uncertain information, and it can give insights into operational features of systems and their evolution.

A crucial feature of a method for solving decision problems under uncertainty is how it deals with uncertain information (Greco et al., 2001). Grey systems theory, in particular, possesses many desirable characteristics. Firstly, it can handle uncertain problems with small samples and poor information. Secondly, grey numbers can represent not only one or more discrete values but also intervals of numbers, depending on the DMs' opinions. Thirdly, grey systems theory uses the concept of degree of greyness to estimate the uncertainty of grey numbers, rather than a typical distribution of their values (Liu and Forrest, 2010; Yang and John, 2012). However, most researchers and practitioners focus on grey relational analysis and its combination with other techniques, with little attention paid to theoretical foundations and extensions of definitions of grey numbers and associated theorems to make them more suitable to decision analysis or conflict resolution. The following subsection will systematically review mathematical concepts of grey systems theory with examples to make them easier to understand.

2.1.1 Fundamental Concepts

This research presents fundamental grey concepts, including the definitions and theorems of grey numbers, core of grey numbers, degree of greyness, and grey sets. A definition of general grey number put forward by Yang et al. (2004) is also introduced in this section. After that, the method of grey relational analysis is reviewed. This method is particularly

applicable in decision problems with very limited data and vague information.

Grey Numbers

A grey number is the most fundamental concept in grey systems theory. In the original definitions, a white number is a real number, $x \in \mathbb{R}$. A grey number, written $\otimes x$, means an indeterminate real number that takes its possible values within an interval or a discrete set of numbers. Let $G[\mathbb{R}]$ denotes the set of all grey numbers within the set of real numbers, \mathbb{R} , the definitions of discrete grey numbers, continuous grey numbers, and general grey numbers are presented as follows:

Definition 2.1 *A discrete grey number $\otimes x$ is an unknown real number with a clear lower bound \underline{x} and an upper bound \bar{x} , $\underline{x}, \bar{x} \in \mathbb{R}$, taking its value from the closed interval, $[\underline{x}, \bar{x}]$, denoted (Liu and Forrest, 2010):*

$$\otimes x \in \{x_1, x_2, \dots, x_k\} \quad (2.1)$$

Note that the lower bound $\underline{x} = \min_i x_i$ and the upper bound $\bar{x} = \max_i x_i$, $1 \leq k < \infty$. When $\underline{x} = \bar{x}$, the discrete grey number becomes a white number, $\otimes x = x = \underline{x} = \bar{x}$.

Definition 2.2 *A continuous grey number $\otimes x$ is an interval, and is thought of as potentially taking a value within that interval. Generally, it can be expressed as one of three types, as follows (Liu and Forrest, 2010):*

- *Continuous grey number with a definite, known lower bound \underline{x} , written as*

$$\otimes x \in [\underline{x}, +\infty)$$

- Continuous grey number with a definite, known upper bound \bar{x} , written as

$$\otimes x \in (-\infty, \bar{x}]$$

- Continuous grey number with both a lower bound \underline{x} and an upper bound \bar{x} , written as

$$\otimes x \in [\underline{x}, \bar{x}], \underline{x} \leq \bar{x}, \text{ and } \underline{x}, \bar{x} \in \mathbb{R} \quad (2.2)$$

Note that when $\underline{x} = \bar{x}$, the continuous grey number becomes a white number with a single crisp value.

Definition 2.3 A general grey number, $\otimes x$, is a real number that is not known but has a clear lower bound and an upper bound, \underline{x} and $\bar{x} \in \mathbb{R}$, respectively, taking its value from the closed interval, $[\underline{x}, \bar{x}]$, denoted as (Yang and John, 2012):

$$\otimes x \in \bigcup_{i=1}^k [\underline{x}_i, \bar{x}_i] \quad (2.3)$$

where $1 \leq k < \infty$, $\underline{x}_i, \bar{x}_i \in \mathbb{R}$, and $\bar{x}_{i-1} < \underline{x}_i \leq \bar{x}_i < \underline{x}_{i+1}$, $\underline{x} = \min_i \underline{x}_i$, and $\bar{x} = \max_i \bar{x}_i$.

Note that (2.3), put forward by Yang and John (2012), generalizes definitions proposed earlier by Liu and Forrest (2010). A general grey number, is a real number that has a precise lower and upper bound, but its position between the lower and upper bounds is not known. It may be a member of a discrete set of real numbers, may fall within an interval of real numbers, or reside within any combination of intervals and discrete sets. Some illustrations of general grey numbers are as follows:

- If $\underline{x}_i = \bar{x}_i = x_i$ for all $i = 1, 2, \dots, k$, then $\otimes x \in \{x_1, x_2, \dots, x_k\}$ is a grey number (a member of a discrete set).

- If $k = 1$ and $\underline{x} \neq \bar{x}$, then $\otimes x \in [\underline{x}, \bar{x}]$ is a grey number (a real number residing within an interval).
- If $\underline{x}_i = \bar{x}_i = x$ and $k = 1$, then $\otimes x = x \in \mathbb{R}$ is a grey number (a white number).
- If $x = \underline{x}_p = \bar{x}_p$, $x = \underline{x}_q = \bar{x}_q$ for $1 \leq p, q \leq k$, then $\otimes x = \{x_p, x_q, \bigcup_{i \neq p, q}^k [\underline{x}_i, \bar{x}_i]\}$ is a grey number (a real number falls within an union of real numbers, p and q , and $k - 2$ intervals).

Example 2.1 Three grey numbers, $\otimes x_1 \in \{0.1, 0.2, 0.3\}$, $\otimes x_2 \in [0.2, 0.4]$, and $\otimes x_3 \in \{[0.1, 0.2], [0.3, 0.5], [0.6, 0.8]\}$ constitute a discrete set of real numbers, an interval, and an union of intervals and real numbers, respectively.

Let $\otimes x_1$ and $\otimes x_2$ be two general grey numbers, $\otimes x_1 \in \bigcup_{i=1}^m [\underline{x}_i, \bar{x}_i]$, $\otimes x_2 \in \bigcup_{j=1}^n [\underline{x}_j, \bar{x}_j]$, and $1 \leq m, n < \infty$. The mathematical operation rules of general grey numbers are:

$$\otimes x_1 + \otimes x_2 \in \bigcup_i^m \bigcup_j^n [\underline{x}_i + \underline{x}_j, \bar{x}_i + \bar{x}_j] \quad (2.4)$$

$$\otimes x_1 - \otimes x_2 \in \bigcup_i^m \bigcup_j^n [\underline{x}_i - \bar{x}_j, \bar{x}_i - \underline{x}_j] \quad (2.5)$$

$$\otimes x_1 \times \otimes x_2 \in \bigcup_i^m \bigcup_j^n \left[\min \left(\underline{x}_i \underline{x}_j, \underline{x}_i \bar{x}_j, \bar{x}_i \underline{x}_j, \bar{x}_i \bar{x}_j \right), \max \left(\underline{x}_i \underline{x}_j, \underline{x}_i \bar{x}_j, \bar{x}_i \underline{x}_j, \bar{x}_i \bar{x}_j \right) \right] \quad (2.6)$$

$$\otimes x_1 \div \otimes x_2 \in \bigcup_i^m \bigcup_j^n \left[\min \left(\frac{\underline{x}_i}{\underline{x}_j}, \frac{\underline{x}_i}{\bar{x}_j}, \frac{\bar{x}_i}{\underline{x}_j}, \frac{\bar{x}_i}{\bar{x}_j} \right), \max \left(\frac{\underline{x}_i}{\underline{x}_j}, \frac{\underline{x}_i}{\bar{x}_j}, \frac{\bar{x}_i}{\underline{x}_j}, \frac{\bar{x}_i}{\bar{x}_j} \right) \right] \quad (2.7)$$

Note that for 2.7, it is assumed that $\bar{x}_j < 0$ or $\underline{x}_j > 0$; otherwise, the operation is undefined.

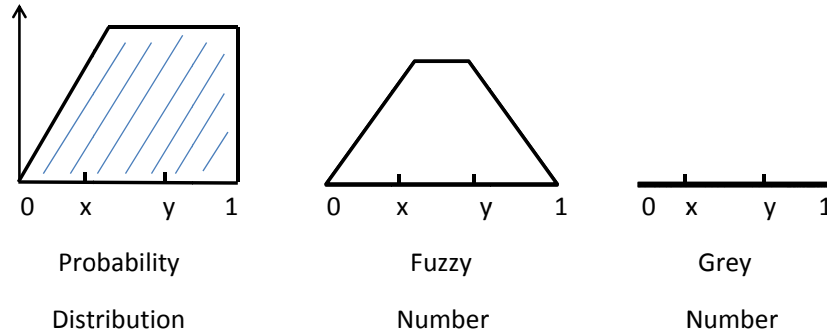

Figure 2.1: Distinguishing Grey Numbers from Probability Distributions and Fuzzy Numbers

A grey number is only one way to model uncertainty, and can be usefully compared to a probability distribution and a fuzzy number. In Figure 2.1, the left panel represents a probability distribution on $[0, 1]$, the middle diagram shows the membership of a fuzzy number with lower bound 0 and upper bound 1, and the right panel represents the grey number $[0, 1]$. Note that the probability distribution contains more information than the fuzzy number, but the probability distribution and the fuzzy number both permit relative comparison of x and y for $0 \leq x < y \leq 1$, while the grey number contains no information about such a comparison. Since grey numbers don't consider the distribution of possible values, they can handle decision problems with very limited information.

Kernel of a Grey Number

In grey systems theory, a grey number is a real number which falls within a discrete set of real numbers, an interval of real numbers, or any combination of intervals and discrete sets.

The operation, which can transfer a grey number into a white number is whitenisation. The kernel of a grey number is a white number, which is most likely to be the real value of the grey number. [Liu and Fang \(2006\)](#) defined the expected value of a grey number as its kernel.

Definition 2.4 *Let $\otimes x$ be a grey number, the expected value $\hat{\otimes}x$ is its kernel.*

- *If $\otimes x$ is a discrete grey number, and $\otimes x \in \{x_1, x_2, \dots, x_k\}$, $x_i \in \mathbb{R}$, $i = 1, 2, \dots, k$ and $1 \leq k < \infty$, then ([Liu and Fang, 2006](#))*

$$\hat{\otimes}x = \frac{1}{k} \sum_{i=1}^k x_i \quad (2.8)$$

- *If $\otimes x$ is a continuous grey number, and $\otimes x \in [\underline{x}, \bar{x}]$, where $\underline{x}, \bar{x} \in \mathbb{R}$, $\underline{x} \leq \bar{x}$, then ([Liu and Fang, 2006](#))*

$$\hat{\otimes}x = \frac{1}{2}(\underline{x} + \bar{x}) \quad (2.9)$$

- *If $\otimes x$ is a general grey number, and $\otimes x \in \bigcup_{i=1}^k [\underline{x}_i, \bar{x}_i]$, where $1 \leq k < \infty$, $\underline{x}_i, \bar{x}_i \in \mathbb{R}$, and $\bar{x}_{i-1} < \underline{x}_i \leq \bar{x}_i < \underline{x}_{i+1}$, $\underline{x} = \min_i \underline{x}_i$, and $\bar{x} = \max_i \bar{x}_i$, then*

$$\hat{\otimes}x = \begin{cases} \frac{1}{n} \sum_{i=1}^n \underline{x}_i, & \text{if } \underline{x}_i = \bar{x}_i \text{ for all } i = 1, 2, \dots, k \\ \frac{\sum_{i=1}^n (\bar{x}_i - \underline{x}_i) (\frac{\bar{x}_i + \underline{x}_i}{2})}{\sum_{i=1}^n (\bar{x}_i - \underline{x}_i)}, & \text{otherwise} \end{cases} \quad (2.10)$$

Degree of Greyness

The degree of greyness reflects the understanding of the uncertainty that is involved in a decision problem. It can represent the vagueness of input data or a range of possible values to choose from.

Definition 2.5 Let $\otimes x$ be a general grey number, $\otimes x = \bigcup_i^k [\underline{x}_i, \bar{x}_i]$, and the lower bound $\underline{x} = \min_i \underline{x}_i$ the upper bound $\bar{x} = \max_i \bar{x}_i$. The range of the grey number $\otimes x$ is defined in (Liu and Forrest, 2010; Yang and John, 2012)

$$u(\otimes x) = |\bar{x} - \underline{x}| \quad (2.11)$$

Definition 2.6 Let U be a finite universe of discourse, $U \subseteq \mathbb{R}$ and $\otimes x \in U$. $u(\otimes x)$ is the range of grey number $\otimes x$. The degree of greyness $g^\bullet(\otimes x)$ of the general grey number $\otimes x$ is defined as (Liu and Forrest, 2010; Yang and John, 2012):

$$g^\bullet(\otimes x) = u(\otimes x)/u(U) \quad (2.12)$$

Note that $u(U) = |U_{max} - U_{min}|$, and U_{max} , U_{min} are respectively the lower and upper bounds of U .

Theorem 2.6.1 $0 \leq g^\bullet(\otimes x) \leq 1$ The degree of greyness ranges from 0 to 1.

Theorem 2.6.2 $g^\bullet(U) = 1$. The degree of greyness for the finite universe of discourse is always equal to 1.

Theorem 2.6.3 For any discrete grey number $\otimes x \in \{x_1, x_2, \dots, x_k\}$, when $x_1 = x_k$, $g^\bullet(\otimes x) = 0$; for any continuous grey number $\otimes x \in [\underline{x}, \bar{x}]$, $\underline{x} \leq \bar{x}$, when $\underline{x} = \bar{x}$, $g^\bullet(\otimes x) = 0$.

It is obvious that when $g^\bullet(\otimes x) = 0$, $\otimes x$ is a white number with specific value; when $g^\bullet(\otimes x) = 1$, $\otimes x$ is a black number, and it can be considered as unknown.

Grey Set and Grey Sequence

In the following, $D[0, 1]^\otimes$ represents the set of all grey numbers within the interval $[0, 1]$. The grey number $\otimes x$ may be a continuous grey number $\otimes x \in [\underline{x}, \bar{x}]$, a discrete grey number $\otimes x \in \{x_1, x_2, \dots, x_k\}$ or a general grey number $\otimes x \in \bigcup_{i=1}^k [x_i, \bar{x}_i]$.

Definition 2.7 Let U be a universal set, and $x \in U$; if $G \subseteq U$ is such that the characteristic function value of x with respect to G can be expressed by a grey number $\otimes x \in D[0, 1]^\otimes$, then G is a grey set (Yang et al., 2004; Yang and John, 2012)

The characteristic function here is a general expression, and may be expressed by probability function, membership function, etc (Yang and John, 2012).

Definition 2.8 A decision system contains m alternatives and n criteria. Let A_i , $i = 1, 2, \dots, m$ and $1 \leq m < \infty$, be the i th alternative, and its values on criterion j is $\otimes x_i(j)$, $j = 1, 2, \dots, n$ and $1 \leq n < \infty$. The behavioural grey sequence of the alternative $\otimes X_i$ is denoted as:

$$\otimes X_i = (\otimes x_i(1), \otimes x_i(2), \dots, \otimes x_i(j), \dots, \otimes x_i(n)). \quad (2.13)$$

here $\otimes X_i$ is a simple form of $\otimes X(A_i)$, and the value $\otimes x_i(j)$ may be a white number, discrete grey number, continuous grey number or general grey number.

In MCDA, $\otimes X_i$ represents the i th alternatives, and $\otimes x_i(j)$ denotes performance of the i th alternatives on the j th criterion. Using grey numbers to reflect the characteristics

of the decision system, we can handle input data with quantitative white numbers and imperfect information with grey numbers. The definition of a grey sequence can represent uncertainties in a more general way.

2.1.2 Grey Relational Analysis

Grey Relational Analysis (GRA) is a technique that can deal with MCDA problems with incomplete information. In MCDA, input data with respect to various criteria (usually conflicting) usually show that the relationship between two alternatives is complex. GRA treats each alternative as a sequence of data based on criteria, and calculates the grey relational degree between each alternative and the reference sequence, which is a generated ideal solution representing the best performance on the criteria. [Zhai et al. \(2009\)](#) provided a diagram, Figure 2.2, to show the mechanism of GRA. A higher value of the grey relational degree between an alternative and the reference sequence indicates better performance of the alternative ([Ng, 1994](#)).

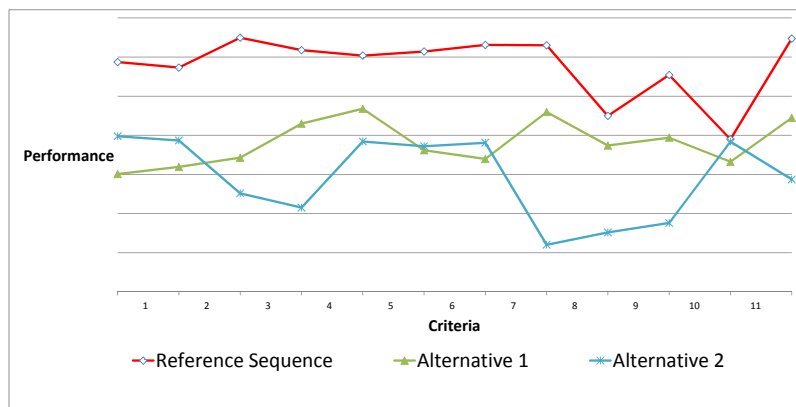

Figure 2.2: Grey Relational Degree: Reference Sequence versus Alternatives ([Zhai et al., 2009](#))

Conventional GRA modelling involves five steps: (i) construction of an evaluation

structure, (ii) transformation of alternatives into comparability sequences and of the normalized performance matrix, (iii) derivation of reference sequences, (iv) calculation of grey relational coefficients, (v) determination of the grey relational degree. Explanations and mathematical expressions of these steps are provided (Chan and Tong, 2007; Liou et al., 2011; Zhai et al., 2009; Zhang et al., 2011):

Step 1 **Construction of an Evaluation Structure:** For an MCDA problem, let $A = \{A_1, A_2, \dots, A_i, \dots, A_n\}$ be the set of alternatives, and $C = \{C_1, C_2, \dots, C_j, \dots, C_m\}$ be the set of criteria, where $1 < m, n < \infty$. The performance of alternative A_i is represented as $V_i = (V_{i1}, V_{i2}, \dots, V_{ij}, \dots, V_{im})$, where V_{ij} denotes the value of alternative A_i on criterion C_j . These parameters are represented in Table 2.1.

Table 2.1: Grey Relational Analysis Structure

		Alternatives					
		A_1	A_2	...	A_i	...	A_n
Criteria	C_1						
	C_2				↓		
	...						
	C_j		→		V_{ij}		
	C_m						

Step 2 **Generation of Normalized Performance Matrix:** The main objective of normalizing the performance matrix is to transform the alternative $A_i = (V_{i1}, V_{i2}, \dots, V_{ij}, \dots, V_{im})$ into a comparability sequence $A_i' = (V_{i1}', V_{i2}', \dots, V_{ij}', \dots, V_{im}')$ according to the three types of criteria: increasing, decreasing, and targeted.

- Increasing Criterion: If a larger value of V_{ij} always indicates better performance of alternative A_i , then

$$V_{ij}' = \frac{V_{ij} - \min_k V_{kj}}{\max_k V_{kj} - \min_k V_{kj}} \quad (2.14)$$

$$i = 1, 2, \dots, n, j = 1, 2, \dots, m$$

- Decreasing Criterion: If a smaller value of V_{ij} indicates better performance of alternative A_i , then

$$V_{ij}' = \frac{\max_k V_{kj} - V_{ij}}{\max_k V_{kj} - \min_k V_{kj}} \quad (2.15)$$

$$i = 1, 2, \dots, n, j = 1, 2, \dots, m$$

- Targeted Criterion: If a value of V_{ij} closer to the target value V_j^* indicates better performance of alternative A_i , then

$$V_{ij}' = 1 - \frac{|V_{ij} - V_j^*|}{\max\{\max_k V_{kj} - V_j^*, V_j^* - \min_k V_{kj}\}} \quad (2.16)$$

$$i = 1, 2, \dots, n, j = 1, 2, \dots, m$$

In (2.16), V_j^* is the target value for the j th criterion, and $\min_k V_{kj} \leq V_j^* \leq \max_k V_{kj}$.

After the normalization, all three types of criteria have been transformed into increasing criteria, in which a larger value of V_{ij}' indicates better performance of the

alternative. The normalized performance matrix is

$$V' = \begin{bmatrix} V_{11}' & V_{21}' & \dots & V_{n1}' \\ V_{12}' & V_{22}' & \dots & V_{n2}' \\ \dots & \dots & \dots & \dots \\ V_{1m}' & V_{2m}' & \dots & V_{nm}' \end{bmatrix} \quad (2.17)$$

Step 3 Derivation of Reference Sequences: After normalization of the performance matrix, the performance values of alternatives according to criteria range from 0 to 1. Let $V_{0j}' = \max_k V_{kj}'$ represents the highest value among all alternatives on criterion j . Then the reference sequence is denoted as

$$V_0' = (V_{01}', V_{02}', \dots, V_{0j}', \dots, V_{0m}') \quad (2.18)$$

Step 4 Calculation of Grey Relational Coefficients: The grey relational coefficient $\gamma_{ij}(V_{0j}', V_{ij}')$ aims to measure the similarity of a normalized value V_{ij}' to the reference value V_{0j}' . The grey relational coefficient is calculated using (2.19).

$$\gamma_{ij}(V_{0j}', V_{ij}') = \frac{\min_p \min_q |V_{0q}' - V_{pq}'| + \zeta \max_p \max_q |V_{0q}' - V_{pq}'|}{|V_{0j}' - V_{ij}'| + \zeta \max_p \max_q |V_{0q}' - V_{pq}'|} \quad (2.19)$$

$$i = 1, 2, \dots, n, j = 1, 2, \dots, m; \zeta \in [0, 1].$$

In (2.19), ζ is a coefficient used to adjust the significance of $\max_p \max_q |V_{0q}' - V_{pq}'|$. A typical value of ζ is 0.5, which makes the grey relational coefficient moderately significant (Yiyo Kuo, 2008; Zhai et al., 2009).

Step 5 **Determination of Grey Relational Degree:** Given all the grey relational coefficients of normalized values with respect to reference values, the grey relational degree of an alternative with respect to the reference sequence can be formulated as follows:

$$\gamma(A_0, A_i) = \sum_{j=1}^m w_j \gamma(V_{0j}, V'_{ij}) \quad (2.20)$$

where w_j represents the weight on criteria j , and $\sum_{j=1}^m w_j = 1$.

The main objective of grey relational degree is to calculate the magnitude of correlation between alternatives and the reference sequence. Therefore, an alternative with higher grey relational degree with respect to the reference sequence can be identified as a better solution.

Grey systems theory is receiving increasing attention in the field of decision making, and has been successfully applied to many important problems featuring uncertainty. [Chan and Tong \(2007\)](#) used grey relational analysis in multiple criteria material selection; [Li et al. \(2007\)](#) developed a grey-based approach to deal with supplier selection; [Özcan et al. \(2011\)](#) made a comparison among various multiple criteria decision analysis methods and grey relational analysis, and then applied grey relational analysis to a warehouse selection problem; [Liou et al. \(2011\)](#) provided another application aimed at improving airline service quality. During the last decade, increasing applicability of grey systems theory motivated many researchers to compare it with related techniques and invent new combinations. [Zhang et al. \(2005\)](#) investigated grey related analysis using fuzzy interval numbers; [Wei \(2011\)](#) extended grey systems theory to investigate intuitionistic fuzzy multiple attributes decision problems; and [Tseng \(2010\)](#) combined linguistic preferences with grey relational analysis in fuzzy environmental management.

2.2 Multiple Criteria Decision Analysis

After more than forty years of development of MCDA, a large variety of methodologies and technical tools have been developed to assist a DM(s) in solving a decision problem among a set of alternatives, taking into account multiple criteria. The MCDA methodologies, mainly focusing on choosing, sorting and ranking problems, can be classified into four steps (Guitouni and Martel, 1998; Roy, 1991), namely:

- **Structure the Decision Situation and Model the Problem.** The structure of the decision problem includes identification of the stakeholders, verification of the objectives and criteria, specification and selection of the decision alternatives, and clarification of the problematic.
- **Articulate and Model DMs' Preferences.** The preference model must be formulated and validated to ensure that it includes all the relevant information about the DMs' preferences.
- **Aggregate the Alternative Evaluations in terms of the Criteria.** A proper MCDA technique assesses the alternatives by evaluation and comparison based on the requirements of the DMs. It is also called Multiple Criteria Aggregation Procedures (MCAP).
- **Formulate a Recommendation and Implement the Solution.** Further analysis may be needed to provide detailed guidance based on the calculation results.

2.2.1 Review of MCDA Approaches

MCDA is widely used as an integrated methodology for systematic decision making according to multiple criteria. With the rapid development of MCDA, numerous theoretical and practical advances have been achieved, and significant reviews have been presented by several researchers: [Ozernoy \(1992\)](#), and [Guitouni and Martel \(1998\)](#) articulated guidelines for choosing an appropriate MCDA method in different situations; [Steward \(1992\)](#), [Vincke \(1992\)](#), [Belton and Stewart \(2002\)](#), and [Greco \(2004\)](#) presented exhaustive reviews of MCDA approaches, classifying and summarizing classical methods and putting forward some challenging issues; [Dyer et al. \(1992\)](#) focused on the development of Multiple Attribute Utility Theory (MAUT), and describing some aspects of MAUT, which they updated 16 years later ([Wallenius et al., 2008](#)). All of these works contributed tremendously to the development of MCDA. Based on the previous reviews, the conventional theoretical methods in the field of MCDA can be distinguished into three major categories.

- **Multiple Objective Optimisation (MOO)** Dealing with a decision problem, a DM may have several objectives that need to be satisfied simultaneously. In this situation, it may be hard to generate an optimal solution. The main purpose of MOO is to seek satisfactory, non-dominated options, in another words, to generate solutions that can provide suitable performance over all objectives for the DM. Goal programming and evolutionary multiple objective optimisation are well developed in this field ([Charnes and Cooper, 1977](#); [Coello et al., 2007](#); [Marler and Arora, 2004](#); [Tamiz et al., 1998](#)).
- **Value-focused Approaches or Multiple Attribute Utility Theory (MAUT)** Value-focused approaches were put forward by [Keeney and Raiffa \(1993\)](#). These methods try to assign a marginal utility value to one of a finite set of feasible al-

alternatives over each criterion. Then, techniques are developed to aggregate these marginal utility values. One of the most widely used aggregation approaches is weighted sum modelling (Dyer et al., 1992). The aggregated utility value of an alternative, a real number, represents its relative preference over the other alternatives, and the alternative with higher utility value is preferred by DMs (Wallenius et al., 2008). One representative of value-focused approaches is AHP (Analytic Hierarchy Process), developed by Saaty (1994). This methodology can decompose a decision problem into a hierarchy of more easily comprehensible sub-problems and use pairwise comparisons to gather partial preferences of DMs.

- **Outranking Methods**

The outranking models focus on pairwise comparison of a finite set of alternatives over multiple criteria. Different from value-focused approaches, the output of these methods is not a real number, but an outranking relation. A solution here means that enough arguments can be provided to declare that the option is at least as good as another (Belton and Stewart, 2002). The ELECTRE and PROMETHEE are commonly used outranking methodologies (Roy, 1991; Brans and Mareschal, 2005)

Many other aspects of modern MCDA research, and integrations of MCDA methods with other methodologies need to be mentioned, such as problem structuring techniques (Mingers and Rosenhead, 2004), criteria aggregation models (Damart et al., 2007; Grabisch et al., 2003), robustness analysis (Hites et al., 2006), preference modelling and learning (Fürnkranz and Hüllermeier, 2011), and integration of MCDA with group decision making and negotiation approaches (Belton and Pictet, 1997; Leyva-Lopez and Fernandez-Gonzalez, 2003; Matsatsinis and Samaras, 2001).

Handling uncertainty with reasonable and systematic methodologies has been a prominent topic in MCDA (Zarghami et al., 2011) over the past two decades. At the theoretical level, there have been many surveys of related techniques, such as Chen et al. (1992)'s comprehensive survey of fuzzy discrete MCDA methods; Carlsson and Fullér (1996)'s summary of the development of fuzzy MCDA in the 1990s, focusing on the interdependence of criteria in MCDM; Greco et al. (1999, 2001)'s proposed MCDA procedures related to rough set theory; Ian N. Durbach (2012)'s review of technical tools used in uncertain MCDA and simulation experiment to assess some simplified value function approaches. At the practical level, practitioners applied these approaches in different fields, especially management of natural resources, such as forests (Mendoza and Martins, 2006), water resources (Hyde et al., 2005), and energy (Tylock et al., 2012).

2.2.2 PROMETHEE Modelling

The PROMETHEE (Preference Ranking Organization Method for Enrichment Evaluations), developed by Brans in 1982, is one of the most accepted MCDA methods, and has attracted much attention from academics and practitioners (Brans and Mareschal, 1995, 2005). A multiple criteria outranking methodology, it assists DMs with different perspectives to achieve a consensus on feasible alternatives (Hermans and Erickson, 2007; Machant, 1996), and makes it comparatively easy to rank and prioritize these alternatives over multiple criteria.

The PROMETHEE II method can provide a complete ranking of alternatives based on pairwise comparisons, while PROMETHEE can only give partial ranking of alternatives. Assume that a decision system contains n alternatives $A = \{A_1, A_2, \dots, A_n\}$ and m evaluation criteria $C = \{C_1, C_2, \dots, C_m\}$ for one DM. For $A_p, A_q \in A$, let V_{pk} and V_{qk} denote

the performance of alternatives A_p and A_q , respectively, on criterion k , and let P_k be the DM's selected preference function for criterion k . (For each criterion, six specific preference functions can be used to calculate the preference degree of one alternative over another (Brans et al., 1986).) Then, the DM's preference for alternative A_p over A_q according to criterion k equals $P_k(V_{pk} - V_{qk})$. After that, let w_k represent the DM's assessment of the importance of criterion k , where $\sum_{k=1}^m w_k = 1$.

The relative preference of alternative A_p over A_q across criteria is

$$\pi(A_p, A_q) = \sum_{k=1}^m w_k P_k(V_{pk} - V_{qk}) \quad (2.21)$$

After that, the outflow of V_p , a measure of the preference of alternative A_p over all other alternatives, is defined by

$$\phi^+(A_p) = \frac{1}{n-1} \sum_{\substack{q=1 \\ q \neq p}}^n \pi(A_p, A_q) \quad (2.22)$$

Similarly, the inflow of A_p , a measure of the extent to which A_p is not as good as other alternatives, is denoted by

$$\phi^-(A_p) = \frac{1}{n-1} \sum_{\substack{q=1 \\ q \neq p}}^n \pi(A_q, A_p) \quad (2.23)$$

The evaluation of the net flow of alternative A_p is obtained by subtracting the inflow from the outflow. Usually, alternatives with higher values of net flow are ranked higher.

$$\phi(A_p) = \phi^+(A_p) - \phi^-(A_p) \quad (2.24)$$

The outranking methods of the PROMETHEE family are realistic and flexible, and can be used to model and analyze decision problems with multiple criteria. PROMETHEE II, which provides a complete ranking of a finite set of feasible alternatives, is based on pairwise comparisons of alternatives according to each criterion. The criteria may contain both tangible and intangible information, thereby providing a comprehensive assessment of performance. However, the relative performance of alternatives on qualitative criteria evaluated by DMs may be imprecise, arbitrary, or lack consensus, and the input data on quantitative criteria may be difficult to obtain (Behzadian et al., 2010; Pedrycz et al., 2011). Hence, uncertainty of input values in the PROMETHEE method must be taken into account. Le Teno and Mareschal (1998) put forward an interval version of PROMETHEE method for handling ill-defined information; Goumas and Lygerou (2000) extended the PROMETHEE method for decision making in the form of fuzzy number; Halouani et al. (2009) introduced a 2-tuple linguistic representation model dealing with imprecise information; Li and Li (2010) extended the PROMETHEE II method based on generalized fuzzy numbers, to assess the weights of criteria and the ratings of alternatives; and Hyde et al. (2003) incorporated uncertainty in the PROMETHEE method and proposed a reliability-based approach.

2.3 Conclusions

This chapter begins by systematically reviewing mathematical concepts of grey systems theory, such as grey numbers, the kernel of a grey number, the degree of greyness, grey sets, and grey sequences. A literature review is conducted on methods of grey systems theory, which have been successfully applied to decision problems. A representative technique, grey relational analysis, is presented to determine the preferences of alternatives by

calculating the magnitude of dependence between alternatives and the reference sequence. In the following chapters of the thesis, the fundamental concepts and methods of grey systems theory will be further developed for incorporation into MCDA and GMCR to model decision analysis under uncertainty.

After that, a variety of methodologies and techniques, dealing with choosing, sorting and ranking alternatives in MCDA are summarized and classified. In addition, systematic methodologies for handling uncertainty problems in the field of MCDA over the past two decades are reviewed, and some informative surveys of MCDA techniques are pointed out for further reading. Moreover, a multiple criteria outranking methodology, PROMETHEE II is reviewed, and its theoretical calculation process is discussed. This method will be developed and modified in the following chapter to handle decision problems having both quantitative and qualitative criteria and uncertain information through the integration of grey techniques.

Chapter 3

The Grey-based PROMETHEE II Methodology

3.1 Introduction

The main objective of this chapter is to incorporate grey numbers into Preference Ranking Organization METHod for Enrichment Evaluation II (PROMETHEE II), a multiple criteria outranking methodology. This methodology assists DMs with different perspectives to achieve a consensus on alternatives ranked according to both qualitative and quantitative criteria under uncertainty. This approach uses the concept of grey numbers to represent information that is uncertain or ill-defined, and then combines it with PROMETHEE II. The grey-based PROMETHEE II methodology can produce results that consider the uncertainties associated with vague input data. To help accomplish this objective, this chapter presents the notation, definitions and detailed calculation processes of the grey-based PROMETHEE II methodology. The feasibility and usefulness of the proposed methodol-

ogy is demonstrated using an illustrative case study.

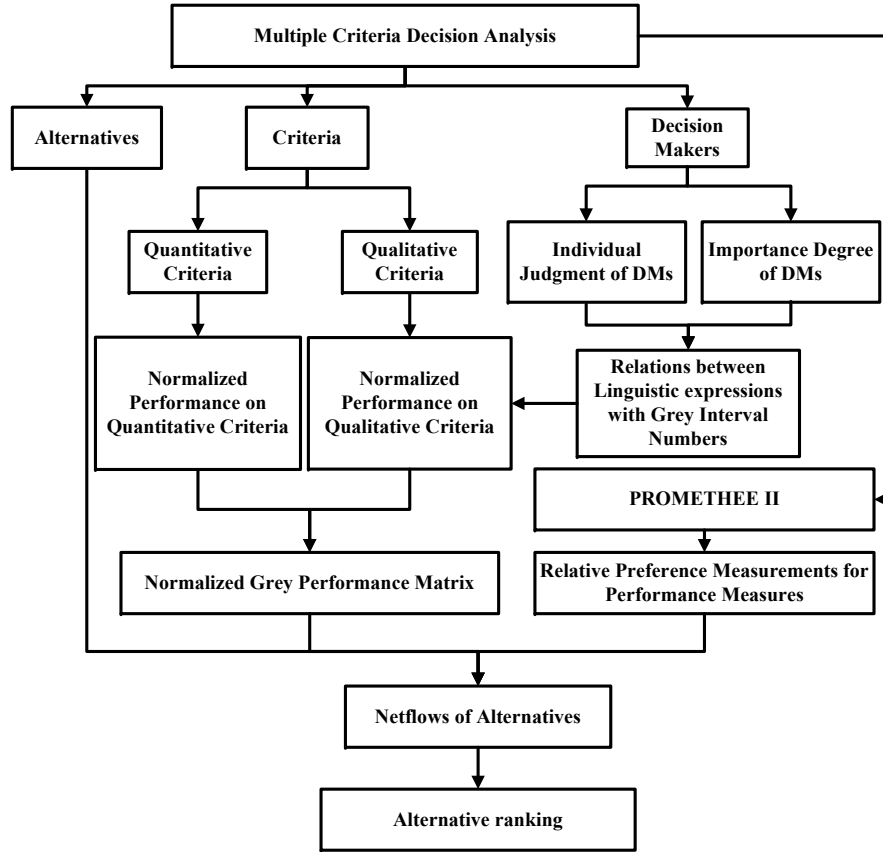

Figure 3.1: Flow Chart of Grey-based PROMETHEE II Methodology

A framework of the grey-based PROMETHEE II methodology is displayed in Figure 3.1. The decision analysis process depends on three main procedures:

- Problem structuring for MCDA with uncertain information. As can be seen near the top of Figure 3.1, the structure contains three main parts: multiple alternatives, criteria and DMs.
- Normalizing the performance of alternatives on multiple criteria. The criteria are

further classified as quantitative or qualitative. Two techniques are employed to normalize the performance of alternatives on these two types of criteria. For quantitative criteria, uncertain input data is used to measure the performance of alternatives; for qualitative criteria, individual judgements of DMs, represented using linguistic expressions are collected to assess the performance of alternatives. After the normalization, a grey performance matrix is generated.

- Ranking alternatives based on the PROMETHEE II methodology. In this research, as one of the main contributions, a relative preference evaluation method is used to measure the preference degree of one alternative over another. This method is incorporated into PROMETHEE II to generate a complete ranking of the alternatives with uncertain information.

3.2 Grey-based PROMETHEE II Methodology

3.2.1 Structure of the Grey Decision System

The main purpose of grey-based PROMETHEE II is to rank alternatives, $A = \{A_1, A_2, \dots, A_n\}$, by DMs, $DM = \{DM_1, DM_2, \dots, DM_L\}$, according to criteria, $C = \{C_1, C_2, \dots, C_m\}$. The decision structure is based mainly on a grey description function and a grey decision system (Kuang et al., 2014d).

Definition 3.1 *Let $A \times C$ be the Cartesian Product of the set of alternatives A and the set of criteria C , and let $G[\mathbb{R}]$ denote the set of all grey numbers. A grey description function*

$$f_{\otimes} : A \times C \rightarrow G[\mathbb{R}] \tag{3.1}$$

describes the performance values of the alternatives on the criteria. For example, for $A_i \in A$ and $C_j \in C$, $f_{\otimes}(A_i, C_j) = \otimes V_{ij}$ is a grey number representing performance of alternative A_i on criterion C_j .

Definition 3.2 Let $A = \{A_1, A_2, \dots, A_n\}$ be a set of n alternatives, $C = \{C_1, C_2, \dots, C_m\}$ be a set of m criteria, $DM = \{DM_1, DM_2, \dots, DM_L\}$ be a decision group that contains L DMs, and let $f_{\otimes} : A \times C \rightarrow G[\mathbb{R}]$ denote a grey description function. A grey decision system is defined as

$$GE = (A, C, DM, f_{\otimes}) \quad (3.2)$$

The decision structure is usually represented using a performance matrix having alternatives as columns, criteria as rows, and performance of alternatives on criteria as the matrix entries. Given a grey description function $f_{\otimes} : A \times C \rightarrow G[\mathbb{R}]$, the performance of the alternative $A_i \in A$ on the criterion $C_j \in C$ is denoted as $\otimes V_{ij} = f_{\otimes}(A_i, C_j)$. In this approach, this performance may be an continuous grey number or a white number. Then an MCDA problem with uncertainty can be represented by Table 3.1. With this representation, each alternative may be represented as a sequence of performance measurements over the criteria. For example, alternative A_i may be represented as $A_i = (\otimes V_{i1}, \otimes V_{i2}, \dots, \otimes V_{im})$.

Table 3.1: Grey-based Decision Structure

		Alternatives					
		A_1	A_2	\dots	A_i	\dots	A_n
Criteria	C_1						
	C_2				\downarrow		
	\dots						
	C_j		\rightarrow		$\otimes V_{ij}$		
	C_m						

3.2.2 Normalizing the Performance of Alternatives

The criteria in a decision problem may be either quantitative or qualitative. This section aims to determine the performance of alternatives according to both types of criteria, and normalize their performance.

This approach considers multiple DMs and is designed to improve the group decision process. When multiple DMs are involved in decision processes, the importance of each DM may be unequal, and sometimes it is necessary to assign different degrees of importance to DMs. In order to determine the importance of each DM in a group decision, French Jr (1956) considered the power relations among members of the group, Keeney and Raiffa (1976) suggested interpersonal comparisons of preferences, and Bodily (1979) introduced a delegation process for setting the weights for DMs. In the proposed methodology, the weight of each DM is voted by the other DMs according to importance, expressed with linguistic information. Then, DMs express their preferences of alternatives based on each qualitative criterion. Both the weights and the preferences are transformed to continuous grey numbers. Note that the performance of alternatives on quantitative criteria is expressed in terms of measured numeric values, which do not depend on DMs' opinions. The normalization measurements of alternatives based on quantitative and qualitative criteria are introduced separately

Quantitative criteria

Quantitative performance measurements can be normalized according to three forms of criteria: increasing, decreasing and targeted. Let $\otimes V_{iq}$, $i = 1, 2, \dots, n$, denote numerical values of alternative i on quantitative criterion q , and let \underline{V}_{iq} and \bar{V}_{iq} represent the lower bound and the upper bound of $\otimes V_{iq}$, respectively. The normalized performance of

alternative i on quantitative criterion q , $\otimes \tilde{V}_{iq}$, is defined as:

- Increasing Criterion: If a larger value of $\otimes V_{iq}$ always indicates better performance of alternative A_i , then

$$\otimes \tilde{V}_{iq} = \frac{\otimes V_{iq} - \min_k \underline{V}_{kq}}{\max_k \bar{V}_{kq} - \min_k \underline{V}_{kq}} \quad (3.3)$$

$$i = 1, 2, \dots, n.$$

- Decreasing Criterion: If a smaller value of $\otimes V_{iq}$ indicates better performance of alternative A_i , then

$$\otimes \tilde{V}_{iq} = \frac{\max_k \bar{V}_{kq} - \otimes V_{iq}}{\max_k \bar{V}_{kq} - \min_k \underline{V}_{kq}} \quad (3.4)$$

$$i = 1, 2, \dots, n.$$

- Targeted Criterion: If a value of $\otimes V_{iq}$ closer to the target value V_q^* indicates better performance of alternative A_i , then

$$\otimes \tilde{V}_{iq} = 1 - \frac{|\otimes V_{iq} - V_q^*|}{\max\{\max_k \bar{V}_{kq} - V_q^*, V_q^* - \min_k \underline{V}_{kq}\}} \quad (3.5)$$

$$i = 1, 2, \dots, n.$$

In (3.5), V_q^* is the target value for the q th criterion, and $\min_k \underline{V}_{kq} \leq V_q^* \leq \max_k \bar{V}_{kq}$.

After normalization, all three types of quantitative criteria have been transformed into increasing criteria, in which a larger value of $\otimes \tilde{V}_{iq}$ indicates better performance of alternative i according to criterion q .

Qualitative criteria

Multiple DMs are considered within a group decision making concept. Different weights are assigned to DMs according to their importance, and linguistic expressions are utilized to represent both the importance of each DM and the performance of alternatives. The performance of alternatives on qualitative criteria is evaluated by DMs, and each DM has his or her own grey-based performance matrix. Qualitative performance measurements should be suitably designed based on increasing criterion, insofar as possible, so that individual judgements of DMs on an alternative can be aggregated according to their importance. Then, one overall matrix reflecting the preferences of all the DMs is produced, and the aggregated matrix is normalized to make the maximum upper bound equal to one. In particular, qualitative performance measurements can be normalized according to the following procedures:

- (1) Normalize the importance degree assigned to each DM.

Definition 3.3 *Let L represent the number of DMs, and $\otimes d^l$ denote the importance degree of DM l . Then, the normalized importance degree of DM l is*

$$\otimes \tilde{d}^l = \frac{\otimes d^l}{\sum_{i=1} \otimes d^i} \quad (3.6)$$

- (2) Evaluate the performance of the alternatives for each DM. Let $\otimes V_{ip}^l$ represent the performance of alternative i on qualitative criterion p given by DM l . The grey-based performance matrix for DM l over qualitative criteria is shown in Table 3.2.

Table 3.2: Grey-based Performance Matrix by DM l on Qualitative Criteria

DM l	Alternatives						
		A_1	A_2	...	A_i	...	A_n
Criteria
	C_p	$\otimes V_{1p}^l$	$\otimes V_{2p}^l$...	$\otimes V_{ip}^l$...	$\otimes V_{np}^l$

(3) Aggregate the performance of alternatives based on qualitative criteria for all decision makers.

Definition 3.4 Let $\otimes V_{ip}^l$ represent the performance of alternative i on qualitative criterion p evaluated by DM l , and $\otimes \tilde{d}^l$ denote the normalized importance degree of DM l . The aggregated performance of alternative i on qualitative criterion p for all DMs is

$$\otimes V_{ip} = [\otimes \tilde{d}^1 \times \otimes V_{ip}^1 + \otimes \tilde{d}^2 \times \otimes V_{ip}^2 + \dots + \otimes \tilde{d}^L \times \otimes V_{ip}^L] \quad (3.7)$$

Note that, in (3.6) and (3.7), there are relationships to map linguistic expressions into grey numbers. In a linguistic approach, the linguistic expressions are used for DMs to express their judgements on alternatives. The linguistic term set can be determined based on the uncertainty degree and a DM's preferences. In a decision process, DMs may respond differently to the same decision context and different linguistic term sets may be chosen by DMs to evaluate the performance of alternatives over qualitative criteria (Chen, 2011; Herrera et al., 2000). This approach allows DMs to use multi-granular linguistic term sets for expressing the linguistic performance of alternatives, and assigning different sets of grey numbers to linguistic information according to DMs' preferences. Therefore, the DMs can

express their judgements in a flexible way. For example, the relationships for $\otimes d^l$ and $\otimes V_{ip}^l$ are shown in Tables 3.3 and 3.4, respectively.

Table 3.3: The Importance Degree of DM l

Scale	$\otimes d^l$
Not important(NI)	[0, 0.3]
Less than moderate(LM)	[0.3, 0.4]
Moderate (M)	[0.4, 0.5]
More than moderate(MM)	[0.5, 0.7]
Important(I)	[0.7, 0.9]
Most important(MI)	[0.9, 1.0]

Table 3.4: Performance of Alternative i on Qualitative Criterion j Evaluated by Decision Maker l

Scale	$\otimes V_{ij}^l$
Low(L)	[0, 0.3]
Less than Moderate(LM)	[0.3, 0.4]
Moderate(M)	[0.4, 0.6]
More than Moderate(MM)	[0.6, 0.7]
High(H)	[0.7, 0.9]
Very high(VH)	[0.9, 1.0]

(4) Normalize performance of alternatives based on qualitative criteria for all DMs

Definition 3.5 Let $\otimes V_{ip} \in [\underline{V}_{ip}, \bar{V}_{ip}]$ represent the aggregated performance of alternative i on qualitative criterion p for all DMs. The normalized performance of alternative i on qualitative criterion p for all DMs is

$$\otimes \tilde{V}_{ip} = \frac{\otimes V_{ip}}{\max_k \tilde{V}_{kp}} \quad (3.8)$$

Normalized performance of alternatives

After completing the above calculation processes, a normalized performance matrix of alternatives according to criteria can be generated as shown in (3.9), which aggregates the information of importance degree of DMs, the individual judgement of DMs on performance of alternatives on qualitative criteria, and the performance of alternatives on quantitative criteria.

$$\otimes \tilde{V} = \begin{bmatrix} \otimes \tilde{V}_{11} & \otimes \tilde{V}_{21} & \dots & \otimes \tilde{V}_{n1} \\ \otimes \tilde{V}_{12} & \otimes \tilde{V}_{22} & \dots & \otimes \tilde{V}_{n2} \\ \dots & \dots & \dots & \dots \\ \otimes \tilde{V}_{1m} & \otimes \tilde{V}_{2m} & \dots & \otimes \tilde{V}_{nm} \end{bmatrix} \quad (3.9)$$

The normalized performance matrix reflects the performance of alternatives on three types of quantitative criteria and viewpoints of all the DMs according to qualitative criteria. It is used as input to an MCDA decision rule for ranking alternatives in group decision making, and PROMETHEE II, a flexible methodology, is further discussed and modified for accomplishing this ranking.

3.2.3 Ranking Alternatives based on PROMETHEE II Methodology

In this section, alternatives are compared in pairs on each criterion. Since performance of alternatives according to criteria may be represented by continuous grey numbers, a new preference function is designed to measure the degree to which one alternative is preferred to another. A multiple criteria preference index is calculated based on the comparison of each pair of alternatives. According to the PROMETHEE II outranking method, the inflow, outflow, and net flow for each alternative are determined separately.

Let two continuous grey numbers $\otimes \tilde{V}_{aj} = [V_{aj}, \bar{V}_{aj}]$ and $\otimes \tilde{V}_{bj} = [V_{bj}, \bar{V}_{bj}]$ represent the performance of alternatives A_a and A_b , respectively, according to criterion j . In particular, when $\otimes \tilde{V}_{aj} = V_{aj} = \bar{V}_{aj} = \tilde{V}_{aj}$ and $\otimes \tilde{V}_{bj} = V_{bj} = \bar{V}_{bj} = \tilde{V}_{bj}$, they represent two white numbers with crisp values.

Definition 3.6 *The deviation of the performance of alternatives A_a from A_b on criterion j is defined by [Xu and Da \(2002\)](#).*

$$d_j(A_a, A_b) = \frac{\bar{V}_{aj} - V_{bj}}{\left| \bar{V}_{aj} - V_{aj} \right| + \left| \bar{V}_{bj} - V_{bj} \right|} \quad (3.10)$$

Thus, $d_j(A_a, A_b)$ measures how much the performance of A_a differs from the performance of A_b on criterion j .

Definition 3.7 *If at least one of $\otimes \tilde{V}_{aj}$ and $\otimes \tilde{V}_{bj}$ is not a white number, the preference*

degree of alternative A_a over A_b on criterion j is defined by

$$\tilde{P}_j(A_a, A_b) = \dots \begin{cases} 0, & \text{if } d_j(A_a, A_b) \leq 0 \\ d_j(A_a, A_b), & \text{if } 0 < d_j(A_a, A_b) < 1 \\ 1, & \text{if } d_j(A_a, A_b) \geq 1 \end{cases} \quad (3.11)$$

From the Definition 3.7, it is clear that $\tilde{P}_j(A_a, A_b)$ is a crisp value and ranges from 0 (no preference) to 1 (strict preference). The preference degree of alternative a over alternative b is interpreted as follows, and shown in Figure 3.2.

If $\tilde{P}_j(A_a, A_b) = 0$, then the performance of alternative A_b is strictly preferred to the performance of A_a according to criterion j ;

If $\tilde{P}_j(A_a, A_b) \in (0, 0.5)$, then the performance of alternative A_a is less likely to be preferred to A_b according to criterion j ;

If $\tilde{P}_j(A_a, A_b) = 0.5$, then the performance of alternatives A_a and A_b is indifferent according to criterion j ;

If $\tilde{P}_j(A_a, A_b) \in (0.5, 1)$, then the performance of alternative A_a is more likely to be preferred to the performance of A_b according to criterion j ;

If $\tilde{P}_j(A_a, A_b) = 1$, then the performance of alternative A_a is strictly preferred to the performance of A_b according to criterion j .

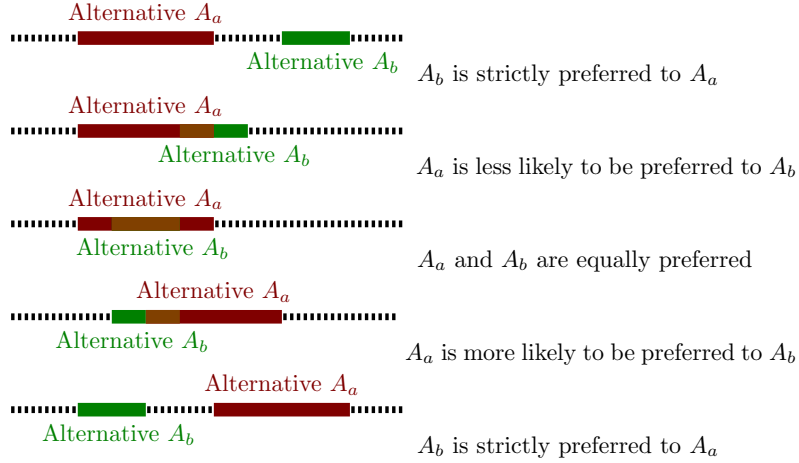

Figure 3.2: The Preference Degree of Alternative a over Alternative b

Definition 3.8 *If both the grey numbers, $\otimes \tilde{V}_{aj}$ and $\otimes \tilde{V}_{bj}$, are white numbers with crisp values, written as \tilde{V}_{aj} and \tilde{V}_{bj} respectively, the preference degree of A_a over A_b is defined by*

$$\tilde{P}_j(A_a, A_b) = \dots \begin{cases} 0, & \text{if } \tilde{V}_{aj} < \tilde{V}_{bj} \\ 0.5, & \text{if } \tilde{V}_{aj} = \tilde{V}_{bj} \\ 1, & \text{if } \tilde{V}_{aj} > \tilde{V}_{bj} \end{cases} \quad (3.12)$$

This is a special case of the comparison of two continuous grey numbers. The values 0, 0.5 and 1 represent not preferred, indifferent, and strictly preferred of A_a over A_b on criterion j , respectively.

It is assumed that DMs can assign weights to all criteria, especially when the number of criteria is not too large. The weights for the criteria considered here are additive. For instance, if w_1, w_2, \dots, w_m represent the weights of criteria C_1, C_2, \dots, C_m respectively,

then $\sum_{j=1}^m w_j = 1$. The relative preference of alternative A_a over A_b evaluated on all criteria is defined below.

Definition 3.9 Let w_1, w_2, \dots, w_m denote weights of criteria C_1, C_2, \dots, C_m , respectively, and $\tilde{P}_j(A_a, A_b)$ represent the preference degree of alternative A_a over A_b on criterion j . The relative preference of A_a over A_b , evaluated over all criteria, is

$$\tilde{\pi}(A_a, A_b) = \sum_{j=1}^m \tilde{P}_j(A_a, A_b)w_j \quad (3.13)$$

After the relative preferences have been calculated for each pair of alternatives, the alternatives can be ranked based on the values of the netflow $\tilde{\phi}(A_p)$ obtained by measuring the intensity of preference of one alternative over all the others. An alternative with higher value of netflow is ranked higher.

Definition 3.10 Let $\tilde{\phi}^+(A_a)$ represent the outflow of A_a , a measure of the preference for alternative A_a over all the other alternatives; $\tilde{\phi}^-(A_a)$ represent the inflow of A_a , a measure of preference for the other alternatives, as a group, over alternative A_a . The netflow of A_a is defined by:

$$\begin{aligned} \tilde{\phi}(A_a) &= \tilde{\phi}^+(A_a) - \tilde{\phi}^-(A_b) \\ &= \frac{1}{n-1} \sum_{\substack{b=1 \\ b \neq a}}^n \tilde{\pi}(A_a, A_b) - \frac{1}{n-1} \sum_{\substack{b=1 \\ b \neq a}}^n \tilde{\pi}(A_b, A_a) \end{aligned} \quad (3.14)$$

3.3 Case illustration of Evaluation of Source Water Protection Strategies

In this section, the preference function for measuring preferences of alternative represented by grey numbers and the proposed grey-based PROMETHEE II method are used for analyzing the case study in order to rank the alternatives.

3.3.1 Background

As an issue, source water protection is gaining increasing global attention, along with economic development, population growth and water scarcity (Patrick, 2011). Responding to the challenges having access to safe drinking water, many projects have been conducted for ensuring water quality, remediating water contamination, and minimizing potential threats to surface and groundwater resources (Ferreyra, 2012; Emelko et al., 2011; Qin et al., 2009).

The Regional Municipality of Waterloo, located in the southwestern part of Ontario, Canada, is comprised of Kitchener, Waterloo, and Cambridge, as well as adjacent townships. The residents in Waterloo Region access to their drinking water from three main sources: (i) almost 69 percent is from groundwater through more than 100 municipal wells; (ii) 28 percent comes from the Grand River; and (iii) the last 3 percent is from the Great Lakes. In developing its long-term water strategy of ensuring that citizens can enjoy plentiful and clean drinking water, the Regional Municipality of Waterloo received various proposals. Therefore, a scientific evaluation system needs to be designed to prioritize or rank these strategies. The case study is sourced from a technical report entitled “Regional Municipality of Waterloo Long Term Water Strategy—Phase 1 Report”. The data in this

research was simulated, in a manner that is consistent with this report, to demonstrate the feasibility of this methodology for the MCDA problem having uncertain information ([Regional Municipality of Waterloo and Water Services Division, 1994](#); [Region of Waterloo, 2000](#)).

Since 1993, a number of strategies have been successfully conducted by the Regional Municipality of Waterloo to implement source water protection for its water supply system ([Region of Waterloo, 2008](#)), and eight strategies have been selected as alternatives for this case study ([Kuang et al., 2012](#)):

- Alternative 1 (A-1): Installation of sentry wells or off-site monitoring wells
- Alternative 2 (A-2): Strategic land purchase and/or easement
- Alternative 3 (A-3): Chemical restriction by municipal law
- Alternative 4 (A-4): Buy-back of contaminated or at-risk land
- Alternative 5 (A-5): Regulation of bulk fuel, retail and accessory use of gasoline
- Alternative 6 (A-6): Replacement of underground diesel fuel storage tanks with above ground tanks and containment units
- Alternative 7 (A-7): Smart salt project
- Alternative 8 (A-8): Decommissioning and upgrading of wells

With the purpose of providing an overall evaluation on performance of alternatives, this evaluation system must take account of various kinds of criteria from different perspective, such as economic development, political and social influence, and ecological maintenance.

Four criteria are proposed to evaluate possible alternatives. The meaning of the criteria are explained in details as follows (Chen et al., 2007; Rajabi et al., 2001):

- INVEST: project investment cost (millions of dollars);
- OPER: projection operating cost (millions of dollars) ;
- RISKD: the alternative’s ability to decrease water quantity and quality risks to water resources from historical, existing or future practices (Region of Waterloo, Jan, 2008);
- FEAS: technical, operational, law and public feasibility (Rajabi et al., 2001).

Note that INVEST and OPER are quantitative criteria, while RISKD and FEAS are qualitative criteria.

3.3.2 Input Data

Assume that the illustrative case contains three DMs, DM1, DM2 and DM3. The simulated input data includes importance degrees of DMs, weights of criteria, performance of source water protection strategies on qualitative criteria, and performance of source water protection strategies on quantitative criteria, as shown in Tables 3.5-3.8

Table 3.5: Importance Degrees of Decision Makers

DMs	DM 1	DM 2	DM 3
Importance Degrees of DMs	MM	MI	I

Note that the maps between linguistic expressions and grey numbers are provided in Tables 3.3 and 3.4 on page 40.

Table 3.6: Weights of Criteria

Criteria	RISKD	FEAS	INVEST	OPER
Weights	0.3	0.2	0.3	0.2

Table 3.7: Performance of Source Water Protection Strategies on Qualitative Criteria

	DM 1		DM 2		DM 3	
	RISKD	FEAS	RISKD	FEAS	RISKD	FEAS
A-1	H	VH	MM	VH	H	H
A-2	VH	M	H	LM	H	H
A-3	MM	H	M	VH	H	VH
A-4	H	VH	H	H	MM	H
A-5	VH	H	VH	H	H	VH
A-6	H	MM	VH	VH	VH	LM
A-7	LM	VH	M	H	M	LM
A-8	H	H	LM	MM	M	MM

Table 3.8: Performance of Source Water Protection Strategies on Quantitative Criteria

Alternatives	A-1	A-2	A-3	A-4	A-5	A-6	A-7	A-8
INVEST	[14,20]	35	[8,15]	25	3	12	10	[18,23]
OPER	[4,7]	1	[4,7]	0.5	15	14	6	[5,7]

3.3.3 Normalization of the Performance of Alternatives

According to the input data listed above, the performance of alternatives over both quantitative and qualitative criteria can be normalized.

- For quantitative criteria: INVEST and OPER are decreasing criteria that can be normalized based on (3.4), and the results are shown in Table 3.10.
- For qualitative criteria: The normalized importance degrees of DMs can be calculated based on (3.6), and the normalized performance of alternatives over RISKD FEAS can be generated based on (3.8). The results are shown in Tables 3.9 and 3.10. Note that the process of normalization depends on the addition and division of grey numbers given in (2.4) and (2.7), respectively, and creates some overlap of the normalized importance degrees of the DMs.

Table 3.9: Normalized Importance Degrees of Decision Makers

DMs	DM 1	DM 2	DM 3
Importance Degrees of DMs	[0.5 – 0.7]	[0.9 – 1.0]	[0.7 – 0.9]
Normalized Importance Degrees of DMs	[0.19 – 0.33]	[0.35 – 0.39]	[0.27 – 0.43]

Table 3.10: Normalized Performance of Alternatives on Criteria

Criteria	INVEST	OPER	RISKD	FEAS
Alternative 1	[0.47,0.66]	[0.55,0.76]	[0.48,0.86]	[0.60,0.99]
Alternative 2	0	0.97	[0.54,0.96]	[0.33,0.66]
Alternative 3	[0.63,0.84]	[0.55,0.76]	[0.40,0.76]	[0.62,0.1]
Alternative 4	0.31	1	[0.48,0.85]	[0.54,0.96]
Alternative 5	1	0	[0.60,0.99]	[0.56,0.97]
Alternative 6	0.72	0.14	[0.62,1]	[0.46,0.71]
Alternative 7	0.78	0.62	[0.27,0.56]	[0.44,0.76]
Alternative 8	[0.38,0.53]	[0.55,0.69]	[0.31,0.64]	[0.45,0.78]

3.3.4 Results and Analysis

Based on the input data and normalized performance of alternatives, a pairwise comparison of all strategies is conducted according to each criterion. Then, a multiple criteria preference matrix based on the comparison of each pair of source water protection strategies over the criteria of RISKD, FEAS, INVEST, and OPERI is formed according to the designed preference function, see (3.10-3.12). The results are shown in Table 3.11

Table 3.11: Multiple Criteria Preference Matrix

		A-1	A-2	A-3	A-4	A-5	A-6	A-7	A-8
A-1	INVEST	0.50	1.00	0.08	1.00	0.00	0.00	0.00	0.82
	OPER	0.50	0.00	0.50	0.00	1.00	1.00	0.67	0.60
	RISKD	0.50	0.40	0.62	0.50	0.33	0.31	0.88	0.77
	FEAS	0.50	0.92	0.48	0.56	0.55	0.83	0.77	0.75
A-2	INVEST	0.00	0.50	0.00	0.00	0.00	0.00	0.00	0.00
	OPER	1.00	0.50	1.00	0.00	1.00	1.00	1.00	1.00
	RISKD	0.60	0.50	0.72	0.61	0.44	0.42	0.98	0.87
	FEAS	0.08	0.50	0.06	0.16	0.14	0.35	0.34	0.32
A-3	INVEST	0.92	1.00	0.50	1.00	0.00	0.57	0.29	1.00
	OPER	0.50	0.00	0.50	0.00	1.00	1.00	0.67	0.60
	RISKD	0.38	0.28	0.50	0.38	0.21	0.19	0.75	0.65
	FEAS	0.52	0.94	0.50	0.58	0.56	0.86	0.79	0.77
A-4	INVEST	0.00	1.00	0.00	0.50	0.00	0.00	0.00	0.00
	OPER	2.17	1.00	1.00	0.50	1.00	1.00	1.00	1.00
	RISKD	0.50	0.39	0.62	0.50	0.33	0.31	0.88	0.78
	FEAS	0.44	0.84	0.42	0.50	0.49	0.75	0.70	0.68
A-5	INVEST	1.00	1.00	1.00	1.00	0.50	1.00	1.00	1.00
	OPER	0.00	0.00	0.00	0.00	0.50	0.00	0.00	0.00
	RISKD	0.67	0.56	0.79	0.67	0.50	0.48	1.00	0.95
	FEAS	0.45	0.86	0.44	0.51	0.50	0.77	0.71	0.70
A-6	INVEST	1.00	1.00	0.43	1.00	0.00	0.50	0.00	1.00
	OPER	0.00	0.00	0.00	0.00	1.00	0.50	0.00	0.00
	RISKD	0.69	0.58	0.81	0.69	0.52	0.50	1.00	0.97
	FEAS	0.17	0.65	0.14	0.25	0.23	0.50	0.46	0.44
A-7	INVEST	1.00	1.00	0.71	1.00	0.00	1.00	0.50	1.00
	OPER	0.33	0.00	0.33	0.00	1.00	1.00	0.50	0.50
	RISKD	0.12	0.02	0.25	0.12	0.00	0.00	0.50	0.41
	FEAS	0.23	0.66	0.21	0.30	0.29	0.54	0.50	0.48
A-8	INVEST	0.18	1.00	0.00	1.00	0.00	0.00	0.00	0.50
	OPER	0.40	0.00	0.40	0.00	1.00	1.00	0.50	0.50
	RISKD	0.23	0.13	0.35	0.22	0.05	0.03	0.59	0.50
	FEAS	0.25	0.68	0.23	0.32	0.30	0.56	0.52	0.50

Subsequent to calculation of the relative preference for each pair of alternatives considering all criteria, the netflow that measures the relative preference of one alternative over all the others is generated according to (3.13-3.14), and the results is shown in Table 3.12.

Table 3.12: Netflow of Alternatives

	A-1	A-2	A-3	A-4	A-5	A-6	A-7	A-8
A-1	0.50	0.60	0.40	0.56	0.41	0.46	0.55	0.75
A-2	0.40	0.50	0.43	0.21	0.36	0.40	0.56	0.53
A-3	0.60	0.57	0.50	0.53	0.38	0.60	0.60	0.77
A-4	0.67	0.79	0.47	0.50	0.39	0.44	0.60	0.57
A-5	0.59	0.64	0.62	0.61	0.50	0.60	0.74	0.73
A-6	0.54	0.60	0.40	0.56	0.40	0.50	0.39	0.68
A-7	0.45	0.44	0.40	0.40	0.26	0.61	0.50	0.62
A-8	0.25	0.47	0.23	0.43	0.27	0.32	0.38	0.50
Outflow	0.53	0.41	0.58	0.56	0.65	0.51	0.45	0.34
Inflow	0.57	0.66	0.49	0.54	0.42	0.56	0.62	0.73
Netflow	-0.04	-0.25	0.08	0.02	0.22	-0.05	-0.17	-0.40

Finally, a complete ranking order of eight source water protection strategies is calculated based on the netflow of each alternative. An alternative with a higher value is preferred.

$$A-5 \succ A-3 \succ A-4 \succ A-1 \succ A-6 \succ A-7 \succ A-2 \succ A-8.$$

As can be seen from the above results, alternative 5 is the most preferred alternative, while alternative 8 is the least preferred according to performance on both quantitative and qualitative criteria. With positive values, alternatives 5, 3, and 4 are better than the other alternatives.

3.4 Conclusions

The proposed methodology extends the PROMETHEE II method to deal with ill-defined information. A performance matrix is defined for evaluating alternatives, according to both quantitative and qualitative criteria, across all DMs. Uncertainty of input values in the PROMETHEE II method is taken into account, and continuous grey numbers are integrated with linguistic expressions to represent both the importance degree of each DM and the performance of alternatives.

Detailed calculation procedures for normalization are provided. The quantitative performance measurements are normalized based on three types of criteria: increasing, decreasing and targeted. As performance data for alternatives may be uncertain, this method allows continuous grey numbers to represent the input data. The qualitative performance measurements are taken into account in the group decision, and mutual voting is used to assign different weights to DMs according to their importance. The performance of alternatives is separately evaluated by each DM and, finally, individual judgements of all DMs are aggregated and normalized.

As the normalized performance matrix contains uncertain information represented by continuous grey numbers, a new preference function is developed for PROMETHEE II to compare alternatives in a pairwise fashion on each criterion and, subsequently, to order the alternatives. This preference function measures the preference degree of one alternative over another. Compared with the original six types of preference functions, it is more suitable for application to real cases where input data are similar but not identical.

MCDA methods are designed for handling certain types of decision situations. Compared with other MCDA techniques, the grey-based PROMETHEE II methodology presented in this chapter can: *(i)* represent ill-defined information with grey numbers; *(ii)*

simultaneously handle quantitative and qualitative criteria; *(iii)* incorporate a preference measurement function into PROMETHEE II; and *(iv)* deal with multiple criteria and a group decision through aggregating individual decisions. The numerical case study shows the suitability of the methodology to handle multi-criteria decisions with uncertain information, and illustrates its potential applicability.

Chapter 4

The Graph Model for Conflict Resolution

4.1 Introduction

In this chapter, theoretical definitions of Graph Model for Conflict Resolution (GMCR) are presented, and solutions concepts (or stability definitions) are provided for carrying out a stability analysis for a conflict with two or more DMs. After that, this methodology is used for analyzing a conflict involving water use and oils sands development in the Athabasca River in Alberta, Canada. In the case study, stable states are calculated, and strategic interpretations of the stability results are provided.

The main purpose of the graph model methodology is to describe the key characteristics of a conflict based on the possible interactions of DMs as dictated by their strategies and preferences, and then generate the possible compromise resolutions, or equilibria, through extensive analyses ([Hipel et al., 1997](#)). Within the graph model paradigm, a conflict model

requires four main components: (i) a set of DMs, (ii) a set of feasible states, (iii) possible movements between states controlled by each DM, and (iv) each DM's relative preference over the feasible states (Fang et al., 1993; Hamouda et al., 2004). In general, if a DM has no incentive to move from the present state, this state is stable for the DM. If a state is stable for all DMs, it constitutes an equilibrium of the model. The main stability definitions included in the graph model are Nash stability (R) (Nash, 1950), general metarationality (GMR) (Howard, 1971), symmetric metarationality (SMR) (Howard, 1971), and sequential stability (SEQ) (Fraser and Hipel, 1984). These stability definitions describe possible moves and countermoves representing common patterns of human behaviours.

4.2 Theoretical Foundations of the Graph Model for Conflict Resolution

The graph model methodology represents possible scenarios (or states) of a conflict as vertices of a graph, and the transitions controlled by each DM as the arcs of the graph, labelled by the DM controlling a given move in one step. Note that, in a graph model, the movements of DMs can be reversible or irreversible, and no loops are contained in any DM's graph. To formally model a conflict, the four fundamental components of GMCR mentioned above are mathematically expressed as follows (Fang et al., 1993; Hipel et al., 1997; Kilgour and Hipel, 2005):

- $N = \{1, 2, \dots, n\}$, $n \geq 2$, represents the set of DMs. For the case of two DMs, $N = \{1, 2\}$.
- $S = \{s_1, s_2, \dots, s_m\}$, $m > 1$, denotes the set of feasible states. The particular state where the conflict begins is designated as the status quo state.

- For $k \in N$, $G_k = (S, A_k)$ denotes DM k 's directed graph. Here, $A_k \subseteq S \times S$ represents the set of arcs controlled by DM k . For example, for $s_i, s_j \in S$ and $s_i \neq s_j$, $(s_i, s_j) \in A_k$ if and only if DM k can unilaterally move the conflict from state s_i to state s_j in one step. In this case, state s_j is reachable from state s_i for DM k . Then, the collection of the directed graphs of all the DMs, $G = \{(S, A_k), k \in N\}$, can be convincingly used to model the conflict.
- For $k \in N$, a binary relation $\{\succ_k, \sim_k\}$ on S expresses DM k 's preference of one state over another. Specifically, for $s_i, s_j \in S$, $s_i \succ_k s_j$ indicates that s_i is strictly preferred to s_j by DM k , while $s_i \sim_k s_j$ means that s_i is equally preferred to s_j .

To formally define the previously mentioned four major stability concepts within the graph model framework, one needs to identify states that are unilaterally reachable by a DM. Accordingly, the definitions of reachable list and the unilateral improvement list are given below (Fang et al., 1993, 2003a; Hipel et al., 1997).

Definition 4.1 *The Reachable list for a DM* Let $k \in N$ and $s \in S$. The reachable list from state s for DM k is

$$R_k(s) = \{s_i \in S : (s, s_i) \in A_k\}. \quad (4.1)$$

Note that the reachable list from a given state for a DM represents a collection of all possible states to which the DM can move in one step.

Definition 4.2 *The Unilateral Improvement List for a DM* Let $k \in N$ and $s \in S$. The unilateral improvement list from state s for DM k is

$$R_k^+(s) = \{s_i \in R_k(s) : s_i \succ_k s\}. \quad (4.2)$$

Note that the unilateral improvement list from a given state for a DM is the collection of all preferred states, compared with the given state, to which the DM can unilaterally move.

For a conflict involving more than two DMs, it is necessary to define coordinated moves. The reachable list for multiple DMs from a given state represents a collection of all possible states to which some or all of the DMs can move via a legal sequence of moves, in which the same DM may move more than once, but not twice consecutively.

Definition 4.3 *The Reachable List for Multiple DMs* Let $s \in S$, $H \subseteq N$ and $|H| \geq 2$. Let $\Omega_H(s, s_i)$ denote the set of all last DMs in legal sequences of unilateral moves from s to s_i . The reachable list $R_H(s)$ for H from state s is defined inductively as

- (1) if $k \in H$ and $s_1 \in R_k(s)$, then $s_1 \in R_H(s)$ and $k \in \Omega_H(s, s_1)$.
- (2) if $s_1 \in R_H(s)$, $k \in H$, $s_2 \in R_k(s_1)$, and $\Omega_H(s, s_1) \neq \{k\}$, then $s_2 \in R_H(s)$ and $k \in \Omega_H(s, s_2)$.

Note that the definition stops only when no new state can be added to $R_H(s)$. The unilateral movement list is the collection of all unilateral movements for any non-empty subset of the DMs from the given state.

Definition 4.4 *Unilateral Improvement List for Multiple DMs* Let $s \in S$, $H \subseteq N$ and $|H| \geq 2$. Let $\Omega_H^+(s, s_i)$ denote the set of all last DMs in legal sequences allowable for implementing a unilateral improvement from s to s_i . Then, the unilateral improvement(s) list $R_H^+(s)$ from state s for H is defined inductively as

- (1) if $k \in H$, and $s_1 \in R_k^+(s)$, then $s_1 \in R_H^+(s)$ and $k \in \Omega_H^+(s, s_1)$
- (2) if $s_1 \in R_H^+(s)$, $k \in H$, $s_2 \in R_k^+(s_1)$, and $\Omega_H^+(s, s_1) \neq \{k\}$, then $s_2 \in R_H^+(s)$ and $k \in \Omega_H^+(s, s_2)$

Keep in mind that the definition stops only when there is no more new state. A joint unilateral improvement from a given state by a subset of at least two DMs is a state that is in the reachable list for these DMs from the initial state and worthwhile for all of them.

Example 4.1 *If a group of DMs, H , moves the conflict from state s_1 to s_2 via a legal sequence of moves and each movement is a unilateral improvement for one DM, then s_2 is a unilateral improvement for H , as are the intermediate states. The unilateral improvement list is the collection of all unilateral improvements from the given state for any non-empty subset of the DMs.*

4.3 Stability Analysis in a Conflict with Two Decision Makers

In GMCR, if the focal DM has no incentive to move from an initial state, this state is stable for him. Stability definitions (or solution concepts) were introduced to identify such states (Kilgour and Hipel, 2005). Let $N = \{p, q\}$ represents the set of DMs in a conflict having two DMs, given by p and q . Then, a brief summary of the four stability definitions mentioned above in a 2-DM conflict within the framework of graph model is presented as follows (Fang et al., 1993, 2003a; Hipel et al., 1997):

Definition 4.5 Nash Stability (R) *A state $s \in S$ is Nash stable for DM p , denoted by $s \in S_p^R$, if and only if $R_p^+(s) = \emptyset$.*

From a Nash stable state, the focal DM has no unilateral improvement to which to move. Thus, from a given state, if there is a unilateral improvement, the DM will move to it.

For this stability type, the focal DM does not take into account possible responses by his opponent. However, a DM may consider possible countermoves if he moves to an advantageous state. The next three definitions characterize rules to identify stable states for a DM with foresight.

Definition 4.6 *General Metarationality (GMR)* A state $s \in S$ is general metarational for DM p , denoted by $s \in S_p^{GMR}$, if and only if for every $s_1 \in R_p^+(s)$ there exists at least one $s_2 \in R_q(s_1)$ such that $s_2 \succsim s$.

In general metarational stability, it is assumed that any unilateral improvement from the initial state for the focal DM can be sanctioned by a subsequent unilateral movement by the other DM. In this situation, the initial state is general metarational stable.

Definition 4.7 *Symmetric Metarationality (SMR)* A state $s \in S$ is symmetric metarational stable for DM p , denoted by $s \in S_p^{SMR}$, if and only if for every $s_1 \in R_p^+(s)$ there exists at least one $s_2 \in R_q(s_1)$ such that $s_2 \succsim s$, and $s_3 \succsim s$ for all $s_3 \in R_p(s_2)$.

In symmetric metarational stability, any unilateral improvement for the focal DM from the initial state can be sanctioned by a subsequent unilateral movement by the other DM, and the focal DM cannot escape the sanction through another countermove. In this case, the initial state is symmetric metarationality.

Definition 4.8 *Sequential Stability (SEQ)* A state $s \in S$ is sequentially stable for DM p , denoted by $s \in S_p^{SEQ}$, if and only if for every $s_1 \in R_p^+(s)$ there exists at least one $s_2 \in R_q^+(s_1)$ such that $s_2 \succsim s$.

The definition of sequential stability is the same as general metarational stability except that while considering the sanction of the focal DM's unilateral improvement imposed by the opponent, the focal DM only takes into account the opponent's unilateral improvements rather than unilateral movements.

4.4 Stability Analysis in a Conflict with Multiple Decision Makers

In a conflict with more than two DMs, the opponent of a focal DM is a group (or coalition) of DMs. Taking into account possible subsequent movements of the group of other DMs, if the focal DM has no initiative to move from an initial state, this state is stable for him or her. Stability definitions (or solution concepts) are introduced to identify such states (Kilgour and Hipel, 2005). Assume that $S = \{s_1, s_2, \dots, s_m\}$, $m > 1$ denotes the set of feasible states, and N represents the set of DMs. Then, a brief summary of four stability definitions in a n -DM ($n \geq 2$) conflict is presented as follows (Fang et al., 2003a; Hipel et al., 1997):

Definition 4.9 Nash Stability (R) for multiple DMs Let $k \in N$, a state $s \in S$ is Nash stable or rational for DM k , denoted by $s \in S_p^R$, if and only if $R_k^+(s) = \emptyset$.

For a Nash stable state, the focal DM has no unilateral improvement from the initial state. The definition is the same as the model with two DMs.

Definition 4.10 General Metarationality (GMR) for multiple DMs Let $k \in N$, and $N - \{k\}$ denote all the other DMs except k . A state $s \in S$ is general metarational for

DM k , denoted by $s \in S_k^{GMR}$, if and only if for every $s_1 \in R_k^+(s)$ there exists at least one $s_2 \in R_{N-\{k\}}(s_1)$ such that $s_2 \succsim s$.

Definition 4.11 Symmetric Metarationality (SMR) for multiple DMs Let $k \in N$, and $N - \{k\}$ denote all the other DMs except k . A state $s \in S$ is symmetric metarational stable for DM k , denoted by $s \in S_k^{SMR}$, if and only if for every $s_1 \in R_k^+(s)$ there exists at least one $s_2 \in R_{N-\{k\}}(s_1)$ such that $s_2 \succsim s$, and $s_3 \succsim s$ for all $s_3 \in R_k(s_2)$.

Definition 4.12 Sequential Stability (SEQ) for multiple DMs Let $k \in N$, and $N - \{k\}$ denote all the other DMs except k . A state $s \in S$ is sequentially stable for DM k , denoted by $s \in S_k^{SEQ}$, if and only if for every $s_1 \in R_k^+(s)$ there exists at least one $s_2 \in R_{N-\{k\}}^+(s_1)$ such that $s_2 \succsim s$.

The four stability definitions for an n -decision Maker ($n \geq 2$) graph model provided above are similar to the respective definitions introduced in subsection 4.3. The only difference is that opponents of the focal DM are multiple DMs. In considering moving to possible unilateral improvements, the focal DM needs to take account of sanctions, which can be imposed by multiple DMs through unilateral movements or unilateral improvements rather than countermoves by a single opponent.

4.5 Case Study: Conflict Analysis on Water Use and Oil Sands Development in the Athabasca River

4.5.1 Background

On September 25th, 2010, Mr. Rob Renner, Alberta's Environment Minister stated: *“Understanding the impact of the oil sands industry on the watershed of north-eastern Alberta is absolutely critical. We need to have total and complete assurance in data before we make decisions on how best to balance environmental protection with development. Albertans deserve to have this assurance as well (Renner, 2010).”*

Oil sands are a naturally occurring mixture of sand, clay, water and bitumen. As a kind of petroleum that exists in the semi-solid or solid phase in natural deposits, it must be upgraded before being refined to produce consumer products like gasoline (Government of Alberta, 2008). The oil sands, located in northern Alberta, Canada, constitute one of the largest oil deposits with proven reserves of 167.9 billion barrels of bitumen (Alberta Department of Energy, 2013).

Oil sands production mainly consists of two technologies: a mining technology and in-situ technology (Alberta Department of Energy, 2013). Both mining and in-situ operations require a great quantity of water in order to extract bitumen. About 3.1 barrels of water are used to produce each barrel of synthetic crude oil (SCO) by mining operations; 2.6 of them are withdrawn from the Athabasca Rivier. In-situ technology has greatly reduced water consumption, resulting in about 0.4 barrels of water consumption per barrel of SCO (Canadian Association of Petroleum Producers, 2012). Nevertheless, compared with 0.1 to 0.3 barrels of water consumption per barrel for the production of conventional oil (IFP Energies Nouvelles, 2011), the water consumption in the oil sands industry is considerable.

In 2011, approved oil sands mining projects were licensed to divert 117 million cubic metres of fresh water from the Athabasca River, and the quantity of fresh water used was increased to approximately 187 million cubic metres in 2012. This water use constitutes 0.6% of the average annual flow and less than 3% of the lowest weekly winter river flow ([Canadian Association of Petroleum Producers, 2013](#)). Despite some recycling, almost all of the water withdrawn for oil sands operations ends up in tailings ponds.

The oil sands industry definitely accelerates economic development coupled with more employment opportunities, and increasing tax income for the local government. The oil sands industry is expanding at a high speed. As of 2010, about 75,000 jobs were directly or indirectly related to the construction and operation of the oil sands industry. It is predicted that over the next 25 years, \$2.1 trillion will be generated in economic activity across Canada by oil sands development, and at least \$783 billion in royalties and tax revenues will be paid to Canada's federal and provincial governments ([Canadian Association of Petroleum Producers, 2013](#)).

There are many aspects of the development of the oil sands industry which could have negative effects on the environment. Among them, the great quantity of water consumed in the oil sands operations is one of the most important concerns, because an insufficient water supply to downstream areas and inappropriate waste water disposal can have serious effects on local fresh water resources ([Humphries, 2008](#)). The report of "Down to the Last Drop: the Athabasca River and Oil Sands" by the Pembina Institute, stated that the plan released by Alberta Environment for managing water withdrawals from the Athabasca River cannot protect the river from long-term ecological impacts ([Woynillowicz and Severson-Baker, 2006](#)). Tony Maas put forward his opinion that the existing water management framework does not provide sufficient protection for the aquatic ecosystem of the Athabasca River ([Maas, 2009](#)).

Because it will bring high economic benefits to some stakeholders, the future development of the oil sands may be inevitable. Therefore, conflicts between the oil sands industry and other interested parties over water scarcity are unavoidable. These problems must be adequately addressed. In this section, the conflict of water use and oil sands development in the Athabasca River Basin will be modelled and analyzed using a decision support methodology, called the graph model for conflict resolution. Stability analysis will be carried out, and associated strategic insights will be provided (Kuang et al., 2014c).

4.5.2 Water Use and Oil Sands Development Conflict in the Athabasca River Basin

The Athabasca River is the longest river running through Alberta, and fresh water in the Athabasca River is used by the oil sands industry as well as by local communities. Faced the conflict over the development of the oil sands industry and associated water scarcity, the Alberta Government and Fisheries and Oceans Canada jointly created the Alberta River Water Management Framework with the purpose of balancing the needs of the community and oil sands operations. The Framework has two Phases (Alberta Environment and Fisheries and Oceans Canada, 2007):

- Phase I proposed three management zones (green, yellow and red) according to the flow conditions within the river, so as to control the water withdrawals of oil sands operators. Currently, oil sands operators must comply with Oil Sands Water Management Agreement for the 2014 Winter Period which was signed in November 2013. This means that each oil sands company can only withdraw a limited quantity of water from the Athabasca River under the restrictions of the agreement (Alberta Environment and Fisheries and Oceans Canada, 2013).

- Phase II will determine the required modifications to Phase I, based on a review and adaptive management process to achieve environmental and socio-economic goals over the long-term, taking into account current scientific knowledge and professional judgement. Consequently, a more restrictive withdrawal regime would be set up to ensure the aquatic ecosystem remains protected into the future.

In this generic conflict representing a typical oil sands dispute, three main decision makers are considered: the Alberta government, oil sands companies, and Non-Government Organizations (NGOs). Each DM holds different attitudes and options. The details are explained as follows.

(1) The Alberta Government

The oil sands have made a great contribution to the economic development of Alberta during the past 10 years, and offer a robust economic future. Between 1971 and 2013, the oil and gas industry in Alberta was enormously successful, contributing a lot to labour income and in government revenue. Hence, the Alberta Government is a stakeholder that would benefit greatly from oil sands development. However, water is not only a resource, but also one of the most significant elements for human beings. The government must protect aquatic ecosystems during the rapid development of the oil sands industry. The Alberta Government has two main options: one is to provide extra funding and cooperate with NGOs; this could effectively promote research and technology in the oil sands industry, and improve the efficiency of fresh water use for oil sands operations. The other is to put more stringent restrictions on the water use in the Alberta River Water Management Framework (Phase II). Then oil sands companies would have to increase their investment in order to reduce the water demand. Moreover, some of them may choose to withdraw from the oil sands markets. This option may somewhat influence oil sands development,

so it is less preferred than the first option for the Alberta Government.

(2) Oil Sands Companies

It is expected that oil sands industry in Alberta has a profitable future. However, issues and uncertainties always exist in a changing world. The oil sands companies must take into account all factors that can affect their benefits, including oil prices, investment climate, global oil demand, new technology, and access to other markets. At the same time, water use, air emissions, local infrastructure and services, labour requirements, natural gas costs and the light/heavy oil price differentials are factors that could inhibit the development of the resource. The requirements of the Alberta River Water Management Framework on water use may become more stringent, and the Alberta Government and NGOs are paying more attention to the protection of the Alberta river ecosystem. Hence, oil sands companies have two main options: one is to increase the investment in the research of innovative technology that can reduce the ratio of water use in production, so as to satisfy the requirements of decreasing water allocation; and the other is to withdraw from the market, when the water restrictions are too hard for them to bear, and companies find it difficult to benefit from the projects, or they could earn more to invest on other projects. This second option is definitely the worse choice for them.

(3) NGOs

NGOs also play a very important role in the Alberta oil sands development. They have two options: one is to provide technical support. The organizations could obtain funds to support this research and to limit the impact of ecosystem problems to an acceptable level. Consequently, this option of cooperating with the government could benefit both of them; if the Alberta Government cannot allocate water effectively, or cannot prevent the oil sands industry from threatening fresh water ecosystems in the Athabasca River Basin,

NGOs may take the option to apply pressure on the Alberta Government or take legal action.

Based on the above explanation, the DMs and their options are provided in Table 4.1. In a conflict, a state is formed when each DM chooses an option. As all possible states are generated, infeasible states are eliminated according to the following rules.

Table 4.1: Decision Makers and Their Options

No.	Alberta Government(AG)	Options
1.	Funding	Set up specialized funding and cooperate with NGOs
2.	Legislation	Put forward more stringent restrictions on water use in Alberta River Water Management Framework (Phase II)
	Oil sands companies (OSC)	Options
3.	Investment	More investment in research, technology and equipment and cooperate with NGOs
4.	Withdrawal	Withdraw from oil sands market
	NGOs	Options
5.	Technical Support	Set up specialized funding and cooperate with NGOs
6.	Pressure	Apply pressure by using the media, or take legal action

- The oil sands companies will not take both actions—Invest and Withdraw—at the same time.
- If the local government does not set up funding and oil sands companies do not support NGOs, they would have no money to provide technical support.
- If the local government takes the action of legislation, then the OSCs would either increase the investment or withdraw.
- If the local government takes the action of legislation, NGOs will not apply pressure on the government.

After removing the infeasible states, 14 feasible states are left in this conflict. These feasible states indicate all possible scenarios that may occur in the conflict over water use

Table 4.2: Decision Makers, Options and Feasible States

AG	1. Funding	N	N	N	Y	N	Y	N
	2. Legislation	N	N	Y	N	N	N	Y
OSCs	3. Investment	N	Y	Y	N	Y	Y	Y
	4. Withdrawal	N	N	N	N	N	N	N
NGOs	5. Technical Support	N	N	N	Y	Y	Y	Y
	6. Pressure	N	N	N	N	N	N	N
Feasible States		s_1	s_2	s_3	s_4	s_5	s_6	s_7
AG	1. Funding	Y	N	N	Y	N	Y	-
	2. Legislation	Y	N	N	N	N	N	-
OSCs	3. Investment	Y	N	Y	N	Y	Y	-
	4. Withdrawal	N	N	N	N	N	N	Y
NGOs	5. Technical Support	Y	N	N	Y	Y	Y	-
	6. Pressure	N	Y	Y	Y	Y	Y	-
Feasible States		s_8	s_9	s_{10}	s_{11}	s_{12}	s_{13}	s_{14}

and oil sands development in the Athabasca River Basin. They are shown in Table 4.2. In this table, “Y” indicates that the option is chosen by a DM and “N” means not selected. A dash, given by “-”, means either a “Y” or “N”. A state is formed when each DM chooses a strategy. For example, state s_{14} is created when oil sands companies decide to withdraw from the market as indicated by the “Y” opposite option 4. The other available option selections will not affect the conflict as indicated by dashes opposite these options, where a dash means “Y” or “N”.

At the following stage of modelling using GMCR II, the option prioritizing is used to estimate the preferences of DMs. In the method, states are ranked according to lexicographic statements (Kilgour and Eden, 2010). The logical preference statements for each DM are described and explained in Tables 4.3, 4.4 and 4.5. Note that the options of DMs: Funding, Legislation, Investment, Withdraw, Technical Support, and Apply Pressure are represented by numbers 1, 2, 3, 4, 5, and 6. Preference statements are given from most important at the top to least important at the bottom.

Table 4.3: Preference Ordering Principals for the Alberta Government

Ordering statements	Explanation
-4	AG would give most priority to the state where: OSCs do not withdraw.
-6	AG would then give priority to the state where: NGOs do not take the action of applying pressure
1 IF 6	AG would then give priority to the state where: If NGOs take the action of applying pressure, AG prefers providing extra funding.
-2	AG would then give priority to the state where: AG will not take the action of legislation.
1 IF 3	AG would then give priority to the state where: AG would like to provide funding when OSCs make more investment.
-1	AG would then give priority to the state where: AG do not provide fund.
3	AG would then give priority to the state where: OSCs pay more on research and technology.
5	AG would then give priority to the state where: NGOs provide technical support.

Table 4.4: Preference Ordering Principals for Oil Sands Companies

Ordering statements	Explanation
-4	OSCs would give most priority to the state where: OSCs do not withdraw.
-2	OSCs would then give priority to the state where: AG do not take the action of legislation.
-6	OSCs would then give priority to the state where: If NGOs do not take the action of applying pressure.
-3	OSCs would then give priority to the state where: OSCs do not make investment.
1	OSCs would then give priority to the state where: AG provide extra funding
5	OSCs would then give priority to the state where: NGOs provide technical support.

Table 4.5: Preference Ordering Principals for NGOs

Ordering statements	Explanation
2	NGOs would give most priority to the state where: AG take the action of legislation.
6 IF -2	NGOs would then give priority to the state where: NGOs take the action of AAP if AG do not set up more stringent restrictions
-6	NGOs would then give priority to the state where: If NGOs do not take the action of applying pressure.
3	NGOs would then give priority to the state where: OSCs make more investment.
1	NGOs would then give priority to the state where: AG provide extra funding.
5	NGOs would then give priority to the state where: provide technical support

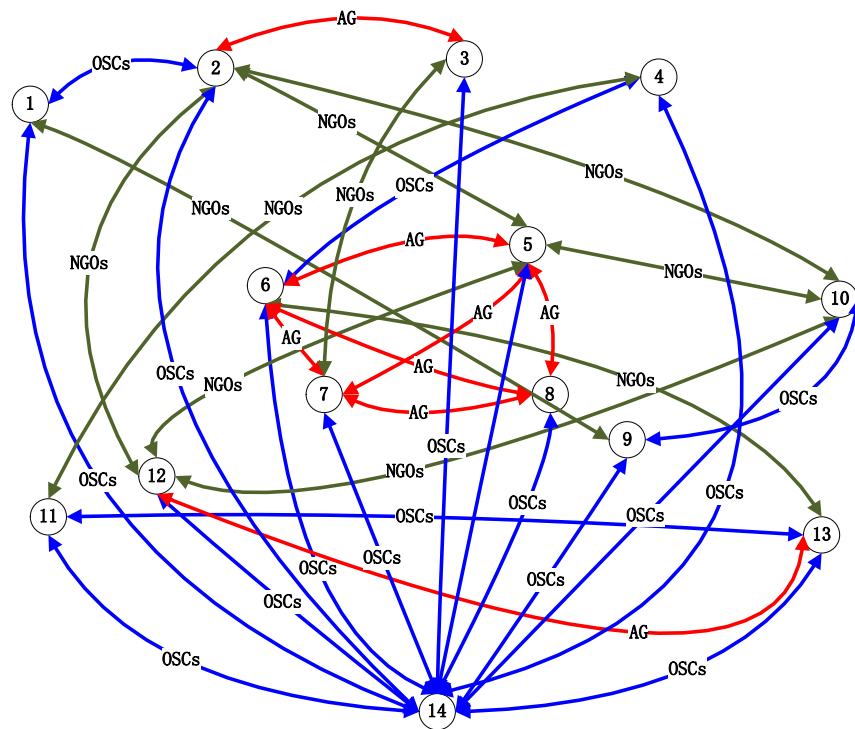

Figure 4.1: Integrated Transitional Graph of Water Use and Oil Sands Development Conflict in the Athabasca River Basin

The directed graph for the conflict of water use and oil sands development in the Athabasca River Basin is shown in Figure 4.1. In the directed graph, the vertices represent the 14 feasible states, and the arcs labelled by different DMs indicating unilateral moves of corresponding DMs.

4.5.3 Stability Analysis

Since the preferences of DMs have been determined by option prioritization, and DMs' unilateral moves are identified as shown in Figure 4.1. In this subsection, a stability analysis is carried out using GMCR II based on four stability definitions: Nash stability (R), general metarationality (GMR), symmetric metarationality (SMR), and sequential stability (SEQ), and the results are shown in Table 4.6. In the conflict, seven states are calculated as equilibria for all DMs, and these stable states are marked by a \checkmark under the corresponding stability definitions. The stable states represent the situations that may happen in the real world. Three representative Nash stable and sequentially stable states are discussed below:

In state s_{11} , the Alberta Government sets up specialized funding and cooperates with NGOs in researching the technology to increase efficiency of water use, such recycling water from tailing ponds. In this situation, NGOs would still apply pressure on the government and oil sands companies, because upgrading technologies may take a long time to develop and the public wishes to see a well developed industry without sacrificing the environment.

In state s_3 , the Alberta Government takes the action of legislation, and the oil sands companies invest in research, technology and equipment. In this situation, when more oil sands companies access the market, the conflict over water use and oil sands development may become more severe. Then the Alberta Government would create tighter legislation, to

Table 4.6: Stability Results for the conflict of water use and oil sands development

States		s_3	s_7	s_8	s_9	s_{11}	s_{12}	s_{14}
AG	Funding	N	N	Y	N	Y	N	-
	Legislation	Y	Y	Y	N	N	N	-
OSCs	Investment	Y	Y	Y	N	N	Y	N
	Withdrawal	N	N	N	N	N	N	Y
NGOs	Technical Support	N	Y	Y	N	Y	Y	-
	Pressure	N	N	N	Y	Y	Y	-
R					✓	✓		✓
GMR		✓	✓	✓	✓	✓	✓	✓
SMR		✓	✓	✓	✓	✓	✓	✓
SEQ		✓		✓	✓	✓		✓

assure that the industry is well monitored. When the quantity of fresh water use is strictly regulated, there will be fierce competition among oil sands companies in this market. The companies that effectively use limited quantity of fresh water will survive better in the future.

In state s_8 , the Alberta Government will set up specialized funding and cooperates with NGOs after putting forward more stringent restrictions on water use within the Alberta River Water Management Framework (Phase II), and NGOs would like to offer technical support. In addition, oil sands companies would also make extra investment in research, technology and equipment because of the pressure caused by the competition in the market. In this situation, The Alberta Government would like to see fierce competition among oil sands companies which should lead to highly developed technologies, but the government could not accept that most of the oil sands companies withdraw from the market when companies cannot afford the cost of research and development. Hence, both the Alberta Government and oil sands companies will offer funds to accelerate the development of the

oil sands industry and reduce environmental effects. This equilibrium indicates a trend: how the oil sands industry develops from a shorter to longer sighted perspective.

4.6 Conclusions

In this chapter, four main components (DMs, feasible states, possible movements controlled by each DM, and DM's preferences) are presented and explained in detail. When a conflict has two DMs, the concepts of unilateral moves and unilateral improvements for a DM are provided to identify reachable and preferred states from the initial state in one step by the DM. These concepts are then extended to deal with a conflict when multiple DM are involved in a conflict. After that, four basic stability definitions (Nash stability, general metarationality, symmetric metarationality, and sequential stability) are given along with their interpretations to carry out stability analysis in a strategic conflict with two or more DMs.

A conflict over water use and oil sands development in the Athabasca River Basin is proposed, and a stability analysis is carried out based on GMCR. In order to balance industrial development and environmental protection, the conflict among the Alberta government, oil sands companies, and non-governmental organizations is investigated. Seven states of the conflict are determined as equilibria according to the aforementioned four stability definitions, and interpretations for these equilibria are provided.

Chapter 5

Grey-based Preference in a Graph Model for Conflict Resolution with Two Decision Makers

The research contained in this chapter constitutes a significant expansion of classical Graph Model for Conflict Resolution (GMCR). The new methodology, using grey numbers to express uncertain preferences of DMs, formally puts forward grey preferences, and defines grey-based stability definitions within the GMCR structure, thereby extending the graph model methodology. Corresponding grey-based equilibria can then be identified, indicating more realistic resolutions for conflicts in the face of uncertainty.

In the literature, many studies have been conducted to address group decision making with uncertain preference information. For example, [Han et al. \(2013\)](#) concentrated on modelling grey conflict analysis based on grey input data, while [Ben-Haim and Hipel \(2002\)](#) used the information-gap model to estimate uncertainty of preference for DMs.

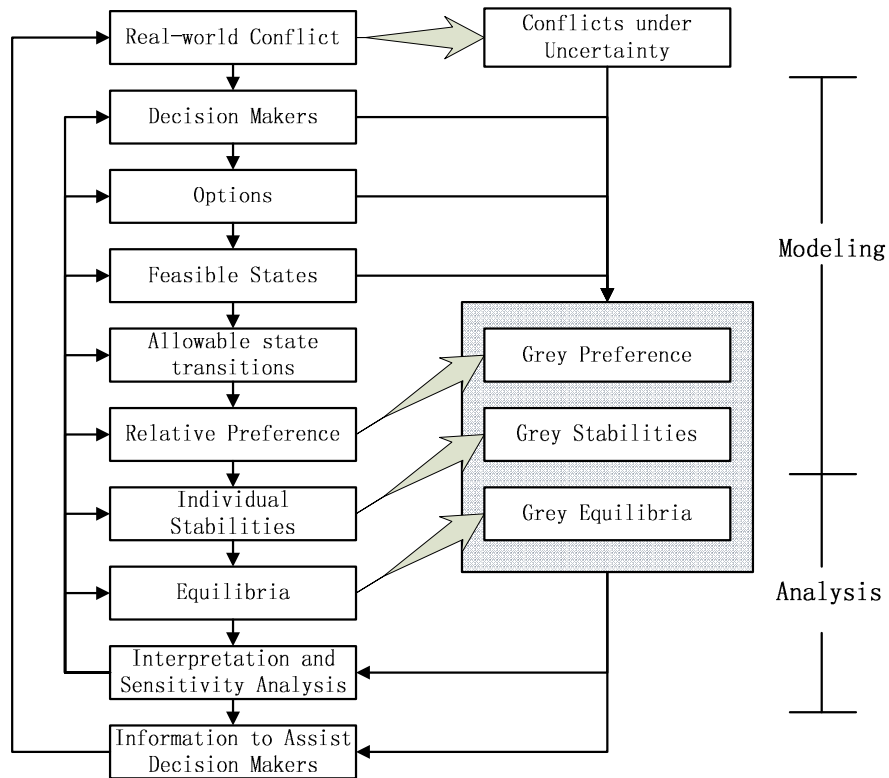

Figure 5.1: Main Contributions within the Framework of Conflict Analysis

Li et al. (2004) put forward a new preference relation—“prefer to”, “indifferent to”, and “unknown”—in modelling preference uncertainty in the graph model. Bashar et al. (2012) and Hipel et al. (2011) developed a fuzzy preference methodology to model and analyse conflicts under fuzzy preference uncertainty.

The main contributions of this approach within the framework of conflict analysis are shown in Figure 5.1, which is modified from Fang et al. (1993), and Fraser and Hipel (1984). Modelling a real-world conflict consists of identifying the DMs, their options, and their relative preferences over states. The current research extends the classical GMCR by mathematically defining grey preferences, grey stabilities, and grey equilibria. Moreover, interpretation and sensitivity analyses are carried out using a sustainable development conflict. The results can assist the DMs to make informed strategic choices.

5.1 Grey Preference Structure in the Graph Model

In the following subsections, the fundamental concepts of grey preference degree, grey relative certainty of preference, anticipated preference, grey satisficing threshold, and grey unilateral improvements are defined. These definitions are analogous, but different, to the corresponding definitions for fuzzy preferences in GMCR (Bashar et al., 2012), (Hipel et al., 2011). Based on these definitions, the concept of grey preference is incorporated into the graph model methodology, and four basic grey stability definitions in a conflict with two DMs are described.

5.1.1 Grey Preference Degree

When a DM needs to make a choice between two alternatives, sometimes he may easily make the decision, and strictly prefers one over another. For example, a vegetarian definitely prefers vegetables over meat; however, in some situations, it is hard for the DM to choose. For example, a vegetarian may be not sure whether he will cook tomato or potato for lunch. Then, uncertain preferences can capture a DM's intuition on how much an alternative is preferred to the other. A grey preference expresses uncertain preferences of DMs in a general way using generalized grey numbers, ranging from 0 to 1 (Kuang et al., 2013). Depending on the degree of uncertainty, a grey preference structure allows DMs to represent their preferences in different forms flexibly. For example, a DM can show his preference of one alternative over another as a value, 0.6, an interval, $[0.2, 0.4]$, or a combination of intervals, $\{[0.3, 0.4], [0.5, 0.6]\}$. The elements in these grey numbers represent the DM's possible preference degree for one state over another. Grey preferences constitute an extension of GMCR preference structures.

Definition 5.1 Grey Preference Degree: Let $D[0, 1]^\otimes$ represent the set of all grey numbers within the interval $[0, 1]$. A grey preference is an $m \times m$ matrix of grey numbers, $\otimes P = (\otimes p_{ij})_{m \times m}$, denoted as

$$\otimes p(s_i, s_j) = \otimes p_{ij} \in D[0, 1]^\otimes, \quad (5.1)$$

the GPD of state s_i over s_j satisfies $\otimes p_{ii} = 0.5$ for $i = 1, 2, \dots, m$, and if $\otimes p_{ij} \in \bigcup_{l=1}^L [p_{ij}^l, \bar{p}_{ij}^l]$, then $\otimes p_{ji} \in \bigcup_{l=1}^L [1 - \bar{p}_{ji}^l, 1 - p_{ji}^l]$ for $i, j = 1, 2, \dots, m$.

The grey-based preference degrees provided by Definition 5.1 can be interpreted as follows:

- (1) $\otimes p(s_i, s_j) = 0$ indicates state s_j is strictly preferred to s_i .
- (2) $\otimes p(s_i, s_j) \in D[0, 0.5]^\otimes$ and $\otimes p(s_i, s_j) \neq 0, 0.5$ indicates state s_i is less likely to be preferred to s_j .
- (3) $\otimes p(s_i, s_j) = 0.5$ means state s_i is equally likely to be preferred to s_j .
- (4) $\otimes p(s_i, s_j) \in D[0.5, 1]^\otimes$ and $\otimes p(s_i, s_j) \neq 0.5, 1$ indicates state s_i is more likely to be preferred to s_j .
- (5) $\otimes p(s_i, s_j) = 1$ indicates state s_i is strictly preferred to s_j .

Then, the grey preferences of DM k over all possible pairs of states in S can be represented by a grey preference matrix $(\otimes P^k)_{m \times m}$, generated through pairwise comparison among all possible pairwise combinations of states, and written as follows:

$$\otimes P^k = \begin{bmatrix} \otimes p_{11}^k & \otimes p_{12}^k & \dots & \otimes p_{1m}^k \\ \otimes p_{21}^k & \otimes p_{22}^k & \dots & \otimes p_{2m}^k \\ \dots & \dots & \dots & \dots \\ \otimes p_{m1}^k & \otimes p_{m2}^k & \dots & \otimes p_{mm}^k \end{bmatrix} \quad (5.2)$$

Note that an entry in $\otimes P^k$ indicates DM k 's preference degree for the row state over the column state.

Three examples are provided so as to further interpret grey preference structure. They are introduced as follows:

Example 5.1 *A brownfield property is for sale, and the government (G) has two options: offer financial and policy incentives (O) or not (N). From its own perspective, the government would prefer the option of N . However, successful redevelopment of the brownfield can increase tax revenue and employment opportunities, and remove the potential threat of*

pollution. The preference for N over O is $\otimes P^G_{NO} = 0.8$. This uncertain preference means the government does not definitely prefer N or O, but it is more likely to prefer N. Then, the preference matrix can be written as:

$$\otimes P^G = \begin{array}{c} \\ O \\ N \end{array} \begin{array}{cc} O & N \\ \left(\begin{array}{cc} 0.5 & 0.2 \\ 0.8 & 0.5 \end{array} \right) \end{array}$$

Example 5.2 *After a period of time, the property has not been sold, and citizens ask for environmental remediation. Considering the potential income after the property redevelopment and the possible social impacts, the government's preference over these two states has changed, and its preferences move from (N) towards O. However, it is hard to estimate the magnitude of its preferences change. Therefore, the uncertain preferences are represented using interval values. Compared with the preferences in Example 5.1, interval preferences mean that N is preferred over O for the government in general, but the degree of preference is not sure. The preference matrix for the government becomes:*

$$\otimes P^G = \begin{array}{c} \\ O \\ N \end{array} \begin{array}{cc} O & N \\ \left(\begin{array}{cc} 0.5 & [0.2, 0.4] \\ [0.6, 0.8] & 0.5 \end{array} \right) \end{array}$$

Example 5.3 *Later, it is clear that no buyer wants to purchase this property because of the potential risk of pollution, which may lead to endless liability regarding the cleanup of hazardous materials. An overall assessment of onsite contamination is undertaken. The government is eager to facilitate the transaction as soon as possible, and it is reluctant to wait for the assessment results. In this situation, considering the degree of pollution, its preferences of N over O are split into two parts. If the property is highly contaminated the*

preference of N over O is $[0.3, 0.5]$; but if the property is lightly contaminated the preference of N over O is $[0.6, 0.8]$. Then the preference matrix is:

$$\otimes P^G = \begin{array}{c} O \\ N \end{array} \begin{array}{cc} O & N \\ \left(\begin{array}{cc} 0.5 & \{[0.2, 0.4], [0.5, 0.7]\} \\ \{[0.3, 0.5], [0.6, 0.8]\} & 0.5 \end{array} \right) \end{array}$$

In modelling a conflict, different forms of grey number can be used to grasp the intuitions of DMs in comparing alternatives according to the degree of uncertainty, especially when information is limited and the options listed in the model do not cover all the concerns of DMs. Accordingly, it is meaningful for DMs to express their uncertain preferences using grey numbers.

5.1.2 Grey Relative Certainty of Preference

In a graph model, a grey preference reflects preference uncertainty using general grey numbers, indicating the grey preference degree to which a given state is preferred over another. As the grey preference degree of state s_i over s_j is $\otimes p(s_i, s_j)$, then $\otimes p(s_j, s_i)$ is a measure of the grey preference degree to which state s_i is not preferred to state s_j . Then, the grey relative certainty of preference represents the intensity of preference of one state over another.

Definition 5.2 Grey Relative Certainty of Preference (GRCP): Let $\otimes p^k(s_i, s_j)$ represent the grey preference degree of state s_i over s_j of DM $k \in N$, and $D[-1, 1]^\otimes$ represent the set of all grey numbers within the interval $[-1, 1]$. The GRCP for DM k of

state s_i relative to s_j is

$$\otimes r^k(s_i, s_j) = \otimes p^k(s_i, s_j) - \otimes p^k(s_j, s_i) \quad (5.3)$$

In (5.3), $\otimes r^k(s_i, s_j) \in D[-1, 1]^\otimes$. To assist in further interpretation, the following properties are provided. For DM k ,

(1) $\otimes r^k(s_i, s_j) = -1$ indicates state s_j is strictly preferred to s_i . A simplified notation for $\otimes r^k(s_i, s_j)$ is $\otimes r_{ij}^k$. Then, a grey relative certainty of preference for DM k over S is represented by a matrix $(\otimes r_{ij}^k)_{m \times m}$.

(2) $\otimes r^k(s_i, s_j) \in D[-1, 0]^\otimes$ and $\otimes r^k(s_i, s_j) \neq -1, 0$ indicates state s_i is less likely to be preferred to s_j .

(3) $\otimes r^k(s_i, s_j) = 0$ indicates state s_i is equally likely to be preferred to s_j .

(4) $\otimes r^k(s_i, s_j) \in D[0, 1]^\otimes$ and $\otimes r^k(s_i, s_j) \neq 0, 1$ indicates state s_i is more likely to be preferred to s_j .

(5) $\otimes r^k(s_i, s_j) = 1$ indicates state s_i is strictly preferred to s_j .

$$\otimes r^k = \begin{bmatrix} \otimes r_{11}^k & \otimes r_{12}^k & \dots & \otimes r_{1m}^k \\ \otimes r_{21}^k & \otimes r_{22}^k & \dots & \otimes r_{2m}^k \\ \dots & \dots & \dots & \dots \\ \otimes r_{m1}^k & \otimes r_{m2}^k & \dots & \otimes r_{mm}^k \end{bmatrix} \quad (5.4)$$

Example 5.4 Based on the preferences of Example 5.2, the grey relative certainty of preference of the government is:

$$\otimes P^G = \begin{matrix} & O & N \\ O & \left(\begin{array}{cc} 0.0 & [0.2, 0.6] \\ [-0.2, -0.6] & 0.0 \end{array} \right) \\ N & & \end{matrix}$$

After the transformation, one can easily tell the relative preference of one state over another: positive values mean more likely to be preferred, while negative values indicate less likely to be preferred. The presentation assists DMs in drawing a general picture of the whole conflict, especially when multiple DMs are involved.

5.1.3 Grey Unilateral Improvement

In GMCR, one of the main objectives is to determine whether a DM would prefer to move from one state to another. To identify states that are worthwhile to which to move for a DM, two key factors are defined in this section: anticipated preference (AP) and grey satisficing threshold (GST).

In this methodology, APs of DMs on feasible states are determined by characteristics of DMs. The characteristics of human beings, referring in this research to optimism, pessimism and neutral, have been studied for several decades (Caferra and Peltier, 2008; Chang et al., 2003; Chen, 2011; Scheier and Carver, 1985; Yager, 1995). These concepts can be interpreted in a decision process as reflecting how DMs respond differently to the same decision context. Optimistic DMs always hold a positive attitude and anticipate the most desirable outcomes taking place; while pessimistic DMs perceive situations negatively, and thereby thinking that less preferred outcomes may occur; and neutral DMs believe that an outcome having a middle level of preference will be the result (Chen, 2011).

Note that GRCP, introduced in Definition 5.2, is represented in the form of a general grey number. Then, AP is employed to estimate the preference of a DM expressed by GRCP, based on three types of characteristics of DMs: optimistic, pessimistic and neutral.

Definition 5.3 Anticipated Preference (AP): For $k \in N$, $s_i, s_j \in S$, let $\otimes r^k(s_i, s_j) \in \bigcup_{l=1}^n [\underline{x}_l, \bar{x}_l]$ denote the grey relative certainty of preference of s_i relative to s_j for DM k , and let \underline{r}_{ij}^k and \bar{r}_{ij}^k represent the lower bound and the upper bound of $\otimes r^k(s_i, s_j) \in \bigcup_{l=1}^n [\underline{x}_l, \bar{x}_l]$, respectively. Then, the DM k 's AP for s_i over s_j , denoted as $AP^k(s_i, s_j)$, is:

- If DM k is pessimistic, then

$$AP^k(s_i, s_j) = \underline{r}_{ij}^k \quad (5.5)$$

- If DM k is optimistic, then

$$AP^k(s_i, s_j) = \bar{r}_{ij}^k \quad (5.6)$$

- If DM k is neutral, then

$$AP^k(s_i, s_j) = \begin{cases} \frac{1}{n} \sum_{l=1}^n \underline{x}_l, & \text{if } \underline{x}_l = \bar{x}_l \text{ for all } l = 1, 2, \dots, n \\ \frac{\sum_{l=1}^n (\bar{x}_l - \underline{x}_l) \left(\frac{\bar{x}_l + \underline{x}_l}{2} \right)}{\sum_{l=1}^n (\bar{x}_l - \underline{x}_l)}, & \text{otherwise} \end{cases} \quad (5.7)$$

To assist in understanding these concepts, note that:

- Uncertain preferences over feasible states are represented with general grey numbers, which may consist of a set of intervals. A discrete value is the special case, in which the upper and lower bounds are the same.

- A pessimistic DM, holding a negative attitude, construes AP as the lower bound of GRCP.
- An optimistic DM, having a positive attitude, interprets AP as the upper bound of GRCP.
- The AP of a neutral DM is the centre of his GRCP. It can be further interpreted in two forms: the average of the values when they are all discrete; the calculation of AP depends on the mid-point and the length of each interval when intervals are present. Discrete values are not used in this calculation, since they are intervals having no width.

Definition 5.4 Grey Satisficing Threshold (GST): For $k \in N$ and $s, s_i \in S$, let $AP^k(s_i, s)$ denote AP of DM k for state s_i over s . Let γ_k be a real number such that $AP^k(s_i, s) \geq \gamma_k$ implies DM k would prefer to move from state s to s_i . Then γ_k is called the GST of DM k .

Note that $0 < \gamma_k \leq 1$. The GST of a DM is the degree of confidence that characterizes whether the DM finds a move worthwhile. Note that DMs may have different GSTs. In a grey-based preference structure, the decision to move or not is made by analysing the AP of the target state over the initial state. A DM will move from the initial state only to a state for which the AP is greater or equal to the DM's GST. For example, an aggressive DM may have a GST of 0.3, but a conservative DM may have a GST of 0.7. The latter DM would move to a state only when its AP over the initial state is not less than 0.7.

Since GRCP, AP, and GST have been formally defined, a DM's grey unilateral improvement is formally defined below:

Definition 5.5 Grey Unilateral Improvement (GUI) for a DM: For $k \in N$ and $s \in S$, let γ_k be the grey satisficing threshold for DM k . Recall that $R_k(s)$ denotes the set of states reachable from the state s for DM k . A state $s_i \in R_k(s)$ is called a GUI from s for DM k with respect to γ_k , if and only if $AP^k(s_i, s) \geq \gamma_k$.

A GUI is a preferred state that is reachable by a DM from the initial state. Specifically, a GUI is a reachable state for which AP over the initial state is greater than or equal to the GST of the DM.

Definition 5.6 Grey Unilateral Improvement (GUI) list for a DM: For $s \in S$ and $k \in N$, let $R_k(s)$ denote the set of states reachable from the state s by DM k , and γ_k be the grey satisficing threshold for DM k . The GUI list, denoted $\otimes R_{k, \gamma_k}^+(s)$, is the collection of all GUIs from s for DM k with respect to γ_k , represented mathematically as

$$\otimes R_{k, \gamma_k}^+(s) = \{s_i \in R_k(s) : AP^k(s_i, s) \geq \gamma_k\} \quad (5.8)$$

5.2 Grey Stabilities in a Conflict with Two Decision Makers

In GMCR, stability analysis aims to identify stable states for DMs participating in a strategic interaction. The initial state, stable or not, is called the status quo. The DM who has the right to move is called the focal DM. In a graph model with grey preferences, a GUI for a DM is a state to which the DM wishes to move. However, sanctions may be imposed by the other DM, and the focal DM may end up at less preferred states compared with the initial state. In this case, the initial state is stable.

In this section, the four basic grey-based stabilities in a strategic conflict are defined for a graph model with two DMs. Specifically, grey Nash stability (GR), grey general metarationality (GGMR), grey symmetric metarationality (GSMR), and grey sequential stability (GSEQ) are introduced. Note that these definitions depend on the grey preference structure that was described in Section 5.1.

Recall that $S = \{s_1, s_2, \dots, s_m\}$, $m > 1$ denotes the set of feasible states, and $N = \{p, q\}$ represents the set of two DMs. Then, GSTs for each DM, the APs for s_i over s_j , and GUIs from s of each DM are respectively denoted as γ_p and γ_q , $AP^p(s_i, s_j)$ and $AP^q(s_i, s_j)$, and $\otimes R_{p, \gamma_p}^+(s)$ and $\otimes R_{q, \gamma_q}^+(s)$. The formal definitions of the four grey stabilities are given below.

Definition 5.7 Grey Nash Stable (GR): A state $s \in S$ is GR for DM p , denoted by $s \in S_p^{GR}$, if and only if $\otimes R_{p, \gamma_p}^+(s) = \emptyset$.

In GR stability, the focal DM will definitely move to a more preferred state based on his AP and GST without considering possible subsequent countermoves by the other DM. In other words, for the focal DM, no state reachable from the initial state is more preferred, based on his satisficing criterion. Specifically, a state $s \in S$ is GR stable for DM p if and only if DM p has no GUI from s .

Theorem 5.7.1 Suppose that for every DM k , $\otimes r^k(s_i, s_j)$, the grey relative preference of DM k for s_i over s_j , equals either 1 or -1, for all states $s_i, s_j \in S$. Then a state $s \in S$ is grey Nash stable iff s is Nash stable in classical GMCR.

Proof: Let $N = \{p, q\}$ be the set of DMs, and let γ_p denote the GST of p . Let $\otimes R_{p, \gamma_p}^+(s) = \{s_i \in R_k(s) : AP^p(s_i, s) \geq \gamma_p\}$ represent the grey unilateral improvement list from state s for DM p . If $\otimes r^p(s_i, s_j) \in \{1, -1\}$, then $AP^p(s_i, s_j) = \underline{r}_{ij}^p = \bar{r}_{ij}^p =$

$\otimes r^p(s_i, s_j) \in \{1, -1\}$. Therefore, $\otimes r^p(s_i, s) \geq \gamma_p \equiv \otimes r^p(s_i, s) = 1$. Based on the grey preference relation, $\otimes r^p(s_i, s) = 1$ indicates $s_i \succ_p s$. Hence, if $\otimes r^p(s_i, s_j) \in \{1, -1\}$, $\otimes R_{p, \gamma_p}^+(s) = \{s_i \in R_p(s) : AP^p(s_i, s) \geq \gamma_p\} = \emptyset$ if and only if $\otimes R_p^+(s) = \{s_i \in R_p(s) : s_i \succ_p s\} = \emptyset$.

Remark: Theorem 5.7.1 extends to the following three grey stability definitions. Therefore, stability definitions of classical GMCR are special cases of grey-based GMCR.

Definition 5.8 Grey General Metarational (GGMR): A state $s \in S$ is GGMR for DM p , denoted by $s \in S_p^{GGMR}$, if and only if for every $s_1 \in \otimes R_{p, \gamma_p}^+(s)$ there exists at least one $s_2 \in R_q(s_1)$ such that $AP^p(s_2, s) < \gamma_p$.

In GGMR stability, the focal DM needs to consider not only his possible GUIs but also subsequent unilateral movements of the other DM. Specifically, a state s is GGMR for DM p if and only if moving to any GUI from s by DM p can be sanctioned by a subsequent unilateral movement of DM q . In other words, if p chooses to move from s to a GUI, s_1 , DM q has at least one unilateral movement from state s_1 to a state s_2 , which is less preferred by DM p compared with s , based on his satisficing criterion.

Definition 5.9 Grey Symmetric Metarational (GSMR): A state $s \in S$ is GSMR for DM p , denoted by $s \in S_p^{GSMR}$, if and only if for every $s_1 \in \otimes R_{p, \gamma_p}^+(s)$ there exists at least one $s_2 \in R_q(s_1)$ such that $AP^p(s_2, s) < \gamma_p$, and $AP^p(s_3, s) < \gamma_p$ for all $s_3 \in R_p(s_2)$.

In GSMR stability, the focal DM needs to consider not only his possible GUIs but also subsequent unilateral movements of the other DM, as well as the focal DM's possible counter-reactions. Specifically, a state s is GSMR for DM p if and only if moving to any GUI from s by DM p can be sanctioned by a subsequent unilateral movement by DM q ,

and DM p cannot escape this sanction by another unilateral movement. In other words, if DM p chooses to move to a GUI s_1 from s , DM q has a subsequent unilateral movement from state s_1 to s_2 , which is not advantageous for DM p to move from s , and so is any unilateral movement of DM p from s_2 , based on his satisficing criterion.

Theorem 5.9.1 *If state $s \in S$ is grey symmetric metarationally stable for DM p , then s is grey general metarational stable for DM p .*

Proof: For $N = \{p, q\}$, let $R_p(s)$ represent the reachable list from state s for DM p , and let $\otimes R_{p, \gamma_p}^+(s) = \{s_i \in R_p(s) : AP^p(s_i, s) \geq \gamma_p\}$ represent the grey unilateral improvement list from state s for DM p . If s is grey symmetric metarationally stable for DM p , then for any $s_1 \in \otimes R_{p, \gamma_p}^+(s)$ there exists at least one $s_2 \in R_q(s_1)$ such that $AP^p(s_2, s) < \gamma_p$. Hence, s is grey general metarational for DM p .

Remark: GSMR adds a restriction to GGMR. Therefore, if s is GSMR, it must also be GGMR. GGMR is used to define a noncooperative situation, where the opponent may take actions to sanction the focal DM's improvement without considering his own preferences. GSMR is applicable for DMs having strategic foresight. The focal DM needs to consider not only whether his improvement will be sanctioned by the opponent's countermoves, but also whether he can escape from this sanction.

Definition 5.10 Grey Sequentially Stable (GSEQ): *A state $s \in S$ is GSEQ for DM p , denoted by $s \in S_p^{GSEQ}$, if and only if for every $s_1 \in \otimes R_{p, \gamma_p}^+(s)$ there exists at least one $s_2 \in R_{q, \gamma_q}^+(s_1)$ such that $AP^p(s_2, s) < \gamma_p$.*

In GSEQ stability, the focal DM needs to consider not only his possible GUIs but also subsequent GUIs of the other DM. Specifically, a state s is GSEQ stable for DM p , if and

only if moving to any GUI from s by DM p can be sanctioned by a subsequent GUI of DM q . Stated differently, if DM p moves to a GUI s_1 from state s , DM q has at least one GUI from state s_1 to s_2 , which is less preferred for DM p compared with s , based on his satisficing criterion.

Theorem 5.10.1 *If state $s \in S$ is grey sequentially stable for DM k , then s is grey general metarational stable for DM k .*

Proof: For $N = \{p, q\}$, let $R_p(s)$ represent the reachable list from state s for DM p , and let $\otimes R_{p, \gamma_p}^+(s) = \{s_i \in R_p(s) : AP^p(s_i, s) \geq \gamma_p\}$ stand for the grey unilateral improvement list from state s for DM p . If s is grey sequentially stable for DM p , then for every $s_1 \in \otimes R_{p, \gamma_p}^+(s)$ there exists at least one $s_2 \in R_{q, \gamma_q}^+(s_1)$ such that $AP^p(s_2, s) < \gamma_p$. Note that $\otimes R_{p, \gamma_p}^+(s) \subseteq \otimes R_{p, \gamma_p}(s)$, that is, for every $s_1 \in \otimes R_{p, \gamma_p}^+(s)$ there exists at least one $s_2 \in R_q(s_1)$ such that $AP^p(s_2, s) < \gamma_p$. Hence, s is grey general metarational stable for DM p .

Remark: In general, because every unilateral improvement is also an unilateral movement, GSEQ implies GGMR. Hence, if s is GSEQ, it will also be GGMR. Compared with GGMR, GSEQ is suitable when the opponent only considers sanctioning the focal DM's improvement when he can benefit from the counter move.

Theorem 5.10.2 *If a state $s \in S$ is grey Nash stable for DM k , then s is also grey general metarationally stable, grey symmetric metarationally stable, and grey sequentially stable for DM k .*

Proof: For $N = \{p, q\}$, let $R_p(s)$ represent the reachable list from state s for DM p , and let $\otimes R_{p, \gamma_p}^+(s) = \{s_i \in R_p(s) : AP^p(s_i, s) \geq \gamma_p\}$ stand for the grey unilateral improvement

list from state s for DM p . If s is grey Nash stable for DM p , then $\otimes R_{p,\gamma_p}^+(s) = \emptyset$. Hence, Definitions 5.8, 5.9, and 5.10 are satisfied.

Remark: If a state s is GR for DM p , then the DM does not have any GUI from s to which to move. This also means that no GUI from s by DM p can be sanctioned by the opponent using any unilateral movement or GUI. Finding the relations among the stability definitions is helpful for interpreting a conflict in the process of stability analysis.

Definition 5.11 *A state $s \in S$ is called a grey equilibrium under a specific grey stability definition if and only if the state is grey stable for each DM under that grey stability definition.*

5.3 Case Study: Sustainable Development Conflict under Uncertainty

5.3.1 Background

The sustainable development conflict is a hypothetical generic conflict originally proposed by Hipel (2002). In this section, Grey-based GMCR, is applied to this conflict to formally handle preference uncertainty experienced by one of the two DMs. This application illustrates how the grey-based solution concepts can be used to analyse a conflict with two DMs having uncertain preferences. The fundamental components for the conflict are summarized as follows (Hipel, 2002):

- DMs: The model consists of two groups of DMs—Environmental agencies (ENV) and Developers (DEV).

- Options: ENV, aiming to meet human needs while protecting the environment from possible harm, can be proactive or reactive in monitoring the activities of DEV. DEV can choose sustainable development or unsustainable development. In summary, the options for ENV are to be (i) proactive or (ii) reactive, while the options for DEV are to practice (i) sustainable development or (ii) unsustainable development.
- Feasible States: Four feasible states are identified and listed in Table 5.1, in which “Y” means that the option is chosen and “N” means not selected. There are 4 states in this conflict, for which a state is formed when each DM chooses a strategy. For example, state s_1 is created when ENV is proactive in monitoring the activities of DEV, while DEV selects sustainable development.

Table 5.1: Feasible States for the Sustainable Development Conflict

ENV				
Proactive	Y	Y	N	N
DEV				
Sustainable	Y	N	Y	N
States Number	s_1	s_2	s_3	s_4

The directed graph in Figure 5.2 shows available transitions by ENV and DEV in a graph model. In this graph, the nodes represent the 4 feasible states for ENV and DEV, while the directed arcs, labelled by the DMs, represent their respective unilateral movements.

As mentioned above, in the original sustainable development conflict, uncertain preferences of DMs were not taken into account. However, the DMs involved in the conflict

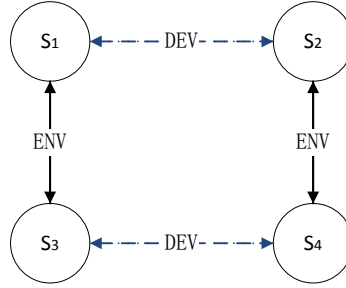

Figure 5.2: The Graph Model of Movement for the Sustainable Development Conflict

may be uncertain about preferences over the feasible states. [Li et al. \(2004\)](#) mentioned that preferences of DEV may be uncertain because they may be influenced by enforcement measures of ENV, and some members of DEV may feel more responsible for environmental protection.

5.3.2 Graph Model with Uncertainty

This research uses grey numbers to represent preferences of the DMs. Based on research for the sustainable development conflict conducted by [Hipel \(2002\)](#), [Li et al. \(2004\)](#), and [Bashar et al. \(2012\)](#), it is reasonable to assume that preferences of ENV over feasible states are all certain, and DEV has preference uncertainty between some states. Moreover, it is assumed that ENV is pessimistic and DEV is neutral ([Hipel, 2002; Li et al., 2004](#)). Then, through pairwise comparisons over the four feasible states, grey preference matrices are generated for ENV and DEV as listed in [Table 5.2](#).

Note that for P_{ENV} , the preference degrees are a single discrete values consisting of 1 or 0, representing certain preferences. In P_{DEV} , $\otimes p_{12} \in [0.1, 0.3]$ represents DEV's preference of sustainable development over unsustainable development when ENV is proactive. This

Table 5.2: Grey Preference Matrices of ENV and DEV

DMs	Grey preference matrices				
	s_1	s_2	s_3	s_4	
P_{ENV}	s_1	0.5	1.0	1.0	1.0
	s_2	0.0	0.5	0.0	1.0
	s_3	0.0	1.0	0.5	1.0
	s_4	0.0	0.0	0.0	0.5
P_{DEV}	s_1	0.5	[0.1, 0.3]	0.0	0.0
	s_2	[0.7, 0.9]	0.5	{[0.3, 0.4], [0.55, 0.75]}	0.0
	s_3	1.0	{[0.25, 0.45], [0.6, 0.7]}	0.5	0.0
	s_4	1.0	1.0	1.0	0.5

uncertainty is because some members of DEV may feel more responsible for environmental protection (Hipel and Walker, 2011). The expression $\otimes p_{23} \in \{[0.25, 0.45], [0.6, 0.7]\}$ indicates DEV's preference of sustainable development when ENV is reactive over unsustainable development when ENV is proactive. For DEV, this uncertainty is influenced by two main factors. One is that the level of enforcement measures is unknown, and hence preferences are split into two parts. In this situation, the preference of DEV does not change consistently. Specifically, if ENV adopts a higher level of enforcement measures, unsustainable development may be punished heavily. Thus, s_2 is less preferred than s_3 for DEV. On the contrary, if a lower level of enforcement measures is applied by ENV, possible countermeasures may be taken by DEV to achieve more profit through unsustainable development. Then, s_2 is more preferred than s_3 for DEV. The other factor is that some members of DEV may not agree with others. For example, some members may prefer sustainable development even when ENV employs a lower level of enforcement measures. This is the reason why each split part is expressed with an interval.

5.3.3 Stability Analysis

Based on grey preference matrices of ENV and DEV, GRCPs of the DMs can be calculated according to Equation (5.3), and the results are shown in Table 5.3. Then, according to the characteristics of the DMs, AP for ENV and DEV can be calculated respectively using Equations (5.5) and (5.7). For grey stability analysis, a GST needs to be entertained for each DM having uncertain preference. To analyse the sustainable development conflict under uncertainty, GSTs for DEV are classified into three ranges— $[0.0,0.06]$, $(0.06,0.6)$, and $[0.6,1.0]$ —based on the APs of DEV, which are $AP^{DEV}(s_2, s_1) = 0.6$ and $AP^{DEV}(s_2, s_3) = 0.06$.

Table 5.3: Grey relative certainty of Preferences of ENV and DEV

DMs	Grey Relative Certainty of Preferences Matrices				
	s_1	s_2	s_3	s_4	
P_{ENV}	s_1	0.0	1.0	1.0	1.0
	s_2	-1.0	0.0	-1.0	1.0
	s_3	-1.0	1.0	0.0	1.0
	s_4	-1.0	-1.0	-1.0	0.0
P_{DEV}	s_1	0.0	$[-0.8,-0.4]$	-1.0	-1.0
	s_2	$[0.4, 0.8]$	0.0	$\{[-0.4,-0.2],[-0.15,0.5]\}$	-1.0
	s_3	1.0	$\{[-0.5,0.15],[0.2,0.4]\}$	0.0	-1.0
	s_4	1.0	1.0	1.0	0.0

The stability results based on the four stability definitions—GR, GGMR, GSMR, GSEQ—are displayed in Table 5.4. In this table, a state that is stable for ENV or DEV is marked with a (\checkmark) , and a GE indicates that it is stable for both ENV and DEV under corresponding grey stability definitions.

Table 5.4: Stability Results for the Sustainable Development Conflict under Uncertainty - with Neutral DEV

GST	States	GR			GGMR			GSMR			GSEQ		
		ENV	DEV	GE	ENV	DEV	GE	ENV	DEV	GE	ENV	DEV	GE
[0.0,0.06]	s_1	✓			✓			✓			✓		
	s_2	✓	✓	✓	✓	✓	✓	✓	✓	✓	✓	✓	✓
	s_3				✓			✓			✓		
	s_4		✓			✓			✓			✓	
(0.06,0.6)	s_1	✓			✓			✓			✓		
	s_2	✓	✓	✓	✓	✓	✓	✓	✓	✓	✓	✓	✓
	s_3				✓	✓	✓	✓	✓	✓	✓	✓	✓
	s_4		✓			✓			✓			✓	
[0.6,1.0]	s_1	✓	✓	✓	✓	✓	✓	✓	✓	✓	✓	✓	✓
	s_2	✓	✓	✓	✓	✓	✓	✓	✓	✓	✓	✓	✓
	s_3				✓	✓	✓	✓	✓	✓	✓	✓	✓
	s_4		✓			✓			✓			✓	

5.3.4 Insights and Sensitivity Analysis

The findings in Table 5.4 provide some insights into the sustainable development conflict under uncertainty. When the GST ranges from 0 to 0.06, only one state, s_2 , is stable. In state s_2 , ENV is proactive, and DEV prefers unsustainable development. This result is exactly the same as the stability analysis conducted by [Hipel \(2002\)](#) when DEV definitely prefers unsustainable states to sustainable development, and uncertainty is not considered. When the GST takes a value from 0.06 to 0.6, a sustainable development state, s_3 , and an unsustainable state, s_2 , become stable. This result may be caused by the enforcement measures chosen by ENV, or by the environmentally friendly members of DEV. In this situation, it may not be worthwhile for DEV to move from a sustainable state to an

unsustainable state. When the GST is increased to the range of $[0.6,1.0]$, state s_1 becomes a new grey equilibrium, while s_2 and s_3 remain equilibria. Potentially, both ENV and DEV may search for a proper balance between the needs for social-economic development and environmental protection.

From the above results, a trend can be identified: as the GST increases, the equilibria change from unsustainable states to sustainable ones. To interpret this trend, notice that, the uncertain preference of DEV expressed by grey numbers reflects the higher environmental awareness of DEV members and their sensitivity to the potential enforcement measures levied by ENV. Based on the grey preference matrix for DEV, the majority of members of DEV are profit-driven, and put a higher priority on unsustainable development. Recall that for a GUI, APs must exceed GST. In this case study, the more GST increases, the more members of DEV practising sustainability need to be considered. In other words, when the GST is lower, sustainable development is more preferred. On the other hand, with the increase of the GST, sustainable development will gain more priority. Thus, if ENV can make more members realize the importance of environmental protection, or employ a higher level of enforcement measures against unsustainable development, a win-win relationship between ENV and DEV may be achieved.

In this case study, the characteristic of DEV is assumed to be neutral. To have a better understanding of grey-based GMCR, extra stability analyses are conducted when the characteristic of DEV is pessimistic or optimistic, and the results are shown in Tables 5.5 and 5.6, respectively. Based on the lower bound and the upper bound of each grey number, representing GRCPs of DEV, the GSTs of the DMs are classified into four ranges: $[0.0,0.4]$, $(0.4,0.5]$, $(0.5,0.8]$, and $(0.8,1.0]$. It is easy to conclude from the results the least stable states can be reached when DEV is optimistic, while the most stable states are available when DEV is pessimistic. These findings are caused by different definitions of

AP for DEV. It is clear that if a state is a GUI when DEV is pessimistic, it must also be a GUI when DEV is neutral or optimistic; and if a state is a GUI when DEV is neutral, it must also be a GUI when DEV is optimistic. As a consequence, if a state is stable when DEV is optimistic, it must also be stable when DEV is neutral or pessimistic; and if a state is stable when DEV is neutral, it must also be stable when DEV is pessimistic.

Table 5.5: Stability Findings for the Sustainable Development Conflict under Uncertainty - with Pessimistic DEV

GST	States	GR			GGMR			GSMR			GSEQ		
		ENV	DEV	GE	ENV	DEV	GE	ENV	DEV	GE	ENV	DEV	GE
[0.0,0.4]	s_1	✓			✓			✓			✓		
	s_2	✓	✓	✓	✓	✓	✓	✓	✓	✓	✓	✓	✓
	s_3				✓	✓		✓	✓		✓	✓	
	s_4		✓			✓			✓			✓	
(0.4,0.5]	s_1	✓	✓	✓	✓	✓	✓	✓	✓	✓	✓	✓	✓
	s_2	✓	✓	✓	✓	✓	✓	✓	✓	✓	✓	✓	✓
	s_3				✓	✓	✓	✓	✓	✓	✓	✓	✓
	s_4		✓			✓			✓			✓	
(0.5,0.8]	s_1	✓			✓			✓			✓		
	s_2	✓	✓	✓	✓	✓	✓	✓	✓	✓	✓	✓	✓
	s_3				✓	✓	✓	✓	✓	✓	✓	✓	✓
	s_4		✓			✓			✓			✓	
(0.8,1.0]	s_1	✓	✓	✓	✓	✓	✓	✓	✓	✓	✓	✓	✓
	s_2	✓	✓	✓	✓	✓	✓	✓	✓	✓	✓	✓	✓
	s_3				✓	✓	✓	✓	✓	✓	✓	✓	✓
	s_4		✓			✓			✓			✓	

5.4 Conclusions

The proposed methodology of grey-based GMCR forms a solid framework for conflict resolution under uncertainty. Grey numbers allow DMs to express their uncertain preferences based on their particular concerns, and can provide more information for DMs to make more enlightened decisions.

Table 5.6: Stability Results for the Sustainable Development Conflict under Uncertainty - with Optimistic DEV

GST	States	GR			GGMR			GSMR			GSEQ		
		ENV	DEV	GE	ENV	DEV	GE	ENV	DEV	GE	ENV	DEV	GE
[0.0,0.4]	s_1	✓			✓			✓			✓		
	s_2	✓	✓	✓	✓	✓	✓	✓	✓	✓	✓	✓	✓
	s_3				✓			✓			✓		
	s_4		✓			✓			✓			✓	
(0.4,0.5]	s_1	✓			✓			✓			✓		
	s_2	✓	✓	✓	✓	✓	✓	✓	✓	✓	✓	✓	✓
	s_3				✓			✓			✓		
	s_4		✓			✓			✓			✓	
(0.5,0.8]	s_1	✓			✓			✓			✓		
	s_2	✓	✓	✓	✓	✓	✓	✓	✓	✓	✓	✓	✓
	s_3				✓	✓	✓	✓	✓	✓	✓	✓	✓
	s_4		✓			✓			✓			✓	
(0.8,1.0]	s_1	✓	✓	✓	✓	✓	✓	✓	✓	✓	✓	✓	✓
	s_2	✓	✓	✓	✓	✓	✓	✓	✓	✓	✓	✓	✓
	s_3				✓	✓	✓	✓	✓	✓	✓	✓	✓
	s_4		✓			✓			✓			✓	

In this work, a grey preference structure was introduced, and related definitions (GUI, GST, and AP) were presented to facilitate DMs to make judgements when they have uncertain preferences. Then, four solution concepts (GR, GGMR, GSMR, and GSEQ) were defined and related theorems put forward. It was also demonstrated that stability definitions of classical GMCR are special cases of grey-based GMCR.

A case study of sustainable development with two DMs was carried out. Through the comparison with classical GMCR, the grey-based stability analysis results suggested a trend in how the equilibria change. This trend can be helpful for finding the reality hidden behind the uncertainty, and can also assist DMs to estimate the potential evolution of the conflict. In real-world applications, if one can discover where the source of the uncertainty lies, and determine stability analysis results generated by the grey based graph model, the influence of uncertainty on the conflict may be better understood. Therefore, DMs can put appropriate countermeasures in place to influence the evolution of the conflict.

Chapter 6

Grey-based Preference in a Graph Model for Conflict Resolution with Multiple Decision Makers

6.1 Grey-based Graph Model for Conflict Resolution with Multiple Decision Makers

In this chapter, a definition for grey preference, based on grey numbers, is incorporated into the Graph Model for Conflict Resolution (GMCR) in a multiple decision maker context, in order to model uncertain human behaviour in a strategic conflict. When more than two decision makers (DMs) are involved in a conflict, coordinated moves against a focal decision maker must be taken into account when identifying stable states. Hence, a new set of stability definitions is developed for an n -DM ($n \geq 2$) grey-based graph model. A case study of negotiation under uncertainty in a brownfield redevelopment conflict is presented

to demonstrate the proposed methodology.

6.1.1 Grey Unilateral Improvements for a Conflict with Multiple Decision Makers

When more than two DMs are involved in a conflict, coordinated unilateral improvements for two or more DMs must be taken into account. The unilateral improvement list for n ($n > 1$) DMs from a given state represents a collection of all possible states to which some or all of the DMs can move via a legal sequence of movements, and each movement is an grey unilateral improvement. Recall that a legal sequence of grey moves means that the same DM may move more than once, but not twice consecutively.

A number of grey-based concepts within the framework of GMCR have been formally defined in Chapter 5, such as grey preference degree (Definition 5.1), grey relative certainty of preferences (GRCP) (Definition 5.2), anticipated preferences (AP) (Definition 5.3), grey satisficing threshold (GST) (Definition 5.4), and grey unilateral improvement (GUI) list for a DM (Definition 5.6). Based on these definitions, a DM's grey unilateral improvements (GUIs) in a conflict having multiple DMs is introduced as follows:

Definition 6.1 Grey Unilateral Improvement List for Multiple DMs: For $s \in S$, $H \subseteq N$ and $H \geq 2$, let $H = \{1, 2, \dots, h\}$, and $\gamma_H = \{\gamma_1, \gamma_2, \dots, \gamma_h\}$ represent a set of GSTs for corresponding DMs. Let $\otimes R_{k, \gamma_k}^+(s)$ be the collection of all GUIs from state s for DM k with respect to γ_k , and $\Omega_H^+(s, s_i)$ denote the set of all last DMs in legal sequences allowable for unilateral improvement from s to s_i . Then, the grey unilateral improvement list $\otimes R_{H, \gamma_H}^+(s)$ from state s for H is defined inductively as

- (1) if $k \in H$, and $s_1 \in \otimes R_{k, \gamma_k}^+(s)$, then $s_1 \in \otimes R_{H, \gamma_H}^+(s)$ and $k \in \Omega_H^+(s, s_1)$

(2) if $s_1 \in \otimes R_{H,\gamma_H}^+(s)$, $k \in H$, $s_2 \in \otimes R_{k,\gamma_k}^+(s_1)$, and $\Omega_H^+(s, s_1) \neq \{k\}$, then $s_2 \in \otimes R_{H,\gamma_H}^+(s)$ and $k \in \Omega_H^+(s, s_2)$

Note that the definition stops only when no new state can be added. A coordinated grey unilateral improvement from a given state by multiple DMs is a state that is in the reachable list for these DMs from the initial state and worthwhile for some or all of the DMs to move to. Specifically, if a group of DMs, H , moves the conflict from state s_1 to s_2 via a legal sequence of moves and each movement is a grey unilateral improvement for corresponding DM judged by Definition 5.5, then s_2 is a grey unilateral improvement for H , as well as other movements. The unilateral improvement list for multiple DMs is the collection of all grey unilateral improvements from the given state for any non-empty subset of the DMs. To help understand this definition of GUI for multiple DMs, an illustrative example of a graph model for the movements controlled by the DMs is provided.

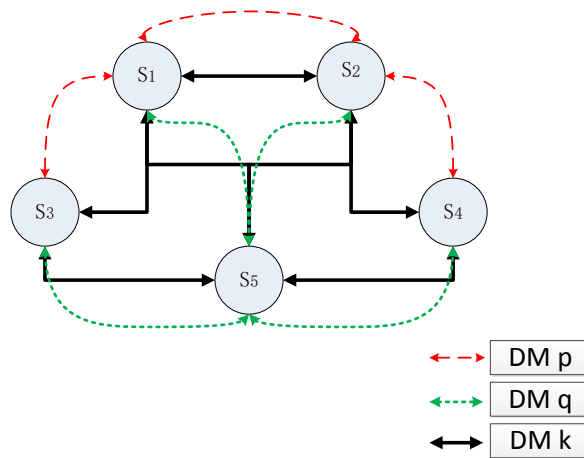

Figure 6.1: A Graph Model for a Simple Conflict

Example 6.1 In Figure 6.1, the conflict includes three DMs, $N = \{p, q, k\}$, and five states, $S = \{s_1, s_2, s_3, s_4, s_5\}$. The arcs are color-coded to indicate the controlling DMs.

In the conflict, DM k can unilaterally move the conflict from state s_1 to s_2 and back as indicated by the arrow heads, and DM p can unilaterally move from state s_2 to s_4 and back. The five feasible states and the three DMs' possible moves constitute the graph model for the conflict.

To carry out stability analysis, one needs to identify states that are reachable within one step or within a legal sequence of coordinated moves by a group of DMs from the initial state. In Figure 6.1, DM p can unilaterally move the conflict from state s_1 to s_2 , or to s_3 . Hence, s_2 and s_3 are reachable for DM p from state s_1 in the conflict, and the reachable list from state s_1 for DM p is $R_p(s_1) = \{s_2, s_3\}$.

The unilateral improvements of a DM from the initial state are determined based on the DM's AP and his GST. The movement of a DM from the initial state to a preferred state constitutes a unilateral improvement. A collection of all the unilateral improvements from the initial states is a unilateral improvement list. Assume that the AP of state s_1 over s_2 by DM k is equal or larger than his GST, the movement of DM k from state s_2 to s_1 is a grey unilateral improvement. If s_1 is the only grey unilateral improvement from s_2 for DM k , then the grey unilateral improvement list from state s_2 for DM k is $\otimes R_{k,\gamma_k}^+(s_2) = \{s_1\}$.

In order to identify all reachable states from the initial state, coordinated moves of DMs need to be considered. In this conflict, DM k cannot unilaterally move the conflict from state s_1 to s_4 in one step. However, he can move from s_1 to s_2 , and then, DM p can move from s_2 to s_4 . Hence, s_4 is reachable from s_1 . Since s_4 is the only reachable state from s_1 by coordinated moves of DMs k and p , if $H = \{k, p\}$, $R_H(s_1) = \{s_4\}$. It is easy to see that s_2 , s_3 , s_4 , and s_5 are all reachable states from s_1 by one or more DMs' coordinated moves.

Definition 6.1 aims at defining states that are reachable from the initial state by coordinated moves of DMs, and are worthwhile for each DM to move from the initial state. In

Figure 6.1, if s_2 is a grey unilateral improvement for DM k from s_1 , and s_4 is also a grey unilateral improvement for DM p from s_2 , then s_4 is a grey unilateral improvement from s_1 for DM k and p . Moreover, s_4 is the only reachable state from s_1 by coordinated moves of DMs k and p . Hence, if $H = \{k, p\}$, then $\otimes R_{H, \gamma_H}^+(s_1) = \{s_4\}$.

6.1.2 Grey Stabilities Definitions and Equilibria

The stability definitions proposed in Chapter 5 are for a graph model with exact two DMs, where the opponent of a focal DM is a single DM. When a conflict have more than two DMs, the opponent of a focal DM is a group (or coalition) of DMs. Hence, Since Nash stability does not depend on the responses of the opponent(s), the definition of grey Nash stability for an n -decision Maker ($n \geq 2$) graph model is the same as the two-DM case. The stability concepts of grey general metarationality (GGMR), grey symmetric metarationality (GSMR) and grey sequential stability (GSEQ) in a n -DM ($n \geq 2$) conflict are developed to deal with strategic conflict with multiple DMs in this chapter. These definitions depend on GSTs, characteristics of DMs and their corresponding APs (referring to Chpater 5), and unilateral moves controlled by DMs, GUIs. Note that $S = \{s_1, s_2, \dots, s_m\}$, $m > 1$ denotes the set of feasible states and N represents the set of DMs. The formal definitions of the three grey stabilities for a conflict having multiple DMs are given below.

Definition 6.2 Grey General Metarational (GGMR): A state $s \in S$ is grey general metarational for DM k , denoted by $s \in S_k^{GGMR}$, if and only if for every $s_1 \in \otimes R_{k, \gamma_k}^+(s)$ there exists at least one $s_2 \in R_{N-\{k\}}(s_1)$ such that $AP^k(s_2, s) < \gamma_k$.

If DM k chooses to move from s to a GUI, s_1 , and the other DMs, $N - \{k\}$, have at least one unilateral movement from state s_1 to a state s_2 , which is less preferred for DM k than

s , based on his preference, characteristics, and satisficing criterion, then the GUI from s to s_1 for DM k is blocked. If every GUI from s by DM k can be blocked by some or all the other DMs' unilateral movements, then the state s is GGMR for DM k .

Definition 6.3 Grey Sequentially Stable (GSEQ): A state $s \in S$ is grey sequentially stable for DM k , denoted by $s \in S_k^{GSEQ}$, if and only if for every $s_1 \in \otimes R_{k,\gamma_k}^+(s)$ there exists at least one $s_2 \in \otimes R_{N-\{k\},\gamma_{N-\{k\}}}^+(s_1)$ such that $AP^k(s_2, s) < \gamma_k$.

If DM k chooses a GUI s_1 from state s to move to, and the other DMs, $N - \{k\}$, have at least one GUI from state s_1 to s_2 , which is not worthwhile for DM k to move from s based on his preference, characteristics, and satisficing criterion. If every GUI from s by DM k can be blocked by some or all the other DMs using GUIs given in Definition 6.1, then the state s is GSEQ for DM k .

Definition 6.4 Grey Symmetric Metarational (GSMR): A state $s \in S$ is grey symmetric metarational for DM k , denoted by $s \in S_k^{GSMR}$, if and only if for every $s_1 \in \otimes R_{k,\gamma_k}^+(s)$ there exists at least one $s_2 \in R_{N-\{k\}}(s_1)$ such that $AP^k(s_2, s) < \gamma_k$, and $AP^k(s_3, s) < \gamma_k$ for all $s_3 \in R_{N-\{k\}}(s_2)$.

If DM k chooses to move to a GUI s_1 from s , and the other DMs, $N - \{k\}$, have subsequent unilateral movements from state s_1 to s_2 , which is not worthwhile for DM k from s to move to, and neither is any unilateral movement of DM k from s_2 , based on his preference, characteristics, and satisficing criterion, then the GUI from s to s_1 is blocked for DM k . If every GUI from s by DM k can be blocked in the manner described above, then the state s is GSMR for DM k .

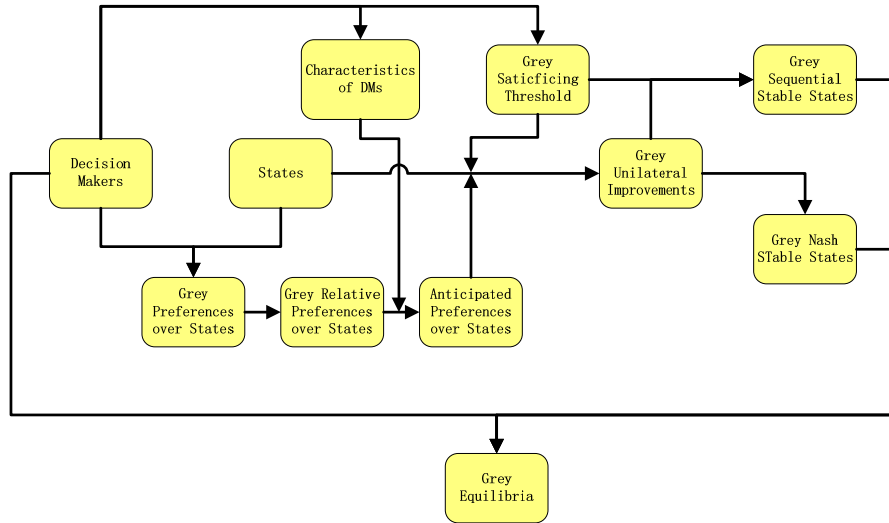

Figure 6.2: Flow Chart for grey-based Graph Model for Conflict Resolution

Definition 6.5 Grey Equilibrium: A state $s \in S$ is called a grey equilibrium under a specific grey stability definition if and only if the state is grey stable for all DMs under that grey stability definition.

Figure 6.2 is a flowchart that shows the procedure of the grey-based GMCR methodology, and explains the relations of definitions provided above. AP for each DM over all states are determined based on the DM's characteristic and preferences. The GUI from the initial states for a DM are identified based on the DM's AP and GST. The grey stable states change when the DMs' GSTs change. Based on the two basic grey stability definitions, grey stable states reflect mainly the possibility of GUIs, which are directly related to the GST for each DM.

6.2 Negotiation of Brownfield Redevelopment Conflict under Uncertainty

6.2.1 Background of Kaufman Site Redevelopment Conflict

This case study of brownfield redevelopment conflict was proposed by [Bernath Walker et al. \(2010\)](#). To take uncertain preferences of DMs into consideration, [Bashar et al. \(2012\)](#) used fuzzy preferences to analyze conflict behaviour and identify possible resolutions to this dispute. In this section, the grey-based preferences are employed to represent multiple DMs' uncertain preferences with grey numbers, and the grey-based solution concepts designed for a conflict with multiple DMs are used to analyze the conflict under uncertainty. The definitions of anticipated preferences, grey satisficing threshold, grey unilateral improvements, and grey-based stability definitions are originally defined by [Kuang et al. \(2014a,b\)](#).

The Kaufman Footwear factory was a shoe manufacturing company located in Kitchener, Ontario, Canada. The company contributed to the local economy for several decades, and constituted an important part of the city's industrial history. As both a brownfield site and a designated heritage building, the Kaufman footwear factory site has been successfully redeveloped into residential lofts featuring a high roofline and large windows. This section examines the successful renovation of the Kaufman Footwear company, simulates interactions of the involved DMs with uncertain preferences, demonstrates the feasibility and effectiveness of the proposed methodology, and provides valuable insight into the strategic nature of the brownfield redevelopment conflict.

[Bernath Walker et al. \(2010\)](#) divided the brownfield redevelopment conflict into three phases: Acquisition, Remediation Selection, and Renovation/Redevelopment. This research focuses on the acquisition conflict. The fundamental components for the conflict

are summarized as follows:

- DMs: The graph model for the conflict consists of three DMs: (i) Property Owner (PO) who aims at selling this property at as high as possible price; (ii) Developer (D) who tries to make profitable businesses; and (iii) City Government (CG), whose purpose is to increase tax revenue and employment opportunities, and to provide healthy neighbourhoods, while efficiently and effectively allocating government resources.
- Options: PO has three options: sell the property at a high price, sell low, or walk away. According to PO's quotation, D may accept this price or refuse to buy the property. CG may offer financial and policy oriented incentives or not.
- Feasible States: Feasible states are identified and listed in Table 6.1, in which "Y" means that the option is chosen by a DM, and "N" means it is rejected. A dash, given by "-", means either a "Y" or "N". In a conflict, a state is formed when each DM chooses a strategy. For example, the state s_2 is formed when PO sells his property at a high price, while CG refuses to offer related incentives, and D does not accept this, and waits to see if changes occur. Because each option for the corresponding DM may be selected or not, in principle, there may be $2^6 = 64$ states in this dispute. However, some of these states are infeasible. For example, PO cannot choose both to sell the property at a high price and to walk away at the same time. After removing infeasible states, thirteen feasible states remain as listed in Table 6.1.

The feasible states describe all possible outcomes of the brownfield redevelopment conflict. State s_1 is interpreted as the status quo, in which none of the three DMs takes any action. In states s_2 to s_6 , D doesn't accept the options provided by PO and CG, and waits to see if it is possible to gain much more from the conflict. These states can be

Table 6.1: DMs, Options, and States in the Acquisition Conflict of Brownfield Redevelopment (Modified from (Bernath Walker et al., 2010))

Property Owner (PO)	Sell High	N	Y	N	N	Y	N	N	Y	N	Y	N	-	-
	Sell Low	N	N	Y	N	N	Y	N	N	Y	N	Y	-	-
	Walk	N	N	N	N	N	N	N	N	N	N	N	-	Y
City Government (CG)	Incentives	N	N	N	Y	Y	Y	N	N	N	Y	Y	-	-
Developer (D)	Buy	N	N	N	N	N	N	Y	Y	Y	Y	Y	-	-
	Walk	N	N	N	N	N	N	N	N	N	N	N	Y	-
Feasible States		s_1	s_2	s_3	s_4	s_5	s_6	s_7	s_8	s_9	s_{10}	s_{11}	s_{12}	s_{12}

considered as transitional states of this negotiation. States s_8, s_9, s_{10} , and s_{11} represent possible agreements. Another important feature of the conflict is that either D or PO can choose the option “Walk”, thereby ending the conflict at s_{12} . Hence, the last two states are the same and marked s_{12} . For example, state s_{12} is created when PO chooses the option “Walk” as indicated by the “Y” opposite options 3. The option selections of D and CG will not affect the conflict as indicated by dashes opposite their options. Meanwhile, s_{12} can also be created when D chooses “Walk”, and the option selections of PO and CG will not affect the conflict either.

The directed graph in Figure 6.3 shows available transitions by PO, CG, and D, where the nodes represent the twelve feasible states, and the color-coded arcs indicate the DMs’ unilateral moves that are controlled by corresponding DMs. For example, CG can unilaterally move the conflict from state s_1 to s_4 and back as indicated by the arrow heads, while PO can unilaterally move the conflict from state s_1 to state s_3 and back.

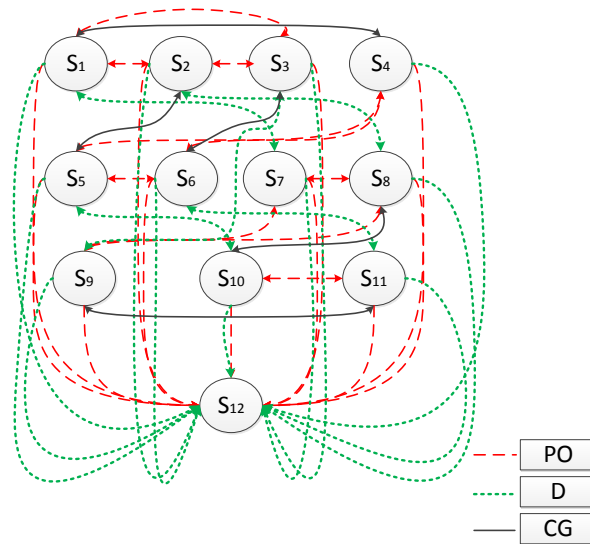

Figure 6.3: Integrated Directed Graph of the Property Acquisition Conflict (Modified from (Bernath Walker et al., 2010))

6.2.2 Grey-based Uncertain Preferences for the Decision Makers

After the identification of all feasible states in the conflict, the next target is to develop grey preferences for the three DMs over the twelve feasible states. In general, for PO, states that sell the property at a high price are preferred over states with a low selling price; for CG, states without incentives are highly preferred. However, in order to facilitate the transaction, reasonable incentives can be provided if necessary; and D desires to both purchase the property at a low price from PO and receive the incentives from CG.

Compared with greenfield development, brownfield redevelopment requires extra investment for cleaning up hazardous waste. In this conflict, the soil beneath the Kaufman Factory is contaminated by liquid naphthalene, which was used in the production of safety boots (Bernath Walker et al., 2010). Considering the uncertainties caused by the unpredictable nature of remediation, DMs may have different concerns in the redevelopment.

Before D's decision to make an investment, he must assure that the revenue of the project exceeds the input. It is hard to predict the cost and time required for cleaning up the hazardous waste, so D may be reluctant to purchase this property even at a lower price if he is faced with high liability risk. On the contrary, if the pollution is estimated to be under control, he may consider the investment, and a higher price may also be acceptable because of future economic profit. Because of the uncertain degree of contamination, which may threaten human health and cause social issues, CG may move towards offering incentives. The redevelopment may expose PO to endless liability if the site is highly polluted, so he would like CG to share the risk by providing incentives. Taking into account the situations mentioned above, the grey preferences of PO, D and CG are inferred and presented by matrices PO, D and CG.

Table 6.2: Grey Preference Matrices of PO

DM	Grey preference matrices											
	s_1	s_2	s_3	s_4	s_5	s_6	s_7	s_8	s_9	s_{10}	s_{11}	s_{12}
s_1	0.5	0.5	1	0.4	0.3	1.0	0.2	0	1	0	0.9	0.8
s_2	0.5	0.5	1	0.4	0.3	1.0	0.2	0	1	0	0.9	0.8
s_3	0	0	0.5	0.2	0	1.0	0.2	0	1	0	0.8	0.7
s_4	0.6	0.6	0.8	0.5	0.3	0.6	0.3	0	1	0	1	0.8
s_5	0.7	0.7	1	0.7	0.5	1	0.2	0	1	0	1	0.8
s_6	0	0	0	0.4	0	0.5	0	0	1	0	1	0.6
s_7	0.8	0.8	0.8	0.7	0.6	1	0.5	0	1	0	1	1
s_8	1	1	1	1	1	1	1	0.5	1	[0.2,0.4]	1	1
s_9	0	0	0	0	0	0	0	0	0.5	0	0.4	[0.2,0.3]
s_{10}	1	1	1	1	1	1	1	[0.6,0.8]	1	0.5	1	1
s_{11}	0.1	0.1	0.2	0	0	0	0	0	0.6	0	0.5	[0.3,0.4]
s_{12}	0.2	0.2	0.3	0.2	0.2	0.4	0	0	[0.7,0.8]	0	[0.6,0.7]	0.5

Table 6.2 can be interpreted in this way: the value 0.5 means the pair of states are equally preferred. For PO, s_1 and s_2 are equally preferred. Preferences ranging from 0.5 to 1 mean that the states in the rows are more likely to be preferred than those in the columns. For example, the preference for state s_{10} over state s_8 is [0.6, 0.8]. The incentives

offered by CG cannot change the profit accrued by PO from selling the property at a high price, but it can help to convince D to accept the price, thereby facilitating the transaction. On the contrary, preferences ranging from 0 to 0.5 mean the states in the rows are likely less preferred than those in the columns. The value of 1 means preferred, and 0 means not preferred. For example, state s_8 is strictly preferred to s_9 , because PO always prefers to sell the property at a high price.

Table 6.3: Grey Preference Matrices of CG

DM	Grey preference matrices												
	s_1	s_2	s_3	s_4	s_5	s_6	s_7	s_8	s_9	s_{10}	s_{11}	s_{12}	
<i>PCG</i>	s_1	0.5	0.6	0.4	0.3	0.4	0.2	0.3	0	0	0	0	1
	s_2	0.4	0.5	0.3	0.2	0.4	0.2	0.4	0	0	0	0	1
	s_3	0.6	0.7	0.5	0.4	0.6	0.4	0.4	0	1	0	0	1
	s_4	0.7	0.8	0.6	0.5	0.6	0.3	0.4	0	1	0	0	1
	s_5	0.6	0.6	0.4	0.4	0.5	0.2	0.3	0	1	0	0	1
	s_6	0.8	0.8	0.6	0.7	0.8	0.5	0.5	0	1	0	0	1
	s_7	0.7	0.6	0.6	0.6	0.7	0.5	0.5	0	1	0	0	1
	s_8	1	1	1	1	1	1	1	0.5	[0.3,0.5]	[0.4,0.5][0.6,0.8]	[0.3,0.5][0.7,0.9]	1
	s_9	1	1	1	1	1	1	1	[0.5,0.7]	0.5	[0.1,0.4][0.6,0.7]	[0.4,0.5][0.6,0.8]	1
	s_{10}	1	1	1	1	1	1	1	[0.2,0.4][0.5,0.6]	[0.3,0.4][0.6,0.9]	0.5	[0.3,0.5]	1
	s_{11}	1	1	1	1	1	1	1	[0.1,0.3][0.5,0.7]	[0.2,0.4][0.5,0.6]	[0.5,0.7]	0.5	1
	s_{12}	0	0	0	0	0	0	0	0	0	0	0	0.5

Table 6.3 shows the uncertain preferences of CG over the feasible states. CG is eager to see that PO and D reach an agreement, and that the Kaufman Factory brownfield be remediated. In this way, threats of hazardous waste will be removed and tax income will increase with the new development. As a result, states s_8 to s_{10} are highly preferred over the others. Because CG cares about the success of the transaction, it prefers that PO sells the property at a low price, which makes it easier for D to accept. Then, s_8 is less preferred than s_9 , and s_{11} is less preferred than s_{12} . Whether CG would like to offer extra incentives also depends on the degree of pollution. If the property is highly polluted, leading to potential liability risk and extra remediation costs, CG needs to take up the duties and share the responsibilities with D, otherwise D will not be engaged in this situation; if the

property is only somewhat polluted, CG hopes D can handle it. Hence, combinations of intervals are used to represent preference relations between s_9 and s_{10} , s_8 and s_{10} , s_8 and s_{11} as well as s_9 and s_{11} . States s_1 to s_7 indicate that an agreement cannot be reached. In these situations, CG prefers that PO sells the property at a low price and offers reasonable incentives to persuade D to accept the deal. Uncertain preferences are applied to represent the CG's concerns.

Table 6.4: Grey Preference Matrices of D

DM	Grey preference matrices											
	s_1	s_2	s_3	s_4	s_5	s_6	s_7	s_8	s_9	s_{10}	s_{11}	s_{12}
s_1	0.5	0.5	0	0	0	0	0.8	1	0	0	0	1
s_2	0.5	0.5	0	0	0	0	0.7	1	0	0	0	1
s_3	1	1	0.5	[0.6,0.7]	[0.5,0.7]	0	1	1	0	0	0	1
s_4	1	1	[0.3,0.4]	0.5	0.5	0	1	1	0	0	0	1
s_5	1	1	[0.3,0.5]	0.5	0.5	0	1	1	0	0.2	0	1
s_6	1	1	1	1	1	0.5	1	1	1	1	0	1
s_7	0.2	0.3	0	0	0	0	0.5	1	0	0	0	1
s_8	0	0	0	0	0	0	0	0.5	0	0	0	0
s_9	1	1	1	1	1	0	1	1	0.5	[0.5,0.7]	0	1
s_{10}	1	1	1	1	0.8	0	1	1	[0.3,0.5]	0.5	0	1
s_{11}	1	1	1	1	1	1	1	1	1	1	0.5	1
s_{12}	0	0	0	0	0	0	0	1	0	0	0	0.5

Considering the convenient location of the property and the prosperous future of the community, the redevelopment of this area is attractive to D. s_{11} is obviously the most preferred state for D, because he buys the property at a low price and also gets incentives from CG. The uncertain preference for state s_9 over s_{10} depends on whether the lower price or the incentives are more beneficial. Generally, the incentives provided by CG are indirect, like fee rebates and tax deduction, so a lower price from PO is likely more preferred. On the contrary, the least preferred situation for D is PO insisting on selling at a high price with no support offered from CG. In this circumstance, D might choose to back out of the

Table 6.5: Grey Relative Preference Matrices of PO

DM	Grey Relative certainty of Preference for PO												
	s_1	s_2	s_3	s_4	s_5	s_6	s_7	s_8	s_9	s_{10}	s_{11}	s_{12}	
r^{PO}	s_1	0	0	1	-0.2	-0.4	1	-0.6	-1	1	-1	0.8	0.6
	s_2	0	0	1	-0.2	-0.4	1	-0.6	-1	1	-1	0.8	0.6
	s_3	-1	-1	0	-0.6	-1	1	-0.6	-1	1	-1	0.6	0.4
	s_4	0.2	0.2	0.6	0	-0.4	0.2	-0.4	-1	1	-1	1	0.6
	s_5	0.4	0.4	1	0.4	0	1	-0.6	-1	1	-1	1	0.6
	s_6	-1	-1	-1	-0.2	-1	0	-1	-1	1	-1	1	0.2
	s_7	0.6	0.6	0.6	0.4	0.6	1	0	-1	1	-1	1	1
	s_8	1	1	1	1	1	1	1	0	1	[-0.6,-0.2]	1	1
	s_9	-1	-1	-1	-1	-1	-1	-1	-1	0	-1	-0.2	[-0.6,-0.4]
	s_{10}	1	1	1	1	1	1	1	[0.2,0.6]	1	0	1	1
	s_{11}	-0.8	-0.8	-0.6	-1	-1	-1	-1	-1	-0.6	-1	0	[-0.4,0.2]
	s_{12}	-0.6	-0.6	-0.4	-0.6	-0.6	-0.2	-1	-1	[0.4,0.6]	-1	[0.2,0.4]	0

negotiation. For the middle states from s_1 to s_7 , D is indifferent whether PO refuses to sell or insists on a high price, so s_1 is equally preferred to s_2 . The preference for s_3 over s_5 is similar to that for s_9 over s_{10} . s_6 is highly preferred, because D already gets a desirable outcome, but is still in negotiation with PO and CG with the purpose of achieving more benefits. However, s_7 , in which D shows his sincerity but receives no response from CG and PO, is less preferred.

Based on the inferred grey preferences, the grey relative certainty of preference (GRCP) for PO, CG, and D can be calculated according to (5.3), separately. After the transformation, the uncertain preference for each of the three DMs is represented by GRCP. The value 0 means the pair of states are equally preferred. The positive preferences, ranging from 0 to 1 mean that the states in the rows are likely more preferred than those in the columns. On the contrary, the negative preferences, ranging from -1 to 0 mean the states in the rows are likely less preferred than those in the columns. The value of -1 means not preferred, and that of 1 means preferred. Compared with grey preferences, it is easier to tell the preference relationship over feasible states through the GRCP.

Table 6.6: Grey Relative Preference Matrices of CG

DM	Grey Relative certainty of Preference for CG												
	s_1	s_2	s_3	s_4	s_5	s_6	s_7	s_8	s_9	s_{10}	s_{11}	s_{12}	
r^{CG}	s_1	0	0.2	-0.2	-0.4	-0.2	-0.6	-0.4	-1	-1	-1	-1	1
	s_2	-0.2	0	-0.4	-0.6	-0.2	-0.6	-0.2	-1	-1	-1	-1	1
	s_3	0.2	0.4	0	-0.2	0.2	-0.2	-0.2	-1	1	-1	-1	1
	s_4	0.4	0.6	0.2	0	0.2	-0.4	-0.2	-1	1	-1	-1	1
	s_5	0.2	0.2	-0.2	-0.2	0	-0.6	-0.4	-1	1	-1	-1	1
	s_6	0.6	0.6	0.2	0.4	0.6	0	0	-1	1	-1	-1	1
	s_7	0.4	0.2	0.2	0.2	0.4	0	0	-1	1	-1	-1	1
	s_8	1	1	1	1	1	1	0	[0,0.4]		[-0.2,0.6]	[-0.4,0.8]	1
	s_9	1	1	1	1	1	1	[-0.4,0]	0	{[-0.8,0.1][0.2,0.4]}	[-0.2,0.6]	[-0.4,0]	1
	s_{10}	1	1	1	1	1	1	[-0.6,0.2]	{[-0.4,-0.2][-0.1,0.8]}	0	[-0.4,0]	[-0.4,0]	1
	s_{11}	1	1	1	1	1	1	[-0.8,0.4]	[-0.6,0.2]	[0,0.4]	0	0	1
	s_{12}	-1	-1	-1	-1	-1	-1	-1	-1	-1	-1	-1	0

Table 6.7: Grey Relative Preference Matrices of D

DM	Grey Relative certainty of Preference for D												
	s_1	s_2	s_3	s_4	s_5	s_6	s_7	s_8	s_9	s_{10}	s_{11}	s_{12}	
r^D	s_1	0	0	-1	-1	-1	-1	0.6	1	-1	-1	-1	1
	s_2	0	0	-1	-1	-1	-1	0.4	1	-1	-1	-1	1
	s_3	1	1	0	[0.2,0.4]	[0,0.4]	-1	1	1	-1	-1	-1	1
	s_4	1	1	[-0.4,-0.2]	0	0	0	1	1	-1	-1	-1	1
	s_5	1	1	[-0.4,0]	0	0	-1	1	1	-1	-0.6	-1	1
	s_6	1	1	1	1	1	0	1	1	1	1	-1	1
	s_7	-0.6	-0.4	-1	-1	-1	-1	0	1	-1	-1	-1	1
	s_8	-1	-1	-1	-1	-1	-1	-1	0	-1	-1	-1	-1
	s_9	1	1	1	1	1	-1	1	1	0	[0,0.4]	-1	1
	s_{10}	1	1	1	1	0.6	-1	1	1	[-0.4,0]	0	-1	1
	s_{11}	1	1	1	1	1	1	1	1	1	1	0	1
	s_{12}	-1	-1	-1	-1	-1	-1	-1	1	-1	-1	-1	0

6.2.3 Stability Analysis of the Brownfield Redevelopment Conflict

Grey stability analysis can be carried out only after DMs' characteristics have been identified. In this conflict, after the bankruptcy of Kaufman Footwear, PO is eager to sell the property at a high price; D needs a comprehensive estimate in order to make a wise choice; and CG is neutral about incentives. Hence, it is reasonable to assume that the characteristics of these three DMs are: PO optimistic, D pessimistic, and CG neutral. Based on the characteristics of the DMs, the AP for each DM can be calculated according to (5.5), (5.6), and (5.7), and the results are as shown in Table 6.8.

In the conflict, based on the unilateral moves of DMs in the conflict, shown in Figure 6.3, the Figures 6.4, 6.5, and 6.6 are drawn to reflect how GUIs for each DM depend on the GSTs. In the directed graph shown in Figure 6.4, the color-coded arrows represent unilateral improvements of PO holding different GSTs, and indifferent states are connected by a double black line. For example, the blue arrows represent unilateral improvements of PO when his GST is in the range $(0.2, 0.4]$, such as s_5 is a GUI from state s_4 for him. PO's GST is classified into 3 different ranges according to his unilateral moves (see Figure 6.3), and anticipated preferences, which are determined by his characteristic and grey relative preferences, (see Table 6.5). Note that classifying DM's GST is to facilitate a grey stability analysis. For instance, when the GST falls into a lower range, the GUIs requiring higher range of GST are also valid. In particular, if PO's GST is equal to 0.1, the states directed by black, blue and red are all GUIs from their corresponding initial vertices. The directed graph indicates that the GUIs of PO can change a great deal when his GST changes.

In the directed graph shown in Figure 6.4, the arrows with different colours represent unilateral improvements of PO holding different GSTs, and indifferent states are connected

Table 6.8: Anticipated Preferences of the Decision Makers in the Conflict

DMs		Grey Relative certainty of Preference for PO											
		s_1	s_2	s_3	s_4	s_5	s_6	s_7	s_8	s_9	s_{10}	s_{11}	s_{12}
AP^{PO}	s_1	0	0	1	-0.2	-0.4	1	-0.6	-1	1	-1	0.8	0.6
	s_2	0	0	1	-0.2	-0.4	1	-0.6	-1	1	-1	0.8	0.6
	s_3	-1	-1	0	-0.6	-1	1	-0.6	-1	1	-1	0.6	0.4
	s_4	0.2	0.2	0.6	0	-0.4	0.2	-0.4	-1	1	-1	1	0.6
	s_5	0.4	0.4	1	0.4	0	1	-0.6	-1	1	-1	1	0.6
	s_6	-1	-1	-1	-0.2	-1	0	-1	-1	1	-1	1	0.2
	s_7	0.6	0.6	0.6	0.4	0.6	1	0	-1	1	-1	1	1
	s_8	1	1	1	1	1	1	1	0	1	-0.2	1	1
	s_9	-1	-1	-1	-1	-1	-1	-1	-1	0	-1	-0.2	-0.4
	s_{10}	1	1	1	1	1	1	1	0.6	1	0	1	1
	s_{11}	-0.8	-0.8	-0.6	-1	-1	-1	-1	-1	-0.6	-1	0	0.2
	s_{12}	-0.6	-0.6	-0.4	-0.6	-0.6	-0.2	-1	-1	0.6	-1	0.4	0
		Grey Relative certainty of Preference for CG											
AP^{CG}	s_1	0	0.2	-0.2	-0.4	-0.2	-0.6	-0.4	-1	-1	-1	-1	1
	s_2	-0.2	0	-0.4	-0.6	-0.2	-0.6	-0.2	-1	-1	-1	-1	1
	s_3	0.2	0.4	0	-0.2	0.2	-0.2	-0.2	-1	1	-1	-1	1
	s_4	0.4	0.6	0.2	0	0.2	-0.4	-0.2	-1	1	-1	-1	1
	s_5	0.2	0.2	-0.2	-0.2	0	-0.6	-0.4	-1	1	-1	-1	1
	s_6	0.6	0.6	0.2	0.4	0.6	0	0	-1	1	-1	-1	1
	s_7	0.4	0.2	0.2	0.2	0.4	0	0	-1	1	-1	-1	1
	s_8	1	1	1	1	1	1	1	0	0.2	0.2	0.2	1
	s_9	1	1	1	1	1	1	1	-0.2	0	-0.23	0.2	1
	s_{10}	1	1	1	1	1	1	1	-0.2	0.23	0	0.2	1
	s_{11}	1	1	1	1	1	1	1	-0.2	-0.2	0.2	0	1
	s_{12}	-1	-1	-1	-1	-1	-1	-1	-1	-1	-1	-1	0
		Grey Relative certainty of Preference for D											
AP^D	s_1	0	0	-1	-1	-1	-1	0.6	1	-1	-1	-1	1
	s_2	0	0	-1	-1	-1	-1	0.4	1	-1	-1	-1	1
	s_3	1	1	0	0.2	0	-1	1	1	-1	-1	-1	1
	s_4	1	1	-0.4	0	0	0	1	1	-1	-1	-1	1
	s_5	1	1	-0.4	0	0	-1	1	1	-1	-0.6	-1	1
	s_6	1	1	1	1	1	0	1	1	1	1	-1	1
	s_7	-0.6	-0.4	-1	-1	-1	-1	0	1	-1	-1	-1	1
	s_8	-1	-1	-1	-1	-1	-1	-1	0	-1	-1	-1	-1
	s_9	1	1	1	1	1	-1	1	1	0	0	-1	1
	s_{10}	1	1	1	1	0.6	-1	1	1	-0.4	0	-1	1
	s_{11}	1	1	1	1	1	1	1	1	1	1	0	1
	s_{12}	-1	-1	-1	-1	-1	-1	-1	1	-1	-1	-1	0

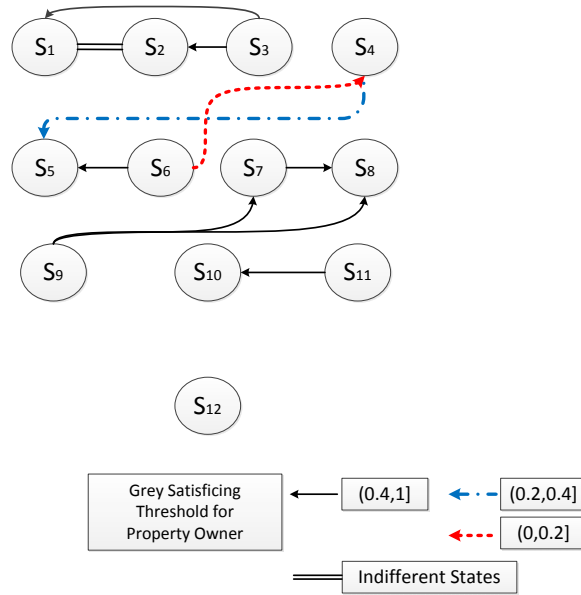

Figure 6.4: Directed Graph for PO Holding Different Grey Satisficing Thresholds

by a double black line. For example, the blue arrows represent unilateral improvements of PO when his GST is in the range $(0.2, 0.4]$, such as his unilateral improvements from state s_4 to s_5 . PO's GST is classified into 3 different ranges according to his unilateral moves (see Figure 6.3), and anticipated preferences, which are determined by his characteristic, grey relative preferences, (see Table 6.5). Note that to classify DM's GST is to facilitate a grey stability analysis. For instance, when the GST falls into a lower range, the unilateral improvements requiring higher range of GST are also valid. In particular, if PO's GST is equal to 0.1, the states directed by black, blue and red are all unilateral improvements for their corresponding initial vertices. The directed graph indicates that the unilateral improvements of PO can change a great deal when his GST changes.

In Figure 6.5, two colours of arrow represent the GUIs of D when his GST falls into the range of $(0, 0.6]$ or $(0.6, 1]$. Specifically, s_7 is a GUI from s_1 only when his GST is at most

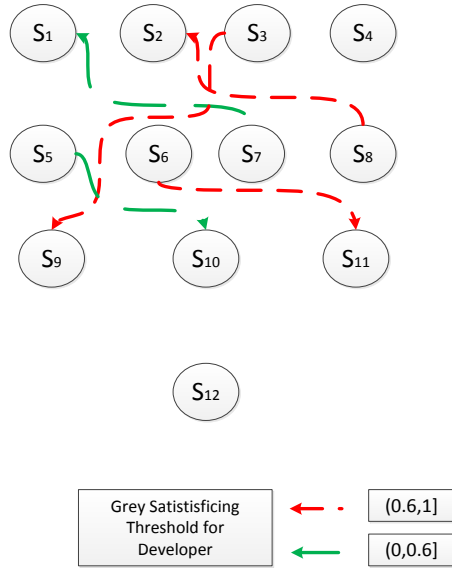

Figure 6.5: Directed Graph for D Holding Different Grey Satisficing Thretholds

0.6, (see Table 6.7); for the other GUIs, indicated by red arrows, the relationship between each pair of states is a strict preference. Hence, these GUIs do not change with D’s GST. D is concerned about his investment, and will move only to states that are preferred with high confidence, which is consistent with his characteristic. In Figure 6.6, GUIs for CG are indicated by blue and purple arrows according to the GST. These GUIs are valid only when CG’s GST is relatively low.

After the identification of GUIs for PO, D and CG, respectively, stable states of the Kaufman brownfield redevelopment conflict under uncertainty can be determined. Three sets of GSTs for PO, D and CG are assumed, which are $\{0.8, 1, 0.6\}$, $\{0.5, 0.8, 0.4\}$, $\{0.2, 0.6, 0.2\}$. The stability results based on the stability definitions are displayed in Table 6.9. In this table, a state that is stable for PO, D and CG is marked \checkmark under corresponding grey stability definitions, while GE indicates that the state is stable for all DMs.

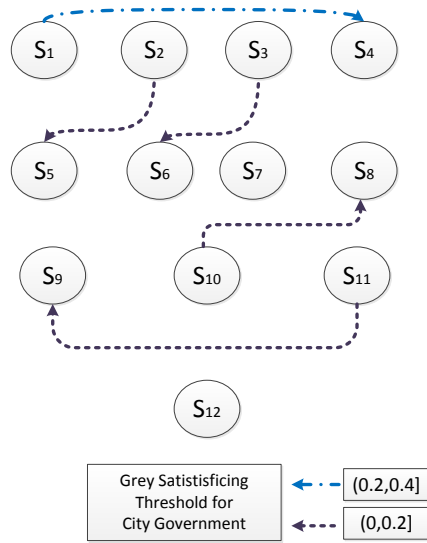

Figure 6.6: Directed Graph for CG Holding Different Grey Satisficing Thretholds

Note that both D and PO can unilaterally abandon the transaction, and any unilateral move for PO or D to s_{12} is irreversible, so the state s_{12} is grey Nash stable for all DMs, thereby grey sequentially stable. Moreover, a GUI from any state except for s_{12} of any DM can be sanctioned by the other two DMs through moving the conflict to state s_{12} . Hence, all states for all the DMs are grey symmetric metarational and grey general metarational (Kuang et al., 2014a). Thus, these two types of stability definitions are meaningless in the conflict analysis, and are not discussed in this case study.

In this conflict, the focal DM's GUIs from an initial state can only be sanctioned by the other DMs' GUIs. In order to interpret the stability results, GUIs for the DMs in three sets of GSTs are drawn as shown in Figures 6.7, 6.8 and 6.9. In these Figures, a GUI from a initial state is directed by a black arrow. The GUIs from corresponding initial states within green frames opposite a DM can be sanctioned by the other DMs' GUIs, which are connected by red arrows. Then the initial states are called grey sequentially stable. For

Table 6.9: Stability Results for Brownfield Redevelopment Conflict under Uncertainty

GST: Property Owner = 0.1, Developer = 0.6, City Government = 0.2													
States		s_1	s_2	s_3	s_4	s_5	s_6	s_7	s_8	s_9	s_{10}	s_{11}	s_{12}
GR	PO	✓	✓			✓			✓		✓		✓
	D	✓	✓		✓					✓	✓	✓	✓
	CG				✓	✓	✓	✓	✓	✓			✓
GSEQ	PO	✓	✓			✓		✓	✓		✓		✓
	D	✓	✓	✓	✓	✓				✓	✓	✓	✓
	CG				✓	✓	✓	✓	✓	✓	✓	✓	✓
GE					✓					✓		✓	
GST: Property Owner = 0.9, Developer = 0.6, City Government = 0.2													
GR	PO	✓	✓			✓			✓		✓		✓
	D	✓	✓		✓	✓		✓		✓	✓	✓	✓
	CG		✓	✓		✓	✓	✓	✓	✓	✓	✓	✓
GSEQ	PO	✓	✓			✓			✓		✓	✓	✓
	D	✓	✓		✓	✓		✓		✓	✓	✓	✓
	CG		✓	✓		✓	✓	✓	✓	✓	✓	✓	✓
GE					✓					✓	✓	✓	
GST: Property Owner = 0.8, Developer = 1, City Government = 0.6													
GR	PO	✓	✓		✓	✓			✓		✓		✓
	D	✓	✓		✓	✓		✓		✓	✓	✓	✓
	CG		✓	✓	✓	✓	✓	✓	✓	✓	✓	✓	✓
GSEQ	PO	✓	✓		✓	✓			✓		✓		✓
	D	✓	✓	✓	✓	✓		✓		✓	✓	✓	✓
	CG		✓	✓	✓	✓	✓	✓	✓	✓	✓	✓	✓
GE		✓			✓	✓				✓		✓	

example, in Figure 6.7, if D unilaterally moves the conflict from s_3 to s_9 , then PO would prefer to move from s_9 to s_7 or s_8 , both of which are less preferred than s_3 by D. Hence s_3 is grey sequentially stable for D. Note that the states that do not have GUIs are grey Nash stable for the DM, such as s_1 and s_2 for PO.

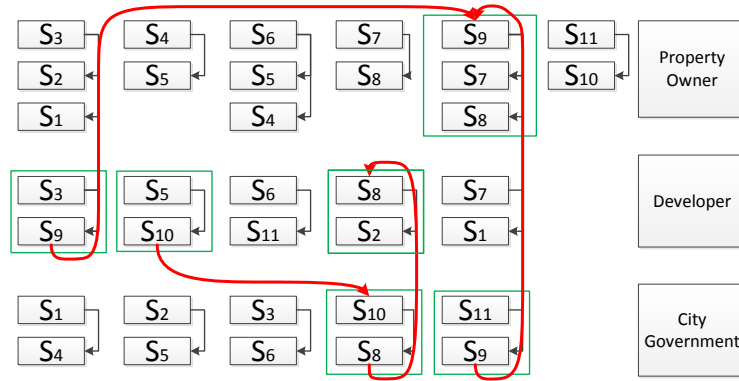

Figure 6.7: Grey Unilateral Improvements and Potential Sanctions (GST: PO = 0.1, D = 0.6, CG = 0.2)

The first situation (GST: PO = 0.1, D = 0.6, CG = 0.2), as shown in Figure 6.7, has the most GUIs for each DM, because of their corresponding lowest GSTs. Three states s_5 , s_{10} , and s_{12} are equilibria. Among them, s_5 and s_{12} are grey Nash stable, while s_{10} is grey sequentially stable. Specifically, none of the DMs has GUIs from state s_5 and s_{12} . s_{10} is grey Nash stable for PO and D, and grey sequentially stable for CG. If CG chooses to unilaterally move from s_{10} to s_8 , then D can unilaterally move the conflict from s_8 to s_2 . However, according to the anticipated preferences of CG and its GST, s_2 is less preferred than s_{10} . To avoid ruining the transaction, CG will stay in state s_{10} .

In the second situation (GST: PO = 0.9, D = 0.6, CG = 0.2), as shown in Figure 6.8, the number of PO's GUIs decreases when his GST increases, some of PO's GUIs, such as his movements from s_4 to s_5 , and from s_6 to s_4 , in the first situation are no longer

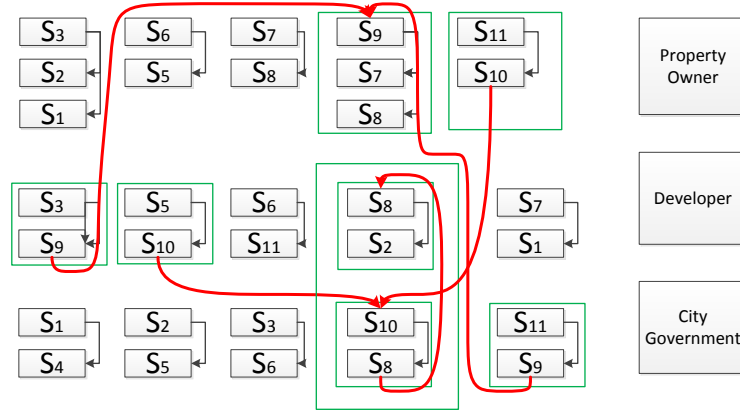

Figure 6.8: Grey Unilateral Improvements and Potential Sanctions for DMs (GST: PO = 0.1, D = 0.6, CG = 0.2)

unilateral improvements. Therefore, s_4 becomes grey Nash stable for PO in this situation. After that, s_{11} becomes an equilibrium. Specifically, s_{11} is grey Nash stable for D, and is grey sequentially stable for CG. If the PO wants to ask a high price when CG decides to offer incentives and D is willing to buy this property, then PO can unilaterally move the conflict from state s_{11} to s_{10} . However, CG can sanction PO's movement by withdrawing the incentives and move the conflict from s_{10} to s_8 , and D would refuse to buy and move from s_8 to s_2 . According to CG's GST and its uncertain preference, s_2 is less preferred than s_{11} . Hence, s_{11} is also grey sequentially stable for PO, thereby a equilibrium for the conflict.

In the third situation (GST: PO = 0.9, D = 0.8, CG = 0.6), as shown in Figure 6.9, D's and CG's GUIs decrease when their GSTs increase. As CG's GUIs decrease, some grey sequentially stable states in the other two situations are no longer stable. However, more states become grey Nash stable for their corresponding DM. The grey Nash stable states are: $s_1, s_2, s_4, s_5, s_8, s_{10}$, and s_{12} for PO; $s_1, s_2, s_4, s_5, s_7, s_9, s_{10}, s_{11}$, and s_{12} for D; and

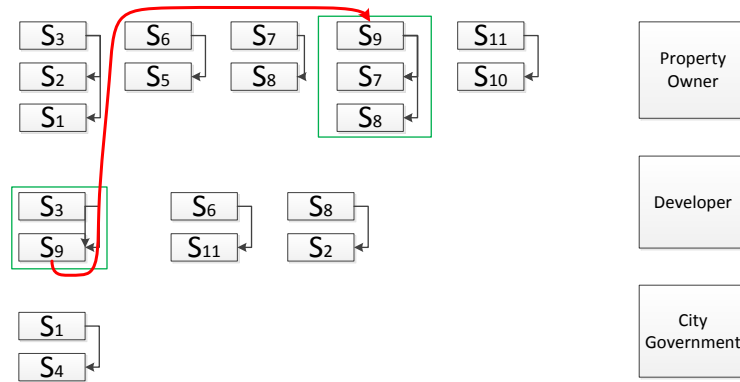

Figure 6.9: Grey Unilateral Improvements and Potential Sanctions for DMs (GST: PO = 0.9, D = 0.8, CG = 0.6)

all states except s_1 for CG. Hence, $s_1, s_2, s_4, s_5, s_{10}$, and s_{12} are equilibria for the conflict in this situation.

6.2.4 Status Quo Analysis

Through the stability analysis, equilibria have been found in the graph model for brown-field redevelopment conflict, when DMs' uncertain preferences are considered. Among them, two states s_{10} and s_{11} , indicating the completion of the transaction, are found to be equilibria under corresponding situations. A status quo analysis is carried out, in order to dynamically examine whether they are reachable from the status quo in reality, to access which equilibrium is more likely to happen, and to explore how these equilibria can be reached, thereby providing insights of the conflict on how to achieve desirable stable states for DMs. In this conflict, s_1 is the status quo state, and the potential evolutions involve moves from s_1 to equilibria s_{10} and s_{11} , as shown in Table 6.10.

Table 6.10 shows how equilibria s_{10} and s_{11} are reached from status quo s_1 through

Table 6.10: Status Quo Analysis

DMs	Status Quo	Transitional states			Equilibria	
PO	N	N	→	Y	Y	
	N	N		N	N	
	N	N		N	N	
CG	N	→	Y	Y	Y	
D	N	N		N	→	Y
	N	N		N		N
States	s_1	s_4		s_5	s_{10}	
PO	N	N		N	N	
	N	→	Y	Y	Y	
	N	N		N	N	
CG	N	N	→	Y	Y	
D	N	N		N	→	Y
	N	N		N		N
States	s_1	s_3		s_6	s_{11}	

transitional states by corresponding DMs. Based on the stability analysis, the focal DM's GUIs from a initial state can be sanctioned only by the other DMs' GUIs, which means none of the DMs will sanction the other DMs' GUIs by sacrificing his benefits. s_{10} is reachable only when s_4 is a GUI from s_1 for CG, s_5 is a GUI from s_4 for PO, and s_{10} is a GUI from s_5 for D. In this circumstance, according to the directed graphs for DMs holding different GSTs, shown in Figures 6.4, 6.5 and 6.6, the GSTs for DMs should be $0 < \gamma_{CG} \leq 0.2$, $0 < \gamma_{PO} \leq 0.4$, and $0 < \gamma_D \leq 0.6$, respectively. To achieve mutual benefit results, all DMs need to compromise their GSTs, and CG plays a key role in facilitating the transaction. However, s_{11} is hard to reach. Even though s_6 can be a GUI from s_3 for CG when $0 < \gamma_{CG} \leq 0.2$, and s_{11} is a GUI from s_6 for D, s_3 is not preferred by PO compared with s_1 who will not reduce the price of the property at the beginning of the conflict, unless he is extremely short of money. As a result, s_{10} is more likely to happen.

6.3 Conclusions

This research, using grey numbers to express uncertain preferences of DMs, aims to define grey-based stability concepts and corresponding equilibria within the GMCR structure when multiple DMs are involved in a conflict, thereby extending the graph model methodology. These definitions can account for missing preference information in a multiple participant-multiple objective decision model, and therefore, provide more realistic resolutions to a conflict being studied in the face of uncertainty.

This methodology is applied to a brownfield redevelopment conflict that occurred in Kitchener, Ontario, Canada, in which DMs have uncertain preferences. The directed graphs for DMs holding different GSTs are drawn. Based on three sets of GSTs for DMs, GUIs and potential sanctions for each DM are also provided, and then stability results are calculated according to two types of grey stability concepts (grey Nash stability, and grey sequential stability). Subsequently, further interpretation of these equilibria is given, with an explanation of how equilibria will change when DMs' GSTs are altered. A status quo analysis is also carried out to assess which equilibria are reachable from the status quo and which one is most likely to occur in the actual conflict.

Chapter 7

Contributions and Future Research

This research presents the concept of grey numbers, and then integrates them with techniques in the fields of Multiple Criteria Decision Analysis (MCDA) and Graph Model for Conflict Resolution (GMCR). Two methodologies, grey-based PROMETHEE II and grey-based GMCR, are put forward, and some practical applications are investigated using these novel techniques. The main contributions and suggestions for future research of this thesis are summarised in the following two sections.

7.1 Main Contributions

The key contributions of this thesis are summarised as follows:

- In Chapter 2, the classification of main stream MCDA methodologies and some representative techniques are presented. Subsequently, the decision structure and calculation processes for PROMETHEE II are explained in detail. Moreover, a sys-

tematic introduction of fundamental concepts and theorems of grey systems theory are given, followed by a mathematical illustration of grey relational analysis.

- The grey-based PROMETHEE II methodology is put forward in Chapter 3 to handle MCDA problems with ill-defined information, using the concept of grey numbers to represent uncertain input data, and employing linguistic expressions combined with grey numbers to express DMs' preferences on alternatives. In the methodology, a basic structure of a grey decision system is constructed, in which multiple alternatives, criteria and DMs are taken into account. Then, calculation processes are introduced to normalize performance of alternatives on both quantitative and qualitative criteria. In addition, a preference measurement function is designed to evaluate the preference degree of one alternative over another, and the PROMETHEE II method is modified for accomplishing ranking alternatives with normalized performances.
- A case study in Chapter 3 regarding the evaluation of source water protection strategies in Region of Waterloo, Ontario, Canada, is introduced to demonstrate how to apply the grey-based PROMETHEE II methodology. The results show that the methodology can provide a complete ranking order of alternatives having uncertain information.
- In Chapter 4, mathematical definitions and solution concepts within the context of GMCR are summarised. To illustrate the process of employing conflict analysis within the framework of graph model, a case study regarding a conflict over water use and oil sands development in the Athabasca River among three DMs: Oils Sands Companies, Local Government, and NGOs, is put forward. Through a thorough stability analysis, the results indicate that it is possible to balance oil sands development and environmental protection, whereby the sustainable development of the oil sands

industry requires the collaboration of all DMs.

- A new preference structure based on general grey numbers is introduced in Chapter 5. A generalized grey number with values ranging from 0 to 1, may represent a preference degree, interval of preference degrees, or combinations thereof, and this concept is used to capture preference uncertainty between two states by a DM. The grey preference structure allows DMs to describe preferences with generalized grey numbers, in addition to strict preference and indifference. A number of grey-based concepts within the framework of GMCR are formally defined, such as grey preference degrees, grey relative certainty of preferences, anticipated preferences, grey satisficing threshold, and grey unilateral improvements.
- Grey-based stability definitions based on the grey preference structure are put forward to identify stable states or equilibria when two DMs are involved in a conflict with uncertain preferences in Chapter 5. Specifically, grey Nash stability, grey general metarationality, grey symmetric metarationality, and grey sequential stability are formally defined along with associated theorems, and corresponding explanations are provided. Furthermore, a case study involving a sustainable development conflict under uncertainty, is developed to illustrate how this methodology can be utilized to analyze a practical conflict when DMs have uncertain preferences.
- In Chapter 6, the grey-based GMCR methodology is further explored to deal with conflicts having two or more DMs. In this circumstance, coordinated unilateral moves and unilateral improvements of multiple DMs have been defined under the grey-based uncertain preference structure. Then the aforementioned four kinds of grey stabilities are modified to be suitable for employment with a grey-based conflict model having two or more DMs. The feasibility of this methodology is verified through a case study

regarding negotiations in a brownfield redevelopment conflict under uncertainty in Kitchener, Ontario, Canada.

In summary, this thesis lays down the foundation of new methodologies for handling uncertain decision problems within the frameworks of MCDA and GMCR. The research involves both theoretical developments coupled with real-world case studies.

7.2 Future Research Plan

The methodologies proposed in this thesis can be further refined and expanded in the fields of MCDA and GMCR. Some possible directions for future research are as follows:

- Grey-based methods can be developed for screening, and eliminating alternatives in the field of MCDA based on the fundamental concepts of grey systems theory.
- In the thesis, a grey preference structure was incorporated into GMCR, thereby allowing DMs to represent their preferences in a flexible way. However, it raises complexity in calculating grey-based stable states. Accordingly, a decision support system should be developed for permitting convenient implementation by both practitioners and researchers.
- The grey preference structure could be employed to help understand processes of group decision and negotiation.
- The grey-based GMCR methodology focuses only on the four basic stability definitions. Complex solution concepts, such as limited move stability and non-myopic stability, may be further studied in the future from a grey perspective.

- The presented methodologies can be further refined and modified by analysing more real-world applications in an attempt to provide more insights and reasonable suggestions for DMs to consider.

References

- Agell, N., Sánchez, M., Prats, F., and Roselló, L. (2012). Ranking multi-attribute alternatives on the basis of linguistic labels in group decisions. *Information Sciences*, 209:49–60.
- Alberta Department of Energy (2013). Talk about oil sands. Technical report. Available: http://www.energy.alberta.ca/oilsands/pdfs/factsheet_oilsands.pdf.
- Alberta Environment and Fisheries and Oceans Canada (2007). Water management framework: In stream flow needs and water management system for the lower athabasca river. Technical report. Available: http://environment.alberta.ca/documents/athabasca_rwmf_technical.pdf.
- Alberta Environment and Fisheries and Oceans Canada (2013). Re: Oil sands mining water management agreement for the 2013—2014 winter period. Technical report. Available: <http://esrd.alberta.ca/water/programs-and-services/river-management-frameworks/documents/OilSandsMiningWaterMgmtAgmt2013-2014Final.pdf>.
- Alonso, S., Herrera-Viedma, E., Chiclana, F., and Herrera, F. (2010). A web based consensus support system for group decision making problems and incomplete preferences. *Information Sciences*, 180(23):4477–4495.
- Bai, C. and Sarkis, J. (2010). Integrating sustainability into supplier selection with grey system and rough set methodologies. *International Journal of Production Economics*, 124(1):252–264.
- Baron, J. (2000). *Thinking and deciding*. Cambridge University Press.
- Bashar, M. A., Kilgour, D. M., and Hipel, K. W. (2012). Fuzzy preferences in the graph model for conflict resolution. *IEEE Transactions on Fuzzy Systems*, 20(4):760–770.

- Behzadian, M., Kazemzadeh, R., Albadvi, A., and Aghdasi, M. (2010). Promethee: A comprehensive literature review on methodologies and applications. *European Journal of Operational Research*, 200(1):198–215.
- Belton, V. and Pictet, J. (1997). A framework for group decision using a MCDA model: Sharing, aggregating or comparing individual information? *Journal of Decision Systems*, 6(3):283–303.
- Belton, V. and Stewart, T. J. (2002). *Multiple Criteria Decision Analysis: An Integrated Approach*. Springer, Kluwer, Dordrecht.
- Ben-Haim, Y. and Hipel, K. W. (2002). The graph model for conflict resolution with information-gap uncertainty in preferences. *Applied Mathematics and Computation*, 126(2):319–340.
- Bernath Walker, S., Boutilier, T., and Hipel, K. W. (2010). Systems management study of a private brownfield renovation. *Journal of Urban Planning and Development*, 136(3):249–260.
- Bodily, S. E. (1979). Note-a delegation process for combining individual utility functions. *Management Science*, 25(10):1035–1041.
- Brans, J. P. (2006). The space of freedom of the decision maker modelling the human brain. *European Journal of Operational Research*, 92(3):593–602.
- Brans, J. P. and Mareschal, B. (1995). The PROMETHEE VI procedure: how to differentiate hard from soft multicriteria problems. *Journal of Decision Systems*, 4(3):213–223.
- Brans, J. P. and Mareschal, B. (2005). PROMETHEE methods. In Figueira, J., Greco, S., and Ehrgott, M., editors, *Multiple Criteria Decision Analysis: State of the Art Surveys*, pages 163–186. Springer New York.
- Brans, J. P., Vincke, P., and Mareschal, B. (1986). How to select and how to rank projects: The PROMETHEE method. *European Journal of Operational Research*, 24(2):228–238.
- Caferra, R. and Peltier, N. (2008). Accepting/rejecting propositions from accepted/rejected propositions: A unifying overview. *International Journal of Intelligent Systems*, 23(10):999–1020.
- Calizay, A., Meixner, O., Bengtsson, L., and Berndtsson, R. (2010). Multi-criteria decision analysis (MCDA) for integrated water resources management (IWRM) in the Lake Poopo Basin, Bolivia. *Water Resources Management*, 24(10):2267–2289.

- Canadian Association of Petroleum Producers (2011). Public opinion research on oil sands. Technical report. Available: <http://www.capp.ca/canadaIndustry/oilSands/Dialogue-Resources/research/Pages/default.aspx>.
- Canadian Association of Petroleum Producers (2012). Water use in canada's oil sands. Technical report. Available: <http://www.capp.ca/getdoc.aspx?Docid=193756>.
- Canadian Association of Petroleum Producers (2013). The facts on oil sands. Technical report. Available: <http://www.capp.ca/getdoc.aspx?DocId=242473&DT=NTV>.
- Carlsson, C. and Fullér, R. (1996). Fuzzy multiple criteria decision making: Recent developments. *Fuzzy Sets and Systems*, 78(2):139–153.
- Chan, J. W. and Tong, T. K. (2007). Multi-criteria material selections and end-of-life product strategy: Grey relational analysis approach. *Materials and Design*, 28(5):1539–1546.
- Chang, E. C., Sanna, L. J., and Yang, K.-M. (2003). Optimism, pessimism, affectivity, and psychological adjustment in US and Korea: a test of a mediation model. *Personality and Individual Differences*, 34(7):1195–1208.
- Chang, F.-J., Hui, S.-C., and Chen, Y.-C. (2002). Reservoir operation using grey fuzzy stochastic dynamic programming. *Hydrological Processes*, 16(12):2395–2408.
- Chang, T. and Lin, S. (1999). Grey relation analysis of carbon dioxide emissions from industrial production and energy uses in taiwan. *Journal of Environmental Management*, 56(4):247–257.
- Charnes, A. and Cooper, W. (1977). Goal programming and multiple objective optimizations: Part 1. *European Journal of Operational Research*, 1(1):39–54.
- Checkland, P. (1981). *Systems thinking, systems practice*. Wiley, Chichester, United Kingdom.
- Chen, S.-J., Hwang, C. L. C., and Hwang, F. (1992). *Fuzzy Multiple Attribute Decision Making : Methods and Applications*. Springer-Verlag, Berlin.
- Chen, T.-Y. (2011). A multimeasure approach to optimism and pessimism in multiple criteria decision analysis based on atanassov fuzzy sets. *Expert Systems with Applications*, 38(10):12569–12584.

- Chen, Y., Hipel, K. W., and Kilgour, D. (2007). Multiple criteria sorting using case-based distance model with an application in water resource management. *IEEE Systems, Man, and Cybernetics Society*, 37(5):680–691.
- Coello, C. A. C., Lamont, G. B., and Veldhuizen, D. A. V. (2007). *Evolutionary Algorithms for Solving Multi-objective Problems*. Springer, New York.
- Comes, T., Hiete, M., Wijngaards, N., and Schultmann, F. (2011). Decision maps: A framework for multi-criteria decision support under severe uncertainty. *Decision Support Systems*, 52(1):108–118.
- Damart, S., Dias, L. C., and Mousseau, V. (2007). Supporting groups in sorting decisions: Methodology and use of a multi-criteria aggregation/disaggregation DSS. *Decision Support Systems*, 43(4):1464–1475.
- Deng, J. L. (1982). The control problems of grey systems. *Systems and Control Letters*, 1(5):288–294.
- Deng, J. L. (1989). Introduction to grey system theory. *Journal of Grey System*, 1(1):1–24.
- Dyer, J. S., Fishburn, P. C., Steuer, R. E., Wallenius, J., and Zionts, S. (1992). Multiple criteria decision making, multiattribute utility theory: the next ten years. *Management Science*, 38(5):645–654.
- Ekel, P. Y., Martini, J., and Palhares, R. M. (2008). Multicriteria analysis in decision making under information uncertainty. *Applied Mathematics and Computation*, 200(2):501–516.
- Emelko, M. B., Silins, U., Bladon, K. D., and Stone, M. (2011). Implications of land disturbance on drinking water treatability in a changing climate: Demonstrating the need for "source water supply and protection" strategies. *Water Research*, 45(2):461–472.
- Fang, L., Hipel, K. W., and Kilgour, D. M. (1993). *Interactive Decision Making: The Graph Model for Conflict Resolution*. Wiley, New York.
- Fang, L., Hipel, K. W., Kilgour, D. M., and Peng, X. (2003a). A decision support system for interactive decision making-part I: model formulation. *IEEE Transactions on Systems, Man, and Cybernetics, Part C: Applications and Reviews*, 33(1):42–55.

- Fang, L., Hipel, K. W., Kilgour, D. M., and Peng, X. (2003b). A decision support system for interactive decision making-part II: analysis and output interpretation. *IEEE Transactions on Systems, Man, and Cybernetics, Part C: Applications and Reviews*, 33(1):56–66.
- Ferreya, C. (2012). Practicality, positionality, and emancipation: reflections on participatory action research with a watershed partnership. *Systemic Practice and Action Research*, 19(6):577–598.
- Flores-Alsina, X., Rodriguez-Roda, I., Sin, G., and Gernaey, K. V. (2008). Multi-criteria evaluation of wastewater treatment plant control strategies under uncertainty. *Water Research*, 42(17):4485–4497.
- Fraser, N. M. and Hipel, K. W. (1984). *Conflict Analysis: Models and Resolutions*. North Holland, New York.
- French Jr, J. R. (1956). A formal theory of social power. *Psychological Review*, 63(3):181.
- Fürnkranz, J. and Hüllermeier, E. (2011). Preference learning and ranking by pairwise comparison. In *Preference Learning*, pages 65–82. Springer, Berlin and Heidelberg.
- Goumas, M. and Lygerou, V. (2000). An extension of the PROMETHEE method for decision making in fuzzy environment: Ranking of alternative energy exploitation projects. *European Journal of Operational Research*, 123(3):606–613.
- Government of Alberta (2008). Alberta’s oil sands: Opportunity, balance. Technical report. Available: http://www.environment.alberta.ca/documents/oil_sands_opportunity_balance.pdf.
- Grabisch, M., Labreuche, C., and Vansnick, J.-C. (2003). On the extension of pseudo-boolean functions for the aggregation of interacting criteria. *European Journal of Operational Research*, 148(1):28–47.
- Greco, S. (2004). *Multiple Criteria Decision Analysis: State of the Art Surveys*, volume 78. Springer, Boston.
- Greco, S., Matarazzo, B., and Slowinski, R. (1999). The use of rough sets and fuzzy sets in MCDM. In *Multicriteria Decision Making*, pages 397–455. Springer.
- Greco, S., Matarazzo, B., and Slowinski, R. (2001). Rough sets theory for multicriteria decision analysis. *European Journal of Operational Research*, 129(1):1–47.

- Guitouni, A. and Martel, J. M. (1998). Tentative guidelines to help choosing an appropriate MCDA method. *European Journal of Operational Research*, 109(2):501–521.
- Halouani, N., Chabchoub, H., and Martel, J.-M. (2009). Promethee-md-2t method for project selection. *European Journal of Operational Research*, 195(3):841–849.
- Hamouda, L., Kilgour, D. M., and Hipel, K. W. (2004). Strength of preference in the graph model for conflict resolution. *Group Decision and Negotiation*, 13(5):449–462.
- Han, X., Nguyen, T. D. L., and Xu, H. (2013). Conflict analysis based on the graph model for conflict resolution and grey matrix. *Grey Systems: Theory and Application*, 3(1):95–106.
- Hermans, C. M. and Erickson, J. D. (2007). *Multicriteria decision analysis: Overview and implications for environmental decision making*, chapter 12, pages 213–228. Emerald Group Publishing Limited.
- Herrera, F., Herrera-Viedma, E., and Martínez, L. (2000). A fusion approach for managing multi-granularity linguistic term sets in decision making. *Fuzzy Sets and Systems*, 114(1):43–58.
- Hipel, K. W. (1992). Multiple objective decision making in water resources. *Journal of the American Water Resources Association*, 28(1):3–12.
- Hipel, K. W. (2002). Conflict resolution: Theme overview paper in conflict resolution. *Encyclopedia of Life Support Systems (EOLSS)*. Oxford, UK: EOLSS Publishers, 2:50–52.
- Hipel, K. W. (2009a). *Conflict Resolution - Volume 1*. Eolss Publisher, Oxford, UK.
- Hipel, K. W. (2009b). *Conflict Resolution - Volume 2*. Eolss Publisher, Oxford, UK.
- Hipel, K. W. and Fang, L. (2005). *Multiple participant decision making in societal and technological systems*, chapter 1, pages 3–31. Elsevier Science.
- Hipel, K. W., Kilgour, D. M., and Bashar, M. A. (2011). Fuzzy preferences in multiple participant decision making. *Scientia Iranica*, 18(3):627–638.
- Hipel, K. W., Kilgour, D. M., Fang, L., and Peng, X. J. (1997). The decision support system GMCR in environmental conflict management. *Applied Mathematics and Computation*, 83(2):117–152.

- Hipel, K. W., Kilgour, D. M., Rajabi, S., and Chen, Y. (2009). Chapter 27 - operations research and refinement of courses of action. In Sage, A. P. and Rouse, W. B., editors, *Handbook of Systems Engineering and Management, Second Edition*, pages 1171–1222. Wiley, New York.
- Hipel, K. W. and Obeidi, A. (2005). Trade versus the environment: Strategic settlement from a systems engineering perspective. *Systems Engineering*, 8(3):211–233.
- Hipel, K. W., Radford, K. J., and Fang, L. (1993). Multiple participant multiple criteria decision making. *IEEE Transactions on Systems, Man and Cybernetics*, 23(4):1184–1189.
- Hipel, K. W. and Walker, S. B. (2011). Conflict analysis in environmental management. *Environmetrics*, 22(3):279–293.
- Hites, R., De Smet, Y., Risse, N., Salazar-Neumann, M., and Vincke, P. (2006). About the applicability of MCDA to some robustness problems. *European Journal of Operational Research*, 174(1):322–332.
- Howard, N. (1971). *Paradoxes of Rationality: Theory of Metagames and Political Behavior*. MIT Press, Cambridge, Mass.
- Humphries, M. (2008). North American oil sands: history of development, prospects for the future. Technical report, Congressional Research Service. Available: <http://fas.org/sgp/crs/misc/RL34258.pdf>.
- Hyde, K., Maier, H. R., and Colby, C. (2003). Incorporating uncertainty in the promethee mcda method. *Journal of Multi-Criteria Decision Analysis*, 12(4-5):245–259.
- Hyde, K. M. (2006). *Uncertainty Analysis Methods for Multi-Criteria Decision Analysis*. PhD thesis, The University of Adelaide.
- Hyde, K. M., Maier, H. R., and Colby, C. B. (2005). A distance-based uncertainty analysis approach to multi-criteria decision analysis for water resource decision making. *Journal of Environmental Management*, 77(4):278–290.
- Ian N. Durbach, T. J. S. (2012). Modeling uncertainty in multi-criteria decision analysis. *European Journal of Operational Research*, 223(1):1–14.
- IFP Energies Nouvelles (2011). Water in fuel production - oil production and refining. Technical report. Available: <http://www.ifpenergiesnouvelles>.

com/content/download/70601/1513892/version/2/file/Panorama2011_11-VA_Eau-Production-Carburants.pdf.

- Janis, I. L. and Mann, L. (1977). *Decision making: A psychological analysis of conflict, choice, and commitment*. New York: Free Press.
- Jiang, Y.-P., Fan, Z.-P., and Ma, J. (2008). A method for group decision making with multi-granularity linguistic assessment information. *Information Sciences*, 178(4):1098–1109.
- Kangas, J. and Kangas, A. (2005). Multiple criteria decision support in forest management—the approach, methods applied, and experiences gained. *Forest Ecology and Management*, 207(12):133–143.
- Kassab, M., Hipel, K. W., and Hegazy, T. (2006). Conflict resolution in construction disputes using the graph model. *Journal of Construction Engineering and Management*, 132(10):1043–1052.
- Keefer, D. L., Kirkwood, C. W., and Corner, J. L. (2004). Perspective on decision analysis applications, 1990–2001. *Decision analysis*, 1(1):4–22.
- Keeney, R. L. (1976). A group preference axiomatization with cardinal utility. *Management Science*, 23(2):140–145.
- Keeney, R. L. and Raiffa, H. (1976). *Decisions with Multiple Consequences: Preferences and Value Tradeoffs*. Wiley, New York.
- Keeney, R. L. and Raiffa, H. (1993). *Decisions with Multiple Objectives: Preferences and Value Trade-offs*. Cambridge University Press, Cambridge.
- Kilgour, D. M. and Eden, C. (2010). *Handbook of Group Decision and Negotiation*. Springer, Dordrecht.
- Kilgour, D. M. and Hipel, K. W. (2005). The graph model for conflict resolution: past, present, and future. *Group Decision and Negotiation*, 14(6):441–460.
- Kilgour, D. M., Hipel, K. W., and Fang, L. (1987). The graph model for conflicts. *Automatica*, 23(1):41–55.
- Klein, G. (2008). Naturalistic decision making. *Human Factors: The Journal of the Human Factors and Ergonomics Society*, 50(3):456–460.

- Kuang, H., Bashar, M. A., Hipel, K. W., and Kilgour, D. M. (2014a). Grey-based preference in a graph model for conflict resolution with multiple decision makers. Unpublished manuscript, Department of Systems Design Engineering, University of Waterloo, Waterloo, Ontario, Canada.
- Kuang, H., Bashar, M. A., Kilgour, D. M., and Hipel, K. W. (2014b). Strategic analysis of a brownfield revitalization conflict using the grey-based graph model for conflict resolution. Unpublished manuscript, Department of Systems Design Engineering, University of Waterloo, Waterloo, Ontario, Canada.
- Kuang, H., Hipel, K. W., and Kilgour, D. M. (2012). Evaluation of source water protection strategies in waterloo region based on grey systems theory and promethee ii. In *2012 IEEE International Conference on Systems, Man, and Cybernetics*, pages 2775–2779, Seoul, Korea.
- Kuang, H., Hipel, K. W., and Kilgour, D. M. (2014c). Conflict analysis on water use and oil sands development in the athabasca river. In *Proceedings of the 2014 IEEE International Conference on Systems, Man, and Cybernetics*, pages 2948-2952, San Diego, USA.
- Kuang, H., Hipel, K. W., Kilgour, D. M., and Bashar, M. A. (2013). A case study of grey-based preference in a graph model for conflict resolution with two decision makers. In *2013 IEEE International Conference on Systems, Man, and Cybernetics*, pages 2037–2041, Manchester, United Kingdom.
- Kuang, H., Kilgour, D. M., and Hipel, K. W. (2014d). Grey-based PROMETHEE II with application to evaluation of source water protection strategies. *Information Sciences*, <http://dx.doi.org/10.1016/j.ins.2014.09.035>.
- Larrick, R. P., Morgan, J. N., and Nisbett, R. E. (1990). Teaching the use of cost-benefit reasoning in everyday life. *Psychological Science*, 1(6):362–370.
- Le Teno, J. F. and Mareschal, B. (1998). An interval version of promethee for the comparison of building products' design with ill-defined data on environmental quality. *European Journal of Operational Research*, 109(2):522–529.
- Leyva-Lopez, J. C. and Fernandez-Gonzalez, E. (2003). A new method for group decision support based on ELECTRE III methodology. *European Journal of Operational Research*, 148(1):14–27.
- Li, G.-D., Yamaguchi, D., and Nagai, M. (2007). A grey-based decision-making approach to the supplier selection problem. *Mathematical and Computer Modelling*, 46(3-4):573–581.

- Li, K. W., Hipel, K. W., Kilgour, D. M., and Fang, L. (2004). Preference uncertainty in the graph model for conflict resolution. *IEEE Transactions on Systems, Man and Cybernetics, Part A: Systems and Humans*, 34(4):507–520.
- Li, W.-x. and Li, B.-y. (2010). An extension of the promethee ii method based on generalized fuzzy numbers. *Expert Systems with Applications*, 37(7):5314–5319.
- Lin, Y. and Liu, S. (2004). A historical introduction to grey systems theory. In *Systems, Man and Cybernetics, 2004 IEEE International Conference on*, volume 3, pages 2403–2408. IEEE.
- Liou, J. J., Hsu, C.-C., Yeh, W.-C., and Lin, R.-H. (2011). Using a modified grey relation method for improving airline service quality. *Tourism Management*, 32(6):1381–1388.
- Liu, S. and Fang, Z.-G. (2006). Study on algorithm of grey numbers and grey algebraic system. In *2006 IEEE International Conference on Systems, Man and Cybernetics*, volume 3, pages 2272–2276. IEEE.
- Liu, S. and Forrest, J. (2007). The current developing status on grey system theory. *The Journal of Grey System*, 19(2):111–123.
- Liu, S. and Forrest, J. Y. L. (2010). *Grey Systems: Theory and Applications*, volume 68. Springer Verlag.
- Liu, S. and Lin, Y. (2010). *Advances in Grey Systems Research*. Springer, verlag berlin heidelberg.
- Maas, T. (2009). Brief to house of commons standing committee on environment and sustainable development hearings on oil sands and water issues. Technical report, World Wildlife Fund. Available: http://awsassets.wwf.ca/downloads/wwf_canada_brief_to_envi_hearings_on_oil_sands_and_water.pdf
- Machant, T. (1996). Valued relations aggregation with the Borda method. *Journal of Multi-Criteria Decision Analysis*, 5(2):127–132.
- Marler, R. T. and Arora, J. S. (2004). Survey of multi-objective optimization methods for engineering. *Structural and Multidisciplinary Optimization*, 26(6):369–395.
- Matsatsinis, N. F. and Samaras, A. P. (2001). MCDA and preference disaggregation in group decision support systems. *European Journal of Operational Research*, 130(2):414–429.

- Mendoza, G. and Martins, H. (2006). Multi-criteria decision analysis in natural resource management: a critical review of methods and new modelling paradigms. *Forest Ecology and Management*, 230(1):1–22.
- Mingers, J. and Rosenhead, J. (2004). Problem structuring methods in action. *European Journal of Operational Research*, 152(3):530–554.
- Nash, J. F. (1950). Equilibrium points in n-person games. *Proceedings of the national academy of sciences*, 36(1):48–49.
- Ng, D. K. (1994). Grey system and grey relational model. *ACM SIGICE Bulletin*, 20(2):2–9.
- Özcan, T., Çelebi, N., and Esnaf, Ş. (2011). Comparative analysis of multi-criteria decision making methodologies and implementation of a warehouse location selection problem. *Expert Systems with Applications*, 38(8):9773–9779.
- Ozernoy, V. M. (1992). Choosing the best multiple criteria decision-making method. *Information System and Operational Research*, 30(2):159–170.
- Patrick, R. J. (2011). Uneven access to safe drinking water for first nations in Canada: Connecting health and place through source water protection. *Health and Place*, 17(number):386–389.
- Pedrycz, W., Ekel, P., and Parreiras, R. (2011). *Fuzzy multicriteria decision-making: models, methods and applications*. Wiley, Chichester, United Kingdom.
- Pratt, J. W., Raiffa, H., and Schlaifer, R. (1995). *Introduction to statistical decision theory*. MIT press.
- Qin, X., Huang, G., Chen, B., and Zhang, B. (2009). An interval-parameter waste-load-allocation model for river water quality management under uncertainty. *Environmental Management*, 43(6):999–1012.
- Radford, K. J. (1988). *Strategic and tactical decisions*. Springer-Verlag, New York.
- Rajabi, S., Hipel, K. W., and Kilgour, D. M. (2001). Multiple criteria screening of large water policy subset selection problem. *Journal of the American Water Resources Association*, 37(3):533–546.

- Region of Waterloo (2000). Regional municipality of Waterloo council report. Technical report, Kitchener, Ontario, Canada. Available: http://www.regionofwaterloo.ca/en/aboutTheEnvironment/resources/RMOW%20long%20term%20water%20strategy%20council%20report%20e-00-027_1.pdf
- Region of Waterloo (2008). Water resources protection master plan. Technical report, Kitchener, Ontario, Canada. Available: <http://www.regionofwaterloo.ca/en/aboutTheEnvironment/resources/WRPMP.pdf>.
- Regional Municipality of Waterloo and Water Services Division (1994). Regional municipality of Waterloo long term water strategy evaluation workbook phase 1 report by associated engineering. Technical report. Available: http://row.minisisinc.com/page/detail/PUB_DESCRIPTION?SISN=6539.
- Renner, R. (2010). Scientists to review water monitoring data from oil sands. Technical report, Alberta Government Caucus, Edmonton, Alberta. Available: <http://www.myclients.ca/mycampaign6/display.php?List=1645&N=14533>.
- Roy, B. (1991). The outranking approach and the foundations of elective methods. *Theory and Decision*, 31(1):49–73.
- Saaty, T. L. (1994). *Fundamentals of Decision Making and Priority Theory with the Analytic Hierarchy Process*, volume 1. RWS Publications Pittsburgh, Pittsburgh, PA.
- Scheier, M. F. and Carver, C. S. (1985). Optimism, coping, and health: assessment and implications of generalized outcome expectancies. *Health psychology*, 4(3):219.
- Steward, T. (1992). A critical survey on the status of multiple criteria decision making theory and practice. *Omega*, 20(5-6):569–586.
- Tacnet, J. M., Dezert, J., and Batton-Hubert, M. (2011). AHP and uncertainty theories for decision making using the ER-MCDA methodology. In *International Symposium on Analytic Hierarchy/Network Process, Sorrento, Italy*.
- Tamiz, M., Jones, D., and Romero, C. (1998). Goal programming for decision making: An overview of the current state-of-the-art. *European Journal of Operational Research*, 111(3):569–581.
- Tseng, M.-L. (2010). Using linguistic preferences and grey relational analysis to evaluate the environmental knowledge management capacity. *Expert Systems with Applications*, 37(1):70–81.

- Tversky, A. and Kahneman, D. (1986). Rational choice and the framing of decisions. *Journal of business*, pages S251–S278.
- Tylock, S. M., Seager, T. P., Snell, J., Bennettc, E. R., and Sweet, D. (2012). Energy management under policy and technology uncertainty. *Energy Policy*, 47(0):156–163.
- Vincke, P. (1992). *Multicriteria Decision-aid*. Wiley, New York.
- Wallenius, J., Dyer, J. S., Fishburn, P. C., Steuer, R. E., Zionts, S., and Deb, K. (2008). Multiple criteria decision making, multiattribute utility theory: Recent accomplishments and what lies ahead. *Management Science*, 54(7):1336–1349.
- Wei, G. (2011). Grey relational analysis method for 2-tuple linguistic multiple attribute group decision making with incomplete weight information. *Expert Systems with Applications*, 38(9):4824–4828.
- Woynillowicz, D. and Severson-Baker, C. (2006). Down to the last drop: The athabasca river and oilsands. Technical report, Pembina Institute. Available: <http://www.pembina.org/pub/211>.
- Xu, Z.-S. and Da, Q.-L. (2002). The uncertain OWA operator. *International Journal of Intelligent Systems*, 17(6):569–575.
- Yager, R. R. (1995). An approach to ordinal decision making. *International Journal of Approximate Reasoning*, 12(3-4):237–261.
- Yang, Y. and John, R. (2012). Grey sets and greyness. *Information Science*, 185(1):249–264.
- Yang, Y., John, R., and Chiclana, F. (2004). Grey sets, fuzzy sets and rough sets. In *Proceedings of the 5th International Conference on Recent Advances in Soft Computing, RASC 2004, Nottingham, UK, 16-18 December 2004*, pages 348–353.
- Yang, Y. and Liu, S. (2011). Reliability of operations of grey numbers using kernels. *Grey Systems: Theory and Application*, 1(1):57–71.
- Yiyo Kuo, Taho Yang, G.-W. H. (2008). The use of grey relational analysis in solving multiple attribute decision-making problems. *Computers and Industrial Engineering*, 55(1):80–93.

- Zarghami, M., Szidarovszky, F., Zarghami, M., and Szidarovszky, F. (2011). MCDA Problems Under Uncertainty. In *Multicriteria Analysis*, pages 113–147. Springer Berlin Heidelberg.
- Zhai, L.-Y., Khoo, L.-P., and Zhong, Z.-W. (2009). Design concept evaluation in product development using rough sets and grey relation analysis. *Expert Systems with Applications*, 36(3):7072–7079.
- Zhang, J., Wu, D., and Olson, D. (2005). The method of grey related analysis to multiple attribute decision making problems with interval numbers. *Mathematical and Computer Modelling*, 42(9):991–998.
- Zhang, S.-f., Liu, S.-y., and Zhai, R.-h. (2011). An extended GRA method for MCDM with interval-valued triangular fuzzy assessments and unknown weights. *Computers & Industrial Engineering*, 61(4):1336–1341.
- Zitzler, E. and Thiele, L. (1999). Multiobjective evolutionary algorithms: A comparative case study and the strength pareto approach. *IEEE Transactions on Evolutionary Computation*, 3(4):257–271.